

Marks' Calculations for Machine Design

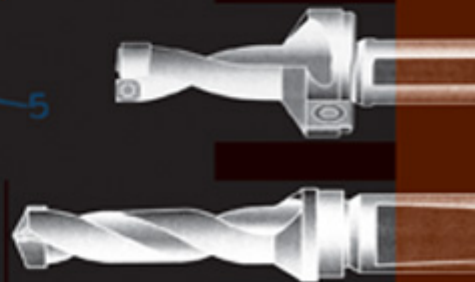

- Foundational Loading
- Thermal Stress and Strain
- Static Design and Column Buckling
- Fatigue and Dynamic Loading



Thomas H. Brown, Jr.

**MARKS'
CALCULATIONS FOR
MACHINE DESIGN**





This page intentionally left blank.

MARKS' CALCULATIONS FOR MACHINE DESIGN

Thomas H. Brown, Jr., Ph.D., P.E.

Faculty Associate

Institute for Transportation Research and Education

NC State University

Raleigh, North Carolina

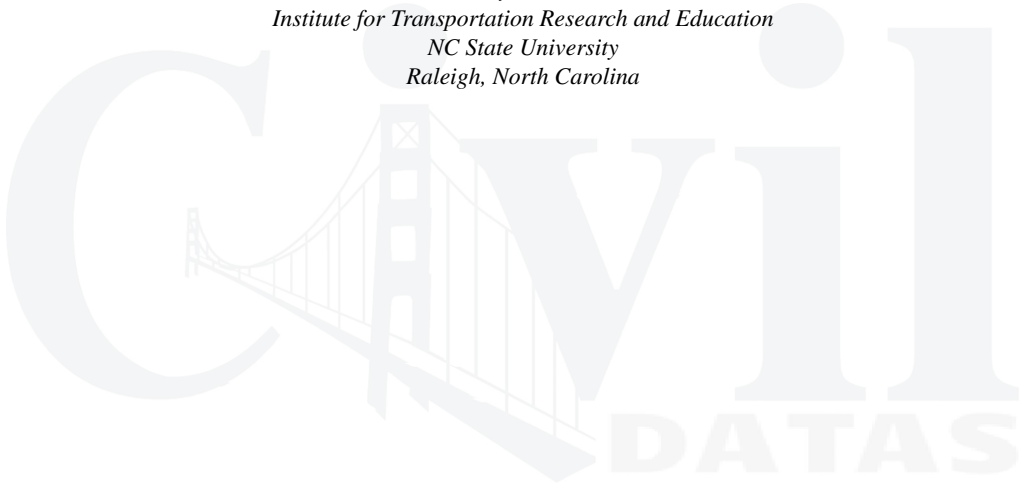

McGRAW-HILL

**New York Chicago San Francisco Lisbon London Madrid
Mexico City Milan New Delhi San Juan Seoul
Singapore Sydney Toronto**

Copyright © 2005 by The McGraw-Hill Companies, Inc. All rights reserved. Manufactured in the United States of America. Except as permitted under the United States Copyright Act of 1976, no part of this publication may be reproduced or distributed in any form or by any means, or stored in a database or retrieval system, without the prior written permission of the publisher.

0-07-146691-6

The material in this eBook also appears in the print version of this title: 0-07-143689-8.

All trademarks are trademarks of their respective owners. Rather than put a trademark symbol after every occurrence of a trademarked name, we use names in an editorial fashion only, and to the benefit of the trademark owner, with no intention of infringement of the trademark. Where such designations appear in this book, they have been printed with initial caps. McGraw-Hill eBooks are available at special quantity discounts to use as premiums and sales promotions, or for use in corporate training programs. For more information, please contact George Hoare, Special Sales, at george_hoare@mcgraw-hill.com or (212) 904-4069.

TERMS OF USE

This is a copyrighted work and The McGraw-Hill Companies, Inc. ("McGraw-Hill") and its licensors reserve all rights in and to the work. Use of this work is subject to these terms. Except as permitted under the Copyright Act of 1976 and the right to store and retrieve one copy of the work, you may not decompile, disassemble, reverse engineer, reproduce, modify, create derivative works based upon, transmit, distribute, disseminate, sell, publish or sublicense the work or any part of it without McGraw-Hill's prior consent. You may use the work for your own noncommercial and personal use; any other use of the work is strictly prohibited. Your right to use the work may be terminated if you fail to comply with these terms. THE WORK IS PROVIDED "AS IS." MCGRAW-HILL AND ITS LICENSORS MAKE NO GUARANTEES OR WARRANTIES AS TO THE ACCURACY, ADEQUACY OR COMPLETENESS OF OR RESULTS TO BE OBTAINED FROM USING THE WORK, INCLUDING ANY INFORMATION THAT CAN BE ACCESSED THROUGH THE WORK VIA HYPERLINK OR OTHERWISE, AND EXPRESSLY DISCLAIM ANY WARRANTY, EXPRESS OR IMPLIED, INCLUDING BUT NOT LIMITED TO IMPLIED WARRANTIES OF MERCHANTABILITY OR FITNESS FOR A PARTICULAR PURPOSE. McGraw-Hill and its licensors do not warrant or guarantee that the functions contained in the work will meet your requirements or that its operation will be uninterrupted or error free. Neither McGraw-Hill nor its licensors shall be liable to you or anyone else for any inaccuracy, error or omission, regardless of cause, in the work or for any damages resulting therefrom. McGraw-Hill has no responsibility for the content of any information accessed through the work. Under no circumstances shall McGraw-Hill and/or its licensors be liable for any indirect, incidental, special, punitive, consequential or similar damages that result from the use of or inability to use the work, even if any of them has been advised of the possibility of such damages. This limitation of liability shall apply to any claim or cause whatsoever whether such claim or cause arises in contract, tort or otherwise.

DOI: 10.1036/0071466916



Professional



Want to learn more?

We hope you enjoy this McGraw-Hill eBook! If you'd like more information about this book, its author, or related books and websites, please [click here](#).

To Miriam and Paulie





This page intentionally left blank.

CONTENTS

Foreword	xi
Preface	xiii
Acknowledgments	xv

Part 1 Strength of Machines

Chapter 1. Fundamental Loadings **3**

- 1.1. Introduction / 3
- 1.2. Axial Loading / 4
- 1.3. Direct Shear / 11
- 1.4. Torsion / 16
- 1.5. Bending / 24

Chapter 2. Beams: Reactions, Shear Force and Bending Moment Distributions, and Deflections **33**

- 2.1. Introduction / 33
- 2.2. Simply-Supported Beams / 35
 - 2.2.1. Concentrated Force at Midpoint / 36
 - 2.2.2. Concentrated Force at Intermediate Point / 41
 - 2.2.3. Concentrated Couple / 48
 - 2.2.4. Uniform Load / 55
 - 2.2.5. Triangular Load / 60
 - 2.2.6. Twin Concentrated Forces / 67
 - 2.2.7. Single Overhang: Concentrated Force at Free End / 73
 - 2.2.8. Single Overhang: Uniform Load / 79
 - 2.2.9. Double Overhang: Concentrated Forces at Free Ends / 86
 - 2.2.10. Double Overhang: Uniform Load / 92
- 2.3. Cantilevered Beams / 97
 - 2.3.1. Concentrated Force at Free End / 98
 - 2.3.2. Concentrated Force at Intermediate Point / 104
 - 2.3.3. Concentrated Couple / 110
 - 2.3.4. Uniform Load / 115
 - 2.3.5. Triangular Load / 120

Chapter 3. Advanced Loadings **127**

- 3.1. Introduction / 127
- 3.2. Pressure Loadings / 127

- 3.2.1. Thin-Walled Vessels / 128
- 3.2.2. Thick-Walled Cylinders / 130
- 3.2.3. Press or Shrink Fits / 134
- 3.3. Contact Loading / 139
 - 3.3.1. Spheres in Contact / 139
 - 3.3.2. Cylinders in Contact / 143
- 3.4. Rotational Loading / 147

Chapter 4. Combined Loadings

153

- 4.1. Introduction / 153
- 4.2. Axial and Torsion / 156
- 4.3. Axial and Bending / 159
- 4.4. Axial and Thermal / 164
- 4.5. Torsion and Bending / 167
- 4.6. Axial and Pressure / 172
- 4.7. Torsion and Pressure / 175
- 4.8. Bending and Pressure / 184

Chapter 5. Principal Stresses and Mohr's Circle

189

- 5.1. Introduction / 189
- 5.2. Principal Stresses / 190
- 5.3. Mohr's Circle / 205

Chapter 6. Static Design and Column Buckling

233

- 6.1. Static Design / 233
 - 6.1.1. Static Design for Ductile Materials / 234
 - 6.1.2. Static Design for Brittle Materials / 246
 - 6.1.3. Stress-Concentration Factors / 258
- 6.2. Column Buckling / 260
 - 6.2.1. Euler Formula / 261
 - 6.2.2. Parabolic Formula / 263
 - 6.2.3. Secant Formula / 266
 - 6.2.4. Short Columns / 270

Chapter 7. Fatigue and Dynamic Design

273

- 7.1. Introduction / 273
- 7.2. Reversed Loading / 274
- 7.3. Marin Equation / 279
- 7.4. Fluctuating Loading / 285
- 7.5. Combined Loading / 311

Part 2 Application to Machines

Chapter 8. Machine Assembly

321

- 8.1. Introduction / 321
- 8.2. Bolted Connections / 321

- 8.2.1. The Fastener Assembly / 321
- 8.2.2. The Members / 326
- 8.2.3. Bolt Strength and Preload / 331
- 8.2.4. The External Load / 332
- 8.2.5. Static Loading / 335
- 8.2.6. Fatigue Loading / 337
- 8.3. Welded Connections / 348
 - 8.3.1. Axial and Transverse Loading / 348
 - 8.3.2. Torsional Loading / 352
 - 8.3.3. Bending Loading / 356
 - 8.3.4. Fillet Welds Treated as Lines / 360
 - 8.3.5. Fatigue Loading / 365

Chapter 9. Machine Energy

367

- 9.1. Introduction / 367
- 9.2. Helical Springs / 367
 - 9.2.1. Loads, Stresses, and Deflection / 367
 - 9.2.2. Spring Rate / 371
 - 9.2.3. Work and Energy / 375
 - 9.2.4. Series and Parallel Arrangements / 377
 - 9.2.5. Extension Springs / 379
 - 9.2.6. Compression Springs / 380
 - 9.2.7. Critical Frequency / 383
 - 9.2.8. Fatigue Loading / 385
- 9.3. Flywheels / 388
 - 9.3.1. Inertial Energy of a Flywheel / 388
 - 9.3.2. Internal Combustion Engine Flywheels / 392
 - 9.3.3. Punch Press Flywheels / 395
 - 9.3.4. Composite Flywheels / 401

Chapter 10. Machine Motion

409

- 10.1. Introduction / 409
- 10.2. Linkages / 410
 - 10.2.1. Classic Designs / 410
 - 10.2.2. Relative Motion / 412
 - 10.2.3. Cyclic Motion / 421
- 10.3. Gear Trains / 424
 - 10.3.1. Spur Gears / 425
 - 10.3.2. Planetary Gears / 428
- 10.4. Wheels and Pulleys / 431
 - 10.4.1. Rolling Wheels / 432
 - 10.4.2. Pulley Systems / 435

Bibliography 439

Index 441



This page intentionally left blank.

FOREWORD

Once the design and components of a machine have been selected there is an important engineering analysis process the machine designer should perform to verify the integrity of the design. That is what this book is about.

The purpose of *Marks' Calculations for Machine Design* is to uncover the mystery behind the principles, and particularly the formulas, used in machine design. All too often a formula found in the best of references is presented without the necessary background for the designer to understand how it was developed. This can be frustrating because of a lack of clarity as to what assumptions have been made in the formula's development. Typically, few if any examples are presented to illustrate the application of the formula with appropriate units. While these references are invaluable this companion book presents the application.

In *Marks' Calculations for Machine Design* the necessary background for every machine design formula presented is provided. The mathematical details of the development of a particular design formula have been provided only if the development enlightens and illuminates the fundamental principles for the machine designer. If the details of the development are only a mathematical exercise, they have been omitted. For example, in Chapter 9 the steps involved in the development of the design formulas for helical springs are presented in great detail since valuable insight is obtained about the true nature of the loading on such springs and because algebra is the only mathematics needed in the steps. On the other hand, in Chapter 3 the formulas for the tangential and radial stresses in a high-speed rotating thin disk are presented without their mathematical development since they derive from the simultaneous integration of two differential equations and the application of appropriate boundary conditions. No formula is presented unless it is used in one or more of the numerous examples provided or used in the development of another design formula.

Why has this approach been taken? Because a formula that remains a mystery is a formula unused, and a formula unused is an opportunity missed—forever.

It is hoped that *Marks' Calculations for Machine Design* will provide a level of comfort and confidence in the principles and formulas of machine design that ultimately produces a successful and safe design, and a proud designer.

THOMAS H. BROWN, JR., PH.D., P.E.



This page intentionally left blank.

PREFACE

As the title of this book implies, *Marks' Calculations for Machine Design* was written to be a companion to *Marks' Standard Handbook for Mechanical Engineers*, providing detailed calculations to the important problems in machine design. For each of the over 175 examples presented, complete solutions are provided, including appropriate figures and diagrams, all algebra and arithmetic steps, and using both the U.S. Customary and SI/Metric systems of units. It is hoped that *Marks' Calculations for Machine Design* will provide an enthusiastic beginning for those just starting out in mechanical engineering, as well as provide a comprehensive resource for those currently involved in machine design projects.

Marks' Calculations for Machine Design is divided into two main parts: Part 1, Strength of Machines, and Part 2, Application to Machines. Part 1 contains seven chapters on the foundational principles and equations of machine design, from basic to advanced, while Part 2 contains three chapters on the most common machine elements based on these principles and equations.

Beginning Part 1, Chapter 1, *Fundamental Loadings*, contains the four foundational loadings: axial, direct shear, torsion, and bending. Formulas for stress and strain, both normal and shear, along with appropriate examples are presented for each of these loadings. Thermal stress and strain are also covered. Stress-strain diagrams are provided for both ductile and brittle materials, and the three engineering properties, (E), (G), and (ν), are discussed.

Chapter 2, *Beams*, provides the support reactions, shear and bending moment diagrams, and deflection equations for fifteen different beam configurations. There are ten simply-supported beam configurations, from end supported, single overhanging, and double overhanging. There are five cantilevered beam configurations. Loadings include concentrated forces and couples, as well as uniform and triangular shaped distributed loadings. Almost 45% of the total number of examples and over 30% of the illustrations are in this single chapter. Nowhere is there a more comprehensive presentation of solved beam examples.

Chapter 3, *Advanced Loadings*, covers three such loadings: pressure loadings, to include thin- and thick-walled vessels and press/shrink fits; contact loading, to include spherical and cylindrical geometries; and high-speed rotational loading.

Chapter 4, *Combined Loadings*, brings the basic and advanced loadings covered in Chapters 1, 2, and 3 together in a discussion of how loadings can be combined. Seven different combinations are presented, along with the concept of a plane stress element.

Chapter 5, *Principal Stresses and Mohr's Circle*, takes the plane stress elements developed in Chapter 4 and presents the transformation equations for determining the principal stresses, both normal and shear, and the associated rotated stress elements. Mohr's circle, the graphical representation of these transformation equations, is also presented. The Mohr's circle examples provided include multiple diagrams in the solution process, a half dozen on average, so that the reader does not get lost, as typically happens with the more complex single solution diagrams of most other references.

Chapter 6, *Static Design and Column Buckling*, includes two major topics: design under static conditions and the buckling of columns. The section on static design covers both ductile and brittle materials, and a discussion on stress concentration factors for brittle materials with notch sensitivity. In the discussion on ductile materials, the

maximum-normal-stress theory, the maximum-shear-stress theory, and the distortion-energy theory are presented with examples. Similarly, for brittle materials, the maximum-normal-stress theory, the Coulomb-Mohr theory, and the modified Coulomb-Mohr theory are presented with examples. The discussion on stress concentration factors provides how to use the stress-concentration factors found in *Marks' Standard Handbook for Mechanical Engineers* and other references. In the discussion on column buckling, the Euler formula is presented for long slender columns, the parabolic formula for intermediate length columns, the secant formula for eccentric loading, as well as a discussion on how to deal with short columns.

Chapter 7, *Fatigue and Dynamic Design*, contains information on how to design for dynamic conditions, or fatigue. Fatigue associated with reversed loading, fluctuating loading, and combined loading is discussed with numerous examples. The Marin equation is provided with examples on the influence of its many modifying factors that contribute to establishing an endurance limit, which in turn is used to decide whether a design is safe. Extensive use of the Goodman diagram as a graphical approach to determine the safety of a design is presented with appropriate examples.

Beginning Part 2, Chapter 8, *Machine Assembly*, discusses the two most common ways of joining machine elements: bolted connections and welded connections. For bolted connections, the design of the fastener, the members, calculation of the bolt preload in light of the bolt strength and the external load, static loading, and fatigue loading are presented with numerous examples. For welded connections, both butt and fillet welds, axial, transverse, torsional, and bending loading is discussed, along with the effects of dynamic loading, or fatigue, in shear.

Chapter 9, *Machine Energy*, considers two of the most common machine elements associated with the energy of a mechanical system: springs and flywheels. The extensive discussion on springs is limited to helical springs, however these are the most common type used. Additional spring types will be presented in future editions. In the discussion on flywheels, two system types are presented: internal combustion engines where torque is a function of angular position, and electric motor driven punch presses where torque is a function of angular velocity.

Chapter 10, *Machine Motion*, covers the typical machine elements that move: linkages, gears, wheels and pulleys. The section on linkages includes the three most famous designs: the four-bar linkage, the quick-return linkage, and the slider-crank linkage. Extensive calculations of velocity and acceleration for the slider-crank linkage are presented with examples. Gears, whether spur, helical, or herringbone, are usually assembled into gear trains, of which there are two general types: spur and planetary. Spur gear trains involve two or more fixed parallel axles. The relationship between the speeds of these gear trains, based on the number of gear teeth in contact, is presented with examples. Planetary gear trains, where one or more planet gears rotate about a single sun gear, are noted for their compactness. The relative speeds between the various elements of this type of design are presented.

While much has been presented in these ten chapters, some topics had to be left out to meet the schedule, not unlike the choices and tradeoffs that are part of the day-to-day practice of engineering. If there are topics the reader would like to see covered in the second edition, the author would very much like to know. Though much effort has been spent in trying to make this edition error free, there are inevitably still some that remain. Again, the author would appreciate knowing where these appear.

Good luck on your designs. It has been a pleasure uncovering the mystery of the principles and formulas in machine design that are so important to bringing about a safe and operationally sound design. It is hoped that the material in this book will inspire and give confidence to your designs. There is no greater reward to a machine designer than to know they have done their best, incorporating the best practices of their profession. And remember the first rule of machine design as told to me by my first supervisor, "when in doubt, make it stout!"

ACKNOWLEDGMENTS

My deepest appreciation and abiding love goes to my wife, Miriam, who is also my dearest and best friend. Her encouragement, help, suggestions, and patience over the many long hours it took to complete this book is a blessing from the Lord.

I am grateful for the love and understanding of my three children, Sianna, Hunter, and Elliott, who have been so very patient through the many weekends without their Dad, and who are a continual joy and source of immense pride.

To my Senior Editor Ken McCombs, whose confidence and support have guided me throughout this project, I gratefully give thanks. To Sam (Samik RoyChowdhury) and his wonderful and competent staff at International Typesetting and Composition (ITC) in Noida, India—it has been a pleasure and honor to work with you in dealing with the “bzillion” details to bring this book to reality.

And finally, thanks to Paulie (Paul Teutel, Jr.) of Orange County Choppers who embodies the true art of machine design. The unique motorcycles he and the staff at OCC bring to life, particularly the fabulous theme bikes, represents the joy and pride that mechanical design can provide.

THOMAS H. BROWN, JR., PH.D., P.E.



This page intentionally left blank.

P · A · R · T · 1

STRENGTH OF MACHINES





This page intentionally left blank.

CHAPTER 1

FUNDAMENTAL LOADINGS

1.1 INTRODUCTION

The fundamental loadings on machine elements are axial loading, direct shear loading, torsion, and bending. Each of these loadings produces stresses in the machine element, as well as deformations, meaning a change in shape. There are only two types of stresses: normal and shear. Axial loading produces a normal stress, direct shear and torsion produce shear stresses, and bending produces both a normal and a shear stress.

Figure 1.1 shows a straight prismatic bar loaded in tension by opposing forces (P) at each end. (A prismatic bar has a uniform cross section along its length.) These forces produce a tensile load along the axis of the bar, which is why it is called axial loading, resulting in a tensile normal stress in the bar. There is also a corresponding lengthening of the bar. If these forces were in the opposite direction, then the bar would be loaded in compression, producing a compressive normal stress and a shortening of the bar.

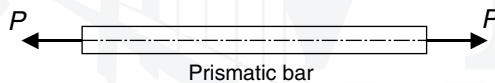

FIGURE 1.1 Axial loading.

Figure 1.2 shows a riveted joint, where a simple rivet holds two overlapping bars together. The shaft of the rivet at the interface of the bars is in direct shear, meaning that a shear stress is produced in the rivet. As the forces (P) increase, the joint will rotate until either the rivet *shears* off, or the material around the hole of either bar pulls out.

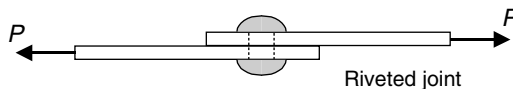

FIGURE 1.2 Direct shear loading.

Figure 1.3 shows a circular shaft acted upon by opposing torques (T), causing the shaft to be in torsion. This type of loading produces a shear stress in the shaft, thereby causing one end of the shaft to rotate about the axis of the shaft relative to the other end.

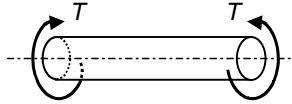

FIGURE 1.3 Torsion.

Figure 1.4 shows a simply supported beam with a concentrated force (F) located at its midpoint. This force produces both a bending moment distribution and a shear force distribution in the beam. At any location along the length (L) of the beam, the bending moment produces a normal stress, and the shear force produces a shear stress.

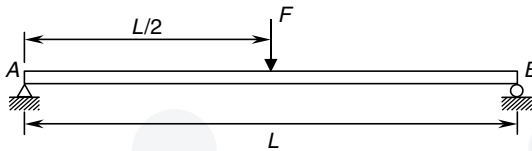

FIGURE 1.4 Bending.

The beam shown in Fig. 1.4 will deflect downward along its length; however, unlike axial loading, direct shear loading, and torsion that have a single equation associated with their deformation, there is not a single equation for the deformation or deflection of any beam under any loading. Each beam configuration and loading is different. A detailed discussion of 15 different beam configurations is presented in Chap. 2, complete with reactions, shear force and bending moment distributions, and deflection equations.

1.2 AXIAL LOADING

The prismatic bar shown in Fig. 1.5 is loaded in tension along its axis by the opposing forces (P) at each end. Again, a prismatic bar has a uniform cross section, and therefore a constant area (A) along its length.

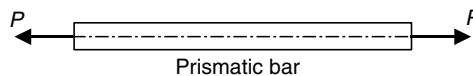

FIGURE 1.5 Axial loading.

Stress. These two forces produce a tensile load along the axis of the bar, resulting in a tensile normal stress (σ) given by Eq. (1.1).

$$\sigma = \frac{P}{A} \quad (1.1)$$

As stress is expressed by force over area, the unit is given in pound per square inch (psi) in the U.S. Customary System, and in newton per square meter, or pascal (Pa), in the metric system.

U.S. Customary	SI/Metric
<p>Example 1. Determine the normal stress in a square bar with side (a) loaded in tension with forces (P), where</p> $P = 12 \text{ kip} = 12,000 \text{ lb}$ $a = 2 \text{ in}$ <p>solution</p> <p><i>Step 1.</i> Calculate the cross-sectional area (A) of the bar.</p> $A = a^2 = (2 \text{ in})^2 = 4 \text{ in}^2$ <p><i>Step 2.</i> From Eq. (1.1), calculate the normal stress (σ) in the bar.</p> $\sigma = \frac{P}{A} = \frac{12,000 \text{ lb}}{4 \text{ in}^2}$ $= 3,000 \text{ lb/in}^2 = 3.0 \text{ kpsi}$ <p>Example 2. Calculate the minimum cross-sectional area (A_{\min}) needed for a bar axially loaded in tension by forces (P) so as not to exceed a maximum normal stress (σ_{\max}), where</p> $P = 10 \text{ kip} = 10,000 \text{ lb}$ $\sigma_{\max} = 36,000 \text{ psi}$ <p>solution</p> <p><i>Step 1.</i> Start with Eq. (1.1) where the normal stress (σ) is maximum and the area (A) is minimum to give</p> $\sigma_{\max} = \frac{P}{A_{\min}}$ <p><i>Step 2.</i> Solve for the minimum area (A_{\min}).</p> $A_{\min} = \frac{P}{\sigma_{\max}}$ <p><i>Step 3.</i> Substitute for the force (P) and the maximum normal stress.</p> $A_{\min} = \frac{10,000 \text{ lb}}{36,000 \text{ lb/in}^2} = 0.28 \text{ in}^2$	<p>Example 1. Determine the normal stress in a square bar with side (a) loaded in tension with forces (P), where</p> $P = 55 \text{ kN} = 55,000 \text{ N}$ $a = 5 \text{ cm} = 0.05 \text{ m}$ <p>solution</p> <p><i>Step 1.</i> Calculate the cross-sectional area A of the bar.</p> $A = a^2 = (0.05 \text{ m})^2 = 0.0025 \text{ m}^2$ <p><i>Step 2.</i> From Eq. (1.1), calculate the normal stress (σ) in the bar.</p> $\sigma = \frac{P}{A} = \frac{55,000 \text{ N}}{0.0025 \text{ m}^2}$ $= 22,000,000 \text{ N/m}^2 = 22 \text{ MPa}$ <p>Example 2. Calculate the minimum cross-sectional area (A_{\min}) needed for a bar axially loaded in tension by forces (P) so as not to exceed a maximum normal stress (σ_{\max}), where</p> $P = 45 \text{ kN} = 45,000 \text{ N}$ $\sigma_{\max} = 250 \text{ MPa}$ <p>solution</p> <p><i>Step 1.</i> Start with Eq. (1.1) where the normal stress (σ) is maximum and the area (A) is minimum to give</p> $\sigma_{\max} = \frac{P}{A_{\min}}$ <p><i>Step 2.</i> Solve for the minimum area (A_{\min}).</p> $A_{\min} = \frac{P}{\sigma_{\max}}$ <p><i>Step 3.</i> Substitute for the force (P) and the maximum normal stress.</p> $A_{\min} = \frac{45,000 \text{ N}}{250 \times 10^6 \text{ N/m}^2} = 0.00018 \text{ m}^2$

Strain. The axial loading shown in Fig. 1.6 also produces an axial strain (ϵ), given by Eq. (1.2).

$$\epsilon = \frac{\delta}{L} \quad (1.2)$$

where (δ) is change in length of the bar and (L) is length of the bar.

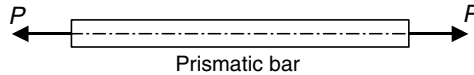

FIGURE 1.6 Axial loading.

Strain is a dimensionless quantity and does not have a unit if the change in length ϵ and the length (L) are in the same units. However, if the change in length (δ) is in inches or millimeters, and the length (L) is in feet or meters, then the strain (ϵ) will have a unit.

U.S. Customary	SI/Metric
<p>Example 3. Calculate the strain (ϵ) for a change in length (δ) and a length (L), where</p> <p>$\delta = 0.015$ in $L = 5$ ft</p> <p>solution <i>Step 1.</i> Calculate the strain (ϵ) from Eq. (1.2).</p> $\epsilon = \frac{\delta}{L} = \frac{0.015 \text{ in}}{5 \text{ ft}}$ $= 0.003 \text{ in/ft} \times 1 \text{ ft}/12 \text{ in}$ $= 0.00025 \text{ in/in} = 0.00025$	<p>Example 3. Calculate the strain (ϵ) for a change in length (δ) and a length (L), where</p> <p>$\delta = 0.038$ cm $L = 1.9$ m</p> <p>solution <i>Step 1.</i> Calculate the strain (ϵ) from Eq. (1.2).</p> $\epsilon = \frac{\delta}{L} = \frac{0.038 \text{ cm}}{1.9 \text{ m}}$ $= 0.02 \text{ cm/m} \times 1 \text{ m}/100 \text{ cm}$ $= 0.0002 \text{ m/m} = 0.0002$

Stress-Strain Diagrams. If the stress (σ) is plotted against the strain (ϵ) for an axially loaded bar, the stress-strain diagram for a ductile material in Fig. 1.7 results, where A is proportional limit, B elastic limit, C yield point, D ultimate strength, and F fracture point.

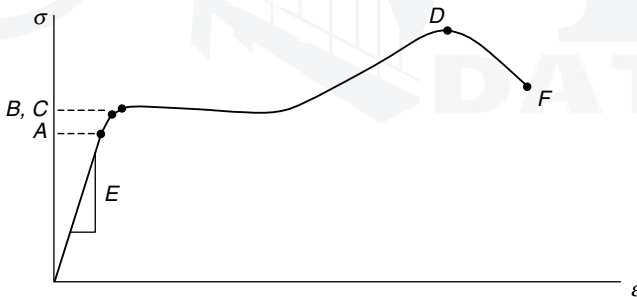

FIGURE 1.7 Stress-strain diagram (ductile material).

The stress-strain diagram is linear up to the proportional limit, and has a slope (E) called the modulus of elasticity. In this region the equation of the straight line up to the proportional limit is called Hooke's law, and is given by Eq. (1.3).

$$\sigma = E \epsilon \quad (1.3)$$

The numerical value for the modulus of elasticity (E) is very large, so the stress-strain diagram is almost vertical to point A , the proportional limit. However, for clarity the horizontal placement of point A has been exaggerated on both Figs. 1.7 and 1.8.

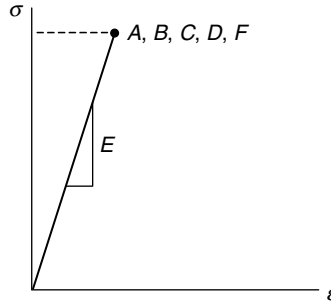

FIGURE 1.8 Stress-strain diagram (brittle material).

The stress-strain diagram for a brittle material is shown in Fig. 1.8, where points *A*, *B*, *C*, *D*, and *F* are all at the same point. This is because failure of a brittle material is virtually instantaneous, giving very little if any warning.

Poisson's Ratio. The law of conservation of mass requires that when an axially loaded bar lengthens as a result of a tensile load, the cross-sectional area of the bar must reduce accordingly. Conversely, if the bar shortens as a result of a compressive load, then the cross-sectional area of the bar must increase accordingly. The amount by which the cross-sectional area reduces or increases is given by a material property called Poisson's ratio (ν), and is defined by Eq. (1.4).

$$\nu = - \frac{\text{lateral strain}}{\text{axial strain}} \quad (1.4)$$

where the lateral strain is the change in any lateral dimension divided by that lateral dimension. For example, if the lateral dimension chosen is the diameter (D) of a circular rod, then the lateral strain could be calculated using Eq. (1.5).

$$\text{lateral strain} = \frac{\Delta D}{D} \quad (1.5)$$

The minus sign in the definition of Poisson's ratio in Eq. (1.4) is needed because the lateral and axial strains will always have opposite signs, meaning that a positive axial strain produces a negative lateral strain, and a negative axial strain produces a positive lateral strain. Strangely enough, Poisson's ratio is bounded between a value of zero and a half.

$$0 \leq \nu \leq \frac{1}{2} \quad (1.6)$$

Again, this is a consequence of the law of conservation of mass that must not be violated during deformation, meaning a change in shape. Values of both the modulus of elasticity (E) and Poisson's ratio (ν) are determined by experiment and can be found in *Marks' Standard Handbook for Mechanical Engineers*.

U.S. Customary	SI/Metric
<p>Example 4. Calculate the change in diameter (ΔD) of a circular steel rod axially loaded in compression, where</p> $D = 2 \text{ in}$ $\varepsilon = -0.00025$ $\nu = 0.28 \text{ (steel)}$ <p>solution</p> <p><i>Step 1.</i> Solve for the lateral strain from Eq. (1.4).</p> $\text{lateral strain} = -\nu \text{ (axial strain)}$ <p><i>Step 2.</i> Substitute Poisson's ratio and the axial strain (ε) that is negative because the rod is in compression.</p> $\begin{aligned} \text{lateral strain} &= -(0.28)(-0.00025) \\ &= 0.0007 \end{aligned}$ <p><i>Step 3.</i> Calculate the change in diameter (D) from Eq. (1.5) using this value for the lateral strain.</p> $\begin{aligned} \Delta D &= D \text{ (lateral strain)} \\ &= (2 \text{ in})(0.0007) \\ &= 0.0014 \text{ in} \end{aligned}$	<p>Example 4. Calculate the change in diameter (ΔD) of a circular steel rod axially loaded in compression, where</p> $D = 5 \text{ cm}$ $\varepsilon = -0.00025$ $\nu = 0.28 \text{ (steel)}$ <p>solution</p> <p><i>Step 1.</i> Solve for the lateral strain from Eq. (1.4).</p> $\text{lateral strain} = -\nu \text{ (axial strain)}$ <p><i>Step 2.</i> Substitute Poisson's ratio and the axial strain that is negative because the rod is in compression.</p> $\begin{aligned} \text{lateral strain} &= -(0.28)(-0.00025) \\ &= 0.0007 \end{aligned}$ <p><i>Step 3.</i> Calculate the change in diameter (D) from Eq. (1.5) using this value for the lateral strain.</p> $\begin{aligned} \Delta D &= D \text{ (lateral strain)} \\ &= (5 \text{ cm})(0.0007) \\ &= 0.0035 \text{ cm} \end{aligned}$

Notice that Poisson's ratio, the axial strain (ε), and the calculated lateral strain are the same for both the U.S. Customary and metric systems.

Deformation. As a consequence of the axial loading shown in Fig. 1.9, there is a corresponding lengthening of the bar (δ), given by Eq. (1.7).

$$\delta = \frac{PL}{AE} \quad (1.7)$$

where δ = change in length of bar (positive for tension, negative for compression)

P = axial force (positive for tension, negative for compression)

L = length of bar

A = cross-sectional area of bar

E = modulus of elasticity of bar material

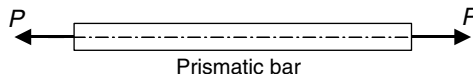

FIGURE 1.9 Axial loading.

Note that Eq. (1.7) is valid only in the region up to the proportional limit as it derives from Eq. (1.3) (Hooke's law), where the axial stress (σ) is substituted from Eq. (1.1) and the axial strain (ε) is substituted from Eq. (1.2), then rearranged to give the elongation (δ) given in Eq. (1.7). This algebraic process is shown in Eq. (1.8).

$$\sigma = E\varepsilon \rightarrow \frac{P}{A} = E \frac{\delta}{L} \rightarrow \delta = \frac{PL}{AE} \quad (1.8)$$

As stated earlier, if the forces acting on the bar were in opposite direction, then the bar would be loaded in compression, producing a compressive normal stress and a shortening of the bar.

U.S. Customary	SI/Metric
<p>Example 5. Calculate the change in length of a circular steel rod of radius (r) and length (L) loaded axially in tension by forces (P), where</p> <p>$P = 15 \text{ kip} = 15,000 \text{ lb}$ $r = 1.5 \text{ in}$ $L = 6 \text{ ft}$ $E = 30 \times 10^6 \text{ lb/in}^2$ (steel)</p> <p>solution <i>Step 1.</i> Calculate the cross-sectional area (A) of the rod.</p> $A = \pi r^2 = \pi (1.5 \text{ in})^2 = 7 \text{ in}^2$ <p><i>Step 2.</i> Substitute the force (P), the length (L), the area (A), and the modulus of elasticity (E) in Eq. (1.7) to give the elongation (δ) as</p> $\delta = \frac{PL}{AE} = \frac{(15,000 \text{ lb})(6 \text{ ft})}{(7 \text{ in}^2)(30 \times 10^6 \text{ lb/in}^2)}$ $= \frac{90,000 \text{ lb} \cdot \text{ft}}{210 \times 10^6 \text{ lb}}$ $= 4.3 \times 10^{-4} \text{ ft} \times 12 \text{ in/ft}$ $= 0.005 \text{ in}$ <p>Example 6. Calculate the compressive axial forces (P) required to shorten an aluminum square bar with sides (a) and length (L) by an amount (δ), where</p> <p>$\delta = 0.03 \text{ in} = 0.0025 \text{ ft}$ $a = 3 \text{ in}$ $L = 3 \text{ ft}$ $E = 11 \times 10^6 \text{ lb/in}^2$ (aluminum)</p> <p>solution <i>Step 1.</i> Calculate the cross-sectional area (A) of the bar.</p> $A = a^2 = (3 \text{ in})^2 = 9 \text{ in}^2$	<p>Example 5. Calculate the change in length of a circular steel rod of radius (r) and length (L) loaded axially in tension by forces (P), where</p> <p>$F = 67.5 \text{ kN} = 67,500 \text{ N}$ $r = 4 \text{ cm} = 0.04 \text{ m}$ $L = 2 \text{ m}$ $E = 207 \times 10^9 \text{ N/m}^2$ (steel)</p> <p>solution <i>Step 1.</i> Calculate the cross-sectional area (A) of the rod.</p> $A = \pi r^2 = \pi (0.04 \text{ m})^2 = 0.005 \text{ m}^2$ <p><i>Step 2.</i> Substitute the force (P), the length (L), the area (A), and the modulus of elasticity (E) into Eq. (1.7) to give the elongation (δ) as</p> $\delta = \frac{PL}{AE} = \frac{(67,500 \text{ N})(2 \text{ m})}{(0.005 \text{ m}^2)(207 \times 10^9 \text{ N/m}^2)}$ $= \frac{135,000 \text{ N} \cdot \text{m}}{1.035 \times 10^9 \text{ N}}$ $= 1.3 \times 10^{-4} \text{ m} \times 1,000 \text{ mm/m}$ $= 0.13 \text{ mm}$ <p>Example 6. Calculate the compressive axial forces (P) required to shorten an aluminum square bar with sides (a) and length (L) by an amount (δ), where</p> <p>$\delta = 0.7 \text{ mm} = 0.0007 \text{ m}$ $a = 8 \text{ cm} = 0.08 \text{ m}$ $L = 1 \text{ m}$ $E = 71 \times 10^9 \text{ N/m}^2$ (aluminum)</p> <p>solution <i>Step 1.</i> Calculate the cross-sectional area (A) of the rod.</p> $A = a^2 = (0.08 \text{ m})^2 = 0.0064 \text{ m}^2$

U.S. Customary	SI/Metric
<p><i>Step 2.</i> Solve for the force (P) in Eq. (1.7) to give</p> $P = \frac{\delta AE}{L}$ $= \frac{(0.0025 \text{ ft})(9 \text{ in}^2)(11 \times 10^6 \text{ lb/in}^2)}{(3 \text{ ft})}$ $= \frac{247,500 \text{ ft} \cdot \text{lb}}{3 \text{ ft}} = 82,500 \text{ lb}$ $= 82.5 \text{ kips}$	<p><i>Step 2.</i> Solve for the force (P) in Eq. (1.7) to give</p> $P = \frac{\delta AE}{L}$ $= \frac{(0.0007 \text{ m})(0.0064 \text{ m}^2)(71 \times 10^9 \text{ N/m}^2)}{(1 \text{ m})}$ $= \frac{318,000 \text{ N} \cdot \text{m}}{1 \text{ m}} = 318,000 \text{ N}$ $= 318 \text{ kN}$

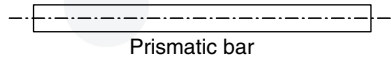

FIGURE 1.10 Thermal strain.

Thermal Strain. If the temperature of the prismatic bar shown in Fig. 1.10 increases, then an axial strain (ϵ_T) will be developed and given by Eq. (1.9),

$$\epsilon_T = \alpha(\Delta T) \quad (1.9)$$

and the bar will lengthen by an amount (δ_T) given by Eq. (1.10).

$$\delta_T = \epsilon_T L = \alpha(\Delta T)L \quad (1.10)$$

where α = coefficient of thermal expansion

ΔT = change in temperature

L = length of bar

For a temperature decrease, the thermal strain (ϵ_T) will be negative as given by Eq. (1.9), and consequently the bar will shorten by an amount (δ_T) as given by Eq. (1.10).

Thermal Stress. If during a temperature change the bar is not constrained, no thermal stress will develop. However, if the bar is constrained from lengthening or shortening, a thermal stress (σ_T) will develop as given by Eq. (1.11).

$$\sigma_T = E\epsilon_T = E\alpha(\Delta T) \quad (1.11)$$

Notice that Eq. (1.11) represents Hooke's law, Eq. (1.3), where the thermal strain (ϵ_T) given by Eq. (1.9) has been substituted for the axial strain (ϵ). Also notice that the cross-sectional area (A) of the bar does not appear in Eqs. (1.9) to (1.11).

U.S. Customary	SI/Metric
<p>Example 7. Calculate the change in length of a steel bar that is heated to 250°F, where</p> $\alpha = 6.5 \times 10^{-6} \text{ in/in} \cdot ^\circ\text{F (steel)}$ $L = 9 \text{ ft}$ <p>solution</p> <p><i>Step 1.</i> Calculate the change in length (δ_T) owing to temperature increase using Eq. (1.10)</p> $\delta_T = \alpha (\Delta T) L$ $= (6.5 \times 10^{-6} \text{ in/in} \cdot ^\circ\text{F})(260^\circ\text{F})(9 \text{ ft})$ $= 0.015 \text{ ft} = 0.18 \text{ in}$ <p>Example 8. If the bar in Example 7 is constrained, then calculate the thermal stress (σ_T) developed, where</p> $E = 30 \times 10^6 \text{ lb/in}^2 \text{ (steel)}$ <p>solution</p> <p><i>Step 1.</i> Calculate the thermal strain (ϵ_T) using Eq. (1.9).</p> $\epsilon_T = \alpha (\Delta T)$ $= (6.5 \times 10^{-6} \text{ in/in} \cdot ^\circ\text{F})(260^\circ\text{F})$ $= 0.00169$ <p><i>Step 2.</i> Substitute this thermal strain in Eq. (1.11) to give the thermal stress.</p> $\sigma_T = E\epsilon_T = (30 \times 10^6 \text{ lb/in}^2)(0.00169)$ $= 50,700 \text{ lb/in}^2 = 50.7 \text{ ksi}$	<p>Example 7. Calculate the change in length of a steel bar that is heated to 125°C, where</p> $\alpha = 12 \times 10^{-6} \text{ cm/cm} \cdot ^\circ\text{C (steel)}$ $L = 3 \text{ m}$ <p>solution</p> <p><i>Step 1.</i> Calculate the change in length (δ_T) owing to temperature increase using Eq. (1.10).</p> $\delta_T = \alpha (\Delta T) L$ $= (12 \times 10^{-6} \text{ m/m} \cdot ^\circ\text{C})(125^\circ\text{C})(3 \text{ m})$ $= 0.0045 \text{ m} = 0.45 \text{ cm}$ <p>Example 8. If the bar in Example 7 is constrained, then calculate the thermal stress (σ_T) developed, where</p> $E = 207 \times 10^9 \text{ N/m}^2 \text{ (steel)}$ <p>solution</p> <p><i>Step 1.</i> Calculate the thermal strain (ϵ_T) using Eq. (1.9).</p> $\epsilon_T = \alpha (\Delta T)$ $= (12 \times 10^{-6} \text{ m/m} \cdot ^\circ\text{C})(125^\circ\text{C})$ $= 0.0015$ <p><i>Step 2.</i> Substitute this thermal strain in Eq. (1.11) to give the thermal stress.</p> $\sigma_T = E\epsilon_T = (207 \times 10^9 \text{ N/m}^2)(0.0015)$ $= 310,500,000 \text{ N/m}^2 = 310.5 \text{ MPa}$

1.3 DIRECT SHEAR

The overlapping bars in Fig. 1.11 are held together by a single rivet as shown.

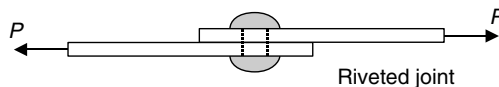

FIGURE 1.11 Direct shear loading.

Stress. If the rivet is cut in half at the overlap to expose the cross-sectional area (A) of the rivet, then Fig. 1.12 shows the resulting free-body-diagram.

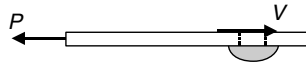

FIGURE 1.12 Free-body-diagram.

A shear force (V) acts over the cross section of the rivet and by static equilibrium equals the magnitude of the force (P). As a consequence a shear stress (τ) is developed in the rivet as given by Eq. (1.12).

$$\tau = \frac{V}{A} = \frac{P}{A_{\text{rivet}}} \quad (1.12)$$

The unit of shear stress (τ) is the same as that for normal stress (σ), that is, pound per square inch (psi) in the U.S. Customary System and newton per square meter, or pascal (Pa), in the metric system.

Suppose the overlapping joint is held together by two rivets as in Fig. 1.13.

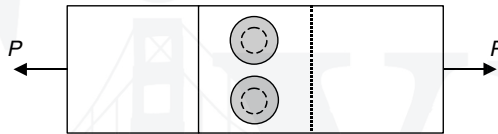

FIGURE 1.13 Two-rivet joint (top view).

If both the rivets are cut in half at the overlap to expose the cross-sectional areas A of the rivets, then Fig. 1.14 shows the resulting free-body-diagram.



FIGURE 1.14 Free-body-diagram.

A shear force (V) acts over the cross section of each rivet and so by static equilibrium these two shear forces together equal the magnitude of the force (P), which means each is half the force (P). The shear stress (τ) that is developed in each rivet is given by Eq. (1.13).

$$\tau = \frac{V}{A} = \frac{P/2}{A_{\text{rivet}}} = \frac{P}{2A_{\text{rivet}}} \quad (1.13)$$

As the number of rivets increase, the shear stress in each rivet is reduced.

U.S. Customary	SI/Metric
<p>Example 1. Determine the shear stress (τ) in one of the four rivets of an overlapping joint, where</p> $P = 10 \text{ kip} = 10,000 \text{ lb}$ $D_{\text{rivet}} = 0.25 \text{ in} = 2 r_{\text{rivet}}$ <p>solution</p> <p><i>Step 1.</i> Calculate the cross-sectional area (A) of each rivet.</p> $A_{\text{rivet}} = \pi r^2 = \pi(0.125 \text{ in})^2 = 0.05 \text{ in}^2$ <p><i>Step 2.</i> As there are four rivets that must carry the force (P), the shear force (V) for each rivet is</p> $4V = P \rightarrow V = \frac{P}{4} = \frac{10,000 \text{ lb}}{4}$ $= 2,500 \text{ lb}$ <p><i>Step 3.</i> Using Eq. (1.13) calculate the shear stress (τ).</p> $\tau = \frac{V}{A_{\text{rivet}}} = \frac{2,500 \text{ lb}}{0.05 \text{ in}^2}$ $= 50,000 \text{ lb/in}^2 = 50 \text{ kpsi}$	<p>Example 1. Determine the shear stress (τ) in one of the four rivets of an overlapping joint, where</p> $P = 45 \text{ kN} = 45,000 \text{ N}$ $D_{\text{rivet}} = 0.6 \text{ cm} = 0.006 \text{ m} = 2 r_{\text{rivet}}$ <p>solution</p> <p><i>Step 1.</i> Calculate the cross-sectional area (A) of each rivet.</p> $A_{\text{rivet}} = \pi r^2 = \pi(0.003 \text{ m})^2 = 0.00003 \text{ m}^2$ <p><i>Step 2.</i> As there are four rivets that must carry the force (P), the shear force (V) for each rivet is</p> $4V = P \rightarrow V = \frac{P}{4} = \frac{45,000 \text{ N}}{4}$ $= 11,250 \text{ N}$ <p><i>Step 3.</i> Using Eq. (1.13) calculate the shear stress (τ).</p> $\tau = \frac{V}{A_{\text{rivet}}} = \frac{11,250 \text{ N}}{0.00003 \text{ m}^2}$ $= 375,000,000 \text{ N/m}^2 = 375 \text{ MPa}$

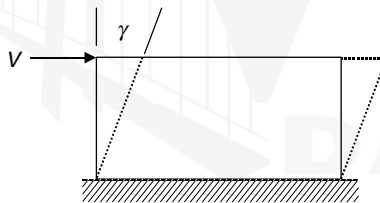

FIGURE 1.15 Rectangular plate in shear.

Strain. The shear force (V) acting on the rectangular plate in Fig. 1.15 will, if one side of the plate is held fixed, cause the plate to deform into a parallelogram as shown.

The change in the 90° angle, measured in radians, is called the shear strain (γ). So the shear strain is dimensionless. If the area of the fixed edge of the plate is labeled (A_{fix}), then the shear stress (τ) is given by Eq. (1.14).

$$\tau = \frac{V}{A_{\text{fix}}} \quad (1.14)$$

Stress-Strain Diagrams. If shear stress (τ) is plotted against shear strain (γ), it gives a shear stress-strain diagram as shown in Fig. 1.16, which gives the shear stress-strain diagram for a ductile material where points A , B , C , D , and F are analogous to the normal

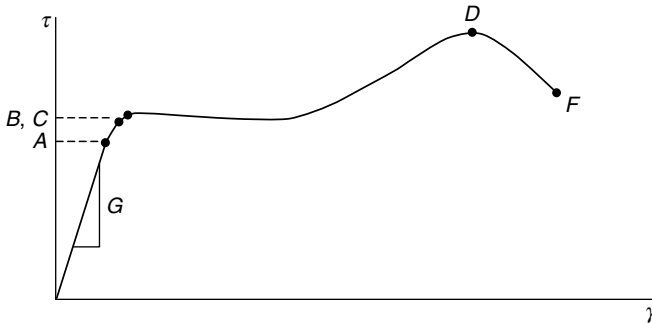

FIGURE 1.16 Shear stress-strain diagram (ductile material).

stress-strain diagram, that is,

- A proportional limit
- B elastic limit
- C yield point
- D ultimate strength
- F fracture point

The shear stress-strain diagram is also linear up to the proportional limit; however, the slope (G) is called the shear modulus of elasticity. In this region the equation of the straight line up to the proportional limit is called Hooke's Law for Shear, and is given by Eq. (1.15).

$$\tau = G \gamma \quad (1.15)$$

The shear modulus of elasticity (G) is of the same order of magnitude as the modulus of elasticity (E), so the diagram is virtually straight up to point A.

Similarly, the shear stress-strain diagram for a brittle material is shown in Fig. 1.17 where points A, B, C, D, and F are all at the same point. As stated earlier, this is because failure of a brittle material is virtually instantaneous giving very little or no warning.

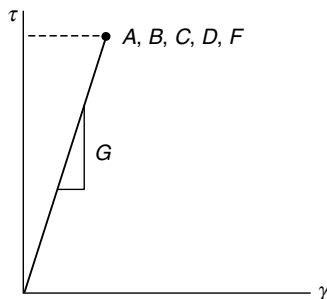

FIGURE 1.17 Shear stress-strain diagram (brittle material).

Relationship among E , G , and ν . The modulus of elasticity (E), shear modulus of elasticity (G), and Poisson's ratio (ν) are not independent but related by Eq. (1.16).

$$G = \frac{E}{2(1 + \nu)} \quad (1.16)$$

This is a remarkable relationship between material properties, and to the author's knowledge there is no other such relationship in engineering.

U.S. Customary	SI/Metric
<p>Example 2. Given the modulus of elasticity (E) and Poisson's ratio (ν), calculate the shear modulus of elasticity (G), where</p> <p>$E = 30 \times 10^6 \text{ lb/in}^2$ (steel) $\nu = 0.28$ (steel)</p> <p>solution <i>Step 1.</i> Substitute the modulus of elasticity (E) and Poisson's ratio (ν) into Eq. (1.16).</p> $G = \frac{E}{2(1 + \nu)} = \frac{30 \times 10^6 \text{ lb/in}^2}{2(1 + 0.28)}$ $= \frac{30 \times 10^6 \text{ lb/in}^2}{2.56}$ $= 11.7 \times 10^6 \text{ lb/in}^2$	<p>Example 2. Given the modulus of elasticity (E) and Poisson's ratio (ν), calculate the shear modulus of elasticity (G), where</p> <p>$E = 207 \times 10^9 \text{ N/m}^2$ (steel) $\nu = 0.28$ (steel)</p> <p>solution <i>Step 1.</i> Substitute the modulus of elasticity (E) and Poisson's ratio (ν) into Eq. (1.16).</p> $G = \frac{E}{2(1 + \nu)} = \frac{207 \times 10^9 \text{ N/m}^2}{2(1 + 0.28)}$ $= \frac{207 \times 10^9 \text{ N/m}^2}{2.56}$ $= 80.8 \times 10^9 \text{ N/m}^2$

Punching Holes. One of the practical applications of direct shear is the punching of holes in sheet metal as depicted in Fig. 1.18.

The holes punched are usually round so the shear area (A) is the surface area of the inside of the hole, or the surface area of the edge of the circular plug that is removed. Therefore, the shear area (A) is given by Eq. (1.17).

$$A = 2\pi r t \quad (1.17)$$

where (r) is the radius of the hole and (t) is the thickness of the plate.

In order to punch a hole, the ultimate shear strength (S_{su}) of the material that is half the ultimate tensile strength (S_{ut}) must be reached by the force (F) of the punch. Using the definition of shear stress (τ) in Eq. (1.18)

$$\tau = \frac{V}{A} \quad (1.18)$$

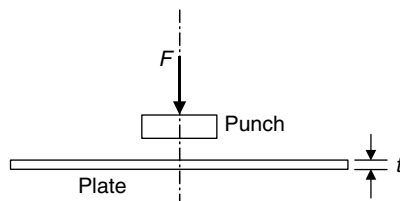

FIGURE 1.18 Hole punching.

and substituting the force (F) for the shear force (V), area (A) for a round hole from Eq. (1.17), the ultimate shear strength (S_{su}) can be expressed by Eq. (1.19).

$$S_{su} = \frac{F}{2\pi rt} \tag{1.19}$$

Solving for the required punching force (F) in Eq. (1.19) gives Eq. (1.20).

$$F = S_{su}(2\pi rt) \tag{1.20}$$

U.S. Customary	SI/Metric
<p>Example 3. Calculate the required punching force (F) for round hole, where</p> <p>$S_{su} = 35,000$ psi (aluminum) $r = 0.375$ in $t = 0.25$ in</p> <p>solution <i>Step 1.</i> Calculate the required punching force (F) from Eq. (1.20).</p> <p>$F = S_{su}(2\pi rt)$ $= (35,000 \text{ psi})(2\pi (0.375 \text{ in})(0.25 \text{ in}))$ $= (35,000 \text{ psi})(0.589 \text{ in}^2)$ $= 20,620 \text{ lb} = 20.6 \text{ kip}$</p>	<p>Example 3. Calculate the required punching force (F) for round hole, where</p> <p>$S_{su} = 240$ MPa (aluminum) $r = 1$ cm = 0.01 m $t = 0.65$ cm = 0.0065 m</p> <p>solution <i>Step 1.</i> Calculate the required punching force (F) from Eq. (1.20).</p> <p>$F = S_{su}(2\pi rt)$ $= (240 \text{ MPa})(2\pi (0.01 \text{ m})(0.0065 \text{ m}))$ $= (240 \text{ MPa})(0.00041 \text{ m}^2)$ $= 98,020 \text{ N} = 98.0 \text{ kN}$</p>

1.4 TORSION

Figure 1.19 shows a circular shaft acted upon by opposing torques (T), causing the shaft to be in torsion. This type of loading produces a shear stress in the shaft, thereby causing one end of the shaft to twist about the axis relative to the other end.

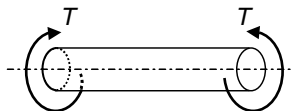

FIGURE 1.19 Torsion.

Stress. The two opposing torques (T) produce a twisting load along the axis of the shaft, resulting in a shear stress distribution (τ) as given by Eq. (1.21),

$$\tau = \frac{Tr}{J} \quad 0 \leq r \leq R \tag{1.21}$$

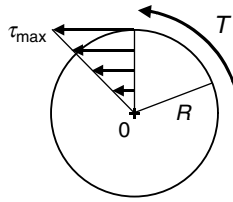

FIGURE 1.20 Shear stress distribution.

where (r) is the distance from the center of the shaft and (R) is the outside radius. The distribution given by Eq. (1.21) is linear, as shown in Fig. 1.20, with the maximum shear stress (τ_{\max}) occurring at the surface of the shaft ($r = R$), with zero shear stress at the center ($r = 0$).

Note that Eq. (1.21) is valid only for circular cross sections. For other cross-sectional geometries consult *Marks' Standard Handbook for Mechanical Engineers*.

The quantity (J) in Eq. (1.21) is called the polar moment of inertia, and for a solid circular shaft of radius (R) is given by Eq. (1.22).

$$J = \frac{1}{2}\pi R^4 \quad (1.22)$$

Very little of the torsional load is carried by material near the center of the shaft, so hollow shafts are more efficient. For a hollow circular shaft where the inside radius is (R_i) and the outside radius is (R_o), the polar moment of inertia (J) is given by Eq. (1.23).

$$J = \frac{1}{2}\pi (R_o^4 - R_i^4) \quad (1.23)$$

U.S. Customary	SI/Metric
<p>Example 1. Determine the maximum shear stress (τ_{\max}) for a solid circular shaft, where</p> $T = 5,000 \text{ ft} \cdot \text{lb} = 60,000 \text{ in} \cdot \text{lb}$ $D = 4 \text{ in} = 2R$ <p>solution</p> <p><i>Step 1.</i> Calculate the polar moment of inertia (J) of the shaft using Eq. (1.22).</p> $J = \frac{1}{2}\pi R^4 = \frac{1}{2}\pi (2 \text{ in})^4$ $= 25.13 \text{ in}^4$ <p><i>Step 2.</i> Substitute this value for (J), the torque (T), and the outside radius (R) in Eq. (1.21).</p> $\tau_{\max} = \frac{TR}{J} = \frac{(60,000 \text{ in} \cdot \text{lb})(2 \text{ in})}{25.13 \text{ in}^4}$ $= 4,775 \text{ lb/in}^2 = 4.8 \text{ kpsi}$	<p>Example 1. Determine the maximum shear stress (τ_{\max}) for a solid circular shaft, where</p> $T = 7,500 \text{ N} \cdot \text{m}$ $D = 10 \text{ cm} = 0.1 \text{ m} = 2R$ <p>solution</p> <p><i>Step 1.</i> Calculate the polar moment of inertia (J) of the shaft using Eq. (1.22).</p> $J = \frac{1}{2}\pi R^4 = \frac{1}{2}\pi (0.05 \text{ m})^4$ $= 0.00000982 \text{ m}^4$ <p><i>Step 2.</i> Substitute this value for (J), the torque (T), and the outside radius (R) in Eq. (1.21).</p> $\tau_{\max} = \frac{TR}{J} = \frac{(7,500 \text{ N} \cdot \text{m})(0.05 \text{ m})}{0.00000982 \text{ m}^4}$ $= 38,200,000 \text{ N/m}^2 = 38.2 \text{ MPa}$

U.S. Customary	SI/Metric
<p>Example 2. Determine the shear stress (τ_i) at the inside surface of a hollow circular shaft, where</p> $T = 8,000 \text{ ft} \cdot \text{lb} = 96,000 \text{ in} \cdot \text{lb}$ $D_o = 4 \text{ in} = 2R_o$ $D_i = 2 \text{ in} = 2R_i$ <p>solution</p> <p><i>Step 1.</i> Calculate the polar moment of inertia (J) of the shaft using Eq. (1.23).</p> $J = \frac{1}{2} \pi (R_o^4 - R_i^4)$ $= \frac{1}{2} \pi ((2 \text{ in})^4 - (1 \text{ in})^4)$ $= 23.56 \text{ in}^4$ <p><i>Step 2.</i> Substitute this value for (J), the torque (T), and the inside radius (R_i) into Eq. (1.21).</p> $\tau_i = \frac{TR_i}{J} = \frac{(96,000 \text{ in} \cdot \text{lb})(1 \text{ in})}{23.56 \text{ in}^4}$ $= 4,074 \text{ lb/in}^2 = 4.1 \text{ kpsi}$	<p>Example 2. Determine the shear stress (τ_i) at the inside surface of a hollow circular shaft, where</p> $T = 12,000 \text{ N} \cdot \text{m}$ $D_o = 10 \text{ cm} = 0.1 \text{ m} = 2R_o$ $D_i = 5 \text{ cm} = 0.05 \text{ m} = 2R_i$ <p>solution</p> <p><i>Step 1.</i> Calculate the polar moment of inertia (J) of the shaft using Eq. (1.23).</p> $J = \frac{1}{2} \pi (R_o^4 - R_i^4)$ $= \frac{1}{2} \pi ((0.05 \text{ m})^4 - (0.025 \text{ m})^4)$ $= 0.00000920 \text{ m}^4$ <p><i>Step 2.</i> Substitute this value for (J), the torque (T), and the inside radius (R_i) in Eq. (1.21).</p> $\tau_i = \frac{TR_i}{J} = \frac{(12,000 \text{ N} \cdot \text{m})(0.025 \text{ m})}{0.00000920 \text{ m}^4}$ $= 32,600,000 \text{ N/m}^2 = 32.6 \text{ MPa}$

Level of Torque Reduction. For the geometry of Example 2, the outside radius (R_o) is twice the inside radius (R_i). It is interesting that reduction in torque carrying capability of the hollow shaft compared to the solid shaft is small. This is because the material near the center of the shaft carries very little of the shear stress, or load, produced by the applied torque (T). It is instructive to determine the exact value of this reduction.

Start with the fact that the maximum shear stress (τ_{\max}) will be the same for both the shafts, because they are made of the same material and the outside radius (R_o) is the same. This fact is shown mathematically in Eq. (1.21) to both the solid shaft and the hollow shaft. This fact is shown mathematically in Eq. (1.24) as

$$\frac{T_{\text{solid}} R_o}{J_{\text{solid}}} = \frac{T_{\text{hollow}} R_o}{J_{\text{hollow}}} \quad (1.24)$$

The outside radius (R_o) cancels on both sides, so Eq. (1.24) can be rearranged to give the ratio of the torque carried by the hollow shaft (T_{hollow}) divided by the torque carried by the solid shaft (T_{solid}).

$$\frac{T_{\text{hollow}}}{T_{\text{solid}}} = \frac{J_{\text{hollow}}}{J_{\text{solid}}} \quad (1.25)$$

Substituting for the respective polar moments of inertia from Eqs. (1.22) and (1.23), and performing some simple algebra, gives

$$\frac{T_{\text{hollow}}}{T_{\text{solid}}} = \frac{\frac{1}{2} \pi (R_o^4 - R_i^4)}{\frac{1}{2} \pi (R_o^4)} = \frac{(R_o^4 - R_i^4)}{(R_o^4)} = \frac{(R_o^4)}{(R_o^4)} - \frac{(R_i^4)}{(R_o^4)} = 1 - \left(\frac{R_i}{R_o}\right)^4 \quad (1.26)$$

For Example 2, the ratio of the inside radius to the outside radius is one-half. So Eq. (1.26) becomes

$$\frac{T_{\text{hollow}}}{T_{\text{solid}}} = 1 - \left(\frac{R_i}{R_o}\right)^4 = 1 - \left(\frac{1}{2}\right)^4 = 1 - \frac{1}{16} = \frac{15}{16} = 0.9375 = 93.75\% \quad (1.27)$$

So what is remarkable is that removing such a large portion of the shaft only reduces the torque carrying capacity by just a little over 6 percent. Note that Eq. (1.27) is a general relationship and can be used for any ratio of inside and outside diameters.

Strain. As a consequence of the torsional loading on the circular shaft, there is a twisting of the shaft along its geometric axis. This produces a shear strain (γ) which is given in Eq. (1.28), without providing the details,

$$\gamma = \frac{r\phi}{L} \quad 0 \leq r \leq R \quad (1.28)$$

where (ϕ) is the angle of twist of the shaft, measured in radians.

Deformation. The angle of twist (ϕ) is given by Eq. (1.29).

$$\phi = \frac{TL}{GJ} \quad (1.29)$$

and shown graphically in Fig. 1.21.

Note that Eq. (1.29) is valid only in the region up to the proportional limit as it derives from Hooke's law for shear, Eq. (1.15). The shear stress (τ) is substituted from Eq. (1.21) and the shear strain (γ) is substituted from Eq. (1.28), then rearranged to give the angle of twist (ϕ) given in Eq. (1.29). This algebraic process is shown in Eq. (1.30).

$$\tau = G\gamma \rightarrow \frac{Tr}{J} = G \frac{r\phi}{L} \rightarrow \phi = \frac{TL}{GJ} \quad (1.30)$$

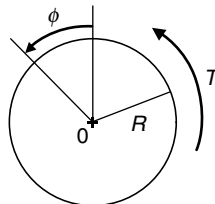

FIGURE 1.21 Angle of twist.

U.S. Customary	SI/Metric
<p>Example 3. Calculate the angle of twist (ϕ) for a solid circular shaft, where</p> $T = 6,000 \text{ ft} \cdot \text{lb} = 72,000 \text{ in} \cdot \text{lb}$ $D = 3 \text{ in} = 2R$ $L = 6 \text{ ft} = 72 \text{ in}$ $G = 11.7 \times 10^6 \text{ lb/in}^2 \text{ (steel)}$ <p>solution</p> <p><i>Step 1.</i> Calculate the polar moment of inertia (J) of the shaft using Eq. (1.22).</p> $J = \frac{1}{2} \pi R^4 = \frac{1}{2} \pi (1.5 \text{ in})^4$ $= 7.95 \text{ in}^4$ <p><i>Step 2.</i> Substitute this value of the polar moment of inertia (J), the torque (T), the length (L), and the shear modulus of elasticity (G) into Eq. (1.29) to give the angle of twist (ϕ) as</p> $\phi = \frac{TL}{GJ}$ $= \frac{(72,000 \text{ in} \cdot \text{lb})(72 \text{ in})}{(11.7 \times 10^6 \text{ lb/in}^2)(7.95 \text{ in}^4)}$ $= \frac{5,184,000 \text{ lb} \cdot \text{in}^2}{93,015,000 \text{ lb} \cdot \text{in}^2}$ $= 0.056 \text{ rad}$ <p>Example 4. Determine the maximum torque (T_{\max}) that can be applied to a solid circular shaft if there is a maximum allowable shear stress (τ_{\max}) and a maximum allowable angle of twist (ϕ), where</p> $\tau_{\max} = 60 \text{ kpsi} = 60,000 \text{ lb/in}^2$ $\phi_{\max} = 1.5^\circ = 0.026 \text{ rad}$ $D = 6 \text{ in} = 2R$ $L = 3 \text{ ft} = 36 \text{ in}$ $G = 4.1 \times 10^6 \text{ lb/in}^2 \text{ (aluminum)}$ <p>solution</p> <p><i>Step 1.</i> For a maximum shear stress (τ_{\max}), solve for the maximum torque (T_{\max}) in Eq. (1.21) to give</p> $T_{\max} = \frac{\tau_{\max} J}{R}$ <p><i>Step 2.</i> Calculate the polar moment of inertia (J) of the shaft using Eq. (1.22).</p> $J = \frac{1}{2} \pi R^4 = \frac{1}{2} \pi (3 \text{ in})^4$ $= 127.2 \text{ in}^4$	<p>Example 3. Calculate the angle of twist (ϕ) for a solid circular shaft, where</p> $T = 9,000 \text{ N} \cdot \text{m}$ $D = 8 \text{ cm} = 0.08 \text{ m} = 2R$ $L = 2 \text{ m}$ $G = 80.8 \times 10^9 \text{ N/m}^2 \text{ (steel)}$ <p>solution</p> <p><i>Step 1.</i> Calculate the polar moment of inertia (J) of the shaft using Eq. (1.22).</p> $J = \frac{1}{2} \pi R^4 = \frac{1}{2} \pi (0.04 \text{ m})^4$ $= 0.0000402 \text{ m}^4$ <p><i>Step 2.</i> Substitute this value of the polar moment of inertia (J), the torque (T), the length (L), and the shear modulus of elasticity (G) into Eq. (1.29) to give the angle of twist (ϕ) as</p> $\phi = \frac{TL}{GJ}$ $= \frac{(9,000 \text{ N} \cdot \text{m})(2 \text{ m})}{(80.8 \times 10^9 \text{ N/m}^2)(0.0000402 \text{ m}^4)}$ $= \frac{18,000 \text{ N} \cdot \text{m}^2}{323,200 \text{ N} \cdot \text{m}^2}$ $= 0.056 \text{ rad}$ <p>Example 4. Determine the maximum torque (T_{\max}) that can be applied to a solid circular shaft if there is a maximum allowable shear stress (τ_{\max}) and a maximum allowable angle of twist (ϕ), where</p> $\tau_{\max} = 410 \text{ MPa} = 410,000,000 \text{ N/m}^2$ $\phi_{\max} = 1.5^\circ = 0.026 \text{ rad}$ $D = 15 \text{ cm} = 0.15 \text{ m} = 2R$ $L = 1 \text{ m}$ $G = 26.7 \times 10^9 \text{ N/m}^2 \text{ (aluminum)}$ <p>solution</p> <p><i>Step 1.</i> For a maximum shear stress (τ_{\max}), solve for the maximum torque (T_{\max}) in Eq. (1.21) to give</p> $T_{\max} = \frac{\tau_{\max} J}{R}$ <p><i>Step 2.</i> Calculate the polar moment of inertia (J) of the shaft using Eq. (1.22).</p> $J = \frac{1}{2} \pi R^4 = \frac{1}{2} \pi (0.075 \text{ m})^4$ $= 0.0000497 \text{ m}^4$

U.S. Customary	SI/Metric
<p><i>Step 3.</i> Using this value for the polar moment of inertia (J), and the maximum allowable shear stress (τ_{\max}), substitute in the equation developed in Step 1.</p> $T_{\max} = \frac{\tau_{\max} J}{R}$ $= \frac{(60,000 \text{ lb/in}^2)(127.2 \text{ in}^4)}{(3 \text{ in})}$ $= \frac{7,632,000 \text{ lb} \cdot \text{in}^2}{3 \text{ in}}$ $= 2,544,000 \text{ in} \cdot \text{lb}$ $= 212 \text{ ft} \cdot \text{kip}$	<p><i>Step 3.</i> Using this value for the polar moment of inertia (J), and the maximum allowable shear stress (τ_{\max}), substitute into the equation determined in Step 1.</p> $T_{\max} = \frac{\tau_{\max} J}{R}$ $= \frac{(4.1 \times 10^8 \text{ N/m}^2)(4.97 \times 10^{-5} \text{ m}^4)}{(0.075 \text{ m})}$ $= \frac{20,377 \text{ N} \cdot \text{m}^2}{0.075 \text{ m}}$ $= 271,693 \text{ N} \cdot \text{m}$ $= 272 \text{ kN} \cdot \text{m}$
<p><i>Step 4.</i> For a maximum angle of twist (ϕ_{\max}), solve for the maximum torque (T_{\max}) in Eq. (1.29) to give</p>	<p><i>Step 4.</i> For a maximum angle of twist (ϕ_{\max}), solve for the maximum torque (T_{\max}) in Eq. (1.29) to give</p>
$T_{\max} = \frac{\phi_{\max} GJ}{L} = \frac{\phi_{\max}}{L} \times GJ$	$T_{\max} = \frac{\phi_{\max} GJ}{L} = \frac{\phi_{\max}}{L} \times GJ$
<p>where the quantity (GJ) is called the torsional stiffness.</p>	<p>where the quantity (GJ) is called the torsional stiffness.</p>
<p><i>Step 5.</i> Using the polar moment of inertia (J) calculated earlier and the shear modulus of elasticity (G), calculate the torsional stiffness.</p>	<p><i>Step 5.</i> Using the polar moment of inertia (J) calculated earlier and the shear modulus of elasticity (G), calculate the torsional stiffness.</p>
$GJ = (4.1 \times 10^6 \text{ lb/in}^2)(127.2 \text{ in}^4)$ $= 5.2 \times 10^8 \text{ lb} \cdot \text{in}^2$	$GJ = (26.7 \times 10^9 \text{ N/m}^2)(4.97 \times 10^{-5} \text{ m}^4)$ $= 1.3 \times 10^6 \text{ N} \cdot \text{m}^2$
<p><i>Step 6.</i> Substitute the given maximum allowable angle of twist (ϕ_{\max}), the torsional stiffness (GJ) just calculated, and the length (L) in the equation of Step 4 to give</p>	<p><i>Step 6.</i> Substitute the given maximum allowable angle of twist (ϕ_{\max}), the torsional stiffness (GJ) just calculated, and the length (L) into the equation of Step 4 to give</p>
$T_{\max} = \frac{\phi_{\max}}{L} \times GJ$ $= \frac{(0.026 \text{ rad})}{(36 \text{ in})} (5.2 \times 10^8 \text{ lb} \cdot \text{in}^2)$ $= \left(7.2 \times 10^{-4} \frac{1}{\text{in}}\right) (5.2 \times 10^8 \text{ lb} \cdot \text{in}^2)$ $= 374,400 \text{ in} \cdot \text{lb}$ $= 31 \text{ ft} \cdot \text{kip}$	$T_{\max} = \frac{\phi_{\max}}{L} \times GJ$ $= \frac{(0.026 \text{ rad})}{(1 \text{ m})} (1.3 \times 10^6 \text{ N} \cdot \text{m}^2)$ $= \left(2.6 \times 10^{-2} \frac{1}{\text{m}}\right) (1.3 \times 10^6 \text{ N} \cdot \text{m}^2)$ $= 33,800 \text{ N} \cdot \text{m}$ $= 34 \text{ kN} \cdot \text{m}$
<p><i>Step 7.</i> As the maximum torque (T_{\max}) associated with the maximum angle of twist (ϕ_{\max}) is smaller than that for the maximum shear stress (τ_{\max}), angle of twist governs, so</p>	<p><i>Step 7.</i> As the maximum torque (T_{\max}) associated with the maximum angle of twist (ϕ_{\max}) is smaller than that for the maximum shear stress (τ_{\max}), angle of twist governs, so</p>
$T_{\max} = 31 \text{ ft} \cdot \text{kip}$	$T_{\max} = 34 \text{ kN} \cdot \text{m}$

Thin-walled Tubes. For either a solid or hollow circular shaft, Eq. (1.21) gives the shear stress (τ) because of torsion. For thin-walled tubes of any shape Eq. (1.31) gives the shear stress (τ) in the wall of the tube owing to an applied torque (T).

$$\tau = \frac{T}{2 A_m t} \quad (1.31)$$

where A_m is area enclosed by the median line of the tube cross section and t is thickness of the tube wall.

Surprisingly, the angle of twist (ϕ) for thin-walled tubes is the same as presented in Eq. (1.29), that is

$$\phi = \frac{TL}{GJ} \quad (1.32)$$

However, each thin-walled tube shape will have a different polar moment of inertia (J).

Equations (1.31) and (1.32) are useful for all kinds of thin-walled shapes: elliptical, triangular, and box shapes, to name just a few. For example, consider the thin-walled rectangular box section shown in Fig. 1.22.

The rectangular tube in Fig. 1.22 has two different wall thicknesses, with the area enclosed by the median line given as

$$A_m = bh \quad (1.33)$$

and the polar moment of inertia (J) given as

$$J = \frac{2b^2 h^2 t_1 t_2}{b t_1 + h t_2} \quad (1.34)$$

There are two thicknesses, so use the smaller value in Eq. (1.31) to find shear stress (τ).

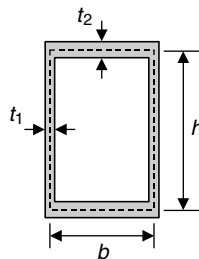

FIGURE 1.22 Thin-walled rectangular tube.

U.S. Customary	SI/Metric
<p>Example 5. Calculate shear stress (τ) and the angle of twist (ϕ) for a thin-walled rectangular tube, similar to that shown in Fig. 1.22, where</p> $T = 4,000 \text{ ft} \cdot \text{lb} = 48,000 \text{ in} \cdot \text{lb}$ $b = 4 \text{ in}$ $h = 8 \text{ in}$ $t_1 = 0.25 \text{ in}$ $t_2 = 0.5 \text{ in}$ $L = 2.5 \text{ ft} = 30 \text{ in}$ $G = 11.7 \times 10^6 \text{ lb/in}^2 \text{ (steel)}$ <p>solution</p> <p><i>Step 1.</i> Calculate the area (A_m) enclosed by the median using Eq. (1.33).</p> $A_m = bh = (4 \text{ in})(8 \text{ in}) = 32 \text{ in}^2$ <p><i>Step 2.</i> Substitute the torque (T), area (A_m), and the thickness (t) in Eq. (1.31) to give the shear stress (τ) as</p> $\begin{aligned} \tau &= \frac{T}{2 A_m t_1} = \frac{48,000 \text{ in} \cdot \text{lb}}{2(32 \text{ in}^2)(0.25 \text{ in})} \\ &= \frac{48,000 \text{ in} \cdot \text{lb}}{(16 \text{ in}^3)} = 3,000 \text{ lb/in}^2 \\ &= 3 \text{ kpsi} \end{aligned}$ <p><i>Step 3.</i> Calculate the polar moment of inertia (J) for the rectangular tube using Eq. (1.34).</p> $\begin{aligned} J &= \frac{2b^2 h^2 t_1 t_2}{bt_1 + ht_2} \\ &= \frac{2(4 \text{ in})^2 (8 \text{ in})^2 (0.25 \text{ in})(0.5 \text{ in})}{(4 \text{ in})(0.25 \text{ in}) + (8 \text{ in})(0.5 \text{ in})} \\ &= \frac{256 \text{ in}^6}{5 \text{ in}^2} = 51.2 \text{ in}^4 \end{aligned}$ <p><i>Step 4.</i> Substitute the torque (T), length (L), shear modulus of elasticity (G), and the polar moment of inertia (J) just calculated into Eq. (1.32) to find the angle of twist (ϕ).</p> $\begin{aligned} \phi &= \frac{TL}{GJ} \\ &= \frac{(48,000 \text{ in} \cdot \text{lb})(30 \text{ in})}{(11.7 \times 10^6 \text{ lb/in}^2)(51.2 \text{ in}^4)} \\ &= \frac{864,000 \text{ lb} \cdot \text{in}^2}{599,000,000 \text{ lb} \cdot \text{in}^2} \\ &= 0.0024 \text{ rad} \end{aligned}$	<p>Example 5. Calculate shear stress (τ) and the angle of twist (ϕ) for a thin-walled rectangular tube, similar to that shown in Fig. 1.22, where</p> $T = 6,000 \text{ N} \cdot \text{m}$ $b = 10 \text{ cm} = 0.1 \text{ m}$ $h = 20 \text{ cm} = 0.2 \text{ m}$ $t_1 = 0.6 \text{ cm} = 0.006 \text{ m}$ $t_2 = 1.2 \text{ cm} = 0.012 \text{ m}$ $L = 0.8 \text{ m}$ $G = 80.8 \times 10^9 \text{ N/m}^2 \text{ (steel)}$ <p>solution</p> <p><i>Step 1.</i> Calculate the area (A_m) enclosed by the median using Eq. (1.33).</p> $A_m = bh = (0.1 \text{ m})(0.2 \text{ m}) = 0.02 \text{ m}^2$ <p><i>Step 2.</i> Substitute the torque (T), area (A_m), and the thickness (t) in Eq. (1.31) to give the shear stress (τ) as</p> $\begin{aligned} \tau &= \frac{T}{2 A_m t_1} = \frac{6,000 \text{ N} \cdot \text{m}}{2(0.02 \text{ m}^2)(0.006 \text{ m})} \\ &= \frac{6,000 \text{ N} \cdot \text{m}}{(0.00024 \text{ m}^3)} = 25,000,000 \text{ N/m}^2 \\ &= 25 \text{ MPa} \end{aligned}$ <p><i>Step 3.</i> Calculate the polar moment of inertia (J) for the rectangular tube using Eq. (1.34).</p> $\begin{aligned} J &= \frac{2b^2 h^2 t_1 t_2}{bt_1 + ht_2} \\ &= \frac{2(0.1 \text{ m})^2 (0.2 \text{ m})^2 (0.006 \text{ m})(0.012 \text{ m})}{(0.1 \text{ m})(0.006 \text{ m}) + (0.2 \text{ m})(0.012 \text{ m})} \\ &= \frac{5.76 \times 10^{-8} \text{ m}^6}{0.003 \text{ m}^2} = 1.92 \times 10^{-5} \text{ m}^4 \end{aligned}$ <p><i>Step 4.</i> Substitute the torque (T), length (L), shear modulus of elasticity (G), and the polar moment of inertia (J) just calculated, in Eq. (1.32) to find the angle of twist (ϕ).</p> $\begin{aligned} \phi &= \frac{TL}{GJ} \\ &= \frac{(6,000 \text{ N} \cdot \text{m})(0.8 \text{ m})}{(80.8 \times 10^9 \text{ N/m}^2)(1.92 \times 10^{-5} \text{ m}^4)} \\ &= \frac{4,800 \text{ N} \cdot \text{m}^2}{1,551,360 \text{ N} \cdot \text{m}^2} \\ &= 0.0031 \text{ rad} \end{aligned}$

1.5 BENDING

Figure 1.23 shows a simply-supported beam with a concentrated force (F) located at its midpoint. This force produces both a bending moment distribution and a shear force distribution in the beam. At any location along the length (L) of the beam, the bending moment produces a normal stress (σ) and the shear force produces a shear stress (τ).

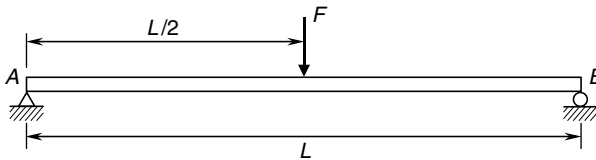

FIGURE 1.23 Bending.

It is assumed that the bending moment and shear force is known. If not, bending moment and shear force distributions, as well as deflection equations, are provided in Chap. 2 for a variety of beam configurations and loadings. Note that beam deflections represent the *deformation* caused by bending. Also, there is no explicit expression for strain owing to bending, because again, there are so many possible variations in beam configuration and loading.

Stress Owing to Bending Moment. Once the bending moment (M) has been determined at a particular point along a beam, then the normal stress distribution (σ) can be determined from Eq. (1.35) as

$$\sigma = \frac{My}{I} \quad (1.35)$$

where (y) is distance from the neutral axis (centroid) to the point of interest and (I) is area moment of inertia about an axis passing through the neutral axis.

The distribution given by Eq. (1.35) is linear as shown in Fig. 1.24, with the maximum normal stress (σ_{\max}) occurring at the top of the beam, the minimum normal stress (σ_{\min}) occurring at the bottom of the beam, and zero at the neutral axis ($y = 0$).

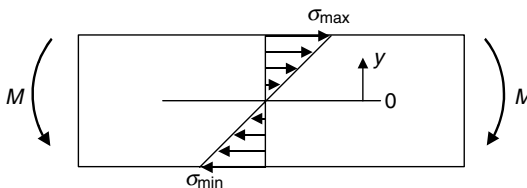

FIGURE 1.24 Bending stress distribution.

For the directions of the bending moments (M) shown in Fig. 1.24, which by standard convention are considered negative, (σ_{\max}) is a positive tensile stress and (σ_{\min}) is a negative compressive stress. Also, the term *neutral axis* gets its name from the fact that the bending stress is zero, or *neutral*, when the distance (y) is zero.

Some references place a minus sign ($-$) in front of the term on the right hand side of Eq. (1.35) so that when the bending moment (M) is positive, a compressive stress

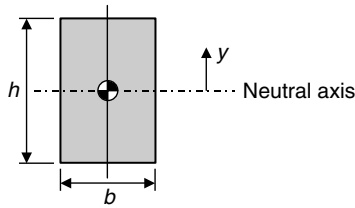

FIGURE 1.25 Rectangular beam.

automatically results for positive values of the distance (y). This can be confusing, so this minus sign is not used in this book. Besides, it is usually obvious in most problems, where the bending stress is tensile and where it is compressive.

The most common beam cross section is rectangular, as shown in Fig. 1.25.

For the rectangular beam of Fig. 1.25, the maximum value of the distance (y) is half of the height (h). The moment of inertia (I) for this rectangular cross section about the neutral axis that passes through the centroid of the area, is given by Eq. (1.36) as

$$I = \frac{1}{12} bh^3 \quad (1.36)$$

U.S. Customary	SI/Metric
<p>Example 1. Determine the maximum bending stress (σ_{\max}) in a beam with a rectangular cross section, where</p> <p>$M = 20,000 \text{ ft} \cdot \text{lb} = 240,000 \text{ in} \cdot \text{lb}$ $b = 2 \text{ in}$ $h = 6 \text{ in} = 2y_{\max}$</p> <p>solution</p> <p><i>Step 1.</i> Calculate the moment of inertia (I) of the rectangular cross section using Eq. (1.36).</p> $I = \frac{1}{12} bh^3 = \frac{1}{12} (2 \text{ in}) (6 \text{ in})^3$ $= 36 \text{ in}^4$ <p><i>Step 2.</i> Substitute the bending moment (M), the maximum distance (y_{\max}), and the moment of inertia (I) just found, in Eq. (1.35) to determine the maximum bending stress (σ_{\max}).</p> $\sigma_{\max} = \frac{My_{\max}}{I} = \frac{M(h/2)}{I}$ $= \frac{(240,000 \text{ in} \cdot \text{lb}) (3 \text{ in})}{36 \text{ in}^4}$ $= 20,000 \text{ lb/in}^2 = 20 \text{ ksi}$	<p>Example 1. Determine the maximum bending stress (σ_{\max}) in a beam with a rectangular cross section, where</p> <p>$M = 30,000 \text{ N} \cdot \text{m}$ $b = 5 \text{ cm} = 0.05 \text{ m}$ $h = 15 \text{ cm} = 0.15 \text{ m} = 2y_{\max}$</p> <p>solution</p> <p><i>Step 1.</i> Calculate the moment of inertia (I) of the rectangular cross section using Eq. (1.36).</p> $I = \frac{1}{12} bh^3 = \frac{1}{12} (0.05 \text{ m}) (0.15 \text{ m})^3$ $= 0.000014 \text{ m}^4$ <p><i>Step 2.</i> Substitute the bending moment (M), the maximum distance (y_{\max}), and the moment of inertia (I) just found, in Eq. (1.35) to determine the maximum bending stress (σ_{\max}).</p> $\sigma_{\max} = \frac{My_{\max}}{I} = \frac{M(h/2)}{I}$ $= \frac{(30,000 \text{ N} \cdot \text{m}) (0.075 \text{ m})}{0.000014 \text{ m}^4}$ $= 160,000,000 \text{ N/m}^2 = 160 \text{ MPa}$

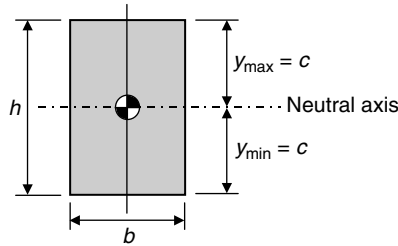

FIGURE 1.26 Limiting values of the distance (y).

The most difficult fact about calculating the bending stress (σ) using Eq. (1.35) is determining the bending moment (M). This is why Chap. 2 is devoted entirely to finding the bending moment and shear force distributions for the most common beam configurations and loadings.

Before moving on to shear stress owing to bending, there is a quantity associated with the limiting values of the distance (y) in Eq. (1.35). If the maximum value (y_{\max}) is considered positive upward from the neutral axis, then the minimum value (y_{\min}) is considered negative downward from the neutral axis. For the rectangular cross section of Fig. 1.25, these two limiting values are equal in magnitude but opposite in sign. Figure 1.26 shows these limiting values.

For other cross-sectional areas, these limiting values may be different. In either case, if the distance (y) in Eq. (1.35) is moved from the numerator to the denominator, then a quantity called the section modulus (S) is defined. This algebraic process is shown in Eq. (1.37).

$$\sigma_{\max} = \frac{My_{\max}}{I} = \frac{M}{I/y_{\max}} = \frac{M}{S_{\max}} \quad \text{or} \quad \sigma_{\min} = \frac{My_{\min}}{I} = \frac{M}{I/y_{\min}} = \frac{M}{S_{\min}} \quad (1.37)$$

As mentioned earlier, a rectangular cross section has equal maximum and minimum values of the distance (y), only their signs are opposite, and which are typically labeled (c). The section modulus for a rectangular cross section becomes that given in Eq. (1.38). The units of section modulus are length cubed, that is, in^3 or m^3 .

$$S = \frac{I}{y_{\max}} = \frac{I}{y_{\min}} = \frac{I}{c} \quad (1.38)$$

U.S. Customary	SI/Metric
<p>Example 2. Calculate the section modulus (S) for the beam with the rectangular cross section in Example 1, where</p> <p>$I = 36 \text{ in}^4$ (from Example 1) $h = 6 \text{ in} = 2c$</p> <p>solution <i>Step 1.</i> Substituting the moment of inertia (I) and the maximum distance (c) into Eq. (1.38) gives</p> $S = \frac{I}{y_{\max}} = \frac{I}{y_{\min}} = \frac{I}{c}$ $= \frac{36 \text{ in}^4}{3 \text{ in}} = 12 \text{ in}^3$	<p>Example 2. Calculate the section modulus (S) for the beam with the rectangular cross section in Example 1, where</p> <p>$I = 0.000014 \text{ m}^4$ (from Example 1) $h = 15 \text{ cm} = 0.15 \text{ m} = 2c$</p> <p>solution <i>Step 1.</i> Substituting the moment of inertia (I) and the maximum distance (c) into Eq. (1.38) gives</p> $S = \frac{I}{y_{\max}} = \frac{I}{y_{\min}} = \frac{I}{c}$ $= \frac{0.000014 \text{ m}^4}{0.075 \text{ m}} = 0.00019 \text{ m}^3$

Shear Stress Owing to Bending. Once the shear force (V) has been determined at a particular point along a beam, the shear stress distribution (τ) can be determined from Eq. (1.39) as

$$\tau = \frac{VQ}{Ib} \quad (1.39)$$

where $Q = A\bar{y}$, first moment of area (A)

A = area out beyond point of interest, specified by distance (y)

\bar{y} = distance to centroid of area (A) defined above

I = area moment of inertia about an axis passing through neutral axis

b = width of beam at point of interest

The distribution given by Eq. (1.39) is quadratic (meaning second order) in the distance (y) as shown in Fig. 1.27, with the maximum shear stress (τ_{\max}) occurring at neutral axis ($y = 0$), and the minimum shear stress (τ_{\min}), which is zero, occurring at the top and bottom of the beam.

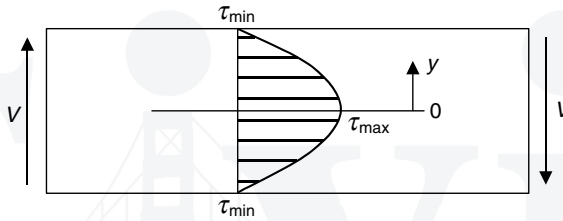

FIGURE 1.27 Shear stress distribution.

The directions of the two shear forces (V) shown in Fig. 1.27 are positive, based on accepted sign convention, even though the one on the left is upward and the one on the right is downward. The direction of the shear stress (τ) over the cross section is always in the same direction as the shear force, that is up on the left and down on the right.

As stated earlier in this section, the most common beam cross section is rectangular, as shown in Fig. 1.28.

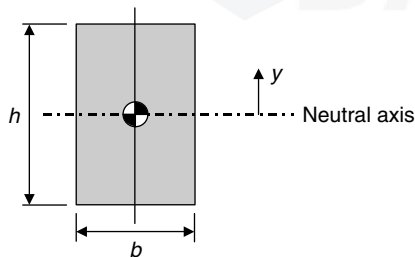

FIGURE 1.28 Rectangular beam.

The moment of inertia (I) for this rectangular cross section about the neutral axis that passes through the centroid of the area, is given by Eq. (1.40),

$$I = \frac{1}{12} bh^3 \quad (1.40)$$

and the width (b) of the beam is constant.

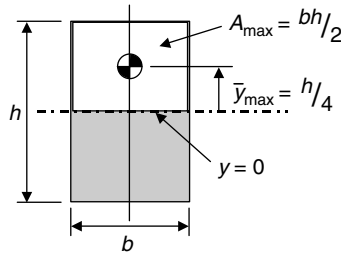

FIGURE 1.29 Maximum first moment.

Based on the definition of the first moment (Q), the maximum value (Q_{\max}) for a rectangle is given by Eq. (1.41) as

$$Q_{\max} = A_{\max} \bar{y}_{\max} = \left(\frac{bh}{2}\right)\left(\frac{h}{4}\right) = \frac{1}{8}bh^2 \quad (1.41)$$

and shown in Fig. 1.29.

U.S. Customary	SI/Metric
<p>Example 3. Determine the maximum shear stress (τ_{\max}) for the beam geometry of Example 1, and where</p> <p>$V = 2,000$ lb $b = 2$ in $h = 6$ in = $2y_{\max}$</p> <p>solution</p> <p><i>Step 1.</i> Calculate the maximum first moment (Q_{\max}) for the rectangular cross section using Eq. (1.41).</p> $Q_{\max} = \frac{1}{8}bh^2 = \frac{1}{8}(2\text{ in})(6\text{ in})^2$ $= 9\text{ in}^3$ <p><i>Step 2.</i> Use Eq. (1.40) to calculate the moment of inertia (I).</p> $I = \frac{1}{12}bh^3 = \frac{1}{12}(2\text{ in})(6\text{ in})^3$ $= 36\text{ in}^4$ <p><i>Step 3.</i> Substitute the shear force (V), the maximum first moment (Q_{\max}) and the moment of inertia (I) just calculated, and the width (b) into Eq. (1.39) to determine the maximum shear stress (τ_{\max}).</p>	<p>Example 3. Determine the maximum shear stress (τ_{\max}) for the beam geometry of Example 1, and where</p> <p>$V = 9,000$ N $b = 5$ cm = 0.05 m $h = 15$ cm = 0.15 m = $2y_{\max}$</p> <p>solution</p> <p><i>Step 1.</i> Calculate the maximum first moment (Q_{\max}) for the rectangular cross section using Eq. (1.41).</p> $Q_{\max} = \frac{1}{8}bh^2 = \frac{1}{8}(0.15\text{ m})^2$ $= 0.00014\text{ m}^3$ <p><i>Step 2.</i> Use Eq. (1.40) to calculate the moment of inertia (I).</p> $I = \frac{1}{12}bh^3 = \frac{1}{12}(0.05\text{ m})(0.15\text{ m})^3$ $= 0.000014\text{ m}^4$ <p><i>Step 3.</i> Substitute the shear force (V), the maximum first moment (Q_{\max}) and the moment of inertia (I) just calculated, and the width (b) into Eq. (1.39) to determine the maximum shear stress (τ_{\max}).</p>

U.S. Customary	SI/Metric
$\begin{aligned}\tau_{\max} &= \frac{VQ_{\max}}{Ib} = \frac{(2,000 \text{ lb})(9 \text{ in}^3)}{(36 \text{ in}^4)(2 \text{ in})} \\ &= \frac{18,000 \text{ lb} \cdot \text{in}^3}{72 \text{ in}^5} \\ &= 250 \text{ lb/in}^2 = 250 \text{ psi}\end{aligned}$ <p>Example 4. Determine the shear stress (τ) at a distance ($y = h/4$) for the beam geometry of Example 3, and where</p> <p>$V = 2,000 \text{ lb}$ $b = 2 \text{ in}$ $h = 6 \text{ in}$ $I = 36 \text{ in}^4$ (previously calculated)</p> <p>solution</p> <p><i>Step 1.</i> Calculate the first moment (Q) for the rectangular cross section at a distance ($y = h/4$) using Eq. (1.42).</p> $\begin{aligned}Q &= \frac{3}{32}bh^2 = \frac{3}{32}(2 \text{ in})(6 \text{ in})^2 \\ &= 6.75 \text{ in}^3\end{aligned}$ <p><i>Step 2.</i> Substitute the shear force (V), first moment (Q) from Step 1, moment of inertia (I), and the width (b) into Eq. (1.39) to determine the shear stress (τ).</p> $\begin{aligned}\tau &= \frac{VQ}{Ib} = \frac{(2,000 \text{ lb})(6.75 \text{ in}^3)}{(36 \text{ in}^4)(2 \text{ in})} \\ &= \frac{13,500 \text{ lb} \cdot \text{in}^3}{72 \text{ in}^5} \\ &= 187.5 \text{ lb/in}^2 = 188 \text{ psi}\end{aligned}$	$\begin{aligned}\tau_{\max} &= \frac{VQ_{\max}}{Ib} = \frac{(9,000 \text{ N})(0.00014 \text{ m}^3)}{(0.000014 \text{ m}^4)(0.05 \text{ m})} \\ &= \frac{1.26 \text{ N} \cdot \text{m}^3}{0.0000007 \text{ m}^5} \\ &= 1,800,000 \text{ N/m}^2 = 1.8 \text{ MPa}\end{aligned}$ <p>Example 4. Determine the shear stress (τ) at a distance ($y = h/4$) for the beam geometry of Example 3, and where</p> <p>$V = 9,000 \text{ N}$ $b = 5 \text{ cm} = 0.05 \text{ m}$ $h = 15 \text{ cm} = 0.15 \text{ m}$ $I = 0.000014 \text{ m}^4$ (previously calculated)</p> <p>solution</p> <p><i>Step 1.</i> Calculate the first moment (Q) for the rectangular cross section at a distance ($y = h/4$) using Eq. (1.42).</p> $\begin{aligned}Q &= \frac{3}{32}bh^2 = \frac{3}{32}(0.05 \text{ m})(0.15 \text{ m})^2 \\ &= 0.000105 \text{ m}^3\end{aligned}$ <p><i>Step 2.</i> Substitute the shear force (V), first moment (Q) from Step 1, moment of inertia (I), and the width (b) into Eq. (1.39) to determine the shear stress (τ).</p> $\begin{aligned}\tau &= \frac{VQ}{Ib} = \frac{(9,000 \text{ N})(0.000105 \text{ m}^3)}{(0.000014 \text{ m}^4)(0.05 \text{ m})} \\ &= \frac{0.945 \text{ N} \cdot \text{m}^3}{0.0000007 \text{ m}^5} \\ &= 1,350,000 \text{ N/m}^2 = 1.35 \text{ MPa}\end{aligned}$

Notice that the maximum normal stress (σ_{\max}) found in Example 1 is 80 to 90 times greater than the maximum shear stress (τ_{\max}) found in Example 3. This is typically the case when the values for the bending moment (M) and the shear force (V) are from the middle of a beam. However, near a support the maximum shear stress will be greater than the maximum normal stress, which may in fact be zero at a support.

As stated earlier, the maximum shear stress (τ_{\max}) occurs at a distance ($y = 0$) that is the neutral axis, and the shear stress is zero at the top and bottom of the beam that is at a distance ($y = h/2$). Suppose the shear stress (τ) at an intermediate position was desired, say at a distance ($y = h/4$). The only difference is the first moment (Q) that can be found using the information shown in Fig. 1.30.

Based on the definition of the first moment (Q), its value is given by Eq. (1.42)

$$Q = A\bar{y} = \left(\frac{bh}{4}\right)\left(\frac{3h}{8}\right) = \frac{3}{32}bh^2 \quad (1.42)$$

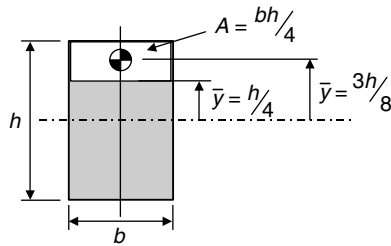

FIGURE 1.30 Intermediate first moment.

Direct Shear Versus Shear Owing to Bending. In Sec. 1.1.2 the rivet holding together the two overlapping bars shown in Fig. 1.31 was said to be under direct shear loading.

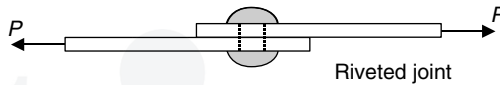

FIGURE 1.31 Direct shear loading.

It was found that if the rivet is cut in half at the overlap to expose the cross-sectional area (A) of the rivet, then Fig. 1.32 shows the resulting free-body-diagram.



FIGURE 1.32 Free-body-diagram.

From equilibrium, the shear force (V) is equal to the applied force (P), and the shear stress (τ) is given by Eq. (1.43) as

$$\tau = \frac{V}{A} = \frac{P}{A_{\text{rivet}}} \quad (1.43)$$

Consider the overlapping joint shown in Fig. 1.33, where again the rivet is under direct shear loading.

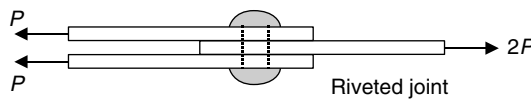

FIGURE 1.33 Direct shear loading.

To expose the cross sections of the rivet, the top and bottom plates need to be removed to form the free-body-diagram shown in Fig. 1.34.

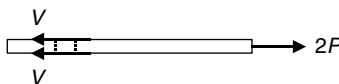

FIGURE 1.34 Direct shear loading.

From equilibrium, the two shear forces (V) are equal to the applied force ($2P$), so a single shear force (V) equals a single applied force (P) and the shear stress (τ) is given by Eq. (1.44) as

$$\tau = \frac{V}{A} = \frac{P}{A_{\text{rivet}}} \quad (1.44)$$

[Note that the applied force (P) in Eq. (1.44) is twice the applied force (P) in Eq. (1.43).]

Consider a modification of the overlapping joint in Fig. 1.33, where now there are gaps between the plates as shown in Fig. 1.35, and the rivet is no longer under direct shear loading but shear owing to bending. This means the rivet is acting like a beam and so the shear stress (τ) is given by Eq. (1.45).

$$\tau = \frac{VQ}{Ib} \quad (1.45)$$

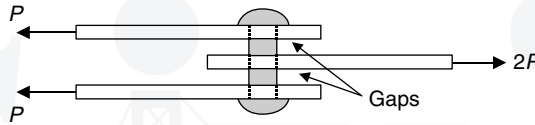

FIGURE 1.35 Shear owing to bending.

Rivets, as well as pins and bolts, have circular cross sections like that shown in Fig. 1.36.

Using the definition of the first moment, and the nomenclature of Fig. 1.35, the maximum first moment (Q_{max}) for a circular cross section is given by Eq. (1.46).

$$Q_{\text{max}} = A_{\text{max}} \bar{y}_{\text{max}} = \left(\frac{\pi R^2}{2} \right) \left(\frac{4R}{3\pi} \right) = \frac{2}{3} R^3 \quad (1.46)$$

The area moment of inertia (I) for a circular cross section about the neutral axis that passes through the centroid of the area, is given by Eq. (1.47),

$$I = \frac{1}{4} \pi R^4 \quad (1.47)$$

and the maximum width (b_{max}) of a circular cross-section beam is the diameter, or ($2R$).

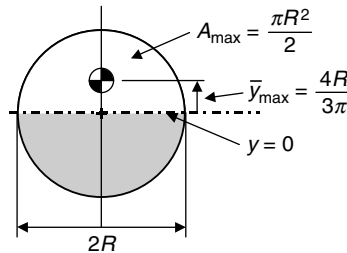

FIGURE 1.36 Maximum first moment.

Substituting the maximum first moment (Q_{\max}) from Eq. (1.46), the area moment of inertia (I) from Eq. (1.47), and the maximum width (b_{\max}) equal to $(2R)$ into the expression for shear stress (τ) owing to bending in Eq. (1.45) gives

$$\tau_{\max} = \frac{VQ_{\max}}{Ib_{\max}} = \frac{V\left(\frac{2}{3}R^3\right)}{\left(\frac{1}{4}\pi R^4\right)(2R)} = \frac{4}{3} \frac{V}{\pi R^2} = \frac{4}{3} \frac{V}{A} \quad (1.48)$$

The importance of Eq. (1.48) is that it shows the maximum shear stress owing to bending is greater by one third (33 percent) of the maximum shear stress owing to direct shear loading. This is a nontrivial difference and great care should be taken if a rivet, pin, or bolt is in bending rather than in direct shear.



CHAPTER 2

BEAMS: REACTIONS, SHEAR FORCE AND BENDING MOMENT DISTRIBUTIONS, AND DEFLECTIONS

2.1 INTRODUCTION

Virtually all machines, especially complex ones, have one or more elements acting as beams. Unlike axial loading that is either tensile or compressive, or torsional loading that is either clockwise or counterclockwise, there is what appears to be an infinite number of possible loadings associated with beams. The number is obviously not infinite; but with the possible types of loads that a beam can support (e.g., forces, couples, or distributed loads), the possible types of beam supports (pin, roller, or cantilever), and the possible combinations of these loads and supports, the number of unique beam configurations can easily seem infinite.

The beam and loading configurations presented in this book cover the important ones that mechanical engineers are likely to encounter. These configurations are divided into two main categories: simply-supported and cantilevered, with simply-supported category divided into three subcategories. In all, there are 15 beam and loading configurations. For each beam configuration, there are, on average, five example calculations presented to include finding support reactions, shear force and bending moments, and deflections. This means there are over 75 such examples provided.

Before getting started with the first of these 15 configurations, there are three graphical symbols used for the three types of beam supports: pin, roller, and cantilever. The beam in Fig. 2.1, called a *simply-supported* beam, shows two of these symbols, a pin support at the left end and a roller support at the right end.

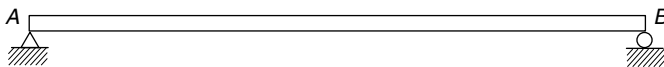

FIGURE 2.1 Simply-supported beam.

The beam in Fig. 2.2, called a *cantilevered* beam, shows the third symbol, a cantilever support at the left end, with the right end free. These are merely symbols; graphical models of real beams supports.

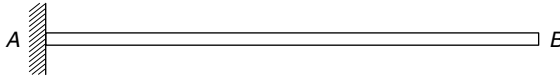

FIGURE 2.2 Cantilevered beam.

The first idealized symbol, the pin support shown at point A in Fig. 2.3(a), looks like a knife edge, but it is not. It represents the ability of this type of support to restrict motion left and right, as well as up and down. The graphical symbol shown in Fig. 2.3(b) shows why this is called a pin support, in that for a real support of this type there is physically a pin connecting the beam to some type of clevis structure attached to the foundation. For the beams that will be presented, this level of detail is unnecessary. Foundations, depicted by a straight line and hash marks, are always assumed to be rigid.

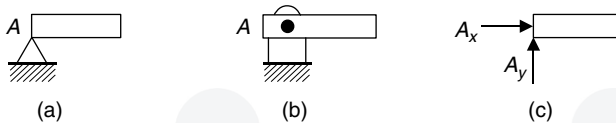

FIGURE 2.3 Pin support symbols and reactions.

Whenever there is a restriction in motion, there must be a force present to cause this restriction. As a pin support restricts motion in two directions, there must be two forces present, called reaction forces, shown as A_x and A_y in Fig. 2.3(c). The magnitude and direction of these two forces will depend on the loading configuration, so until they are determined, these forces are usually shown in positive directions.

The second idealized symbol, the roller support shown at point B in Fig. 2.4(a), looks like the beam is just resting on the roller, but it is not. It represents the ability of this type of support to only restrict motion up and down, meaning perpendicular to the foundation. The graphical symbol in Fig. 2.4(b) shows a more detailed drawing of a roller, similar to the one shown in Fig. 2.3(b) for the pin support. In reality, a roller physically has a pin connecting the beam to some clevis structure that in turn rests on the foundation. Again, for the beams that will be presented, this level of detail is unnecessary.

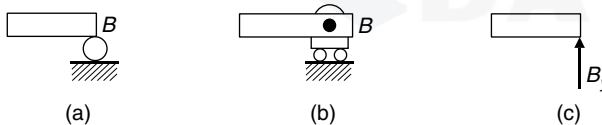

FIGURE 2.4 Roller support symbols and reaction.

Because a roller support restricts motion in only one direction, perpendicular to the foundation, there must be one reaction force present, shown as B_y in Fig. 2.4(c). The magnitude and direction of this force will depend on the loading configuration, so again, until it is determined, this force is shown in the positive direction.

For the third idealized symbol, the cantilever support shown at point A in Fig. 2.5(a) looks like the beam is just stuck to the side of the vertical wall, but it is not. It represents the ability of this type of support, like a pin support, to restrict motion left and right, and up and down, but also to restrict rotation, clockwise or counterclockwise, of the beam at the support. The graphical symbol in Fig. 2.5(b) shows a more detailed drawing of a cantilever support; however, as already stated, this level of detail is unnecessary for the beams that will be presented.

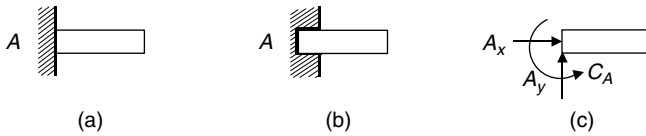

FIGURE 2.5 Cantilever support symbols and reactions.

Because a cantilever support restricts motion in two directions, as well as rotation at the support, the reactions must include two forces and a couple. These are shown as forces A_x and A_y , and couple C_A , in Fig. 2.5(c). The magnitude and direction of these forces and couple will depend on the loading configuration, so again, until determined, they are shown in positive directions, where counterclockwise rotation is considered positive.

Remember, the symbols used by engineers to represent real supports are idealized, mathematical models, and were never intended to depict actual structures. However, the results obtained from these models have proven to be very accurate representations of real situations, and in fact, tend to provide a built-in factor of safety to your design.

2.2 SIMPLY-SUPPORTED BEAMS

As stated earlier, simply-supported beams, like the *end-supported* beam shown in Fig. 2.6, have a pin-type support at one end and a roller-type support at the other.



FIGURE 2.6 Simply-supported beam.

The pin at A restricts motion left and right, as well as up and down, whereas the roller at B only restricts motion up and down. (Actually, for the orientation shown, the roller can only produce a reaction force upward, so, if a particular loading requires a downward reaction, the roller would need to be shown on the top side of the beam.)

There are two common variations on the simply-supported beam: the *single overhanging* beam shown in Fig. 2.7, and the *double overhanging* beam shown in Fig. 2.8.

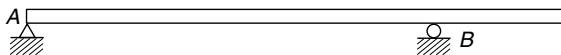

FIGURE 2.7 Single overhanging beam.

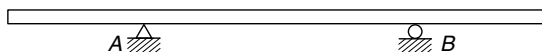

FIGURE 2.8 Double overhanging beam.

Examples involving several different types of loadings will be presented for each of these three simply-supported beams, to include concentrated forces, concentrated couples, and distributed loads. Calculations for the reactions, shear force and bending moment distributions, and deflections will be provided in both the U.S. Customary and SI or metric units.

2.2.1 Concentrated Force at Midpoint

The simply-supported beam in Fig. 2.9 has a concentrated force (F) acting vertically downward at its midpoint. The distance between the supports is labeled (L), so the force (F) is located half the distance ($L/2$) from each end support.

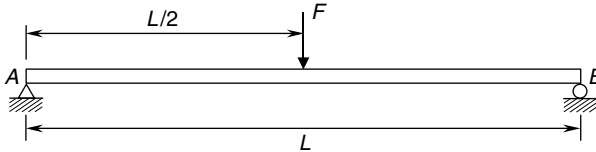

FIGURE 2.9 Concentrated force at midpoint.

Reactions. The reactions at the end supports are shown in Fig. 2.10—the balanced free-body-diagram. Notice that the force (F) is split evenly between the vertical reactions (A_y and B_y), and because the force (F) is acting straight down, the horizontal reaction (A_x) is zero. If the force (F) had a horizontal component, either left or right, then the horizontal reaction (A_x) would be equal, but opposite in direction, to this horizontal component.

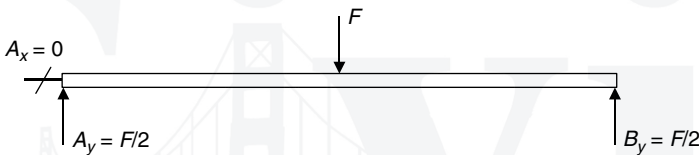

FIGURE 2.10 Free-body-diagram.

U.S. Customary	SI/Metric
<p>Example 1. Determine the reactions at the ends of a simply-supported beam of length (L) with a concentrated force (F) acting at its midpoint, where</p> $F = 12 \text{ kip} = 12,000 \text{ lb}$ $L = 6 \text{ ft}$ <p>solution</p> <p><i>Step 1.</i> From Fig. 2.10, calculate the pin reactions (A_x and A_y) at the left end of the beam. As the force (F) is vertical,</p> $A_x = 0$ <p>and as the force (F) is at the midpoint,</p> $A_y = \frac{F}{2} = \frac{12,000 \text{ lb}}{2} = 6,000 \text{ lb}$ <p><i>Step 2.</i> From Fig. 2.10, calculate the roller reaction (B_y) at the right end of the beam. As the force (F) is at the midpoint,</p> $B_y = \frac{F}{2} = \frac{12,000 \text{ lb}}{2} = 6,000 \text{ lb}$	<p>Example 1. Determine the reactions at the ends of a simply-supported beam of length (L) with a concentrated force (F) acting at its midpoint, where</p> $F = 55 \text{ kN} = 55,000 \text{ N}$ $L = 2 \text{ m}$ <p>solution</p> <p><i>Step 1.</i> From Fig. 2.10 calculate the pin reactions (A_x and A_y) at the left end of the beam. As the force (F) is vertical,</p> $A_x = 0$ <p>and as the force (F) is at the midpoint,</p> $A_y = \frac{F}{2} = \frac{55,000 \text{ N}}{2} = 27,500 \text{ N}$ <p><i>Step 2.</i> From Fig. 2.10, calculate the roller reaction (B_y) at the right end of the beam. As the force (F) is at the midpoint,</p> $B_y = \frac{F}{2} = \frac{55,000 \text{ N}}{2} = 27,500 \text{ N}$

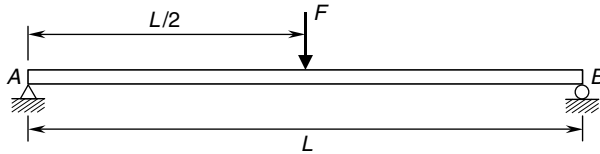

FIGURE 2.11 Concentrated force at midpoint.

Shear Force and Bending Moment Distributions. For the simply-supported beam with a concentrated force (F) at its midpoint, shown in Fig. 2.11 that has the balanced free-body diagram shown in Fig. 2.12, the shear force (V) distribution is shown in Fig. 2.13.

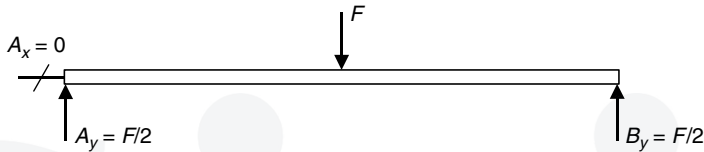

FIGURE 2.12 Free-body diagram.

Note that the shear force (V) is a positive ($F/2$) from the left end of the beam to the midpoint, and a negative ($F/2$) from the midpoint to the right end of the beam. So there is a discontinuity in the shear force at the midpoint of the beam, of magnitude (F), where the concentrated force is applied. The maximum shear force (V_{\max}) is therefore

$$V_{\max} = \frac{F}{2} \quad (2.1)$$

The bending moment distribution is given by Eq. (2.2a) for all values of the distance (x) from the left end of the beam to the midpoint and Eq. (2.2b) from the midpoint to the right end of the beam. (Always measure the distance (x) from the left end of any beam.)

$$M = \frac{F}{2} x \quad 0 \leq x \leq \frac{L}{2} \quad (2.2a)$$

$$M = \frac{F}{2} (L - x) \quad \frac{L}{2} \leq x \leq L \quad (2.2b)$$

The bending moment (M) distribution is shown in Fig. 2.14.

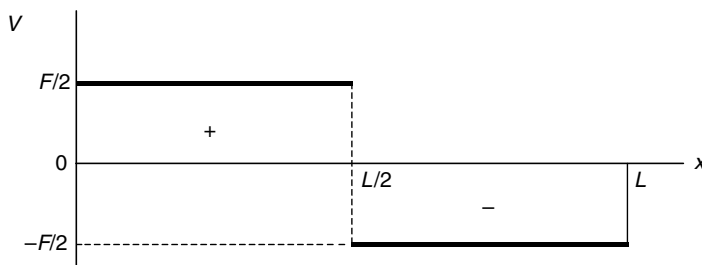

FIGURE 2.13 Shear force diagram.

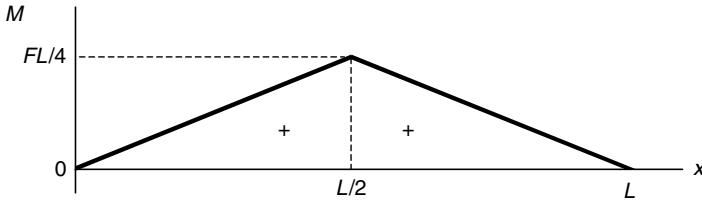

FIGURE 2.14 Bending moment diagram.

Note that the bending moment (M) is zero at both ends, and increases linearly to a maximum at the midpoint ($L/2$). From the midpoint, the bending moment decreases linearly back to zero. The maximum bending moment (M_{\max}) occurs at the midpoint of the beam and is given by Eq. (2.3).

$$M_{\max} = \frac{FL}{4} \quad (2.3)$$

U.S. Customary	SI/Metric
<p>Example 2. Calculate the shear force (V) and bending moment (M) for a simply-supported beam with a concentrated force (F) at its midpoint a distance ($L/4$) from the right end of the beam, where</p> $F = 12 \text{ kip} = 12,000 \text{ lb}$ $L = 6 \text{ ft}$ <p>solution</p> <p><i>Step 1.</i> Establish the distance (x) from the left end of the beam, where</p> $x = L - \frac{L}{4} \text{ (distance from right end)} = \frac{3L}{4}$ $= \frac{3(6 \text{ ft})}{4} = \frac{18 \text{ ft}}{4} = 4.5 \text{ ft}$ <p><i>Step 2.</i> Determine the shear force (V) from Fig. 2.13 as</p> $V = -\frac{F}{2} = -\frac{12,000 \text{ lb}}{2} = -6,000 \text{ lb}$ <p><i>Step 3.</i> Determine the bending moment (M) from Eq. (2.2b).</p> $M = \frac{F}{2}(L - x) = \frac{12,000 \text{ lb}}{2}(6 \text{ ft} - 4.5 \text{ ft})$ $= (6,000 \text{ lb})(1.5 \text{ ft}) = 9,000 \text{ ft} \cdot \text{lb}$ <p>Example 3. Calculate and locate the maximum shear force (V_{\max}) and the maximum bending moment (M_{\max}) for the beam of Examples 1 and 2, where</p> $F = 12 \text{ kip} = 12,000 \text{ lb}$ $L = 6 \text{ ft}$	<p>Example 2. Calculate the shear force (V) and bending moment (M) for a simply-supported beam with a concentrated force (F) at its midpoint a distance ($L/4$) from the right end of the beam, where</p> $F = 55 \text{ kN} = 55,000 \text{ N}$ $L = 2 \text{ m}$ <p>solution</p> <p><i>Step 1.</i> Establish the distance (x) from the left end of the beam, where</p> $x = L - \frac{L}{4} \text{ (distance from right end)} = \frac{3L}{4}$ $= \frac{3(2 \text{ m})}{4} = \frac{6 \text{ m}}{4} = 1.5 \text{ m}$ <p><i>Step 2.</i> Determine the shear force (V) from Fig. 2.13 as</p> $V = -\frac{F}{2} = -\frac{55,000 \text{ N}}{2} = -27,500 \text{ N}$ <p><i>Step 3.</i> Determine the bending moment (M) from Eq. (2.2b).</p> $M = \frac{F}{2}(L - x) = \frac{55,000 \text{ N}}{2}(2 \text{ m} - 1.5 \text{ m})$ $= (27,500 \text{ N})(0.5 \text{ m}) = 13,750 \text{ N} \cdot \text{m}$ <p>Example 3. Calculate and locate the maximum shear force (V_{\max}) and the maximum bending moment (M_{\max}) for the beam of Examples 1 and 2, where</p> $F = 55 \text{ kN} = 55,000 \text{ N}$ $L = 2 \text{ m}$

U.S. Customary	SI/Metric
<p>solution</p> <p><i>Step 1.</i> Calculate the maximum shear force (V_{\max}) from Eq. (2.1) as</p> $V_{\max} = \frac{F}{2} = \frac{12,000 \text{ lb}}{2} = 6,000 \text{ lb}$ <p><i>Step 2.</i> As shown in Fig. 2.13, this maximum shear force (V_{\max}) of 6,000 lb does not have a specific location.</p> <p><i>Step 3.</i> Calculate the maximum bending moment (M_{\max}) from Eq. (2.3) as</p> $M_{\max} = \frac{FL}{4} = \frac{(12,000 \text{ lb})(6 \text{ ft})}{4}$ $= \frac{72,000 \text{ ft} \cdot \text{lb}}{4} = 18,000 \text{ ft} \cdot \text{lb}$ <p><i>Step 4.</i> Figure 2.14 shows that this maximum bending moment (M_{\max}) of 18,000 ft · lb is located at the midpoint of the beam.</p>	<p>solution</p> <p><i>Step 1.</i> Calculate the maximum shear force (V_{\max}) from Eq. (2.1) as</p> $V_{\max} = \frac{F}{2} = \frac{55,000 \text{ N}}{2} = 27,500 \text{ N}$ <p><i>Step 2.</i> As shown in Fig. 2.13, this maximum shear force (V_{\max}) of 27,500 N does not have a specific location.</p> <p><i>Step 3.</i> Calculate the maximum bending moment (M_{\max}) from Eq. (2.3) as</p> $M_{\max} = \frac{FL}{4} = \frac{(55,000 \text{ N})(2 \text{ m})}{4}$ $= \frac{110,000 \text{ N} \cdot \text{m}}{4} = 27,500 \text{ N} \cdot \text{m}$ <p><i>Step 4.</i> As shown in Fig. 2.14, this maximum bending moment (M_{\max}) of 27,500 N · m is located at the midpoint of the beam.</p>

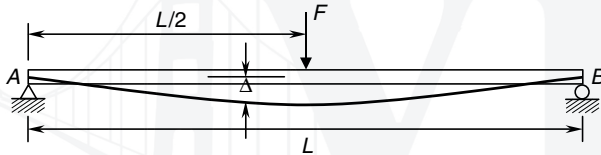

FIGURE 2.15 Beam deflection diagram.

Deflection. For this loading configuration, the deflection (Δ) along the beam is shown in Fig. 2.15, and given by Eq. (2.4) for values of distance (x) from the left end of the beam,

$$\Delta = \frac{Fx}{48EI} (3L^2 - 4x^2) \quad 0 \leq x \leq \frac{L}{2} \quad (2.4)$$

where Δ = deflection of beam

F = applied force at midpoint of beam

x = distance from left end of beam

L = length of beam

E = modulus of elasticity of beam material

I = area moment of inertia of cross-sectional area about axis through centroid

Note that the distance (x) in Eq. (2.4) must be between 0 and half the length of the beam ($L/2$). As the deflection is symmetrical about the midpoint of the beam, values of the distance (x) greater than the length ($L/2$) have no meaning in this equation.

The maximum deflection (Δ_{\max}) caused by this loading configuration is given by Eq. (2.5),

$$\Delta_{\max} = \frac{FL^3}{48EI} \quad \text{at } x = \frac{L}{2} \quad (2.5)$$

located at the midpoint ($L/2$) of the beam directly under the concentrated force (F). As will be shown in the following examples, the value for the deflection (Δ) at any location along the beam for this loading configuration will be downward. However, although many loading configurations produce deflections that are always downward, still others have deflections that are always upward, and still others where the deflection is both upward and downward, depending on the location along the length of the beam.

U.S. Customary	SI/Metric
<p>Example 4. Calculate the deflection (Δ) of a beam with a concentrated force (F) at its midpoint a distance ($L/4$) from the left end of the beam, where</p> <p>$F = 12 \text{ kip} = 12,000 \text{ lb}$ $L = 6 \text{ ft}$ $E = 30 \times 10^6 \text{ lb/in}^2$ (steel) $I = 2.25 \text{ in}^4$</p> <p>solution <i>Step 1.</i> Determine the distance (x).</p> $x = \frac{L}{4} = \frac{6 \text{ ft}}{4} = 1.5 \text{ ft}$ <p><i>Step 2.</i> Calculate the stiffness (EI).</p> $\begin{aligned} EI &= (30 \times 10^6 \text{ lb/in}^2)(2.25 \text{ in}^4) \\ &= 6.75 \times 10^7 \text{ lb} \cdot \text{in}^2 \times 1 \text{ ft}^2/144 \text{ in}^2 \\ &= 4.69 \times 10^5 \text{ lb} \cdot \text{ft}^2 \end{aligned}$ <p><i>Step 3.</i> Determine the deflection (Δ) from Eq. (2.4).</p> $\begin{aligned} \Delta &= \frac{Fx}{48(EI)}(3L^2 - 4x^2) \\ &= \frac{(12,000 \text{ lb})(1.5 \text{ ft})}{48(4.69 \times 10^5 \text{ lb} \cdot \text{ft}^2)} \\ &\quad \times [3(6 \text{ ft})^2 - 4(1.5 \text{ ft})^2] \\ &= \frac{(18,000 \text{ lb} \cdot \text{ft})}{(2.25 \times 10^7 \text{ lb} \cdot \text{ft}^2)} \\ &\quad \times [(108 \text{ ft}^2) - (9 \text{ ft}^2)] \\ &= \left(8.00 \times 10^{-4} \frac{1}{\text{ft}}\right) \times [99 \text{ ft}^2] \\ &= 0.079 \text{ ft} \times \frac{12 \text{ in}}{\text{ft}} = 0.95 \text{ in} \downarrow \end{aligned}$ <p>Example 5. Calculate the maximum deflection (Δ_{max}) and its location for the beam configuration in Example 4, where</p> <p>$F = 12 \text{ kip} = 12,000 \text{ lb}$ $L = 6 \text{ ft}$ $EI = 4.69 \times 10^5 \text{ lb} \cdot \text{ft}^2$</p>	<p>Example 4. Calculate the deflection (Δ) of a beam with a concentrated force (F) at its midpoint a distance ($L/4$) from the left end of the beam, where</p> <p>$F = 55 \text{ kN} = 55,000 \text{ N}$ $L = 2 \text{ m}$ $E = 207 \times 10^9 \text{ N/m}^2$ (steel) $I = 88 \text{ cm}^4$</p> <p>solution <i>Step 1.</i> Determine the distance (x).</p> $x = \frac{L}{4} = \frac{2 \text{ m}}{4} = 0.5 \text{ m}$ <p><i>Step 2.</i> Calculate the stiffness (EI).</p> $\begin{aligned} EI &= (207 \times 10^9 \text{ N/m}^2)(88 \text{ cm}^4) \\ &\quad \times 1 \text{ m}^4/(100 \text{ cm})^4 \\ &= 1.82 \times 10^5 \text{ N} \cdot \text{m}^2 \end{aligned}$ <p><i>Step 3.</i> Determine the deflection (Δ) from Eq. (2.4).</p> $\begin{aligned} \Delta &= \frac{Fx}{48(EI)}(3L^2 - 4x^2) \\ &= \frac{(55,000 \text{ N})(0.5 \text{ m})}{48(1.82 \times 10^5 \text{ N} \cdot \text{m}^2)} \\ &\quad \times [3(2 \text{ m})^2 - 4(0.5 \text{ m})^2] \\ &= \frac{(27,500 \text{ N} \cdot \text{m})}{(8.74 \times 10^6 \text{ N} \cdot \text{m}^2)} \\ &\quad \times [(12 \text{ m}^2) - (1 \text{ m}^2)] \\ &= \left(3.15 \times 10^{-3} \frac{1}{\text{m}}\right) \times [11 \text{ m}^2] \\ &= 0.0346 \text{ m} \times \frac{100 \text{ cm}}{\text{m}} = 3.46 \text{ cm} \downarrow \end{aligned}$ <p>Example 5. Calculate the maximum deflection (Δ_{max}) and its location for the beam configuration in Example 4, where</p> <p>$F = 55 \text{ kN} = 55,000 \text{ N}$ $L = 2 \text{ m}$ $EI = 1.82 \times 10^5 \text{ N} \cdot \text{m}^2$</p>

U.S. Customary	SI/Metric
<p>solution <i>Step 1.</i> Calculate the maximum deflection from Eq. (2.5).</p> $\Delta_{\max} = \frac{FL^3}{48(EI)}$ $= \frac{(12,000 \text{ lb})(6 \text{ ft})^3}{48(4.69 \times 10^5 \text{ lb} \cdot \text{ft}^2)}$ $= \frac{2.59 \times 10^6 \text{ lb} \cdot \text{ft}^3}{2.25 \times 10^7 \text{ lb} \cdot \text{ft}^2}$ $= 0.115 \text{ ft} \times \frac{12 \text{ in}}{\text{ft}} = 1.38 \text{ in} \downarrow$	<p>solution <i>Step 1.</i> Calculate the maximum deflection from Eq. (2.5).</p> $\Delta_{\max} = \frac{FL^3}{48(EI)}$ $= \frac{(55,000 \text{ N})(2 \text{ m})^3}{48(1.82 \times 10^5 \text{ N} \cdot \text{m}^2)}$ $= \frac{4.40 \times 10^5 \text{ N} \cdot \text{m}^3}{8.74 \times 10^6 \text{ N} \cdot \text{m}^2}$ $= 0.0504 \text{ m} \times \frac{100 \text{ cm}}{\text{m}} = 5.04 \text{ cm} \downarrow$

Notice that the maximum deflection (Δ_{\max}) found at the midpoint of the beam ($L/2$) in Example 5 is not twice the deflection (Δ) at a distance one quarter the length of the beam ($L/4$) found in Example 4. This is because the shape of the deflection curve is parabolic, not linear.

2.2.2 Concentrated Force at Intermediate Point

The simply-supported beam in Fig. 2.16 has a concentrated force (F) acting vertically downward at an intermediate point, meaning not at its midpoint. The distance between the supports is labeled (L), so the force (F) is located at a distance (a) from the left end of the beam and a distance (b) from the right end of the beam, where the sum of distances (a) and (b) equal the length of the beam (L).

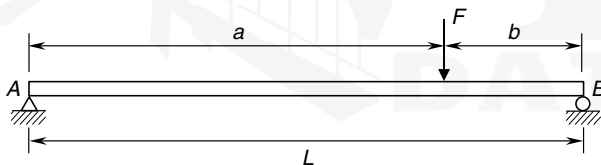

FIGURE 2.16 Concentrated force at intermediate point.

Reactions. The reactions at the end supports are shown in Fig. 2.17, the balanced free-body-diagram. Notice that the force (F) is unevenly divided between the vertical reactions (A_y and B_y), and because the force (F) is acting straight down, the horizontal reaction

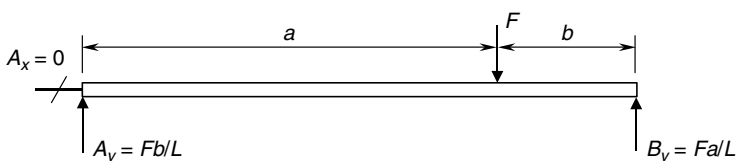

FIGURE 2.17 Free-body-diagram.

(A_x) is zero. If the force (F) had a horizontal component, then the horizontal reaction (A_x) would be equal, but opposite in direction, to this horizontal component.

U.S. Customary	SI/Metric
<p>Example 1. Determine the reactions at the ends of a simply-supported beam of length (L) with a concentrated force (F) acting at an intermediate point, where</p> <p>$F = 10 \text{ kip} = 10,000 \text{ lb}$ $L = 8 \text{ ft}, a = 6 \text{ ft}, b = 2 \text{ ft}$</p> <p>solution</p> <p><i>Step 1.</i> From Fig. 2.17, calculate the pin reactions (A_x and A_y) at the left end of the beam. As the force (F) is vertical,</p> $A_x = 0$ <p>and the vertical reaction (A_y) is</p> $A_y = \frac{Fb}{L} = \frac{(10,000 \text{ lb})(2 \text{ ft})}{8 \text{ ft}} = \frac{20,000 \text{ ft} \cdot \text{lb}}{8 \text{ ft}} = 2,500 \text{ lb}$ <p><i>Step 2.</i> From Fig. 2.17 calculate the roller reaction (B_y) at the right end of the beam.</p> $B_y = \frac{Fa}{L} = \frac{(10,000 \text{ lb})(6 \text{ ft})}{8 \text{ ft}} = \frac{60,000 \text{ ft} \cdot \text{lb}}{8 \text{ ft}} = 7,500 \text{ lb}$	<p>Example 1. Determine the reactions at the ends of a simply-supported beam of length (L) with a concentrated force (F) acting at an intermediate point, where</p> <p>$F = 45 \text{ kN} = 45,000 \text{ N}$ $L = 3 \text{ m}, a = 2 \text{ m}, b = 1 \text{ m}$</p> <p>solution</p> <p><i>Step 1.</i> From Fig. 2.17, calculate the pin reactions (A_x and A_y) at the left end of the beam. As the force (F) is vertical,</p> $A_x = 0$ <p>and the vertical reaction (A_y) is</p> $A_y = \frac{Fb}{L} = \frac{(45,000 \text{ N})(1 \text{ m})}{3 \text{ m}} = \frac{45,000 \text{ N} \cdot \text{m}}{3 \text{ m}} = 15,000 \text{ N}$ <p><i>Step 2.</i> From Fig. 2.17 calculate the roller reaction (B_y) at the right end of the beam.</p> $B_y = \frac{Fa}{L} = \frac{(45,000 \text{ N})(2 \text{ m})}{3 \text{ m}} = \frac{90,000 \text{ N} \cdot \text{m}}{3 \text{ m}} = 30,000 \text{ N}$

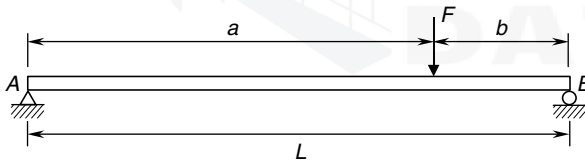

FIGURE 2.18 Concentrated force at intermediate point.

Shear Force and Bending Moment Distributions. For the simply-supported beam with a concentrated force (F) at an intermediate point, shown in Fig. 2.18, that has the balanced free-body-diagram shown in Fig. 2.19, the shear force (V) distribution is shown in Fig. 2.20.

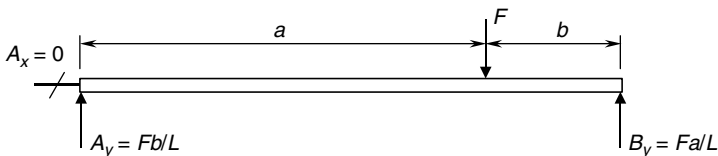

FIGURE 2.19 Free-body-diagram.

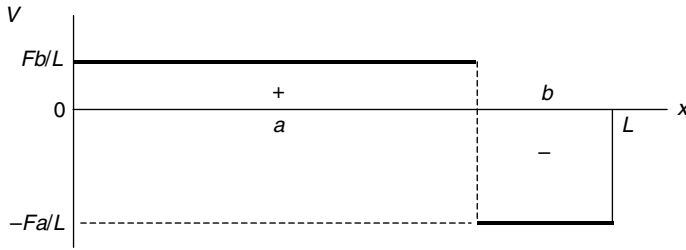

FIGURE 2.20 Shear force diagram.

Note that the shear force (V) is a positive (Fb/L) from the left end of the beam to where the force acts, and a negative (Fa/L) from where the force acts to the right end of the beam. So there is a discontinuity in the shear force where the force acts, of magnitude (F). If the distance (a) is greater than the distance (b), then the maximum shear force (V_{\max}) is

$$V_{\max} = \frac{Fa}{L} \quad a > b \quad (2.6)$$

The bending moment distribution is given by Eq. (2.7a) for values of the distance (x) from the left end of the beam to where the force acts, and Eq. (2.7b) from where the force acts to the right end of the beam. (Always measure the distance (x) from the left end of any beam.)

$$M = \frac{Fb}{L}x \quad 0 \leq x \leq a \quad (2.7a)$$

$$M = \frac{Fa}{L}(L - x) \quad a \leq x \leq L \quad (2.7b)$$

The bending moment (M) distribution is shown in Fig. 2.21.

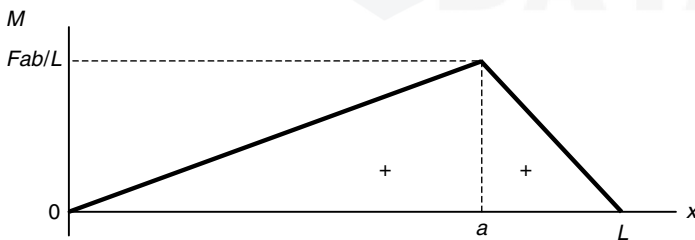

FIGURE 2.21 Bending moment diagram.

Note that the bending moment (M) is zero at both ends, and increases linearly to a maximum where the force acts. From where the force acts, the bending moment decreases linearly back to zero. The maximum bending moment (M_{\max}) is given by Eq. (2.8)

$$M_{\max} = \frac{Fab}{L} \quad (2.8)$$

U.S. Customary	SI/Metric
<p>Example 2. Calculate the shear force (V) and bending moment (M) for a simply-supported beam with a concentrated force (F) at an intermediate point a distance ($L/2$), where</p> $F = 10 \text{ kip} = 10,000 \text{ lb}$ $L = 8 \text{ ft}, a = 6 \text{ ft}, b = 2 \text{ ft}$	<p>Example 2. Calculate the shear force (V) and bending moment (M) for a simply-supported beam with a concentrated force (F) at an intermediate point a distance ($L/2$), where</p> $F = 45 \text{ kN} = 45,000 \text{ N}$ $L = 3 \text{ m}, a = 2 \text{ m}, b = 1 \text{ m}$
<p>solution</p> <p><i>Step 1.</i> Establish the distance (x) from the left end of the beam, where</p>	<p>solution</p> <p><i>Step 1.</i> Establish the distance (x) from the left end of the beam, where</p>
$x = \frac{L}{2} = \frac{8 \text{ ft}}{2} = 4 \text{ ft}$	$x = \frac{L}{2} = \frac{3 \text{ m}}{2} = 1.5 \text{ m}$
<p><i>Step 2.</i> Determine the shear force (V) from Fig. 2.20 as</p>	<p><i>Step 2.</i> Determine the shear force (V) from Fig. 2.20 as</p>
$V = \frac{Fb}{L} = \frac{(10,000 \text{ lb})(2 \text{ ft})}{8 \text{ ft}}$ $= \frac{20,000 \text{ ft} \cdot \text{lb}}{8 \text{ ft}} = 2,500 \text{ lb}$	$V = \frac{Fb}{L} = \frac{(45,000 \text{ N})(1 \text{ m})}{3 \text{ m}}$ $= \frac{45,000 \text{ N} \cdot \text{m}}{3 \text{ m}} = 15,000 \text{ N}$
<p><i>Step 3.</i> Determine the bending moment (M) from Eq. (2.7a).</p>	<p><i>Step 3.</i> Determine the bending moment (M) from Eq. (2.7a).</p>
$M = \frac{Fb}{L} x = \frac{(10,000 \text{ lb})(2 \text{ ft})}{8 \text{ ft}}(4 \text{ ft})$ $= \frac{20,000 \text{ ft} \cdot \text{lb}}{8 \text{ ft}}(4 \text{ ft})$ $= (2,500 \text{ lb})(4 \text{ ft}) = 10,000 \text{ ft} \cdot \text{lb}$	$M = \frac{Fb}{L} x = \frac{(45,000 \text{ N})(1 \text{ m})}{3 \text{ m}}(1.5 \text{ m})$ $= \frac{45,000 \text{ N} \cdot \text{m}}{3 \text{ m}}(1.5 \text{ m})$ $= (15,000 \text{ N})(1.5 \text{ m}) = 22,500 \text{ N} \cdot \text{m}$
<p>Example 3. Calculate and locate the maximum shear force (V_{\max}) and the maximum bending moment (M_{\max}) for the beam of Examples 1 and 2, where</p>	<p>Example 3. Calculate and locate the maximum shear force (V_{\max}) and the maximum bending moment (M_{\max}) for the beam of Examples 1 and 2, where</p>
$F = 10 \text{ kip} = 10,000 \text{ lb}$ $L = 8 \text{ ft}, a = 6 \text{ ft}, b = 2 \text{ ft}$	$F = 45 \text{ kN} = 45,000 \text{ N}$ $L = 3 \text{ m}, a = 2 \text{ m}, b = 1 \text{ m}$
<p>solution</p> <p><i>Step 1.</i> Calculate the maximum shear force (V_{\max}) from Eq. (2.6) as</p>	<p>solution</p> <p><i>Step 1.</i> Calculate the maximum shear force (V_{\max}) from Eq. (2.6) as</p>
$V_{\max} = \frac{Fa}{L} = \frac{(10,000 \text{ lb})(6 \text{ ft})}{8 \text{ ft}}$ $= \frac{60,000 \text{ ft} \cdot \text{lb}}{8 \text{ ft}} = 7,500 \text{ lb}$	$V_{\max} = \frac{Fa}{L} = \frac{(45,000 \text{ N})(2 \text{ m})}{3 \text{ m}}$ $= \frac{90,000 \text{ N} \cdot \text{m}}{3 \text{ m}} = 30,000 \text{ N}$
<p><i>Step 2.</i> As shown in Fig. 2.20 this maximum shear force (V_{\max}) of 7,500 lb occurs in the region between where the force (F) acts and the right end of the beam.</p>	<p><i>Step 2.</i> As shown in Fig. 2.20, this maximum shear force (V_{\max}) of 30,000 N occurs in the region between where the force (F) acts and the right end of the beam.</p>

U.S. Customary	SI/Metric
<p><i>Step 3.</i> Calculate the maximum bending moment (M_{\max}) from Eq. (2.8) as</p> $M_{\max} = \frac{Fab}{L} = \frac{(10,000 \text{ lb})(6 \text{ ft})(2 \text{ ft})}{8 \text{ ft}}$ $= \frac{120,000 \text{ ft}^2 \cdot \text{lb}}{8 \text{ ft}} = 15,000 \text{ ft} \cdot \text{lb}$ <p><i>Step 4.</i> Figure 2.21, this maximum bending moment (M_{\max}) of 15,000 ft · lb occurs where the force (F) acts.</p>	<p><i>Step 3.</i> Calculate the maximum bending moment (M_{\max}) from Eq. (2.8) as</p> $M_{\max} = \frac{Fab}{L} = \frac{(45,000 \text{ N})(2 \text{ m})(1 \text{ m})}{3 \text{ m}}$ $= \frac{90,000 \text{ N} \cdot \text{m}^2}{3 \text{ m}} = 30,000 \text{ N} \cdot \text{m}$ <p><i>Step 4.</i> Figure 2.21, this maximum bending moment (M_{\max}) of 30,000 N · m occurs where the force (F) acts.</p>

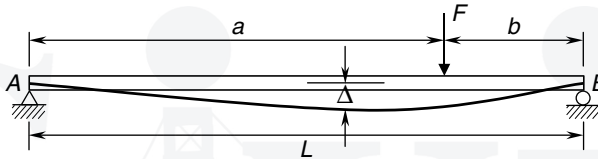

FIGURE 2.22 Beam deflection diagram.

Deflection. For this loading configuration, the deflection (Δ) along the beam is shown in Fig. 2.22, and given by Eq. (2.9a) for values of the distance (x) from the left end of the beam to where the force (F) acts, and given by Eq. (2.9b) for values of the distance (x) from where the force (F) acts to the right end of the beam.

$$\Delta = \frac{Fbx}{6EI} (L^2 - b^2 - x^2) \quad 0 \leq x \leq a \quad (2.9a)$$

$$\Delta = \frac{Fa(L-x)}{6EI} (2Lx - a^2 - x^2) \quad a \leq x \leq L \quad (2.9b)$$

where Δ = deflection of beam

F = applied force at an intermediate point

x = distance from left end of beam

L = length of beam

a = location of force (F) from left end of beam

b = location of force (F) from right end of beam

E = modulus of elasticity of beam material

I = area moment of inertia of the cross-sectional area about axis through centroid

Note that the deflection (Δ) is downward for all values of the distance (x), and that the distance (x) in Eq. (2.9a) must be between 0 and the distance (a), and the distance (x) in Eq. (2.9b) must be between the distance (a) and the length of the beam (L). The deflection will not be symmetrical about the location of the force (F), and as will be seen shortly, the maximum deflection does not occur where the force acts.

If the distance (a) is greater than the distance (b), then the maximum deflection (Δ_{\max}) caused by this loading configuration is given by Eq. (2.10),

$$\Delta_{\max} = \frac{Fb}{3EI} \left(\frac{a(L+b)}{3} \right)^{3/2} \quad \text{at } x = \sqrt{\frac{a(L+b)}{3}} \quad (2.10)$$

located at a point to the left of where the force (F) acts. It is clear that the distance (x) for the maximum deflection is not the place where the force (F) acts.

If the distance (a) is less than the distance (b), then consider a mirror image of the beam where the distances (a) and (b) swap values.

The deflection (Δ_a) at the point where the force (F) acts, the distance (a), is given by Eq. (2.11),

$$\Delta_a = \frac{Fa^2b^2}{3EI} \quad \text{at } x = a \quad (2.11)$$

where it is not entirely obvious that the deflection (Δ_a) is less than the maximum deflection (Δ_{\max}).

U.S. Customary	SI/Metric
<p>Example 4. Calculate the deflection (Δ) of a simply-supported beam with a concentrated force (F) at an intermediate point a distance (x) of ($3L/8$), where</p> <p>$F = 10 \text{ kip} = 10,000 \text{ lb}$ $L = 8 \text{ ft}, a = 6 \text{ ft}, b = 2 \text{ ft}$ $E = 30 \times 10^6 \text{ lb/in.}^2 \text{ (steel)}$ $I = 4 \text{ in}^4$</p> <p>solution</p> <p><i>Step 1.</i> Determine the distance (x).</p> $x = \frac{3L}{8} = \frac{3(8 \text{ ft})}{8} = 3 \text{ ft}$ <p><i>Step 2.</i> Calculate the stiffness (EI).</p> $\begin{aligned} EI &= (30 \times 10^6 \text{ lb/in}^2)(4 \text{ in}^4) \\ &= \frac{1.2 \times 10^8 \text{ lb} \cdot \text{in}^2 \times 1 \text{ ft}^2}{144 \text{ in}^2} \\ &= 8.33 \times 10^5 \text{ lb} \cdot \text{ft}^2 \end{aligned}$ <p><i>Step 3.</i> Determine the deflection (Δ) from Eq. (2.9a).</p> $\begin{aligned} \Delta &= \frac{Fbx}{6(EI)L} (L^2 - b^2 - x^2) \\ &= \frac{(10,000 \text{ lb})(2 \text{ ft})(3 \text{ ft})}{6(8.33 \times 10^5 \text{ lb} \cdot \text{ft}^2)(8 \text{ ft})} \\ &\quad \times [(8 \text{ ft})^2 - (2 \text{ ft})^2 - (3 \text{ ft})^2] \end{aligned}$	<p>Example 4. Calculate the deflection (Δ) of a simply-supported beam with a concentrated force (F) at an intermediate point a distance (x) of ($3L/8$), where</p> <p>$F = 45 \text{ kN} = 45,000 \text{ N}$ $L = 3 \text{ m}, a = 2 \text{ m}, b = 1 \text{ m}$ $E = 207 \times 10^9 \text{ N/m}^2 \text{ (steel)}$ $I = 201 \text{ cm}^4$</p> <p>solution</p> <p><i>Step 1.</i> Determine the distance (x).</p> $x = \frac{3L}{8} = \frac{3(3 \text{ m})}{8} = 1.125 \text{ m}$ <p><i>Step 2.</i> Calculate the stiffness (EI).</p> $\begin{aligned} EI &= (207 \times 10^9 \text{ N/m}^2)(201 \text{ cm}^4) \\ &\quad \times \frac{1 \text{ m}^4}{(100 \text{ cm})^4} \\ &= 4.16 \times 10^5 \text{ N} \cdot \text{m}^2 \end{aligned}$ <p><i>Step 3.</i> Determine the deflection (Δ) from Eq. (2.9a).</p> $\begin{aligned} \Delta &= \frac{Fbx}{6(EI)L} (L^2 - b^2 - x^2) \\ &= \frac{(45,000 \text{ N})(1 \text{ m})(1.125 \text{ m})}{6(4.16 \times 10^5 \text{ N} \cdot \text{m}^2)(3 \text{ m})} \\ &\quad \times [(3 \text{ m})^2 - (1 \text{ m})^2 - (1.125 \text{ m})^2] \end{aligned}$

U.S. Customary	SI/Metric
$\Delta = \frac{(60,000 \text{ lb} \cdot \text{ft}^2)}{(4.00 \times 10^7 \text{ lb} \cdot \text{ft}^3)} \times [(64 \text{ ft}^2) - (4 \text{ ft}^2) - (9 \text{ ft}^2)]$ $= \left(1.5 \times 10^{-3} \frac{1}{\text{ft}}\right) \times [51 \text{ ft}^2]$ $= 0.0765 \text{ ft} \times \frac{12 \text{ in}}{\text{ft}} = 0.92 \text{ in} \downarrow$	$\Delta = \frac{(50,625 \text{ N} \cdot \text{m}^2)}{(7.49 \times 10^6 \text{ N} \cdot \text{m}^3)} \times [(9 \text{ m}^2) - (1 \text{ m}^2) - (1.27 \text{ m}^2)]$ $= \left(6.76 \times 10^{-3} \frac{1}{\text{m}}\right) \times [6.73 \text{ m}^2]$ $= 0.0455 \text{ m} \times \frac{100 \text{ cm}}{\text{m}} = 4.55 \text{ cm} \downarrow$
<p>Example 5. Calculate the maximum deflection (Δ_{\max}) and its location for the beam configuration in Example 4, where</p> <p>$F = 10 \text{ kip} = 10,000 \text{ lb}$ $L = 8 \text{ ft}, a = 6 \text{ ft}, b = 2 \text{ ft}$ $EI = 8.33 \times 10^5 \text{ lb} \cdot \text{ft}^2$</p>	<p>Example 5. Calculate the maximum deflection (Δ_{\max}) and its location for the beam configuration in Example 4, where</p> <p>$F = 45 \text{ kN} = 45,000 \text{ N}$ $L = 3 \text{ m}, a = 2 \text{ m}, b = 1 \text{ m}$ $EI = 4.16 \times 10^5 \text{ N} \cdot \text{m}^2$</p>
<p>solution</p> <p><i>Step 1.</i> Calculate the maximum deflection from Eq. (2.10).</p>	<p>solution</p> <p><i>Step 1.</i> Calculate the maximum deflection from Eq. (2.10).</p>
$\Delta_{\max} = \frac{Fb}{3(EI)L} \left(\frac{a(L+b)}{3}\right)^{3/2}$ $= \frac{(10,000 \text{ lb})(2 \text{ ft})}{3(8.33 \times 10^5 \text{ lb} \cdot \text{ft}^2)(8 \text{ ft})} \times \left(\frac{(6 \text{ ft})[(8 \text{ ft}) + (2 \text{ ft})]}{3}\right)^{3/2}$ $\Delta_{\max} = \frac{20,000 \text{ lb} \cdot \text{ft}}{2.00 \times 10^7 \text{ lb} \cdot \text{ft}^3} \times \left(\frac{(60 \text{ ft}^2)}{3}\right)^{3/2}$ $= \left(1.00 \times 10^{-3} \frac{1}{\text{ft}^2}\right) (89.4 \text{ ft}^3)$ $= 0.089 \text{ ft} \times \frac{12 \text{ in}}{\text{ft}} = 1.07 \text{ in} \downarrow$	$\Delta_{\max} = \frac{Fb}{3EIL} \left(\frac{a(L+b)}{3}\right)^{3/2}$ $= \frac{(45,000 \text{ N})(1 \text{ m})}{3(4.16 \times 10^5 \text{ N} \cdot \text{m}^2)(3 \text{ m})} \times \left(\frac{(2 \text{ m})[(3 \text{ m}) + (1 \text{ m})]}{3}\right)^{3/2}$ $\Delta_{\max} = \frac{45,000 \text{ N} \cdot \text{m}}{3.74 \times 10^6 \text{ N} \cdot \text{m}^3} \times \left(\frac{(8 \text{ m}^2)}{3}\right)^{3/2}$ $= \left(1.20 \times 10^{-2} \frac{1}{\text{m}^2}\right) (4.35 \text{ m}^3)$ $= 0.0523 \text{ m} \times \frac{100 \text{ cm}}{\text{m}} = 5.23 \text{ cm} \downarrow$
<p><i>Step 2.</i> Calculate the location of the maximum deflection from Eq. (2.10).</p>	<p><i>Step 2.</i> Calculate the location of the maximum deflection from Eq. (2.10).</p>
$x_{\Delta_{\max}} = \sqrt{\frac{a(L+b)}{3}}$ $= \sqrt{\frac{(6 \text{ ft})[(8 \text{ ft}) + (2 \text{ ft})]}{3}}$ $= \sqrt{\frac{(6 \text{ ft})(10 \text{ ft})}{3}}$ $= \sqrt{\frac{(60 \text{ ft}^2)}{3}} = 4.47 \text{ ft}$	$x_{\Delta_{\max}} = \sqrt{\frac{a(L+b)}{3}}$ $= \sqrt{\frac{(2 \text{ m})[(3 \text{ m}) + (1 \text{ m})]}{3}}$ $= \sqrt{\frac{(2 \text{ m})(4 \text{ m})}{3}}$ $= \sqrt{\frac{(8 \text{ m}^2)}{3}} = 1.63 \text{ m}$

U.S. Customary	SI/Metric
<p>Example 6. Calculate the deflection (Δ_a) at the location (a) where the force (F) acts, where</p> $F = 10 \text{ kip} = 10,000 \text{ lb}$ $L = 8 \text{ ft}, a = 6 \text{ ft}, b = 2 \text{ ft}$ $EI = 8.33 \times 10^5 \text{ lb} \cdot \text{ft}^2$ <p>solution Calculate the deflection (Δ_a) where the force (F) acts from Eq. (2.11).</p> $\Delta_a = \frac{Fa^2b^2}{3(EI)L}$ $= \frac{(10,000 \text{ lb})(6 \text{ ft})^2(2 \text{ ft})^2}{3(8.33 \times 10^5 \text{ lb} \cdot \text{ft}^2)(8 \text{ ft})}$ $= \frac{1.44 \times 10^6 \text{ lb} \cdot \text{ft}^4}{2.00 \times 10^7 \text{ lb} \cdot \text{ft}^3}$ $= 0.072 \text{ ft} \times \frac{12 \text{ in}}{\text{ft}} = 0.86 \text{ in} \downarrow$	<p>Example 6. Calculate the deflection (Δ_a) at the location (a) where the force (F) acts, where</p> $F = 45 \text{ kN} = 45,000 \text{ N}$ $L = 3 \text{ m}, a = 2 \text{ m}, b = 1 \text{ m}$ $EI = 4.16 \times 10^5 \text{ N} \cdot \text{m}^2$ <p>solution Calculate the deflection (Δ_a) where the force (F) acts from Eq. (2.11).</p> $\Delta_a = \frac{Fa^2b^2}{3(EI)L}$ $= \frac{(45,000 \text{ N})(2 \text{ m})^2(1 \text{ m})^2}{3(4.16 \times 10^5 \text{ N} \cdot \text{m}^2)(3 \text{ m})}$ $= \frac{180,000 \text{ N} \cdot \text{m}^4}{3.74 \times 10^6 \text{ N} \cdot \text{m}^3}$ $= 0.0481 \text{ m} \times \frac{100 \text{ cm}}{\text{m}} = 4.81 \text{ cm} \downarrow$

Notice that the maximum deflection (Δ_{\max}) found in Example 5 is greater than the deflection (Δ_a) found in Example 6, which shows conclusively that the maximum deflection does not occur where the force (F) acts.

2.2.3 Concentrated Couple

The simply-supported beam in Fig. 2.23 has a concentrated couple (C) acting counterclockwise at an intermediate point, not at its midpoint. The distance between the supports is labeled (L), so the couple (C) is located at a distance (a) from the left end of the beam and a distance (b) from the right end of the beam, where the sum of distances (a) and (b) is equal to the length of the beam (L).

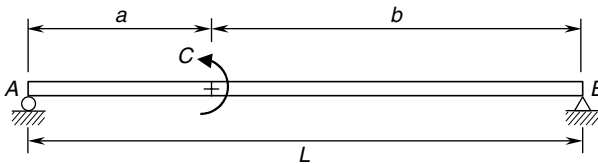

FIGURE 2.23 Concentrated couple at intermediate point.

Reactions. The reactions at the end supports are shown in Fig. 2.24—the balanced free-body-diagram. Notice that as the couple (C) is counterclockwise, the pin support must be located at the right end of the beam, with the roller support at the left. Notice that the vertical reactions (A_y and B_y) are equal in magnitude but opposite in direction, and as there is no force acting on the beam, the horizontal reaction (B_x) is zero.

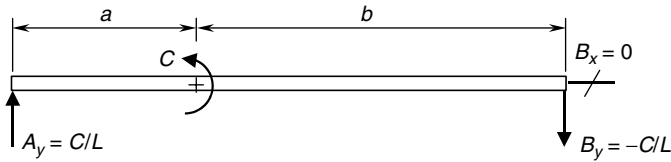

FIGURE 2.24 Free-body diagram.

U.S. Customary	SI/Metric
<p>Example 1. Determine the reactions at the ends of a simply-supported beam of length (L) with a concentrated couple (C) acting at an intermediate point, where</p> $C = 15 \text{ ft} \cdot \text{kip} = 15,000 \text{ ft} \cdot \text{lb}$ $L = 12 \text{ ft}, a = 4 \text{ ft}, b = 8 \text{ ft}$ <p>solution</p> <p><i>Step 1.</i> From Fig. 2.24 calculate the pin reactions (B_x and B_y) at the right end of the beam. As there are no forces acting on the beam,</p> $B_x = 0$ <p>and the vertical reaction (B_y) is</p> $B_y = -\frac{C}{L} = \frac{-15,000 \text{ ft} \cdot \text{lb}}{12 \text{ ft}}$ $= -1,250 \text{ lb}$ <p><i>Step 2.</i> From Fig. 2.24 calculate the roller reaction (A_y) at the left end of the beam.</p> $A_y = \frac{C}{L} = \frac{15,000 \text{ ft} \cdot \text{lb}}{12 \text{ ft}}$ $= 1,250 \text{ lb}$	<p>Example 1. Determine the reactions at the ends of a simply-supported beam of length (L) with a concentrated couple (C) acting at an intermediate point, where</p> $C = 20 \text{ kN} \cdot \text{m} = 20,000 \text{ N} \cdot \text{m}$ $L = 4 \text{ m}, a = 1\frac{1}{2} \text{ m}, b = 2\frac{1}{2} \text{ m}$ <p>solution</p> <p><i>Step 1.</i> From Fig. 2.24 calculate the pin reactions (B_x and B_y) at the right end of the beam. As there are no forces acting on the beam,</p> $B_x = 0$ <p>and the vertical reaction (B_y) is</p> $B_y = -\frac{C}{L} = \frac{-20,000 \text{ N} \cdot \text{m}}{4 \text{ m}}$ $= -5,000 \text{ N}$ <p><i>Step 2.</i> From Fig. 2.24 calculate the roller reaction (A_y) at the left end of the beam.</p> $A_y = \frac{C}{L} = \frac{20,000 \text{ N} \cdot \text{m}}{4 \text{ m}}$ $= 5,000 \text{ N}$

Shear Force and Bending Moment Distributions. For the simply-supported beam with a concentrated couple (C) at an intermediate point, shown in Fig. 2.25, which has the balanced free-body diagram shown in Fig. 2.26, the shear force (V) distribution is shown in Fig. 2.27.

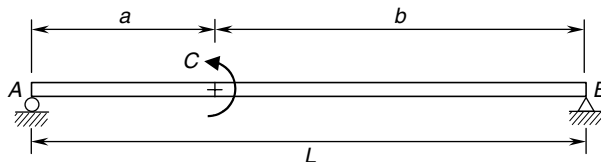

FIGURE 2.25 Concentrated couple at intermediate point.

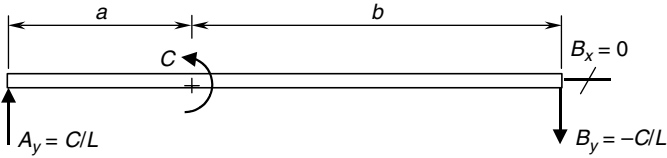

FIGURE 2.26 Free-body-diagram.

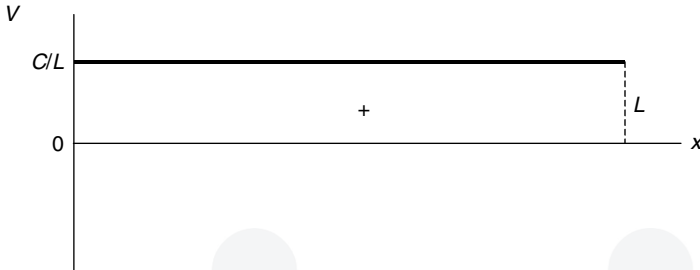

FIGURE 2.27 Shear force diagram.

Note that the shear force (V) is a constant (C/L) from the left end of the beam to the right end of the beam. As the couple is not a force, its location does not affect the shear force distribution, unlike a concentrated force that causes a discontinuity in the shear force distribution where the force acts. Therefore, the maximum shear force (V_{\max}) is given by Eq. (2.12).

$$V_{\max} = \frac{C}{L} \quad (2.12)$$

The bending moment (M) distribution is given by Eq. (2.13a) for the values of the distance (x) from the left end of the beam to where the couple acts and Eq. (2.13b) from where the couple acts to the right end of the beam. (Always measure the distance (x) from the left end of any beam.)

$$M = \frac{C}{L} x \quad 0 \leq x \leq a \quad (2.13a)$$

$$M = -\frac{C}{L}(L - x) \quad a \leq x \leq L \quad (2.13b)$$

The bending moment (M) distribution is shown in Fig. 2.28.

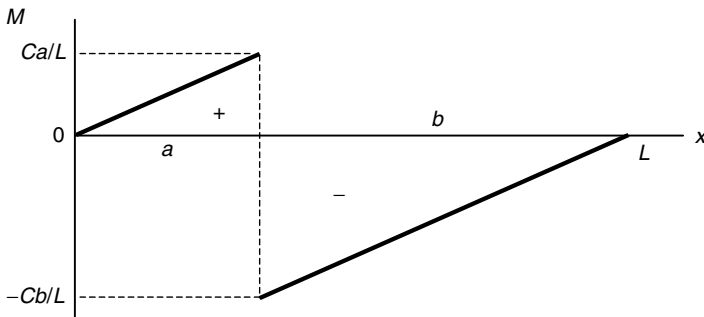

FIGURE 2.28 Bending moment diagram.

Note that the bending moment (M) is zero at both ends, and increases linearly to a maximum positive value (Ca/L) where the couple acts. At the point where the couple acts, that is at a distance (a), there is a discontinuity in the bending moment of magnitude (C) downward. So from where the couple acts, the bending moment starts at a maximum negative value ($-Cb/L$) and increases linearly back to zero. Note that the slopes of these two increasing values of bending moment are equal, and therefore the lines are parallel.

If the distance (a) is less than the distance (b), then the maximum bending moment (M_{\max}) is given by Eq. (2.14a). If the distance (a) is greater than the distance (b), then the maximum bending moment (M_{\max}) is given by Eq. (2.14b).

$$M_{\max} = \frac{Cb}{L} \quad a < b \quad (2.14a)$$

$$M_{\max} = \frac{Ca}{L} \quad a > b \quad (2.14b)$$

If the distance (a) is equal to the distance (b), which means the couple (C) acts at the midpoint of the beam, then (a) and (b) each is equal to half the length of the beam (L). Therefore, the bending moment distribution will be symmetrical about the midpoint of the beam, and the maximum bending moment (M_{\max}) is given by Eq. (2.15)

$$M_{\max} = \frac{C}{2} \quad a = b = \frac{L}{2} \quad (2.15)$$

U.S. Customary	SI/Metric
<p>Example 2. Calculate the shear force (V) and bending moment (M) for a simply-supported beam with a concentrated couple (C) at a distance ($L/6$) from the left end of the beam, where</p> <p>$C = 15 \text{ ft} \cdot \text{kip} = 15,000 \text{ ft} \cdot \text{lb}$ $L = 12 \text{ ft}, a = 4 \text{ ft}, b = 8 \text{ ft}$</p> <p>solution</p> <p><i>Step 1.</i> Establish the distance (x) from the left end of the beam, where</p> $x = \frac{L}{6} = \frac{12 \text{ ft}}{6} = 2 \text{ ft}$ <p><i>Step 2.</i> Determine the shear force (V) from Fig. 2.27 as</p> $V = \frac{C}{L} = \frac{15,000 \text{ ft} \cdot \text{lb}}{12 \text{ ft}} = 1,250 \text{ lb}$ <p><i>Step 3.</i> Determine the bending moment (M) from Eq. (2.13a).</p> $M = \frac{C}{L} x = \frac{15,000 \text{ ft} \cdot \text{lb}}{12 \text{ ft}} (2 \text{ ft}) = (1,250 \text{ lb}) (2 \text{ ft}) = 2,500 \text{ ft} \cdot \text{lb}$	<p>Example 2. Calculate the shear force (V) and bending moment (M) for a simply-supported beam with a concentrated couple (C) at a distance ($L/4$) from the left end of the beam, where</p> <p>$F = 20 \text{ kN} \cdot \text{m} = 20,000 \text{ N} \cdot \text{m}$ $L = 4 \text{ m}, a = 1\frac{1}{2} \text{ m}, b = 2\frac{1}{2} \text{ m}$</p> <p>solution</p> <p><i>Step 1.</i> Establish the distance (x) from the left end of the beam, where</p> $x = \frac{L}{4} = \frac{4 \text{ m}}{4} = 1 \text{ m}$ <p><i>Step 2.</i> Determine the shear force (V) from Fig. 2.27 as</p> $V = \frac{C}{L} = \frac{20,000 \text{ N} \cdot \text{m}}{4 \text{ m}} = 5,000 \text{ N}$ <p><i>Step 3.</i> Determine the bending moment (M) from Eq. (2.13a).</p> $M = \frac{C}{L} x = \frac{20,000 \text{ N} \cdot \text{m}}{4 \text{ m}} (1 \text{ m}) = (5,000 \text{ N}) (1 \text{ m}) = 5,000 \text{ N} \cdot \text{m}$

U.S. Customary	SI/Metric
<p>Example 3. Calculate and locate the maximum shear force (V_{\max}) and the maximum bending moment (M_{\max}) for the beam of Examples 1 and 2, where</p> <p style="text-align: center;">$C = 15 \text{ ft} \cdot \text{kip} = 15,000 \text{ ft} \cdot \text{lb}$ $L = 12 \text{ ft}, a = 4 \text{ ft}, b = 8 \text{ ft}$</p> <p>solution</p> <p><i>Step 1.</i> Calculate the maximum shear force (V_{\max}) from Eq. (2.12) as</p> $V_{\max} = \frac{C}{L} = \frac{15,000 \text{ ft} \cdot \text{lb}}{12 \text{ ft}}$ <p style="text-align: center;">$= 1,250 \text{ lb}$</p> <p><i>Step 2.</i> As shown in Fig. 2.27 the maximum shear force (V_{\max}) of 1,250 lb does not have a specific location.</p> <p><i>Step 3.</i> Calculate the maximum bending moment (M_{\max}) from Eq. (2.14a), as the distance (a), the location of the couple (C), is less than the distance (b).</p> $M_{\max} = \frac{Cb}{L} = \frac{(15,000 \text{ ft} \cdot \text{lb})(8 \text{ ft})}{12 \text{ ft}}$ $= \frac{120,000 \text{ ft}^2 \cdot \text{lb}}{12 \text{ ft}} = 10,000 \text{ ft} \cdot \text{lb}$ <p><i>Step 4.</i> Figure 2.28 shows that the maximum bending moment (M_{\max}) of 10,000 ft · lb occurs where the couple (C) acts.</p>	<p>Example 3. Calculate and locate the maximum shear force (V_{\max}) and the maximum bending moment (M_{\max}) for the beam of Examples 1 and 2, where</p> <p style="text-align: center;">$C = 20 \text{ kN} \cdot \text{m} = 20,000 \text{ N} \cdot \text{m}$ $L = 4 \text{ m}, a = 1\frac{1}{2} \text{ m}, b = 2\frac{1}{2} \text{ m}$</p> <p>solution</p> <p><i>Step 1.</i> Calculate the maximum shear force (V_{\max}) from Eq. (2.12) as</p> $V_{\max} = \frac{C}{L} = \frac{20,000 \text{ N} \cdot \text{m}}{4 \text{ m}}$ <p style="text-align: center;">$= 5,000 \text{ N}$</p> <p><i>Step 2.</i> As shown in Fig. 2.27 the maximum shear force (V_{\max}) of 5,000 N · lb does not have a specific location.</p> <p><i>Step 3.</i> Calculate the maximum bending moment (M_{\max}) from Eq. (2.14a), as the distance (a), the location of the couple (C), is less than the distance (b)</p> $M_{\max} = \frac{Cb}{L} = \frac{(20,000 \text{ N} \cdot \text{m})(2.5 \text{ m})}{4 \text{ m}}$ $= \frac{50,000 \text{ N} \cdot \text{m}^2}{4 \text{ m}} = 12,500 \text{ N} \cdot \text{m}$ <p><i>Step 4.</i> Figure 2.28 shows that the maximum bending moment (M_{\max}) of 12,500 N · m occurs where the couple (C) acts.</p>

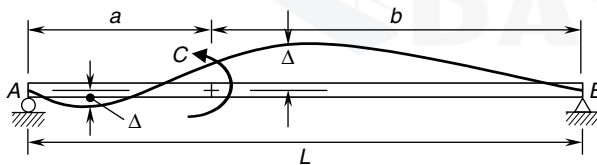

FIGURE 2.29 Beam deflection diagram.

Deflection. For this loading configuration, the deflection (Δ) along the beam is shown in Fig. 2.29, and given by Eq. (2.16a) for the values of the distance (x) from the left end of the beam to where the couple (C) acts, and given by Eq. (2.16b) for the values of the distance (x) from where the couple (C) acts to the right end of the beam.

$$\Delta = \frac{Cx}{6EIL} [6aL - x^2 - 3a^2 - 2L^2] \quad 0 \leq x \leq a \quad (2.16a)$$

$$\Delta = \frac{C}{6EIL} [3a^2L + 3Lx^2 - x(2L^2 + 3a^2) - x^3] \quad a \leq x \leq L \quad (2.16b)$$

where Δ = deflection of beam (positive downward)

C = applied couple at an intermediate point

x = distance from left end of beam

L = length of beam

a = location of couple (C) from left end of beam

b = location of couple (C) from right end of beam

E = modulus of elasticity of beam material

I = area moment of inertia of cross-sectional area about axis through centroid

Note that the deflection (Δ) is downward for some values of the distance (x) and upward for other values. Also, the distance (x) in Eq. (2.16a) must be between 0 and (a), and the distance (x) in Eq. (2.16b) must be between (a) and the length of the beam (L).

The deflection (Δ_a) at the point where the couple (C) acts, which is the distance (a), as given by Eq. (2.17),

$$\Delta_a = \frac{Cab}{3EI} (2a - L) \quad \text{at } x = a \quad (2.17)$$

If the distance (a) is less than half the length of the beam (L), then the deflection (Δ_a) will be above the axis of the beam. If the distance (a) is greater than half the length of the beam, then the deflection (Δ_a) will be below the axis of the beam. If the distance (a) is equal to half the length of the beam, then the deflection (Δ_a) will be zero.

U.S. Customary	SI/Metric
<p>Example 4. Calculate the deflection (Δ) of a simply-supported beam with a concentrated couple (C) a distance (x) of ($L/6$), where</p> <p>$C = 15 \text{ ft} \cdot \text{kip} = 15,000 \text{ ft} \cdot \text{lb}$ $L = 12 \text{ ft}, a = 4 \text{ ft}, b = 8 \text{ ft}$ $E = 10.3 \times 10^6 \text{ lb/in}^2$ (aluminum) $I = 20 \text{ in}^4$</p> <p>solution</p> <p><i>Step 1.</i> Determine the distance (x).</p> $x = \frac{L}{6} = \frac{12 \text{ ft}}{6} = 2 \text{ ft}$ <p><i>Step 2.</i> Calculate the stiffness (EI).</p> $\begin{aligned} EI &= (10.3 \times 10^6 \text{ lb/in}^2)(20 \text{ in}^4) \\ &= \frac{2.06 \times 10^8 \text{ lb} \cdot \text{in}^2 \times 1 \text{ ft}^2}{144 \text{ in}^2} \\ &= 1.43 \times 10^6 \text{ lb} \cdot \text{ft}^2 \end{aligned}$	<p>Example 4. Calculate the deflection (Δ) of a simply-supported beam with a concentrated couple (C) a distance (x) of ($L/4$), where</p> <p>$C = 20 \text{ kN} \cdot \text{m} = 20,000 \text{ N} \cdot \text{m}$ $L = 4 \text{ m}, a = 1\frac{1}{2} \text{ m}, b = 2\frac{1}{2} \text{ m}$ $E = 71 \times 10^9 \text{ N/m}^2$ (aluminum) $I = 781 \text{ cm}^4$</p> <p>solution</p> <p><i>Step 1.</i> Determine the distance (x).</p> $x = \frac{L}{4} = \frac{4 \text{ m}}{4} = 1 \text{ m}$ <p><i>Step 2.</i> Calculate the stiffness (EI).</p> $\begin{aligned} EI &= (71 \times 10^9 \text{ N/m}^2)(781 \text{ cm}^4) \\ &\quad \times \frac{1 \text{ m}^4}{(100 \text{ cm})^4} \\ &= 5.54 \times 10^5 \text{ N} \cdot \text{m}^2 \end{aligned}$

U.S. Customary	SI/Metric
<p><i>Step 3.</i> Determine the deflection (Δ) from Eq. (2.16a).</p> $\Delta = \frac{Cx}{6(EI)L} [6aL - x^2 - 3a^2 - 2L^2]$ $= \frac{(15,000 \text{ ft} \cdot \text{lb})(2 \text{ ft})}{6(1.43 \times 10^6 \text{ lb} \cdot \text{ft}^2)(12 \text{ ft})}$ $\times [(6(4)(12) - (2)^2 - 3(4)^2 - 2(12)^2) \text{ ft}^2]$ $= \frac{(30,000 \text{ lb} \cdot \text{ft}^2)}{(1.03 \times 10^8 \text{ lb} \cdot \text{ft}^3)}$ $\times [(288 - 4 - 48 - 288) \text{ ft}^2]$ $= \left(2.9 \times 10^{-4} \frac{1}{\text{ft}}\right) \times [-52 \text{ ft}^2]$ $= -0.015 \text{ ft} \times \frac{12 \text{ in}}{\text{ft}} = -0.18 \text{ in} \downarrow$ $= 0.18 \text{ in} \uparrow$ <p>Example 5. Calculate the deflection (Δ_a) at the location (a) where the couple (C) acts, where</p> $C = 15 \text{ ft} \cdot \text{kip} = 15,000 \text{ ft} \cdot \text{lb}$ $L = 12 \text{ ft}, a = 4 \text{ ft}, b = 8 \text{ ft}$ $EI = 1.43 \times 10^6 \text{ lb} \cdot \text{ft}^2$ <p>solution</p> <p>Calculate the deflection (Δ_a) where the force (F) acts from Eq. (2.17).</p> $\Delta_a = \frac{Cab}{3(EI)L} (2a - L)$ $= \frac{(15,000 \text{ ft} \cdot \text{lb})(4 \text{ ft})(8 \text{ ft})}{3(1.43 \times 10^6 \text{ lb} \cdot \text{ft}^2)(12 \text{ ft})}$ $\times [2(4 \text{ ft}) - 12 \text{ ft}]$ $= \frac{4.8 \times 10^5 \text{ lb} \cdot \text{ft}^3}{5.15 \times 10^7 \text{ lb} \cdot \text{ft}^3} [8 \text{ ft} - 12 \text{ ft}]$ $= (9.32 \times 10^{-3})[-4 \text{ ft}]$ $= -0.037 \text{ ft} \times \frac{12 \text{ in}}{\text{ft}} = -0.45 \text{ in} \downarrow$ $= 0.45 \text{ in} \uparrow$	<p><i>Step 3.</i> Determine the deflection (Δ) from Eq. (2.16a).</p> $\Delta = \frac{Cx}{6(EI)L} [6aL - x^2 - 3a^2 - 2L^2]$ $= \frac{(20,000 \text{ N} \cdot \text{m})(1 \text{ m})}{6(5.54 \times 10^5 \text{ N} \cdot \text{m}^2)(4 \text{ m})}$ $\times [(6(1.5)(4) - (1)^2 - 3(1.5)^2 - 2(4)^2) \text{ ft}^2]$ $= \frac{(20,000 \text{ N} \cdot \text{m}^2)}{(1.33 \times 10^7 \text{ N} \cdot \text{m}^3)}$ $\times [(36 - 1 - 6.75 - 32) \text{ ft}^2]$ $= \left(1.5 \times 10^{-3} \frac{1}{\text{ft}}\right) \times [-3.75 \text{ ft}^2]$ $= -0.0056 \text{ m} \times \frac{100 \text{ cm}}{\text{m}} = -0.56 \text{ cm} \downarrow$ $= 0.56 \text{ cm} \uparrow$ <p>Example 5. Calculate the deflection (Δ_a) at the location (a) where the couple (C) acts, where</p> $C = 20 \text{ kN} \cdot \text{m} = 20,000 \text{ N} \cdot \text{m}$ $L = 4 \text{ m}, a = 1\frac{1}{2} \text{ m}, b = 2\frac{1}{2} \text{ m}$ $EI = 5.54 \times 10^5 \text{ N} \cdot \text{m}^2$ <p>solution</p> <p>Calculate the deflection (Δ_a) where the force (F) acts from Eq. (2.17).</p> $\Delta_a = \frac{Cab}{3(EI)L} (2a - L)$ $= \frac{(20,000 \text{ N} \cdot \text{m})(1.5 \text{ m})(2.5 \text{ m})}{3(5.54 \times 10^5 \text{ N} \cdot \text{m}^2)(4 \text{ m})}$ $\times [2(1.5 \text{ m}) - 4 \text{ m}]$ $= \frac{7.5 \times 10^4 \text{ N} \cdot \text{m}^3}{6.65 \times 10^6 \text{ N} \cdot \text{m}^3} [3 \text{ m} - 4 \text{ m}]$ $= (1.13 \times 10^{-2})[-1 \text{ m}]$ $= -0.0113 \text{ m} \times \frac{100 \text{ cm}}{\text{m}} = -1.13 \text{ cm} \downarrow$ $= 1.13 \text{ cm} \uparrow$

Notice that the deflection (Δ_a) came out as a negative value, which means it is above the axis of the beam where the couple (C) acts. As stated earlier, if the couple is located at the midpoint of the beam, then the deflection at this point is zero.

2.2.4 Uniform Load

The simply-supported beam shown in Fig. 2.30 has a uniform distributed load (w) acting vertically downward across the entire length of the beam (L). The units on this distributed load (w) are force per length. Therefore, the total force acting on the beam is the uniform load (w) times the length of the beam (L), that is, (wL).

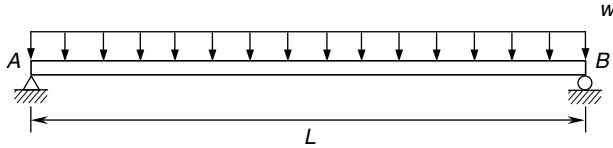

FIGURE 2.30 Uniform load.

Reactions. The reactions at the end supports are shown in Fig. 2.31, the balanced free-body-diagram. Notice that the total downward force (wL) is split evenly between the vertical reactions (A_y and B_y), and because the uniform load (w) is acting straight down, the horizontal reaction (A_x) is zero.

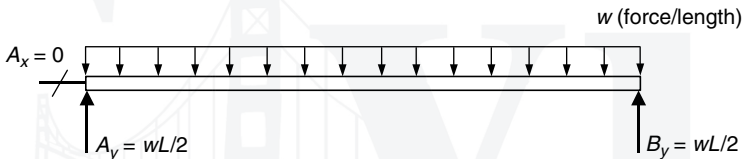

FIGURE 2.31 Free-body-diagram.

U.S. Customary	SI/Metric
<p>Example 1. Determine the reactions at the ends of a simply-supported beam of length (L) with a uniform load (w) acting across the entire beam, where</p> $w = 400 \text{ lb/ft}$ $L = 15 \text{ ft}$ <p>solution</p> <p><i>Step 1.</i> From Fig. 2.31 calculate the pin reactions (A_x and A_y) at the left end of the beam. As the uniform load (w) is vertical,</p> $A_x = 0$ <p>and with the uniform load (w) acting across the entire beam,</p> $A_y = \frac{wL}{2} = \frac{(400 \text{ lb/ft})(15 \text{ ft})}{2}$ $= \frac{6,000 \text{ lb}}{2} = 3,000 \text{ lb}$	<p>Example 1. Determine the reactions at the ends of a simply-supported beam of length (L) with a uniform load (w) acting across the entire beam, where</p> $w = 6,000 \text{ N/m}$ $L = 5 \text{ m}$ <p>solution</p> <p><i>Step 1.</i> From Fig. 2.31 calculate the pin reactions (A_x and A_y) at the left end of the beam. As the uniform load (w) is vertical,</p> $A_x = 0$ <p>and as the uniform load (w) acting across the entire beam,</p> $A_y = \frac{wL}{2} = \frac{(6,000 \text{ N/m})(5 \text{ m})}{2}$ $= \frac{30,000 \text{ N}}{2} = 15,000 \text{ N}$

U.S. Customary	SI/Metric
<p>Step 2. From Fig. 2.31 calculate the roller reaction (B_y) as</p> $B_y = \frac{wL}{2} = \frac{(400 \text{ lb/ft})(15 \text{ ft})}{2}$ $= \frac{6,000 \text{ lb}}{2} = 3,000 \text{ lb}$	<p>Step 2. From Fig. 2.31 calculate the roller reaction (B_y) as</p> $B_y = \frac{wL}{2} = \frac{(6,000 \text{ N/m})(5 \text{ m})}{2}$ $= \frac{30,000 \text{ N}}{2} = 15,000 \text{ N}$

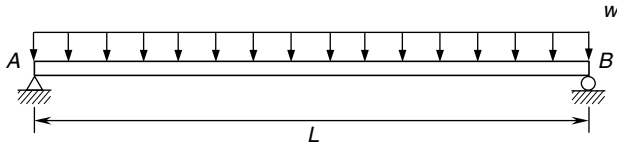

FIGURE 2.32 Concentrated force at midpoint.

Shear Force and Bending Moment Distributions. For the simply-supported beam with a uniformly distributed load (w) acting across the entire beam, shown in Fig. 2.32, which has the balanced free-body-diagram shown in Fig. 2.33, the shear force (V) distribution is shown in Fig. 2.34.

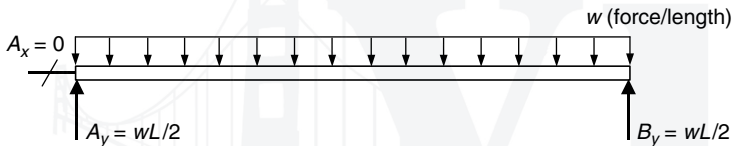

FIGURE 2.33 Free-body-diagram.

Note that the shear force (V) starts at a positive ($wL/2$) at the left end of the beam and decreases linearly to zero at the midpoint, continuing on to a negative ($wL/2$) at the right end of the beam. The shear force (V) is given by Eq. (2.18).

$$V = \frac{wL}{2} - wx \tag{2.18}$$

The maximum shear force (V_{\max}) is therefore given by Eq. (2.19).

$$V_{\max} = \frac{wL}{2} \quad \text{at } x = 0 \quad \text{and } x = L \tag{2.19}$$

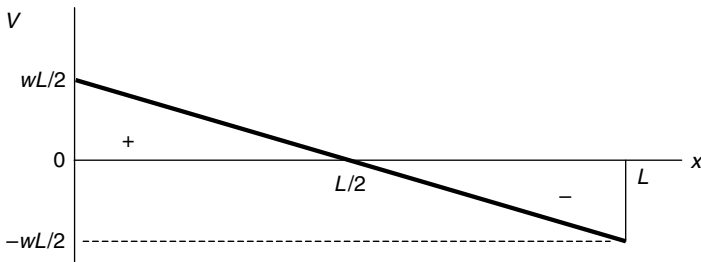

FIGURE 2.34 Shear force diagram.

The bending moment distribution is given by Eq. (2.20) for the values of the distance (x) from the left end of the beam. (Always measure the distance (x) from the left end of any beam, never from the right end.)

$$M = \frac{wx}{2}(L - x) \tag{2.20}$$

The bending moment (M) distribution is shown in Fig. 2.35.

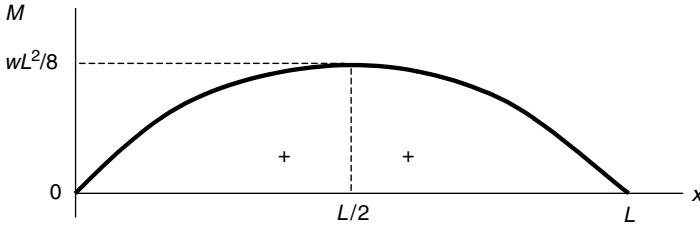

FIGURE 2.35 Bending moment diagram.

Note that the bending moment (M) is zero at both ends, and follows a parabolic curve to a maximum at the midpoint ($L/2$). From the midpoint, the bending moment decreases back to zero. The maximum bending moment (M_{\max}) is given by Eq. (2.21).

$$M_{\max} = \frac{wL^2}{8} \quad \text{at } x = \frac{L}{2} \tag{2.21}$$

U.S. Customary	SI/Metric
<p>Example 2. Calculate the shear force (V) and bending moment (M) at a distance (x) equal to ($L/3$) for a simply-supported beam of length (L) with a uniform load (w) across the entire beam, where</p> <p style="margin-left: 20px;">$w = 400 \text{ lb/ft}$ $L = 15 \text{ ft}$</p> <p>solution</p> <p><i>Step 1.</i> Establish the distance (x) from the left end of the beam, where</p> $x = \frac{L}{3} = \frac{15 \text{ ft}}{3} = 5 \text{ ft}$ <p><i>Step 2.</i> Determine the shear force (V) from Eq. (2.18) as</p> $\begin{aligned} V &= \frac{wL}{2} - wx \\ &= \frac{\left(400 \frac{\text{lb}}{\text{ft}}\right)(15 \text{ ft})}{2} - \left(400 \frac{\text{lb}}{\text{ft}}\right)(5 \text{ ft}) \\ &= \frac{6,000 \text{ lb}}{2} - 2,000 \text{ lb} \\ &= 3,000 \text{ lb} - 2,000 \text{ lb} \\ &= 1,000 \text{ lb} \end{aligned}$	<p>Example 2. Calculate the shear force (V) and bending moment (M) at a distance (x) equal to ($3L/10$) for a simply-supported beam of length (L) with a uniform load (w) across the entire beam, where</p> <p style="margin-left: 20px;">$w = 6,000 \text{ N/m}$ $L = 5 \text{ m}$</p> <p>solution</p> <p><i>Step 1.</i> Establish the distance (x) from the left end of the beam, where</p> $x = \frac{3L}{10} = \frac{3(5 \text{ m})}{10} = \frac{15 \text{ m}}{10} = 1.5 \text{ m}$ <p><i>Step 2.</i> Determine the shear force (V) from Fig. 2.18 as</p> $\begin{aligned} V &= \frac{wL}{2} - wx \\ &= \frac{\left(6,000 \frac{\text{N}}{\text{m}}\right)(5 \text{ m})}{2} - \left(6,000 \frac{\text{N}}{\text{m}}\right)(1.5 \text{ m}) \\ &= \frac{30,000 \text{ N}}{2} - 9,000 \text{ N} \\ &= 15,000 \text{ N} - 9,000 \text{ N} \\ &= 6,000 \text{ N} \end{aligned}$

U.S. Customary	SI/Metric
<p><i>Step 3.</i> Determine the bending moment (M) from Eq. (2.20).</p> $M = \frac{wx}{2}(L - x)$ $= \frac{\left(400 \frac{\text{lb}}{\text{ft}}\right)(5 \text{ ft})}{2}(15 \text{ ft} - 5 \text{ ft})$ $= \frac{2,000 \text{ lb}}{2}(10 \text{ ft})$ $= (1,000 \text{ lb})(10 \text{ ft}) = 10,000 \text{ ft} \cdot \text{lb}$ <p>Example 3. Calculate and locate the maximum shear force (V_{\max}) and the maximum bending moment (M_{\max}) for the beam of Examples 1 and 2, where</p> <p>$w = 400 \text{ lb/ft}$ $L = 15 \text{ ft}$</p> <p>solution</p> <p><i>Step 1.</i> Calculate the maximum shear force (V_{\max}) from Eq. (2.19) as</p> $V_{\max} = \frac{wL}{2} = \frac{(400 \text{ lb/ft})(15 \text{ ft})}{2}$ $= \frac{6,000 \text{ lb}}{2} = 3,000 \text{ lb}$ <p><i>Step 2.</i> From Fig. 2.34 this maximum shear force (V_{\max}) of 3,000 lb occurs at both the left and right ends of the beam.</p> <p><i>Step 3.</i> Calculate the maximum bending moment (M_{\max}) from Eq. (2.21) as</p> $M_{\max} = \frac{wL^2}{8} = \frac{(400 \text{ lb/ft})(15 \text{ ft})^2}{8}$ $= \frac{90,000 \text{ ft} \cdot \text{lb}}{8} = 11,250 \text{ ft} \cdot \text{lb}$ <p><i>Step 4.</i> As shown in Fig. 2.35 this maximum bending moment (M_{\max}) of 11,250 ft · lb is located at the midpoint of the beam.</p>	<p><i>Step 3.</i> Determine the bending moment (M) from Eq. (2.20).</p> $M = \frac{wx}{2}(L - x)$ $= \frac{\left(6,000 \frac{\text{N}}{\text{m}}\right)(1.5 \text{ m})}{2}(5 \text{ m} - 1.5 \text{ m})$ $= \frac{9,000 \text{ N}}{2}(3.5 \text{ m})$ $= (4,500 \text{ N})(3.5 \text{ m}) = 15,750 \text{ N} \cdot \text{m}$ <p>Example 3. Calculate and locate the maximum shear force (V_{\max}) and the maximum bending moment (M_{\max}) for the beam of Examples 1 and 2, where</p> <p>$w = 6,000 \text{ N/m}$ $L = 5 \text{ m}$</p> <p>solution</p> <p><i>Step 1.</i> Calculate the maximum shear force (V_{\max}) from Eq. (2.19) as</p> $V_{\max} = \frac{wL}{2} = \frac{(6,000 \text{ N/m})(5 \text{ m})}{2}$ $= \frac{30,000 \text{ N}}{2} = 15,000 \text{ N}$ <p><i>Step 2.</i> As shown in Fig. 2.34 this maximum shear force (V_{\max}) of 15,000 N occurs at both the left and right ends of the beam.</p> <p><i>Step 3.</i> Calculate the maximum bending moment (M_{\max}) from Eq. (2.21) as</p> $M_{\max} = \frac{wL^2}{8} = \frac{(6,000 \text{ N/m})(5 \text{ m})^2}{8}$ $= \frac{150,000 \text{ N} \cdot \text{m}}{8} = 18,750 \text{ N} \cdot \text{m}$ <p><i>Step 4.</i> As shown in Fig. 2.35 this maximum bending moment (M_{\max}) of 18,750 N · m is located at the midpoint of the beam.</p>

Deflection. For this loading configuration, the deflection (Δ) along the beam is shown in Fig. 2.36, and given by Eq. (2.22) for all values of the distance (x) from the left end of the beam,

$$\Delta = \frac{wx}{24EI}(L^3 - 2Lx^2 + x^3) \quad (2.22)$$

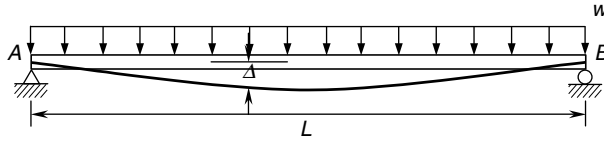

FIGURE 2.36 Beam deflection diagram.

where Δ = deflection of beam (positive downward)

w = applied uniform load

x = distance from left end of beam

L = length of beam

E = modulus of elasticity of beam material

I = area moment of inertia of cross-sectional area about axis through centroid

The maximum deflection (Δ_{\max}) caused by this loading configuration is given by Eq. (2.23),

$$\Delta_{\max} = \frac{5 w L^4}{384 E I} \quad \text{at } x = \frac{L}{2} \quad (2.23)$$

located at the midpoint ($L/2$).

U.S. Customary	SI/Metric
<p>Example 4. Calculate the deflection (Δ) at a distance (x) equal to $(2L/3)$ for a simply-supported beam of length (L) with a uniform load (w) across the entire beam, where</p> <p>$w = 400 \text{ lb/ft}$ $L = 15 \text{ ft}$ $E = 10.3 \times 10^6 \text{ lb/in}^2$ (aluminum) $I = 12 \text{ in}^4$</p> <p>solution</p> <p><i>Step 1.</i> Determine the distance (x).</p> $x = \frac{2L}{3} = \frac{2(15 \text{ ft})}{3} = \frac{30 \text{ ft}}{3} = 10 \text{ ft}$ <p><i>Step 2.</i> Calculate the stiffness (EI).</p> $\begin{aligned} EI &= (10.3 \times 10^6 \text{ lb/in}^2)(12 \text{ in}^4) \\ &= 1.24 \times 10^8 \text{ lb} \cdot \text{in}^2 \times \frac{1 \text{ ft}^2}{144 \text{ in}^2} \\ &= 8.58 \times 10^5 \text{ lb} \cdot \text{ft}^2 \end{aligned}$	<p>Example 4. Calculate the deflection (Δ) at a distance (x) equal to $(3L/5)$ for a simply-supported beam of length (L) with a uniform load (w) across the entire beam, where</p> <p>$w = 6,000 \text{ N/m}$ $L = 5 \text{ m}$ $E = 71 \times 10^9 \text{ N/m}^2$ (aluminum) $I = 469 \text{ cm}^4$</p> <p>solution</p> <p><i>Step 1.</i> Determine the distance (x).</p> $x = \frac{3L}{5} = \frac{3(5 \text{ m})}{5} = \frac{15 \text{ m}}{5} = 3 \text{ m}$ <p><i>Step 2.</i> Calculate the stiffness (EI).</p> $\begin{aligned} EI &= (71 \times 10^9 \text{ N/m}^2)(469 \text{ cm}^4) \\ &\quad \times \frac{1 \text{ m}^4}{(100 \text{ cm})^4} \\ &= 3.33 \times 10^5 \text{ N} \cdot \text{m}^2 \end{aligned}$

U.S. Customary	SI/Metric
<p><i>Step 3.</i> Determine the deflection (Δ) from Eq. (2.22).</p> $\begin{aligned}\Delta &= \frac{wx}{24(EI)}(L^3 - 2Lx^2 + x^3) \\ &= \frac{(400 \text{ lb/ft})(10 \text{ ft})}{24(8.58 \times 10^5 \text{ lb} \cdot \text{ft}^2)} \\ &\quad \times [(15 \text{ ft})^3 - 2(15 \text{ ft})(10 \text{ ft})^2 + (10 \text{ ft})^3] \\ &= \frac{(4,000 \text{ lb})}{(2.06 \times 10^7 \text{ lb} \cdot \text{ft}^2)} \\ &\quad \times [(3,375) - (3,000) + (1,000) \text{ ft}^3] \\ &= \left(1.94 \times 10^{-4} \frac{1}{\text{ft}^2}\right) \times [1,375 \text{ ft}^3] \\ &= 0.27 \text{ ft} \times \frac{12 \text{ in}}{\text{ft}} = 3.2 \text{ in} \downarrow\end{aligned}$ <p>Example 5. Calculate the maximum deflection (Δ_{\max}) and its location for the beam configuration in Example 4, where</p> <p>$w = 400 \text{ lb/ft}$ $L = 15 \text{ ft}$ $EI = 8.58 \times 10^5 \text{ lb} \cdot \text{ft}^2$</p> <p>solution</p> <p><i>Step 1.</i> Calculate the maximum deflection from Eq. (2.23).</p> $\begin{aligned}\Delta_{\max} &= \frac{5wL^4}{384(EI)} \\ &= \frac{5(400 \text{ lb/ft})(15 \text{ ft})^4}{384(8.58 \times 10^5 \text{ lb} \cdot \text{ft}^2)} \\ &= \frac{1.0125 \times 10^8 \text{ lb} \cdot \text{ft}^3}{3.2947 \times 10^8 \text{ lb} \cdot \text{ft}^2} \\ &= 0.31 \text{ ft} \times \frac{12 \text{ in}}{\text{ft}} = 3.7 \text{ in} \downarrow\end{aligned}$ <p>The location of this maximum deflection is at the midpoint of the beam, ($L/2$).</p>	<p><i>Step 3.</i> Determine the deflection (Δ) from Eq. (2.22).</p> $\begin{aligned}\Delta &= \frac{wx}{24(EI)}(L^3 - 2Lx^2 + x^3) \\ &= \frac{(6,000 \text{ N/m})(3 \text{ m})}{24(3.33 \times 10^5 \text{ N} \cdot \text{m}^2)} \\ &\quad \times [(5 \text{ m})^3 - 2(5 \text{ m})(3 \text{ m})^2 + (3 \text{ m})^3] \\ &= \frac{(18,000 \text{ N})}{(8.00 \times 10^6 \text{ N} \cdot \text{m}^2)} \\ &\quad \times [(125) - (90) + (27) \text{ ft}^3] \\ &= \left(2.25 \times 10^{-3} \frac{1}{\text{m}^2}\right) \times [62 \text{ m}^3] \\ &= 0.14 \text{ m} \times \frac{100 \text{ cm}}{\text{m}} = 14.0 \text{ cm} \downarrow\end{aligned}$ <p>Example 5. Calculate the maximum deflection (Δ_{\max}) and its location for the beam configuration in Example 4, where</p> <p>$w = 6,000 \text{ N/m}$ $L = 5 \text{ m}$ $EI = 3.33 \times 10^5 \text{ N} \cdot \text{m}^2$</p> <p>solution</p> <p><i>Step 1.</i> Calculate the maximum deflection from Eq. (2.23).</p> $\begin{aligned}\Delta_{\max} &= \frac{5wL^4}{384(EI)} \\ &= \frac{5(6,000 \text{ N/m})(5 \text{ m})^4}{384(3.33 \times 10^5 \text{ N} \cdot \text{m}^2)} \\ &= \frac{1.875 \times 10^7 \text{ N} \cdot \text{m}^3}{1.279 \times 10^8 \text{ N} \cdot \text{m}^2} \\ &= 0.147 \text{ m} \times \frac{100 \text{ cm}}{\text{m}} = 14.7 \text{ cm} \downarrow\end{aligned}$ <p>The location of this maximum deflection is at the midpoint of the beam, ($L/2$).</p>

2.2.5 Triangular Load

The simply-supported beam shown in Fig. 2.37 has a triangular distributed load acting vertically downward across the length of the beam (L), where the magnitude of the distributed load is zero at the left pin support and increases linearly to a magnitude (w) at the right roller support. The units on the distributed load (w) are force per length. Therefore, the total force acting on the beam is the area under this triangle, which is the distributed load (w) times the length of the beam (L) divided by two, that is ($wL/2$).

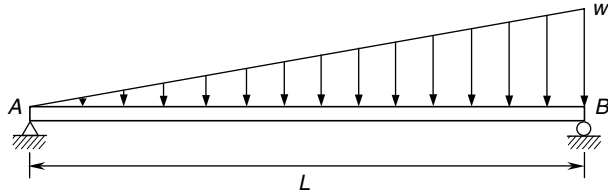

FIGURE 2.37 Triangular load.

Reactions. The reactions at the end supports are shown in Fig. 2.38, the balanced free-body-diagram. The total force ($wL/2$) is split unevenly between the vertical reactions (A_y and B_y), with the right reaction twice the left. As the triangular load (w) is acting straight down, the horizontal reaction (A_x) is zero.

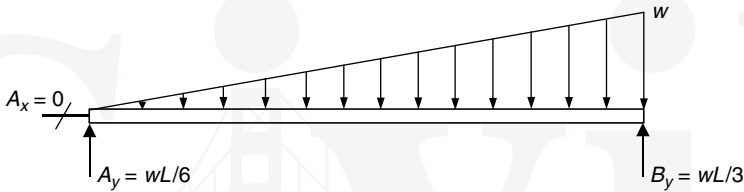

FIGURE 2.38 Free-body-diagram.

U.S. Customary	SI/Metric
<p>Example 1. Determine the reactions at the ends of a simply-supported beam of length (L) with a triangular load (w) acting across the beam, where</p> $w = 750 \text{ lb/ft}$ $L = 6 \text{ ft}$ <p>solution</p> <p><i>Step 1.</i> From Fig. 2.38 calculate the pin reactions (A_x and A_y) at the left end of the beam. As the triangular load (w) is vertical,</p> $A_x = 0$ <p>and with the triangular load (w) acting from left to right across the beam,</p> $A_y = \frac{wL}{6} = \frac{(750 \text{ lb/ft})(6 \text{ ft})}{6}$ $= \frac{4,500 \text{ lb}}{6} = 750 \text{ lb}$	<p>Example 1. Determine the reactions at the ends of a simply-supported beam of length (L) with a triangular load (w) acting across the beam, where</p> $w = 10,000 \text{ N/m}$ $L = 1.8 \text{ m}$ <p>solution</p> <p><i>Step 1.</i> From Fig. 2.38 calculate the pin reactions (A_x and A_y) at the left end of the beam. As the triangular load (w) is vertical,</p> $A_x = 0$ <p>and with the triangular load (w) acting from left to right across the beam,</p> $A_y = \frac{wL}{6} = \frac{(10,000 \text{ N/m})(1.8 \text{ m})}{6}$ $= \frac{18,000 \text{ N}}{6} = 3,000 \text{ N}$

U.S. Customary	SI/Metric
<p><i>Step 2.</i> From Fig. 2.38 calculate the roller reaction (B_y) as</p> $B_y = \frac{wL}{3} = \frac{(750 \text{ lb/ft})(6 \text{ ft})}{3}$ $= \frac{4,500 \text{ lb}}{3} = 1,500 \text{ lb}$	<p><i>Step 2.</i> From Fig. 2.38 calculate the roller reaction (B_y) as</p> $B_y = \frac{wL}{3} = \frac{(10,000 \text{ N/m})(1.8 \text{ m})}{3}$ $= \frac{18,000 \text{ lb}}{3} = 6,000 \text{ N}$

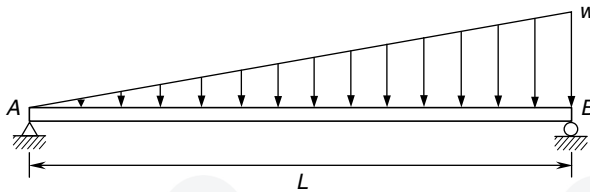

FIGURE 2.39 Concentrated force at midpoint.

Shear Force and Bending Moment Distributions. For the simply-supported beam with a triangular distributed load (w) acting from left to right across the beam shown in Fig. 2.39, which has the balanced free-body-diagram shown in Fig. 2.40, the shear force (V) distribution is shown in Fig. 2.41.

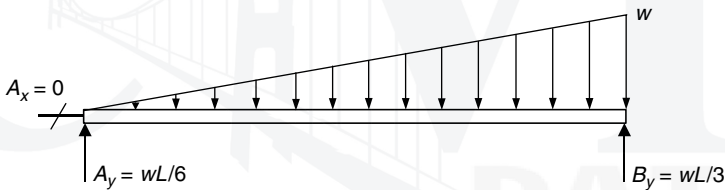

FIGURE 2.40 Free-body-diagram.

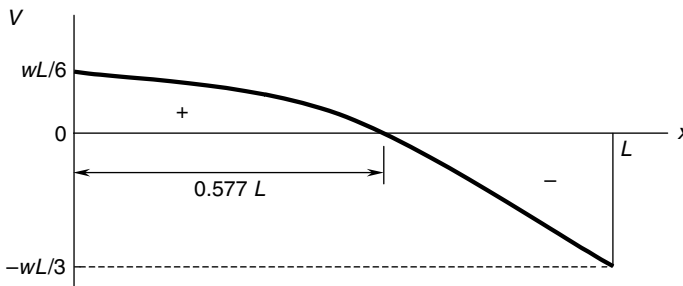

FIGURE 2.41 Shear force diagram.

The shear force (V) starts at a positive ($wL/6$) at the left end of the beam and decreases to zero at the point ($0.577 L$), continuing on to a negative ($wL/3$) at the right end of the beam.

The shear force (V) is given by Eq. (2.24)

$$V = \frac{wL}{6} \left[1 - 3\left(\frac{x}{L}\right)^2 \right] \quad (2.24)$$

The maximum shear force (V_{\max}) is therefore given by Eq. (2.25)

$$V_{\max} = \frac{wL}{3} \quad \text{at } x = L \quad (2.25)$$

The bending moment distribution is given by Eq. (2.26) for the values of the distance (x) from the left end of the beam.

$$M = \frac{wLx}{6} \left[1 - \left(\frac{x}{L}\right)^2 \right] \quad \text{at } x = \frac{L}{\sqrt{3}} = 0.577 L \quad (2.26)$$

The bending moment (M) distribution is shown in Fig. 2.42.

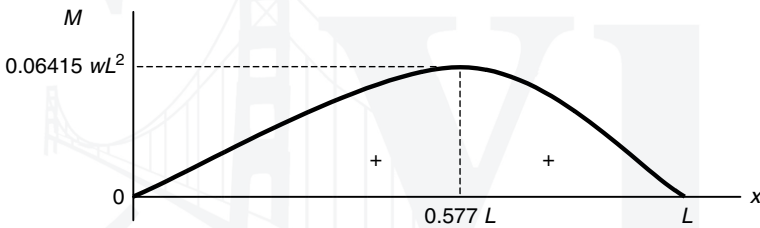

FIGURE 2.42 Bending moment diagram.

The bending moment (M) is zero at both ends, and follows a parabolic curve to a maximum at the point ($0.577 L$), then decreases back to zero. The maximum bending moment (M_{\max}) is given by Eq. (2.27)

$$M_{\max} = \frac{wL^2}{9\sqrt{3}} = 0.06415 wL^2 \quad \text{at } x = 0.577 L \quad (2.27)$$

U.S. Customary	SI/Metric
<p>Example 2. Calculate the shear force (V) and bending moment (M) at a distance (x) equal to ($L/3$) for a simply-supported beam of length (L) with a triangular load (w) across the beam, where</p> <p>$w = 750$ lb/ft</p> <p>$L = 6$ ft</p>	<p>Example 2. Calculate the shear force (V) and bending moment (M) at a distance (x) equal to ($L/3$) for a simply-supported beam of length (L) with a triangular load (w) across the beam, where</p> <p>$w = 10,000$ N/m</p> <p>$L = 1.8$ m</p>

U.S. Customary	SI/Metric
<p>solution</p> <p><i>Step 1.</i> Establish the distance (x) from the left end of the beam, where</p> $x = \frac{L}{3} = \frac{6 \text{ ft}}{3} = 2 \text{ ft}$ <p><i>Step 2.</i> Determine the shear force (V) from Eq. (2.24) as</p> $\begin{aligned} V &= \frac{wL}{6} \left[1 - 3 \left(\frac{x}{L} \right)^2 \right] \\ &= \frac{\left(750 \frac{\text{lb}}{\text{ft}} \right) (6 \text{ ft})}{6} \left[1 - 3 \left(\frac{2 \text{ ft}}{6 \text{ ft}} \right)^2 \right] \\ &= \frac{4,500 \text{ lb}}{6} [1 - 0.333] \\ &= (750 \text{ lb})(0.677) \\ &= 500 \text{ lb} \end{aligned}$ <p><i>Step 3.</i> Determine the bending moment (M) from Eq. (2.26).</p> $\begin{aligned} M &= \frac{wLx}{6} \left[1 - \left(\frac{x}{L} \right)^2 \right] \\ &= \frac{\left(750 \frac{\text{lb}}{\text{ft}} \right) (6 \text{ ft})(2 \text{ ft})}{6} \left[1 - \left(\frac{2 \text{ ft}}{6 \text{ ft}} \right)^2 \right] \\ &= \frac{9,000 \text{ ft} \cdot \text{lb}}{6} [1 - 0.111] \\ &= (1,500 \text{ ft} \cdot \text{lb})(0.889) \\ &= 1,333 \text{ ft} \cdot \text{lb} \end{aligned}$	<p>solution</p> <p><i>Step 1.</i> Establish the distance (x) from the left end of the beam, where</p> $x = \frac{L}{3} = \frac{1.8 \text{ m}}{3} = 0.6 \text{ m}$ <p><i>Step 2.</i> Determine the shear force (V) from Eq. (2.24) as</p> $\begin{aligned} V &= \frac{wL}{6} \left[1 - 3 \left(\frac{x}{L} \right)^2 \right] \\ &= \frac{\left(10,000 \frac{\text{N}}{\text{m}} \right) (1.8 \text{ m})}{6} \left[1 - 3 \left(\frac{0.6 \text{ m}}{1.8 \text{ m}} \right)^2 \right] \\ &= \frac{18,000 \text{ N}}{6} [1 - 0.333] \\ &= (3,000 \text{ N})(0.677) \\ &= 2,000 \text{ N} \end{aligned}$ <p><i>Step 3.</i> Determine the bending moment (M) from Eq. (2.26).</p> $\begin{aligned} M &= \frac{wLx}{6} \left[1 - \left(\frac{x}{L} \right)^2 \right] \\ &= \frac{\left(10,000 \frac{\text{N}}{\text{m}} \right) (1.8 \text{ m})(0.6 \text{ m})}{6} \left[1 - \left(\frac{0.6 \text{ m}}{1.8 \text{ m}} \right)^2 \right] \\ &= \frac{10,800 \text{ N} \cdot \text{m}}{6} [1 - 0.111] \\ &= (1,800 \text{ N} \cdot \text{m})(0.889) \\ &= 1,600 \text{ N} \cdot \text{m} \end{aligned}$
<p>Example 3. Calculate and locate the maximum shear force (V_{\max}) and the maximum bending moment (M_{\max}) for the beam of Examples 1 and 2, where</p> $\begin{aligned} w &= 750 \text{ lb/ft} \\ L &= 6 \text{ ft} \end{aligned}$ <p>solution</p> <p><i>Step 1.</i> Calculate the maximum shear force (V_{\max}) from Eq. (2.25) as</p> $\begin{aligned} V_{\max} &= \frac{wL}{3} = \frac{(750 \text{ lb/ft})(6 \text{ ft})}{3} \\ &= \frac{4,500 \text{ lb}}{3} = 1,500 \text{ lb} \end{aligned}$ <p><i>Step 2.</i> Figure 2.41 shows that this maximum shear force (V_{\max}) of 1,500 lb occurs at the right end of the beam.</p>	<p>Example 3. Calculate and locate the maximum shear force (V_{\max}) and the maximum bending moment (M_{\max}) for the beam of Examples 1 and 2, where</p> $\begin{aligned} w &= 10,000 \text{ N/m} \\ L &= 1.8 \text{ m} \end{aligned}$ <p>solution</p> <p><i>Step 1.</i> Calculate the maximum shear force (V_{\max}) from Eq. (2.25) as</p> $\begin{aligned} V_{\max} &= \frac{wL}{3} = \frac{(10,000 \text{ N/m})(1.8 \text{ m})}{3} \\ &= \frac{18,000 \text{ N}}{3} = 6,000 \text{ N} \end{aligned}$ <p><i>Step 2.</i> Figure 2.41 shows that this maximum shear force (V_{\max}) of 6,000 N occurs at the right end of the beam.</p>

U.S. Customary	SI/Metric
<p><i>Step 3.</i> Calculate the maximum bending moment (M_{\max}) from Eq. (2.27) as</p> $M_{\max} = \frac{wL^2}{9\sqrt{3}} = \frac{(750 \text{ lb/ft})(6 \text{ ft})^2}{9\sqrt{3}}$ $= \frac{27,000 \text{ ft} \cdot \text{lb}}{15.59} = 1,732 \text{ ft} \cdot \text{lb}$ <p><i>Step 4.</i> Figure 2.42 shows that this maximum bending moment (M_{\max}) of 1,732 ft · lb is located at</p> $x = \frac{L}{\sqrt{3}} = 0.577 L$ $= 0.577 (6 \text{ ft}) = 3.46 \text{ ft} > \frac{L}{2}$ <p>from the left end of the beam.</p>	<p><i>Step 3.</i> Calculate the maximum bending moment (M_{\max}) from Eq. (2.27) as</p> $M_{\max} = \frac{wL^2}{9\sqrt{3}} = \frac{(10,000 \text{ N/m})(1.8 \text{ m})^2}{9\sqrt{3}}$ $= \frac{32,400 \text{ N} \cdot \text{m}}{15.59} = 2,078 \text{ N} \cdot \text{m}$ <p><i>Step 4.</i> Figure 2.42 shows that this maximum bending moment (M_{\max}) of 2,078 N · m is located at</p> $x = \frac{L}{\sqrt{3}} = 0.577 L$ $= 0.577 (1.8 \text{ m}) = 1.04 \text{ m} > \frac{L}{2}$ <p>from the left end of the beam.</p>

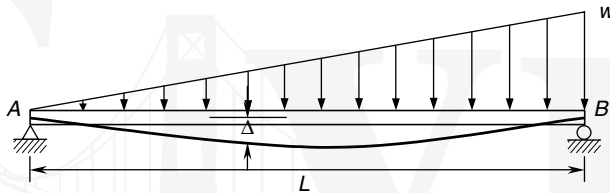

FIGURE 2.43 Beam deflection diagram.

Deflection. For this loading configuration, the deflection (Δ) along the beam is shown in Fig. 2.43, and given by Eq. (2.28) for values of the distance (x) from the left end of the beam,

$$\Delta = \frac{wx}{360 EIL} (7L^4 - 10L^2x^2 + 3x^4) \quad (2.28)$$

where Δ = deflection of beam (positive downward)

w = applied triangular load

x = distance from left end of beam

L = length of beam

E = modulus of elasticity of beam material

I = area moment of inertia of cross-sectional area about axis through centroid

The maximum deflection (Δ_{\max}) caused by this loading configuration is given by Eq. (2.29),

$$\Delta_{\max} = 0.00652 \frac{wL^4}{EI} \quad \text{at } x = \left(\sqrt{1 - \sqrt{8/15}} \right) L \approx (0.52) L \quad (2.29)$$

located at the point (approximately $0.52 L$) from the left end of the beam.

U.S. Customary	SI/Metric
<p>Example 4. Calculate the deflection (Δ) at a distance (x) equal to $(L/2)$ for a simply-supported beam of length (L) with a triangular load (w) from left to right across the beam, where</p> <p>$w = 750 \text{ lb/ft}$ $L = 6 \text{ ft}$ $E = 30 \times 10^6 \text{ lb/in}^2 \text{ (steel)}$ $I = 28 \text{ in}^4$</p> <p>solution</p> <p><i>Step 1.</i> Determine the distance (x).</p> $x = \frac{L}{2} = \frac{6 \text{ ft}}{2} = 3 \text{ ft}$ <p><i>Step 2.</i> Calculate the stiffness (EI).</p> $\begin{aligned} EI &= (30 \times 10^6 \text{ lb/in}^2)(28 \text{ in}^4) \\ &= \frac{8.40 \times 10^8 \text{ lb} \cdot \text{in}^2 \times 1 \text{ ft}^2}{144 \text{ in}^2} \\ &= 5.83 \times 10^6 \text{ lb} \cdot \text{ft}^2 \end{aligned}$ <p><i>Step 3.</i> Determine the deflection (Δ) from Eq. (2.28).</p> $\begin{aligned} \Delta &= \frac{wx}{360(EI)L} (7L^4 - 10L^2x^2 + 3x^4) \\ &= \frac{(750 \text{ lb/ft})(3 \text{ ft})}{360(5.83 \times 10^6 \text{ lb} \cdot \text{ft}^2)(6 \text{ ft})} \\ &\quad \times [7(6 \text{ ft})^4 - 10(6 \text{ ft})^2(3 \text{ ft})^2 + 3(3 \text{ ft})^4] \\ &= \frac{(2,250 \text{ lb})}{(1.26 \times 10^{10} \text{ lb} \cdot \text{ft}^3)} \\ &\quad \times [(9,072) - (3,240) + (243) \text{ ft}^4] \\ &= \left(1.79 \times 10^{-7} \frac{1}{\text{ft}^3}\right) \times [6,075 \text{ ft}^4] \\ &= 0.001085 \text{ ft} \times \frac{12 \text{ in}}{\text{ft}} = 0.0130 \text{ in} \downarrow \end{aligned}$ <p>Example 5. Calculate the maximum deflection (Δ_{\max}) and its location for the beam configuration in Example 4, where</p> <p>$w = 750 \text{ lb/ft}$ $L = 6 \text{ ft}$ $EI = 5.83 \times 10^6 \text{ lb} \cdot \text{ft}^2$</p>	<p>Example 4. Calculate the deflection (Δ) at a distance (x) equal to $(L/2)$ for a simply-supported beam of length (L) with a triangular load (w) from left to right across the beam, where</p> <p>$w = 10,000 \text{ N/m}$ $L = 1.8 \text{ m}$ $E = 207 \times 10^9 \text{ N/m}^2 \text{ (steel)}$ $I = 1,098 \text{ cm}^4$</p> <p>solution</p> <p><i>Step 1.</i> Determine the distance (x).</p> $x = \frac{L}{2} = \frac{1.8 \text{ m}}{2} = 0.9 \text{ m}$ <p><i>Step 2.</i> Calculate the stiffness (EI).</p> $\begin{aligned} EI &= (207 \times 10^9 \text{ N/m}^2)(1,098 \text{ cm}^4) \\ &\quad \times \frac{1 \text{ m}^4}{(100 \text{ cm})^4} \\ &= 2.27 \times 10^6 \text{ N} \cdot \text{m}^2 \end{aligned}$ <p><i>Step 3.</i> Determine the deflection (Δ) from Eq. (2.28).</p> $\begin{aligned} \Delta &= \frac{wx}{360(EI)L} (7L^4 - 10L^2x^2 + 3x^4) \\ &= \frac{(10,000 \text{ N/m})(0.9 \text{ m})}{360(2.27 \times 10^6 \text{ N} \cdot \text{m}^2)(1.8 \text{ m})} \\ &\quad \times [7(1.8 \text{ m})^4 - 10(1.8 \text{ m})^2(0.9 \text{ m})^2 \\ &\quad + 3(0.9 \text{ m})^4] \\ &= \frac{(9,000 \text{ N})}{(1.47 \times 10^9 \text{ N} \cdot \text{m}^3)} \\ &\quad \times [(73.48) - (26.24) + (1.97) \text{ m}^4] \\ &= \left(6.11 \times 10^{-6} \frac{1}{\text{m}^3}\right) \times [49.21 \text{ m}^4] \\ &= 0.000301 \text{ m} \times \frac{100 \text{ cm}}{\text{m}} = 0.0301 \text{ cm} \downarrow \end{aligned}$ <p>Example 5. Calculate the maximum deflection (Δ_{\max}) and its location for the beam configuration in Example 4, where</p> <p>$w = 10,000 \text{ N/m}$ $L = 1.8 \text{ m}$ $EI = 2.27 \times 10^6 \text{ N} \cdot \text{m}^2$</p>

U.S. Customary	SI/Metric
<p>solution <i>Step 1.</i> Calculate the maximum deflection from Eq. (2.29).</p> $\Delta_{\max} = 0.00652 \frac{wL^4}{(EI)}$ $= (0.00652) \frac{(750 \text{ lb/ft})(6 \text{ ft})^4}{(5.83 \times 10^6 \text{ lb} \cdot \text{ft}^2)}$ $= (0.00652) \frac{9.72 \times 10^5 \text{ lb} \cdot \text{ft}^3}{5.83 \times 10^6 \text{ lb} \cdot \text{ft}^2}$ $= (0.00652)(0.1667 \text{ ft})$ $= 0.00109 \text{ ft} \times \frac{12 \text{ in}}{\text{ft}} = 0.013 \text{ in} \downarrow$ <p>The location of this maximum deflection occurs just to the right of the midpoint of the beam, approximately at (0.52 L).</p> $x_{\Delta_{\max}} = 0.52 L = (0.52)(6 \text{ ft}) = 3.12 \text{ ft}$	<p>solution <i>Step 1.</i> Calculate the maximum deflection from Eq. (2.29).</p> $\Delta_{\max} = 0.00652 \frac{wL^4}{(EI)}$ $= (0.00652) \frac{(10,000 \text{ N/m})(1.8 \text{ m})^4}{(2.27 \times 10^6 \text{ N} \cdot \text{m}^2)}$ $= (0.00652) \frac{1.05 \times 10^5 \text{ N} \cdot \text{m}^3}{2.27 \times 10^6 \text{ N} \cdot \text{m}^2}$ $= (0.00652)(0.0462 \text{ m})$ $= 0.0003 \text{ m} \times \frac{100 \text{ cm}}{\text{m}} = 0.030 \text{ cm} \downarrow$ <p>The location of this maximum deflection occurs just to the right of the midpoint of the beam, approximately at (0.52 L).</p> $x_{\Delta_{\max}} = 0.52 L = (0.52)(1.8 \text{ m}) = 0.94 \text{ m}$

2.2.6 Twin Concentrated Forces

The simply-supported beam in Fig. 2.44 has twin concentrated forces, each of magnitude (F), acting directly downward and located equidistant from each end of the beam. The distance these two forces are from each support is labeled (a), and the distance between the supports is labeled (L). Therefore, the distance between the two concentrated forces is a distance ($L - 2a$).

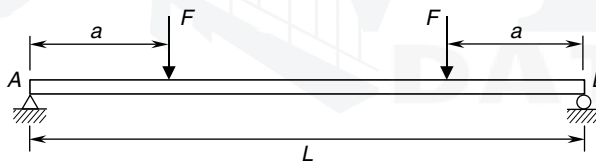

FIGURE 2.44 Twin concentrated forces.

Reactions. The reactions at the end supports are shown in Fig. 2.45—the balanced free-body diagram. The vertical reactions (A_y and B_y) are equal, each with magnitude (F). As both forces are acting directly downward, the horizontal reaction (A_x) is zero.

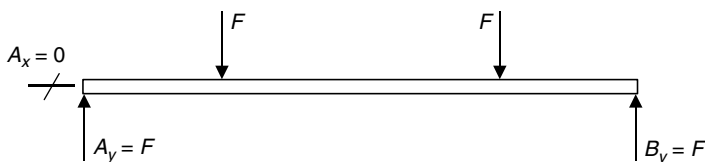

FIGURE 2.45 Free-body diagram.

U.S. Customary	SI/Metric
<p>Example 1. Determine the reactions at the ends of a simply-supported beam of length (L) with twin concentrated forces, both of magnitude (F) and located equidistant from the supports, where</p> <p>$F = 1,000$ lb $L = 5$ ft, $a = 1$ ft</p> <p>solution</p> <p><i>Step 1.</i> From Fig. 2.45 calculate the pin reactions (A_x and A_y) at the left end of the beam. As the forces are acting directly downward,</p> $A_x = 0$ <p>and the vertical reaction (A_y) is</p> $A_y = F = 1,000$ lb <p><i>Step 2.</i> From Fig. 2.45 calculate the roller reaction (B_y) at the right end of the beam.</p> $B_y = F = 1,000$ lb	<p>Example 1. Determine the reactions at the ends of a simply-supported beam of length (L) with twin concentrated forces, both of magnitude (F) and located equidistant from the supports, where</p> <p>$F = 4,500$ N $L = 1.5$ m, $a = 0.3$ m</p> <p>solution</p> <p><i>Step 1.</i> From Fig. 2.45 calculate the pin reactions (A_x and A_y) at the left end of the beam. As the forces are acting directly downward,</p> $A_x = 0$ <p>and the vertical reaction (A_y) is</p> $A_y = F = 4,500$ N <p><i>Step 2.</i> From Fig. 2.45 calculate the roller reaction (B_y) at the right end of the beam.</p> $B_y = F = 4,500$ N

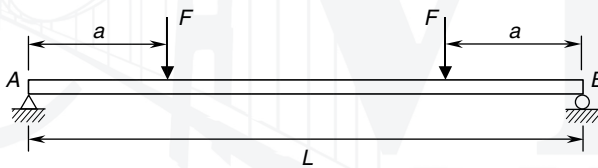

FIGURE 2.46 Twin concentrated forces.

Shear Force and Bending Moment Distributions. For the simply-supported beam with twin concentrated forces, each of magnitude (F), and located equidistant from the supports, shown in Fig. 2.46, which has the balanced free-body-diagram shown in Fig. 2.47, the shear force (V) distribution is shown in Fig. 2.48.

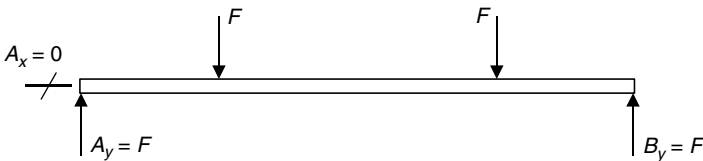

FIGURE 2.47 Free-body-diagram.

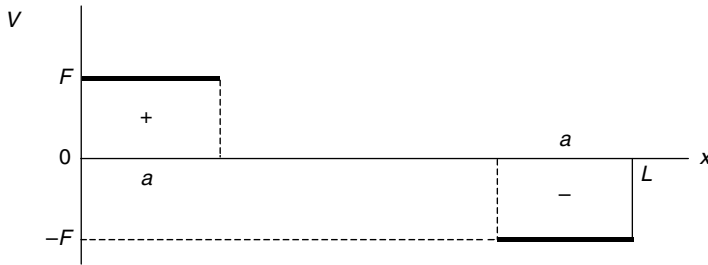

FIGURE 2.48 Shear force diagram.

Note that the shear force (V) is a positive (F) from the left end of the beam to the first of the twin concentrated forces, zero between the forces, then a negative (F) from the second twin force to the right end of the beam. Therefore, the maximum shear force (V_{\max}) is given by Eq. (2.30)

$$V_{\max} = F \quad (2.30)$$

The bending moment (M) distribution is given by Eq. (2.31a) for all values of the distance (x) from the left end of the beam to where the first of the twin forces acts, Eq. (2.31b) between the forces, and Eq. (2.31c) from the second twin force to the right end of the beam. (Always measure the distance (x) from the left end of any beam.)

$$M = Fx \quad 0 \leq x \leq a \quad (2.31a)$$

$$M = Fa \quad a \leq x \leq L - a \quad (2.31b)$$

$$M = F(L - x) \quad L - a \leq x \leq L \quad (2.31c)$$

The bending moment (M) distribution is shown in Fig. 2.49.



FIGURE 2.49 Bending moment diagram.

Note that the bending moment (M) increases linearly from zero at the left end of the beam to a value (Fa) at the first of the twin forces, stays a constant (Fa) between the forces, and then decreases linearly back to zero at the right end.

The maximum bending moment (M_{\max}) occurs between the twin forces and is given by Eq. (2.32).

$$M_{\max} = Fa \quad (2.32)$$

U.S. Customary	SI/Metric
<p>Example 2. Calculate the shear force (V) and bending moment (M) for a simply-supported beam of length (L) with twin concentrated forces, both of magnitude (F) and located equidistant from the supports, at a distance (x), where</p> $F = 1,000 \text{ lb}$ $L = 5 \text{ ft}, a = 1 \text{ ft}$ $x = 2 \text{ ft}$ <p>solution</p> <p><i>Step 1.</i> Note that the distance (x) of 2 ft is between the two forces.</p> $a \leq x \leq L - a \quad \text{or} \quad 1 \text{ ft} \leq 2 \text{ ft} \leq 4 \text{ ft}$ <p><i>Step 2.</i> Determine the shear force (V) for the distance (x) from Fig. 2.48 as</p> $V = 0$ <p><i>Step 3.</i> Determine the bending moment (M) for the distance (x) from Eq. (2.31b).</p> $M = Fa = (1,000 \text{ lb})(1 \text{ ft})$ $= 1,000 \text{ ft} \cdot \text{lb}$	<p>Example 2. Calculate the shear force (V) and bending moment (M) for a simply-supported beam of length (L) with twin concentrated forces, both of magnitude (F) and located equidistant from the supports, at a distance (x), where</p> $F = 4,500 \text{ N}$ $L = 1.5 \text{ m}, a = 0.3 \text{ m}$ $x = 0.5 \text{ m}$ <p>solution</p> <p><i>Step 1.</i> Note that the distance (x) of 0.5 m is between the two forces.</p> $a \leq x \leq L - a \quad \text{or} \quad 0.3 \text{ m} \leq 0.5 \text{ m} \leq 1.2 \text{ m}$ <p><i>Step 2.</i> Determine the shear force (V) for the distance (x) from Fig. 2.48 as</p> $V = 0$ <p><i>Step 3.</i> Determine the bending moment (M) for the distance (x) from Eq. (2.31b).</p> $M = Fa = (4,500 \text{ N})(0.3 \text{ m})$ $= 1,350 \text{ N} \cdot \text{m}$
<p>Example 3. Calculate and locate the maximum shear force (V_{\max}) and the maximum bending moment (M_{\max}) for the beam of Examples 1 and 2, where</p> $F = 1,000 \text{ lb}$ $L = 5 \text{ ft}, a = 1 \text{ ft}$ <p>solution</p> <p><i>Step 1.</i> Calculate the maximum shear force (V_{\max}) from Eq. (2.30) as</p> $V_{\max} = F = 1,000 \text{ lb}$ <p><i>Step 2.</i> Fig. 2.48 shows that the maximum shear force (V_{\max}) occurs in two regions: one from the left end of the beam to the first concentrated force, and the other from the second concentrated force to the right end of the beam.</p> <p><i>Step 3.</i> Calculate the maximum bending moment (M_{\max}) from Eq. (2.32).</p> $M_{\max} = Fa = (1,000 \text{ lb})(1 \text{ ft})$ $= 1,000 \text{ ft} \cdot \text{lb}$ <p><i>Step 4.</i> From Fig. 2.49 we see that the maximum bending moment (M_{\max}) occurs in the region between the two forces.</p>	<p>Example 3. Calculate and locate the maximum shear force (V_{\max}) and the maximum bending moment (M_{\max}) for the beam of Examples 1 and 2, where</p> $F = 4,500 \text{ N}$ $L = 1.5 \text{ m}, a = 0.3 \text{ m}$ <p>solution</p> <p><i>Step 1.</i> Calculate the maximum shear force (V_{\max}) from Eq. (2.30) as</p> $V_{\max} = F = 4,500 \text{ N}$ <p><i>Step 2.</i> As shown in Fig. 2.48 the maximum shear force (V_{\max}) occurs in two regions, one from the left end of the beam to the first concentrated force, and the other from the second concentrated force to the right end of the beam.</p> <p><i>Step 3.</i> Calculate the maximum bending moment (M_{\max}) from Eq. (2.32).</p> $M_{\max} = Fa = (4,500 \text{ N})(0.3 \text{ m})$ $= 1,350 \text{ N} \cdot \text{m}$ <p><i>Step 4.</i> From Fig. 2.49 we see that the maximum bending moment (M_{\max}) occurs in the region between the two forces.</p>

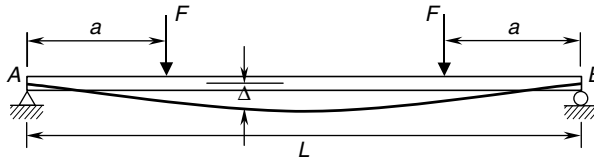

FIGURE 2.50 Beam deflection diagram.

Deflection. For this loading configuration, the deflection (Δ) along the beam is shown in Fig. 2.50, and given by Eq. (2.33a) for the values of the distance (x) from where the first of the twin forces acts, and Eq. (2.33b) between the forces. Symmetry covers the deflection from the second twin force to the right end of the beam.

$$\Delta = \frac{Fx}{6EI} [3La - 3a^2 - x^2] \quad 0 \leq x \leq a \quad (2.33a)$$

$$\Delta = \frac{Fa}{6EI} [3Lx - a^2 - 3x^2] \quad a \leq x \leq L - a \quad (2.33b)$$

- where Δ = deflection of beam with positive downward
- F = concentrated forces equidistant from ends of beam
- x = distance from left end of beam
- L = length of beam
- a = location of forces (F) from ends of beam
- E = modulus of elasticity of beam material
- I = area moment of inertia of cross-sectional area about axis through centroid

The maximum deflection (Δ_{\max}) occurs at the midpoint of the beam and is given by Eq. (2.34)

$$\Delta_{\max} = \frac{Fa}{24EI} (3L^2 - 4a^2) \quad \text{at } x = \frac{L}{2} \quad (2.34)$$

U.S. Customary	SI/Metric
<p>Example 4. Calculate the deflection (Δ) of a simply-supported beam of length (L) with twin concentrated forces, both of magnitude (F) and located equidistant from the supports, at a distance (x), where</p> <p>$F = 1,000 \text{ lb}$ $L = 5 \text{ ft}, a = 1 \text{ ft}$ $x = 2 \text{ ft}$ $E = 10.3 \times 10^6 \text{ lb/in}^2$ (aluminum) $I = 63 \text{ in}^4$</p> <p>solution <i>Step 1.</i> Note that the distance (x) of 2 ft is between the two forces.</p> <p style="text-align: center;">$a \leq x \leq L - a$ or $1 \text{ ft} \leq 2 \text{ ft} \leq 4 \text{ ft}$</p>	<p>Example 4. Calculate the deflection (Δ) of a simply-supported beam of length (L) with twin concentrated forces, both of magnitude (F) and located equidistant from the supports, at a distance (x), where</p> <p>$F = 4,500 \text{ N}$ $L = 1.5 \text{ m}, a = 0.3 \text{ m}$ $x = 0.5 \text{ m}$ $E = 71 \times 10^9 \text{ N/m}^2$ (aluminum) $I = 2,454 \text{ cm}^4$</p> <p>solution <i>Step 1.</i> Note that the distance (x) of 0.5 m is between the two forces.</p> <p style="text-align: center;">$a \leq x \leq L - a$ or $0.3 \text{ m} \leq 0.5 \text{ m} \leq 1.2 \text{ m}$</p>

U.S. Customary	SI/Metric
<p><i>Step 2.</i> Calculate the stiffness (EI).</p> $EI = (10.3 \times 10^6 \text{ lb/in}^2)(63 \text{ in}^4)$ $= \frac{6.49 \times 10^8 \text{ lb} \cdot \text{in}^2 \times 1 \text{ ft}^2}{144 \text{ in}^2}$ $= 4.51 \times 10^6 \text{ lb} \cdot \text{ft}^2$ <p><i>Step 3.</i> Determine the deflection (Δ) from Eq. (2.33b).</p> $\Delta = \frac{Fa}{6EI}[3Lx - a^2 - 3x^2]$ $= \frac{(1,000 \text{ lb})(1 \text{ ft})}{6(4.51 \times 10^6 \text{ lb} \cdot \text{ft}^2)}$ $\times [(3(5)(2) - (1)^2 - 3(2)^2) \text{ ft}^2]$ $= \frac{(1,000 \text{ ft} \cdot \text{lb})}{(2.71 \times 10^7 \text{ lb} \cdot \text{ft}^2)}$ $\times [(30 - 1 - 12) \text{ ft}^2]$ $= \left(3.69 \times 10^{-5} \frac{1}{\text{ft}}\right) \times [17 \text{ ft}^2]$ $= 0.00063 \text{ ft} \times \frac{12 \text{ in}}{\text{ft}}$ $= 0.0075 \text{ in} \downarrow$ <p>Example 5. Calculate and locate the maximum deflection (Δ_{\max}) for the beam configuration of Example 4, where</p> $F = 1,000 \text{ lb}$ $L = 5 \text{ ft}, a = 1 \text{ ft}$ $EI = 4.51 \times 10^6 \text{ lb} \cdot \text{ft}^2$ <p>solution Calculate the maximum deflection (Δ_{\max}) from Eq. (2.34).</p> $\Delta_{\max} = \frac{Fa}{24EI}(3L^2 - 4a^2)$ $= \frac{(1,000 \text{ lb})(1 \text{ ft})}{24(4.51 \times 10^6 \text{ lb} \cdot \text{ft}^2)}$ $\times [(3(5)^2 - 4(1)^2) \text{ ft}^2]$ $= \frac{(1,000 \text{ ft} \cdot \text{lb})}{(1.08 \times 10^8 \text{ lb} \cdot \text{ft}^2)}$ $\times [(75 - 4) \text{ ft}^2]$ $= \left(9.24 \times 10^{-6} \frac{1}{\text{ft}}\right) [71 \text{ ft}^2]$ $= 0.000656 \text{ ft} \times \frac{12 \text{ in}}{\text{ft}}$ $= 0.0079 \text{ in} \downarrow$	<p><i>Step 2.</i> Calculate the stiffness (EI).</p> $EI = (71 \times 10^9 \text{ N/m}^2)(2,454 \text{ cm}^4)$ $\times \frac{1 \text{ m}^4}{(100 \text{ cm})^4}$ $= 1.74 \times 10^6 \text{ N} \cdot \text{m}^2$ <p><i>Step 3.</i> Determine the deflection (Δ) from Eq. (2.33b).</p> $\Delta = \frac{Fa}{6EI}[3Lx - a^2 - 3x^2]$ $= \frac{(4,500 \text{ N})(0.3 \text{ m})}{6(1.74 \times 10^6 \text{ N} \cdot \text{m}^2)}$ $\times [(3(1.5)(0.5) - (0.3)^2 - 3(0.5)^2) \text{ m}^2]$ $= \frac{(1,350 \text{ N} \cdot \text{m})}{(1.04 \times 10^7 \text{ N} \cdot \text{m}^2)}$ $\times [(2.25 - 0.09 - 0.75) \text{ m}^2]$ $= \left(1.30 \times 10^{-4} \frac{1}{\text{m}}\right) \times [1.41 \text{ m}^2]$ $= 0.000182 \text{ m} \times \frac{100 \text{ cm}}{\text{m}}$ $= 0.0182 \text{ cm} \downarrow$ <p>Example 5. Calculate and locate the maximum deflection (Δ_{\max}) for the beam configuration of Example 4, where</p> $F = 4,500 \text{ N}$ $L = 1.5 \text{ m}, a = 0.3 \text{ m}$ $EI = 1.74 \times 10^6 \text{ N} \cdot \text{m}^2$ <p>solution Calculate the maximum deflection (Δ_{\max}) from Eq. (2.34).</p> $\Delta_{\max} = \frac{Fa}{24EI}(3L^2 - 4a^2)$ $= \frac{(4,500 \text{ N})(0.3 \text{ m})}{24(1.74 \times 10^6 \text{ N} \cdot \text{m}^2)}$ $\times [(3(1.5)^2 - 4(0.3)^2) \text{ m}^2]$ $= \frac{(1,350 \text{ N} \cdot \text{m})}{(4.18 \times 10^7 \text{ N} \cdot \text{m}^2)}$ $\times [(6.75 - 0.36) \text{ m}^2]$ $= \left(3.23 \times 10^{-5} \frac{1}{\text{m}}\right) [6.39 \text{ m}^2]$ $= 0.000206 \text{ m} \times \frac{100 \text{ cm}}{\text{m}}$ $= 0.0206 \text{ cm} \downarrow$

2.2.7 Single Overhang: Concentrated Force at Free End

The simply-supported beam in Fig. 2.51 has a single overhang on the right with a concentrated force (F) acting vertically downward at the free end, point C . The distance between the supports is labeled (L), and the length of the overhang is labeled (a), so the total length of the beam is ($L + a$).

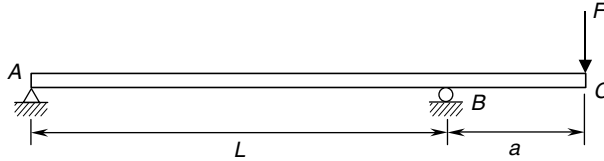

FIGURE 2.51 Single overhang: concentrated force at free end.

Reactions. The reactions at the supports are shown in Fig. 2.52—the balanced free-body diagram. Notice that the vertical reaction (A_y) is downward, whereas the vertical reaction (B_y) is upward, and has a magnitude greater than the concentrated force (F). The force (F) is acting straight down, so the horizontal reaction (A_x) is zero. If the force (F) had a horizontal component, then the horizontal reaction (A_x) would be equal but opposite in direction to this horizontal component.



FIGURE 2.52 Free-body diagram.

U.S. Customary	SI/Metric
<p>Example 1. Determine the reactions for a single overhanging beam of length (L) and overhang (a) with a concentrated force (F) acting at the free end, where</p> $F = 450 \text{ lb}$ $L = 3 \text{ ft}, a = 1 \text{ ft}$ <p>solution</p> <p><i>Step 1.</i> From Fig. 2.52 calculate the pin reactions (A_x and A_y) at the left end of the beam. As the force (F) is vertical,</p> $A_x = 0$ <p>and the vertical reaction (A_y) is</p> $A_y = -\frac{Fa}{L} = \frac{(450 \text{ lb})(1 \text{ ft})}{3 \text{ ft}}$ $= -\frac{450 \text{ ft} \cdot \text{lb}}{3 \text{ ft}} = -150 \text{ lb}$	<p>Example 1. Determine the reactions for a single overhanging beam of length (L) and overhang (a) with a concentrated force (F) acting at the free end, where</p> $F = 2,000 \text{ N}$ $L = 1 \text{ m}, a = 0.3 \text{ m}$ <p>solution</p> <p><i>Step 1.</i> From Fig. 2.52 calculate the pin reactions (A_x and A_y) at the left end of the beam. As the force (F) is vertical,</p> $A_x = 0$ <p>and the vertical reaction (A_y) is</p> $A_y = -\frac{Fa}{L} = \frac{(2,000 \text{ N})(0.3 \text{ m})}{1 \text{ m}}$ $= -\frac{600 \text{ N} \cdot \text{m}}{1 \text{ m}} = -600 \text{ N}$

U.S. Customary	SI/Metric
<p>Step 2. From Fig. 2.52 calculate the roller reaction (B_y) as</p> $B_y = \frac{F(L + a)}{L} = \frac{(450 \text{ lb})(3 \text{ ft} + 1 \text{ ft})}{3 \text{ ft}}$ $= \frac{1,800 \text{ ft} \cdot \text{lb}}{3 \text{ ft}} = 600 \text{ lb}$	<p>Step 2. From Fig. 2.52 calculate the roller reaction (B_y) as</p> $B_y = \frac{F(L + a)}{L} = \frac{(2,000 \text{ N})(1 \text{ m} + 0.3 \text{ m})}{1 \text{ m}}$ $= \frac{2,600 \text{ N} \cdot \text{m}}{1 \text{ m}} = 2,600 \text{ N}$

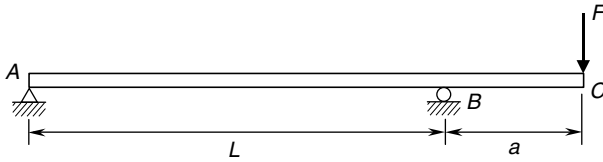

FIGURE 2.53 Single overhang: concentrated force at free end.

Shear Force and Bending Moment Distributions. For a single overhanging beam of length (L) and overhang (a) with a concentrated force (F) acting at the free end, as shown in Fig. 2.53, which has the balanced free-body-diagram as shown in Fig. 2.54, the shear force (V) distribution is shown in Fig. 2.55.



FIGURE 2.54 Free-body-diagram.

Note that the shear force (V) is a negative (Fb/L) from the left end of the beam to the roller support at point B , and a positive (F) from the roller to the free end. So there is a discontinuity in the shear force at the roller of magnitude ($F[L + a]/L$).

The maximum shear force (V_{\max}) occurs in the region of the overhang and is given by Eq. (2.35)

$$V_{\max} = F \tag{2.35}$$

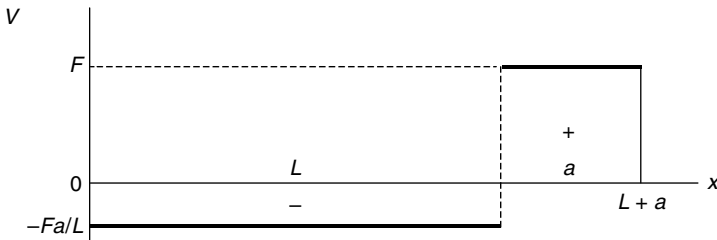

FIGURE 2.55 Shear force diagram.

The bending moment distribution is given by Eq. (2.36a) for the values of the distance (x) from the left end of the beam to the roller, and Eq. (2.36b) from the roller to the free end. (Always measure the distance (x) from the left end of any beam.)

$$M = -\frac{Fa}{L}x \quad 0 \leq x \leq L \quad (2.36a)$$

$$M = -F(L + a - x) \quad L \leq x \leq L + a \quad (2.36b)$$

The bending moment (M) distribution is shown in Fig. 2.56.

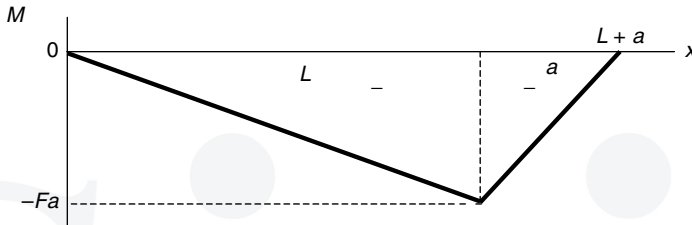

FIGURE 2.56 Bending moment diagram.

Note that the bending moment (M) is zero at the left end, decreases linearly to a maximum negative value at the roller, and then increases linearly back to zero. The maximum bending moment (M_{\max}), the absolute value of this negative quantity, occurs at the roller and is given by Eq. (2.37).

$$M_{\max} = Fa \quad (2.37)$$

U.S. Customary	SI/Metric
<p>Example 2. Calculate the shear force (V) and bending moment (M) for a single overhanging beam of length (L) and overhang (a) with a concentrated force (F) acting at the free end, at a distance (x), where</p> <p>$F = 450 \text{ lb}$ $L = 3 \text{ ft}, a = 1 \text{ ft}$ $x = 2 \text{ ft}$</p> <p>solution <i>Step 1.</i> Determine the shear force (V) from Fig. (2.55) as</p> $V = -\frac{Fa}{L} = -\frac{(450 \text{ lb})(1 \text{ ft})}{3 \text{ ft}}$ $= -\frac{450 \text{ ft} \cdot \text{lb}}{3 \text{ ft}} = -150 \text{ lb}$	<p>Example 2. Calculate the shear force (V) and bending moment (M) for a single overhanging beam of length (L) and overhang (a) with a concentrated force (F) acting at the free end, at a distance (x), where</p> <p>$F = 2,000 \text{ N}$ $L = 1 \text{ m}, a = 0.3 \text{ m}$ $x = 0.6 \text{ m}$</p> <p>solution <i>Step 1.</i> Determine the shear force (V) from Fig. 2.55 as</p> $V = -\frac{Fa}{L} = \frac{(2,000 \text{ N})(0.3 \text{ m})}{1 \text{ m}}$ $= -\frac{600 \text{ N} \cdot \text{m}}{1 \text{ m}} = -600 \text{ N}$

U.S. Customary	SI/Metric
<p><i>Step 2.</i> As the distance (x) is less than the length (L), the bending moment (M) is determined from Eq. (2.36a).</p> $M = -\frac{Fa}{L}x = -\frac{(450 \text{ lb})(1 \text{ ft})}{3 \text{ ft}}(2 \text{ ft})$ $= -\frac{450 \text{ ft} \cdot \text{lb}}{3 \text{ ft}}(2 \text{ ft})$ $= -(150 \text{ lb})(2 \text{ ft}) = -300 \text{ ft} \cdot \text{lb}$ <p>Example 3. Calculate and locate the maximum shear force (V_{\max}) and the maximum bending moment (M_{\max}) for the beam of Example 2, where</p> $F = 450 \text{ lb}$ $L = 3 \text{ ft}, a = 1 \text{ ft}$ <p>solution</p> <p><i>Step 1.</i> Calculate the maximum shear force (V_{\max}) from Eq. (2.35) as</p> $V_{\max} = F = 450 \text{ lb}$ <p><i>Step 2.</i> From Fig. 2.55 this maximum shear force (V_{\max}) of 450 lb occurs in the region of the overhang.</p> <p><i>Step 3.</i> Calculate the maximum bending moment (M_{\max}) from Eq. (2.37) as</p> $M_{\max} = Fa = (450 \text{ lb})(1 \text{ ft})$ $= 450 \text{ ft} \cdot \text{lb}$ <p><i>Step 4.</i> Figure 2.56 shows that this maximum bending moment (M_{\max}) of 450 ft · lb occurs at the roller.</p>	<p><i>Step 2.</i> As the distance (x) is less than the length (L), the bending moment (M) is determined from Eq. (2.36a).</p> $M = -\frac{Fa}{L}x = -\frac{(2,000 \text{ N})(0.3 \text{ m})}{1 \text{ m}}(0.6 \text{ m})$ $= -\frac{600 \text{ N} \cdot \text{m}}{1 \text{ m}}(0.6 \text{ m})$ $= -(600 \text{ N})(0.6 \text{ m}) = -360 \text{ N} \cdot \text{m}$ <p>Example 3. Calculate and locate the maximum shear force (V_{\max}) and the maximum bending moment (M_{\max}) for the beam of Example 2, where</p> $F = 2,000 \text{ N}$ $L = 1 \text{ m}, a = 0.3 \text{ m}$ <p>solution</p> <p><i>Step 1.</i> Calculate the maximum shear force (V_{\max}) from Eq. (2.35) as</p> $V_{\max} = F = 2,000 \text{ N}$ <p><i>Step 2.</i> Figure 2.55 shows that this maximum shear force (V_{\max}) of 2,000 N occurs in the region of the overhang.</p> <p><i>Step 3.</i> Calculate the maximum bending moment (M_{\max}) from Eq. (2.37) as</p> $M_{\max} = Fa = (2,000 \text{ N})(0.3 \text{ m})$ $= 600 \text{ N} \cdot \text{m}$ <p><i>Step 4.</i> Figure 2.56 shows that this maximum bending moment (M_{\max}) of 600 N · m occurs at the roller.</p>

Deflection. For this loading configuration, the deflection (Δ) along the beam is shown in Fig. 2.57, and given by Eq. (2.38a) for the values of the distance (x) from the left end of the beam to the roller at point B , and given by Eq. (2.38b) for values of the distance (x) from the roller to the free end where the force (F) acts.

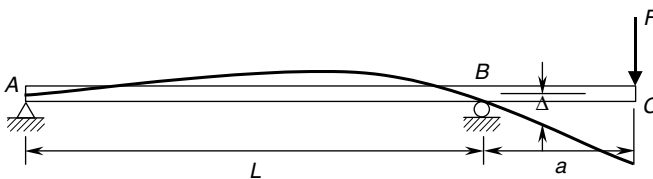

FIGURE 2.57 Beam deflection diagram.

$$\Delta = \frac{Fax}{6EI}(L^2 - x^2) \uparrow \quad 0 \leq x \leq L \quad (2.38a)$$

$$\Delta = \frac{F(x-L)}{6EI}[a(3x-L) - (x-L)^2] \downarrow \quad L \leq x \leq L+a \quad (2.38b)$$

where Δ = deflection of the beam

F = applied force at free end

x = distance from left end of beam

L = length between supports

a = length of overhang

E = modulus of elasticity of beam material

I = area moment of inertia of cross-sectional area about axis through centroid

Note that the deflection (Δ) is upward between the supports and downward for the overhang. The distance (x) in Eq. (2.38a) must be between 0 and (L), and the distance (x) in Eq. (2.38b) must be between (L) and the total length of the beam ($L+a$).

There is a maximum upward deflection between the supports, given by Eq. (2.39),

$$\Delta_{\max} = \frac{FaL^2}{9\sqrt{3}EI} \uparrow \quad \text{at } x = \frac{L}{\sqrt{3}} \quad (2.39)$$

and a maximum downward deflection at the free end, where the force (F) acts, as given by Eq. (2.40),

$$\Delta_{\max} = \frac{Fa^2}{3EI}(L+a) \downarrow \quad \text{at } x = L+a \quad (2.40)$$

Note that the maximum upward deflection does not occur at the midpoint ($L/2$) between the supports, but at a point closer to the roller at point B . The magnitude of the deflection at the free end is usually greater than the magnitude of the deflection between the supports.

U.S. Customary	SI/Metric
<p>Example 4. Calculate the deflection (Δ) of a single overhanging beam of length (L) and overhang (a) with a concentrated force (F) acting at the free end, at a distance (x), where</p> <p>$F = 450 \text{ lb}$ $L = 3 \text{ ft}, a = 1 \text{ ft}$ $x = 2 \text{ ft}$ $E = 30 \times 10^6 \text{ lb/in}^2$ (steel) $I = 12 \text{ in}^4$</p> <p>solution <i>Step 1.</i> Calculate the stiffness (EI).</p> $\begin{aligned} EI &= (30 \times 10^6 \text{ lb/in}^2)(12 \text{ in}^4) \\ &= \frac{3.6 \times 10^8 \text{ lb} \cdot \text{in}^2 \times 1 \text{ ft}^2}{144 \text{ in}^2} \\ &= 2.5 \times 10^6 \text{ lb} \cdot \text{ft}^2 \end{aligned}$	<p>Example 4. Calculate the deflection (Δ) of a single overhanging beam of length (L) and overhang (a) with a concentrated force (F) acting at the free end, at a distance (x), where</p> <p>$F = 2,000 \text{ N}$ $L = 1 \text{ m}, a = 0.3 \text{ m}$ $x = 0.6 \text{ m}$ $E = 207 \times 10^9 \text{ N/m}^2$ (steel) $I = 491 \text{ cm}^4$</p> <p>solution <i>Step 1.</i> Calculate the stiffness (EI).</p> $\begin{aligned} EI &= (207 \times 10^9 \text{ N/m}^2)(491 \text{ cm}^4) \\ &= \frac{1 \text{ m}^4}{(100 \text{ cm})^4} \\ &= 1.02 \times 10^6 \text{ N} \cdot \text{m}^2 \end{aligned}$

U.S. Customary	SI/Metric
<p><i>Step 2.</i> As the distance (x) is less than the length (L), the deflection (Δ) is determined from Eq. (2.38a).</p> $\begin{aligned}\Delta &= \frac{Fax}{6EIL}(L^2 - x^2) \uparrow \\ &= \frac{(450 \text{ lb})(1 \text{ ft})(2 \text{ ft})}{6(2.5 \times 10^6 \text{ lb} \cdot \text{ft}^2)(3 \text{ ft})} \\ &\quad \times [(3 \text{ ft})^2 - (2 \text{ ft})^2] \\ &= \frac{(900 \text{ lb} \cdot \text{ft}^2)}{(4.5 \times 10^7 \text{ lb} \cdot \text{ft}^3)} \\ &\quad \times [(9 \text{ ft}^2) - (4 \text{ ft}^2)] \\ &= \left(2.0 \times 10^{-5} \frac{1}{\text{ft}}\right) \times [5 \text{ ft}^2] \\ &= 0.0001 \text{ ft} \times \frac{12 \text{ in}}{\text{ft}} \\ &= 0.0012 \text{ in} \uparrow\end{aligned}$ <p>Example 5. Calculate the maximum downward deflection (Δ_{\max}) for the beam configuration in Example 4, where</p> $\begin{aligned}F &= 450 \text{ lb} \\ L &= 3 \text{ ft}, a = 1 \text{ ft} \\ EI &= 2.5 \times 10^6 \text{ lb} \cdot \text{ft}^2\end{aligned}$ <p>solution The maximum downward deflection occurs at the free end where the force (F) acts, and is determined from Eq. (2.40).</p> $\begin{aligned}\Delta_{\max} &= \frac{Fa^2}{3EI}(L + a) \\ &= \frac{(450 \text{ lb})(1 \text{ ft})^2}{3(2.5 \times 10^6 \text{ lb} \cdot \text{ft}^2)}(3 \text{ ft} + 1 \text{ ft}) \\ &= \frac{450 \text{ lb} \cdot \text{ft}^2}{7.5 \times 10^6 \text{ lb} \cdot \text{ft}^2}(4 \text{ ft}) \\ &= (6.0 \times 10^{-5})(4 \text{ ft}) \\ &= 0.00024 \text{ ft} \times \frac{12 \text{ in}}{\text{ft}} \\ &= 0.0029 \text{ in} \downarrow\end{aligned}$ <p>Example 6. Calculate and locate the maximum upward deflection (Δ_{\max}) for the beam configuration of Example 4, where</p> $\begin{aligned}F &= 450 \text{ lb} \\ L &= 3 \text{ ft}, a = 1 \text{ ft} \\ EI &= 2.5 \times 10^6 \text{ lb} \cdot \text{ft}^2\end{aligned}$	<p><i>Step 2.</i> As the distance (x) is less than the length (L), the deflection (Δ) is determined from Eq. (2.38a).</p> $\begin{aligned}\Delta &= \frac{Fax}{6EIL}(L^2 - x^2) \uparrow \\ &= \frac{(2,000 \text{ N})(0.3 \text{ m})(0.6 \text{ m})}{6(1.02 \times 10^6 \text{ N} \cdot \text{m}^2)(1 \text{ m})} \\ &\quad \times [(1 \text{ m})^2 - (0.6 \text{ m})^2] \\ &= \frac{(360 \text{ N} \cdot \text{m}^2)}{(6.12 \times 10^6 \text{ N} \cdot \text{m}^3)} \\ &\quad \times [(1 \text{ m}^2) - (0.36 \text{ m}^2)] \\ &= \left(5.88 \times 10^{-5} \frac{1}{\text{m}}\right) \times [0.64 \text{ m}^2] \\ &= 0.000038 \text{ m} \times \frac{100 \text{ cm}}{\text{m}} \\ &= 0.0038 \text{ cm} \uparrow\end{aligned}$ <p>Example 5. Calculate the maximum downward deflection (Δ_{\max}) for the beam configuration in Example 4, where</p> $\begin{aligned}F &= 2,000 \text{ N} \\ L &= 1 \text{ m}, a = 0.3 \text{ m} \\ EI &= 1.02 \times 10^6 \text{ N} \cdot \text{m}^2\end{aligned}$ <p>solution The maximum downward deflection occurs at the free end where the force (F) acts, and is determined from Eq. (2.40).</p> $\begin{aligned}\Delta_{\max} &= \frac{Fa^2}{3EI}(L + a) \\ &= \frac{(2,000 \text{ N})(0.3 \text{ m})^2}{3(1.02 \times 10^6 \text{ N} \cdot \text{m}^2)}(1 \text{ m} + 0.3 \text{ m}) \\ &= \frac{180 \text{ N} \cdot \text{m}^2}{3.06 \times 10^6 \text{ N} \cdot \text{m}^2}(1.3 \text{ m}) \\ &= (5.88 \times 10^{-5})(1.3 \text{ m}) \\ &= 0.000076 \text{ m} \times \frac{100 \text{ cm}}{\text{m}} \\ &= 0.0076 \text{ cm} \downarrow\end{aligned}$ <p>Example 6. Calculate and locate the maximum upward deflection (Δ_{\max}) for the beam configuration of Example 4, where</p> $\begin{aligned}F &= 2,000 \text{ N} \\ L &= 1 \text{ m}, a = 0.3 \text{ m} \\ EI &= 1.02 \times 10^6 \text{ N} \cdot \text{m}^2\end{aligned}$

U.S. Customary	SI/Metric
<p>solution</p> <p><i>Step 1.</i> Calculate the maximum upward deflection (Δ_{\max}) from Eq. (2.39).</p> $\begin{aligned}\Delta_{\max} &= \frac{FaL^2}{9\sqrt{3}EI} \\ &= \frac{(450\text{ lb})(1\text{ ft})(3\text{ ft})^2}{9\sqrt{3}(2.5 \times 10^6\text{ lb}\cdot\text{ft}^2)} \\ &= \frac{4,050\text{ lb}\cdot\text{ft}^3}{3.9 \times 10^7\text{ lb}\cdot\text{ft}^2} \\ &= 0.0001\text{ ft} \times \frac{12\text{ in}}{\text{ft}} \\ &= 0.0012\text{ in} \uparrow\end{aligned}$ <p><i>Step 2.</i> From Eq. (2.39) the location of the maximum upward deflection is</p> $\begin{aligned}x_{\Delta_{\max}} &= \frac{L}{\sqrt{3}} = \frac{3\text{ ft}}{\sqrt{3}} \\ &= 1.73\text{ ft} \\ &> \frac{L}{2} = \frac{3\text{ ft}}{2} = 1.5\text{ ft}\end{aligned}$	<p>solution</p> <p><i>Step 1.</i> Calculate the maximum upward deflection (Δ_{\max}) from Eq. (2.39).</p> $\begin{aligned}\Delta_{\max} &= \frac{FaL^2}{9\sqrt{3}EI} \\ &= \frac{(2,000\text{ N})(0.3\text{ m})(1\text{ m})^2}{9\sqrt{3}(1.02 \times 10^6\text{ N}\cdot\text{m}^2)} \\ &= \frac{600\text{ N}\cdot\text{m}^3}{1.59 \times 10^7\text{ N}\cdot\text{m}^2} \\ &= 0.000038\text{ m} \times \frac{100\text{ cm}}{\text{m}} \\ &= 0.0038\text{ cm} \uparrow\end{aligned}$ <p><i>Step 2.</i> From Eq. (2.39) the location of the maximum upward deflection is</p> $\begin{aligned}x_{\Delta_{\max}} &= \frac{L}{\sqrt{3}} = \frac{1\text{ m}}{\sqrt{3}} \\ &= 0.577\text{ m} \\ &> \frac{L}{2} = \frac{1\text{ m}}{2} = 0.5\text{ m}\end{aligned}$

2.2.8 Single Overhang: Uniform Load

The simply-supported beam in Fig. 2.58 has a single overhang at the right with a uniform distributed load (w) acting vertically downward across the entire length of the beam. The distance between the supports is labeled (L), and the length of the overhang is labeled (a), so the total length of the beam is ($L + a$).

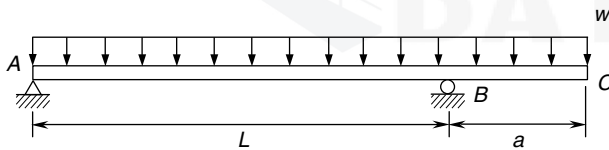

FIGURE 2.58 Single overhang: uniform load.

Reactions. The reactions at the supports are shown in Fig. 2.59—the balanced free-body diagram. Notice that the total load on the beam, ($w[L + a]$), is not split evenly between the

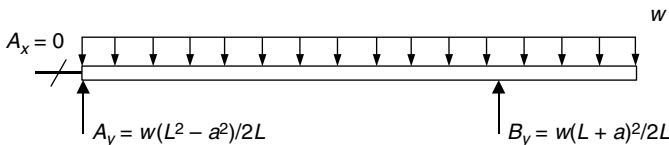

FIGURE 2.59 Free-body diagram.

two vertical reactions (A_y and B_y). As the distributed load is acting directly downward, the horizontal reaction (A_x) is zero.

To provide a comparison between uniform loading on this beam and concentrated force loading at the free end of the previous beam, the magnitude of the uniform load (w) has been chosen to produce a total force equal to the concentrated force (F). Also, the beam dimensions, material properties, and cross-sectional properties of this beam are the same as the previous beam.

U.S. Customary	SI/Metric
<p>Example 1. Determine the reactions for a single overhanging beam of length (L) and overhang (a) with a uniformly distributed load (w), where</p> $w = 113 \text{ lb/ft}$ $L = 3 \text{ ft}, a = 1 \text{ ft}$ <p>solution</p> <p><i>Step 1.</i> From Fig. 2.59 calculate the pin reactions (A_x and A_y) at the left end of the beam. As the uniform load (w) is vertical,</p> $A_x = 0$ <p>and the vertical reaction (A_y) is</p> $A_y = \frac{w(L^2 - a^2)}{2L}$ $= \frac{(113 \text{ lb/ft})[(3 \text{ ft})^2 - (1 \text{ ft})^2]}{2(3 \text{ ft})}$ $= \frac{(113 \text{ lb/ft})[9 \text{ ft}^2 - 1 \text{ ft}^2]}{(6 \text{ ft})}$ $= \frac{(113 \text{ lb/ft})[8 \text{ ft}^2]}{(6 \text{ ft})}$ $= \frac{904 \text{ ft} \cdot \text{lb}}{6 \text{ ft}} = 151 \text{ lb}$ <p><i>Step 2.</i> From Fig. 2.59 calculate the roller reaction (B_y) as</p> $B_y = \frac{w(L^2 + a^2)}{2L}$ $= \frac{(113 \text{ lb/ft})(3 \text{ ft} + 1 \text{ ft})^2}{2(3 \text{ ft})}$ $= \frac{(113 \text{ lb/ft})(4 \text{ ft})^2}{(6 \text{ ft})}$ $= \frac{(113 \text{ lb/ft})(16 \text{ ft}^2)}{(6 \text{ ft})}$ $= \frac{1,808 \text{ ft} \cdot \text{lb}}{6 \text{ ft}} = 301 \text{ lb}$	<p>Example 1. Determine the reactions for a single overhanging beam of length (L) and overhang (a) with a uniformly distributed load (w), where</p> $w = 1,540 \text{ N/m}$ $L = 1 \text{ m}, a = 0.3 \text{ m}$ <p>solution</p> <p><i>Step 1.</i> From Fig. 2.59 calculate the pin reactions (A_x and A_y) at the left end of the beam. As the uniform load (w) is vertical,</p> $A_x = 0$ <p>and the vertical reaction (A_y) is</p> $A_y = \frac{w(L^2 - a^2)}{2L}$ $= \frac{(1,540 \text{ N/m})[(1 \text{ m})^2 - (0.3 \text{ m})^2]}{2(1 \text{ m})}$ $= \frac{(1,540 \text{ N/m})[1 \text{ m}^2 - 0.09 \text{ m}^2]}{(2 \text{ m})}$ $= \frac{(1,540 \text{ N/m})[0.91 \text{ m}^2]}{(2 \text{ m})}$ $= \frac{1,402 \text{ N} \cdot \text{m}}{2 \text{ m}} = 701 \text{ N}$ <p><i>Step 2.</i> From Fig. 2.59 calculate the roller reaction (B_y) as</p> $B_y = \frac{w(L^2 + a^2)}{2L}$ $= \frac{(1,540 \text{ N/m})(1 \text{ m} + 0.3 \text{ m})^2}{2(1 \text{ m})}$ $= \frac{(1,540 \text{ N/m})(1.3 \text{ m})^2}{(2 \text{ m})}$ $= \frac{(1,540 \text{ N/m})(1.69 \text{ m}^2)}{(2 \text{ m})}$ $= \frac{2,602 \text{ N} \cdot \text{m}}{2 \text{ m}} = 1,301 \text{ N}$

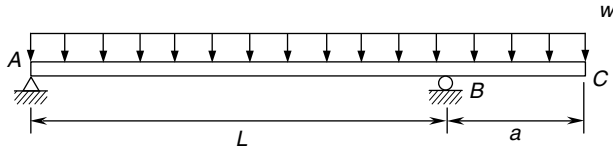

FIGURE 2.60 Concentrated force at intermediate point.

Shear Force and Bending Moment Distributions. For the single overhanging beam of length (L) and overhang (a) with a uniform load (w), shown in Fig. 2.60, which has the balanced free-body-diagram shown in Fig. 2.61, the shear force (V) distribution is shown in Fig. 2.62.

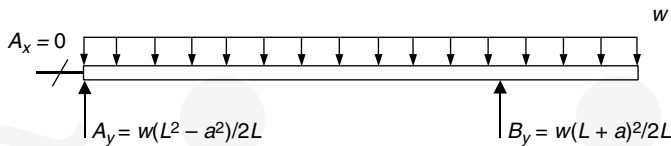

FIGURE 2.61 Free-body-diagram.

The shear force (V) from the left pin support to the roller support is found from Eq. (2.41a), and from the roller support to the free end is found from Eq. (2.41b).

$$V = \frac{w}{2L}(L^2 - a^2) - wx \quad 0 \leq x \leq L \quad (2.41a)$$

$$V = w(L + a - x) \quad L \leq x \leq L + a \quad (2.41b)$$

Both of these equations represent the same decreasing slope, that is, the value of the uniform load (w). The shear force (V) is zero at the point between the supports shown that is given by Eq. (2.42). This point is always less than half the distance between the supports.

$$x_{V=0} = \frac{L}{2} \left(1 - \frac{a^2}{L^2} \right) \quad (2.42)$$

The maximum shear force (V_{\max}) occurs at the roller and is given by Eq. (2.43).

$$V_{\max} = \frac{w}{2L}(L^2 + a^2) \quad \text{at } x = L \quad (2.43)$$

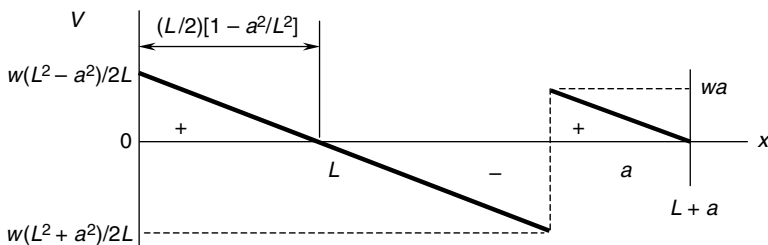

FIGURE 2.62 Shear force diagram.

The bending moment distribution is given by Eq. (2.44a) for the values of the distance (x) from the left end of the beam to the roller, and Eq. (2.44b) from the roller to the free end. (Always measure the distance (x) from the left end of any beam.)

$$M = \frac{wx}{2L}(L^2 - a^2 - Lx) \quad 0 \leq x \leq L \quad (2.44a)$$

$$M = \frac{w}{2}(L + a - x)^2 \quad L \leq x \leq L + a \quad (2.44b)$$

The bending moment (M) distribution is shown in Fig. 2.63.

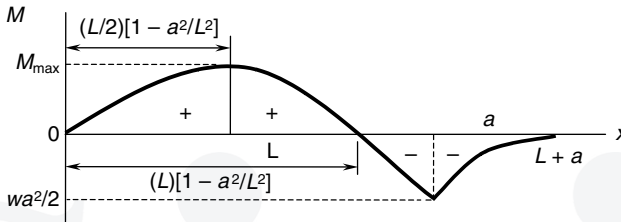

FIGURE 2.63 Bending moment diagram.

The bending moment (M) curves described by Eqs. (2.44a) and (2.44b) are both parabolic, starting at a value of zero at the left pin support, increasing to a maximum positive value, then decreasing to a maximum negative value at the roller support. The maximum bending moment (M_{\max}) is given by Eq. (2.45),

$$M_{\max} = \frac{w}{8L^2}(L + a)^2(L - a)^2 \quad (2.45)$$

located at a position given by Eq. (2.46).

$$x_{M_{\max}} = \frac{L}{2} \left(1 - \frac{a^2}{L^2} \right) \quad (2.46)$$

Note that the location of the maximum bending moment (M_{\max}) is also the same location where the shear force (V) was zero between the supports. This is because the slope of the bending moment diagram (M) is directly related to the shear force (V), so if the shear force is zero, the slope of the bending moment at that point is zero, meaning this is a location of either a maximum or a minimum value in the bending moment.

U.S. Customary	SI/Metric
<p>Example 2. Calculate the shear force (V) and the bending moment (M) for a single overhanging beam of length (L) and overhang (a) with a uniformly distributed load (w), at a distance (x), where</p> <p>$w = 113 \text{ lb/ft}$ $L = 3 \text{ ft}, a = 1 \text{ ft}$ $x = 2 \text{ ft}$</p>	<p>Example 2. Calculate the shear force (V) and bending moment (M) for a single overhanging beam of length (L) and overhang (a) with a uniformly distributed load (w), at a distance (x), where</p> <p>$w = 1,540 \text{ N/m}$ $L = 1 \text{ m}, a = 0.3 \text{ m}$ $x = 0.6 \text{ m}$</p>

U.S. Customary	SI/Metric
<p>solution</p> <p><i>Step 1.</i> As the distance (x) is less than the length (L), the shear force (V) is determined from Eq. (2.41a) as</p> $ \begin{aligned} V &= \frac{w}{2L}(L^2 - a^2) - wx \\ &= \frac{(113 \text{ lb/ft})}{2(3 \text{ ft})}[(3 \text{ ft})^2 - (1 \text{ ft})^2] \\ &\quad - (113 \text{ lb/ft})(2 \text{ ft}) \\ &= \frac{(113 \text{ lb/ft})}{(6 \text{ ft})}[9 \text{ ft}^2 - 1 \text{ ft}^2] \\ &\quad - (226 \text{ lb}) \\ &= (18.83 \text{ lb/ft}^2)[8 \text{ ft}^2] \\ &\quad - (226 \text{ lb}) \\ &= (151 \text{ lb}) - (226 \text{ lb}) \\ &= -75 \text{ lb} \end{aligned} $ <p><i>Step 2.</i> As the distance (x) is less than the length (L), the bending moment (M) is determined from Eq. (2.44a) as</p> $ \begin{aligned} M &= \frac{wx}{2L}(L^2 - a^2 - Lx) \\ &= \frac{(113 \text{ lb/ft})(2 \text{ ft})}{2(3 \text{ ft})} \\ &\quad \times [(3 \text{ ft})^2 - (1 \text{ ft})^2 - (3 \text{ ft})(1 \text{ ft})] \\ &= \frac{(226 \text{ lb})}{(6 \text{ ft})}[9 \text{ ft}^2 - 1 \text{ ft}^2 - 3 \text{ ft}^2] \\ &= (37.67 \text{ lb/ft})[5 \text{ ft}^2] \\ &= 188 \text{ ft} \cdot \text{lb} \end{aligned} $	<p>solution</p> <p><i>Step 1.</i> As the distance (x) is less than the length (L), the shear force (V) is determined from Eq. (2.41a) as</p> $ \begin{aligned} V &= \frac{w}{2L}(L^2 - a^2) - wx \\ &= \frac{(1,540 \text{ N/m})}{2(1 \text{ m})}[(1 \text{ m})^2 - (0.3 \text{ m})^2] \\ &\quad - (1,540 \text{ N/m})(0.6 \text{ m}) \\ &= \frac{(1,540 \text{ N/m})}{(2 \text{ m})}[1 \text{ m}^2 - 0.09 \text{ m}^2] \\ &\quad - (924 \text{ N}) \\ &= (770 \text{ N/m}^2)[0.91 \text{ m}^2] \\ &\quad - (924 \text{ N}) \\ &= (701 \text{ N}) - (924 \text{ N}) \\ &= -223 \text{ N} \end{aligned} $ <p><i>Step 2.</i> As the distance (x) is less than the length (L), the bending moment (M) is determined from Eq. (2.44a) as</p> $ \begin{aligned} M &= \frac{wx}{2L}(L^2 - a^2 - Lx) \\ &= \frac{(1,540 \text{ N/m})(0.6 \text{ m})}{2(1 \text{ m})} \\ &\quad \times [(1 \text{ m})^2 - (0.3 \text{ m})^2 - (1 \text{ m})(0.3 \text{ m})] \\ &= \frac{(924 \text{ N})}{(2 \text{ m})}[1 \text{ m}^2 - 0.09 \text{ m}^2 - 0.3 \text{ m}^2] \\ &= (462 \text{ N/m})[0.61 \text{ m}^2] \\ &= 282 \text{ N} \cdot \text{m} \end{aligned} $
<p>Example 3. Calculate and locate the maximum shear force (V_{\max}) and the maximum bending moment (M_{\max}) for the beam of Example 2, where</p> $ \begin{aligned} w &= 113 \text{ lb/ft} \\ L &= 3 \text{ ft}, a = 1 \text{ ft} \end{aligned} $	<p>Example 3. Calculate and locate the maximum shear force (V_{\max}) and the maximum bending moment (M_{\max}) for the beam of Example 2, where</p> $ \begin{aligned} w &= 1,540 \text{ N/m} \\ L &= 1 \text{ m}, a = 0.3 \text{ m} \end{aligned} $
<p>solution</p> <p><i>Step 1.</i> Calculate the maximum shear force (V_{\max}) from Eq. (2.43) as</p> $ \begin{aligned} V_{\max} &= \frac{w}{2L}(L^2 + a^2) \\ V_{\max} &= \frac{(113 \text{ lb/ft})}{2(3 \text{ ft})}[(3 \text{ ft})^2 + (1 \text{ ft})^2] \\ &= \frac{(113 \text{ lb/ft})}{(6 \text{ ft})}[9 \text{ ft}^2 + 1 \text{ ft}^2] \\ &= \left(\frac{18.83 \text{ lb}}{\text{ft}^2}\right)[10 \text{ ft}^2] = 188 \text{ lb} \end{aligned} $	<p>solution</p> <p><i>Step 1.</i> Calculate the maximum shear force (V_{\max}) from Eq. (2.43) as</p> $ \begin{aligned} V_{\max} &= \frac{w}{2L}(L^2 + a^2) \\ V_{\max} &= \frac{(1,540 \text{ N/m})}{2(1 \text{ m})}[(1 \text{ m})^2 + (0.3 \text{ m})^2] \\ &= \frac{(1,540 \text{ N/m})}{(2 \text{ m})}[1 \text{ m}^2 + 0.09 \text{ m}^2] \\ &= \left(\frac{770 \text{ N}}{\text{m}^2}\right)[1.09 \text{ m}^2] = 839 \text{ N} \end{aligned} $

U.S. Customary	SI/Metric
<p><i>Step 2.</i> From Fig. 2.62, this maximum shear force (V_{\max}) occurs at the roller support.</p> <p><i>Step 3.</i> Calculate the maximum bending moment (M_{\max}) from Eq. (2.45) as</p> $M_{\max} = \frac{w}{8L^2} (L+a)^2(L-a)^2$ $= \frac{(113 \text{ lb/ft})}{8(3 \text{ ft})^2} \times (3 \text{ ft} + 1 \text{ ft})^2(3 \text{ ft} - 1 \text{ ft})^2$ $= \frac{(113 \text{ lb/ft})}{(72 \text{ ft}^2)} \times (4 \text{ ft})^2(2 \text{ ft})^2$ $= \left(\frac{1.57 \text{ lb}}{\text{ft}^3}\right) (16 \text{ ft}^2)(4 \text{ ft}^2)$ $= 100 \text{ ft} \cdot \text{lb}$ <p><i>Step 4.</i> The maximum bending moment (M_{\max}) occurs at the location shown in Fig. 2.63 and given by Eq. (2.46).</p> $x_{M_{\max}} = \frac{L}{2} \left(1 - \frac{a^2}{L^2}\right)$ $= \frac{3 \text{ ft}}{2} \left(1 - \frac{(1 \text{ ft})^2}{(3 \text{ ft})^2}\right)$ $= (1.5 \text{ ft}) \left(1 - \frac{1 \text{ ft}^2}{9 \text{ ft}^2}\right) = (1.5 \text{ ft}) \left(\frac{8}{9}\right)$ $= 1.33 \text{ ft}$	<p><i>Step 2.</i> Figure 2.62 shows that this maximum shear force (V_{\max}) occurs at the roller support.</p> <p><i>Step 3.</i> Calculate the maximum bending moment (M_{\max}) from Eq. (2.45) as</p> $M_{\max} = \frac{w}{8L^2} (L+a)^2(L-a)^2$ $= \frac{(1,540 \text{ N/m})}{8(1 \text{ m})^2} \times (1 \text{ m} + 0.3 \text{ m})^2(1 \text{ m} - 0.3 \text{ m})^2$ $= \frac{(1,540 \text{ N/m})}{(8 \text{ m}^2)} \times (1.3 \text{ m})^2(0.7 \text{ m})^2$ $= \left(\frac{192.5 \text{ N}}{\text{m}^3}\right) (1.69 \text{ m}^2)(0.49 \text{ m}^2)$ $= 159 \text{ N} \cdot \text{m}$ <p><i>Step 4.</i> This maximum bending moment (M_{\max}) occurs at the location shown in Fig. 2.63 and given by Eq. (2.46).</p> $x_{M_{\max}} = \frac{L}{2} \left(1 - \frac{a^2}{L^2}\right)$ $= \frac{1 \text{ m}}{2} \left(1 - \frac{(0.3 \text{ m})^2}{(1 \text{ m})^2}\right)$ $= (0.5 \text{ m}) \left(1 - \frac{0.09 \text{ m}^2}{1 \text{ m}^2}\right)$ $= (0.5 \text{ m})(0.91) = 0.455 \text{ m}$

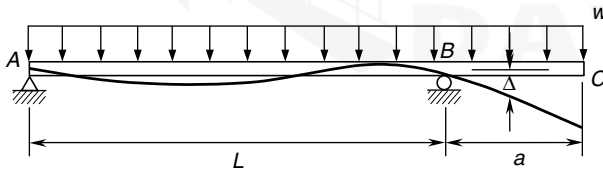

FIGURE 2.64 Beam deflection diagram.

Deflection. For this loading configuration, the deflection (Δ) along the beam is shown in Fig. 2.64, and given by Eq. (2.47a) for values of the distance (x) from the left end of the beam to the roller at point B , and given by Eq. (2.47b) for values of the distance (x) from the roller to the free end.

$$\Delta = \frac{wx}{24EIL} (L^4 - 2L^2x^2 + Lx^3 - 2a^2L^2 + 2a^2x^2) \uparrow \quad 0 \leq x \leq L \quad (2.47a)$$

$$\Delta = \frac{wx_1}{24EI} (4a^2L - L^3 + 6a^2x_1 - 4ax_1^2 + x_1^3) \uparrow \quad L \leq x \leq L + a \quad (2.47b)$$

where Δ = deflection of beam
 w = uniform distributed load

- x = distance from left end of beam
- L = length between supports
- $x_1 = (x - L)$ = distance past roller support on overhang
- a = length of overhang
- E = modulus of elasticity of beam material
- I = area moment of inertia of cross-sectional area about axis through centroid

Note that the distance (x) in Eq. (2.47a) must be between 0 and (L), and the distance (x) in Eq. (2.47b) must be between the distance (L) and the total length of the beam ($L + a$).

U.S. Customary	SI/Metric
<p>Example 4. Calculate the deflection (Δ) of a single overhanging beam of length (L) and overhang (a) with a uniformly distributed load (w), at a distance (x), where</p> <p>$w = 113 \text{ lb/ft}$ $L = 3 \text{ ft}, a = 1 \text{ ft}$ $x = 2 \text{ ft}$ $E = 30 \times 10^6 \text{ lb/in}^2 \text{ (steel)}$ $I = 12 \text{ in}^4$</p> <p>solution</p> <p><i>Step 1.</i> Calculate the stiffness (EI)</p> $EI = (30 \times 10^6 \text{ lb/in}^2) (12 \text{ in}^4)$ $= 3.6 \times 10^8 \text{ lb} \cdot \text{in}^2 \times \frac{1 \text{ ft}^2}{144 \text{ in}^2}$ $= 2.5 \times 10^6 \text{ lb} \cdot \text{ft}^2$ <p><i>Step 2.</i> As the distance (x) is less than the length (L), the deflection (Δ) is determined from Eq. (2.47a).</p> $\Delta = \frac{wx}{24 EIL} (L^4 - 2L^2 x^2 + Lx^3 - 2a^2 L^2 + 2a^2 x^2) \uparrow$ $\Delta = \frac{(113 \text{ lb/ft}) (2 \text{ ft})}{24 (2.5 \times 10^6 \text{ lb} \cdot \text{ft}^2) (3 \text{ ft})} \times [(3 \text{ ft})^4 - 2 (3 \text{ ft})^2 (2 \text{ ft})^2 + (3 \text{ ft}) (2 \text{ ft})^3 - 2 (1 \text{ ft})^2 (3 \text{ ft})^2 + 2 (1 \text{ ft})^2 (2 \text{ ft})^2]$ $= \frac{(226 \text{ lb})}{(1.8 \times 10^8 \text{ lb} \cdot \text{ft}^3)} \times [81 \text{ ft}^4 - 72 \text{ ft}^4 + 24 \text{ ft}^4 - 18 \text{ ft}^4 + 8 \text{ ft}^4]$ $= \left(1.26 \times 10^{-6} \frac{1}{\text{ft}^3} \right) \times [23 \text{ ft}^4]$ $= 0.000029 \text{ ft} \times \frac{12 \text{ in}}{\text{ft}}$ $= 0.00035 \text{ in} \uparrow$	<p>Example 4. Calculate the deflection (Δ) of a single overhanging beam of length (L) and overhang (a) with a concentrated force (F) acting at the free end, at a distance (x), where</p> <p>$w = 1,540 \text{ N/m}$ $L = 1 \text{ m}, a = 0.3 \text{ m}$ $x = 0.6 \text{ m}$ $E = 207 \times 10^9 \text{ N/m}^2 \text{ (steel)}$ $I = 491 \text{ cm}^4$</p> <p>solution</p> <p><i>Step 1.</i> Calculate the stiffness (EI).</p> $EI = (207 \times 10^9 \text{ N/m}^2) (491 \text{ cm}^4)$ $\times \frac{1 \text{ m}^4}{(100 \text{ cm})^4}$ $= 1.02 \times 10^6 \text{ N} \cdot \text{m}^2$ <p><i>Step 2.</i> As the distance (x) is less than the length (L), the deflection (Δ) is determined from Eq. (2.47a).</p> $\Delta = \frac{wx}{24 EIL} (L^4 - 2L^2 x^2 + Lx^3 - 2a^2 L^2 + 2a^2 x^2) \uparrow$ $\Delta = \frac{(1,540 \text{ N/m}) (0.6 \text{ m})}{24 (1.02 \times 10^6 \text{ N} \cdot \text{m}^2) (1 \text{ m})} \times [(1 \text{ m})^4 - 2 (1 \text{ m})^2 (0.6 \text{ m})^2 + (1 \text{ m}) (0.6 \text{ m})^3 - 2 (0.3 \text{ m})^2 (1 \text{ m})^2 + 2 (0.3 \text{ m})^2 (0.6 \text{ m})^2]$ $= \frac{(924 \text{ N})}{(2.45 \times 10^7 \text{ N} \cdot \text{m}^3)} \times [1 \text{ m}^4 - 0.72 \text{ m}^4 + 0.216 \text{ m}^4 - 0.18 \text{ m}^4 + 0.065 \text{ m}^4]$ $= \left(3.77 \times 10^{-5} \frac{1}{\text{m}^3} \right) \times [0.381 \text{ m}^4]$ $= 0.000014 \text{ m} \times \frac{100 \text{ cm}}{\text{m}}$ $= 0.0014 \text{ cm} \uparrow$

Note that the deflection determined in the previous example was positive or upward. For distances closer to the left support, the deflection will be negative or downward. The location of the transition point, meaning the point of zero deflection, is not a simple expression, and depends on the relative values of the length (L) between the supports and the length of the overhang (a).

Unless the length of the overhang (a) is very short compared to the length (L) between the supports, the maximum downward deflection occurs at the tip of the overhang, a distance (x_1) is equal to (a) from the roller support. Substituting (a) for the distance (x_1) in Eq. (2.47b) gives the tip deflection (Δ_{Tip}) as

$$\Delta_{\text{Tip}} = \frac{w}{24EI} (3a^4 + 4a^3L - aL^3) \uparrow \quad (2.48)$$

U.S. Customary	SI/Metric
<p>Example 5. Calculate the maximum downward deflection (Δ_{Tip}) for the beam configuration in Example 4, where</p> <p>$w = 113 \text{ lb/ft}$ $L = 3 \text{ ft}, a = 1 \text{ ft}$ $EI = 2.5 \times 10^6 \text{ lb} \cdot \text{ft}^2$</p> <p>solution The maximum downward deflection (Δ_{Tip}) is given by Eq. (2.48).</p> $\begin{aligned} \Delta_{\text{Tip}} &= \frac{w}{24EI} (3a^4 + 4a^3L - aL^3) \uparrow \\ &= \frac{(113 \text{ lb/ft})}{24(2.5 \times 10^6 \text{ lb} \cdot \text{ft}^2)} \\ &\quad \times [3(1 \text{ ft})^4 + 4(1 \text{ ft})^3(3 \text{ ft}) \\ &\quad - (1 \text{ ft})(3 \text{ ft})^3] \\ &= \frac{113 \text{ lb/ft}}{6.0 \times 10^7 \text{ lb} \cdot \text{ft}^2} \\ &\quad \times [(3 + 12 - 27) \text{ ft}^4] \\ &= \left(1.88 \times 10^{-6} \frac{1}{\text{ft}^3}\right) (-12 \text{ ft}^4) \\ &= -0.000023 \text{ ft} \times \frac{12 \text{ in}}{\text{ft}} \uparrow \\ &= 0.00027 \text{ in} \downarrow \end{aligned}$	<p>Example 5. Calculate the maximum downward deflection (Δ_{Tip}) for the beam configuration in Example 4, where</p> <p>$w = 1,540 \text{ N/m}$ $L = 1 \text{ m}, a = 0.3 \text{ m}$ $EI = 1.02 \times 10^6 \text{ N} \cdot \text{m}^2$</p> <p>solution The maximum downward deflection (Δ_{Tip}) is given by Eq. (2.48).</p> $\begin{aligned} \Delta_{\text{Tip}} &= \frac{w}{24EI} (3a^4 + 4a^3L - aL^3) \uparrow \\ &= \frac{(1,540 \text{ N/m})}{24(1.02 \times 10^6 \text{ N} \cdot \text{m}^2)} \\ &\quad \times [3(0.3 \text{ m})^4 + 4(0.3 \text{ m})^3(1 \text{ m}) \\ &\quad - (0.3 \text{ m})(1 \text{ m})^3] \\ &= \frac{1,540 \text{ N/m}}{2.45 \times 10^7 \text{ N} \cdot \text{m}^2} \\ &\quad \times [(0.0243 + 0.108 - 0.3) \text{ m}^4] \\ &= \left(6.29 \times 10^{-5} \frac{1}{\text{m}^3}\right) (-0.1677 \text{ m}^4) \\ &= -0.00001 \text{ m} \times \frac{100 \text{ cm}}{\text{m}} \uparrow \\ &= 0.001 \text{ cm} \downarrow \end{aligned}$

2.2.9 Double Overhang: Concentrated Forces at Free Ends

The simply-supported beam in Fig. 2.65 has double overhangs with concentrated forces, each of magnitude (F), acting directly downward at the free ends: points A and D . The distance between the supports is labeled (L), and the length of each overhang is labeled (a). Therefore, the total length of the beam, measured from the left end, is ($L + 2a$).



FIGURE 2.65 Double overhang: concentrated forces at free ends.

Reactions. The reactions at the supports are shown in Fig. 2.66—the balanced free-body diagram. The vertical reactions (B_y and C_y) are equal, each with magnitude (F). As both forces are acting directly downward, the horizontal reaction (B_x) is zero.

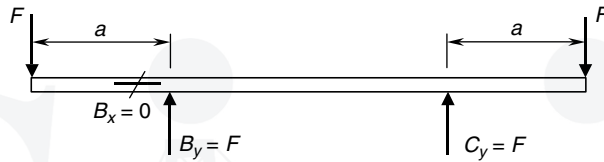

FIGURE 2.66 Free-body diagram.

U.S. Customary	SI/Metric
<p>Example 1. Determine the reactions for a double overhanging beam with concentrated forces at the free ends, both of magnitude (F), with overhangs (a) and a length (L) between the supports, where</p> <p>$F = 1,800 \text{ lb}$ $L = 4 \text{ ft}$ $a = 1.5 \text{ ft}$</p> <p>solution</p> <p><i>Step 1.</i> From Fig. 2.66, calculate the pin reactions (B_x and B_y) at the left support. As the forces are acting directly downward,</p> $B_x = 0$ <p>and the vertical reaction (B_y) is</p> $B_y = F = 1,800 \text{ lb}$ <p><i>Step 2.</i> From Fig. 2.66 calculate the roller reaction (C_y) at the right support.</p> $C_y = F = 1,800 \text{ lb}$	<p>Example 1. Determine the reactions for a double overhanging beam with concentrated forces at the free ends, both of magnitude (F), with overhangs (a) and a length (L) between the supports, where</p> <p>$F = 8,000 \text{ N}$ $L = 1.2 \text{ m}$ $a = 0.5 \text{ m}$</p> <p>solution</p> <p><i>Step 1.</i> From Fig. 2.66 calculate the pin reactions (B_x and B_y) at the left support. As the forces are acting directly downward,</p> $B_x = 0$ <p>and the vertical reaction (B_y) is</p> $B_y = F = 8,000 \text{ N}$ <p><i>Step 2.</i> From Fig. 2.66 calculate the roller reaction (C_y) at the right support.</p> $C_y = F = 8,000 \text{ N}$



FIGURE 2.67 Twin concentrated forces.

Shear Force and Bending Moment Distributions. For the double overhanging beam in Fig. 2.67 with concentrated forces at the ends, each of magnitude (F), and overhangs (a) and a length (L) between the supports, which has the balanced free-body-diagram shown in Fig. 2.68, the shear force (V) distribution is shown in Fig. 2.69.

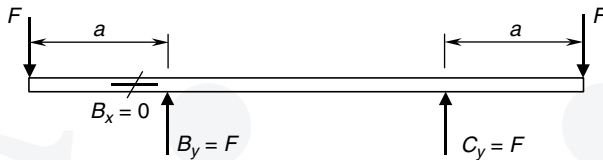

FIGURE 2.68 Free-body-diagram.

Note that the shear force (V) is a negative (F) from the left end of the beam to the left support, zero between the supports, then a positive (F) from the right support to the right end of the beam.

The maximum shear force (V_{max}) is given by Eq. (2.49).

$$V_{max} = F \tag{2.49}$$

The bending moment (M) distribution is given by Eq. (2.50a) for the values of the distance (x) from the left end of the beam to the left support, Eq. (2.50b) between the supports, and Eq. (2.50c) from the right support to the right end of the beam.

(Always measure the distance (x) from the left end of any beam.)

$$M = -Fx \quad 0 \leq x \leq a \tag{2.50a}$$

$$M = -Fa \quad a \leq x \leq L + a \tag{2.50b}$$

$$M = -F(L + 2a - x) \quad L + a \leq x \leq L + 2a \tag{2.50c}$$

The bending moment (M) distribution is shown in Fig. 2.70.

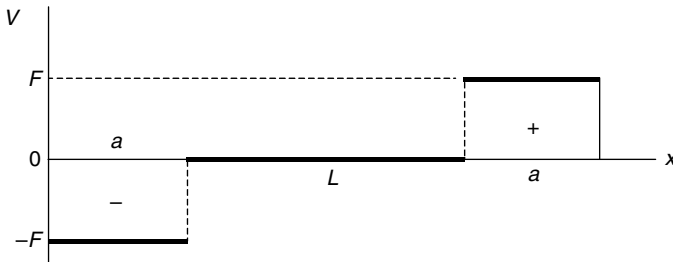

FIGURE 2.69 Shear force diagram.

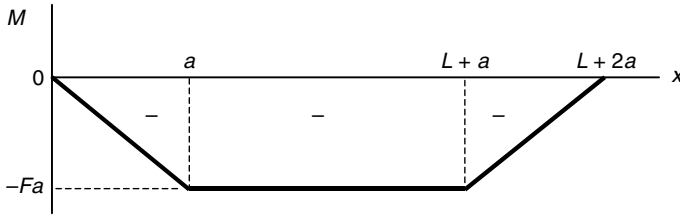

FIGURE 2.70 Bending moment diagram.

Note that the bending moment (M) decreases linearly from zero at the left end of the beam to a value ($-Fa$) at the left support, stays a constant ($-Fa$) between the supports, then increases linearly back to zero at the right end.

The maximum bending moment (M_{\max}) that is always a positive quantity occurs between the supports and is given by Eq. (2.51).

$$M_{\max} = Fa \quad (2.51)$$

U.S. Customary	SI/Metric
<p>Example 2. Calculate the shear force (V) and bending moment (M) for a double overhanging beam with concentrated forces at the free ends, both of magnitude (F), with overhangs (a) and a length (L) between the supports, at a distance (x), where</p> <p>$F = 1,800 \text{ lb}$ $L = 4 \text{ ft}, a = 1.5 \text{ ft}$ $x = 1 \text{ ft}$</p> <p>solution</p> <p><i>Step 1.</i> Note that the distance (x) of 1 ft is to the left of the support at (B),</p> $x \leq a \text{ or } 1\text{ft} \leq 1.5 \text{ ft}$ <p><i>Step 2.</i> Determine the shear force (V) for the distance (x) from Fig. 2.69 as</p> $V = -F = -1,800 \text{ lb}$ <p><i>Step 3.</i> Determine the bending moment (M) for the distance (x) from Eq. (2.50a).</p> $M = -Fx = -(1,800 \text{ lb})(1 \text{ ft})$ $= -1,800 \text{ ft} \cdot \text{lb}$ <p>Example 3. Calculate and locate the maximum shear force (V_{\max}) and the maximum bending moment (M_{\max}) for the beam of Examples 1 and 2, where</p> <p>$F = 1,800 \text{ lb}$ $L = 4 \text{ ft}, a = 1.5 \text{ ft}$</p>	<p>Example 2. Calculate the shear force (V) and bending moment (M) for a double overhanging beam with concentrated forces at the free ends, both of magnitude (F), with overhangs (a) and a length (L) between the supports, at a distance (x), where</p> <p>$F = 8,000 \text{ N}$ $L = 1.2 \text{ m}, a = 0.5 \text{ m}$ $x = 0.3 \text{ m}$</p> <p>solution</p> <p><i>Step 1.</i> Note that the distance (x) of 0.3 m is to the left of the support at (B),</p> $x \leq a \text{ or } 0.3 \text{ m} \leq 0.5 \text{ m}$ <p><i>Step 2.</i> Determine the shear force (V) for the distance (x) from Fig. 2.69 as</p> $V = -F = -8,000 \text{ N}$ <p><i>Step 3.</i> Determine the bending moment (M) for the distance (x) from Eq. (2.50a).</p> $M = -Fx = -(8,000 \text{ N})(0.3 \text{ m})$ $= -2,400 \text{ N} \cdot \text{m}$ <p>Example 3. Calculate and locate the maximum shear force (V_{\max}) and the maximum bending moment (M_{\max}) for the beam of Examples 1 and 2, where</p> <p>$F = 8,000 \text{ N}$ $L = 1.2 \text{ m}, a = 0.5 \text{ m}$</p>

U.S. Customary	SI/Metric
<p>solution</p> <p><i>Step 1.</i> Calculate the maximum shear force (V_{\max}) from Eq. (2.49) as</p> $V_{\max} = F = 1,800 \text{ lb}$ <p><i>Step 2.</i> From Fig. 2.69, the maximum shear force (V_{\max}) occurs in two regions, one from the left end of the beam to the left support, and the other from the right support to the right end of the beam.</p> <p><i>Step 3.</i> Calculate the maximum bending moment (M_{\max}) from Eq. (2.51).</p> $M_{\max} = Fa = (1,800 \text{ lb})(1.5 \text{ ft})$ $= 2,700 \text{ ft} \cdot \text{lb}$ <p><i>Step 4.</i> From Fig. 2.70, the maximum bending moment (M_{\max}) occurs in the region between the two forces.</p>	<p>solution</p> <p><i>Step 1.</i> Calculate the maximum shear force (V_{\max}) from Eq. (2.49) as</p> $V_{\max} = F = 8,000 \text{ N}$ <p><i>Step 2.</i> From Fig. 2.69, the maximum shear force (V_{\max}) occurs in two regions, one from the left end of the beam to the left support, and the other from the right support to the right end of the beam.</p> <p><i>Step 3.</i> Calculate the maximum bending moment (M_{\max}) from Eq. (2.51).</p> $M_{\max} = Fa = (8,000 \text{ N})(0.5 \text{ m})$ $= 4,000 \text{ N} \cdot \text{m}$ <p><i>Step 4.</i> From Fig. 2.70, the maximum bending moment (M_{\max}) occurs in the region between the two forces.</p>

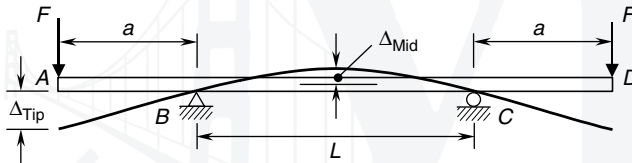

FIGURE 2.71 Beam deflection diagram.

Deflection. For this loading configuration, the deflection along the beam is shown in Fig. 2.71, where the maximum downward deflection (Δ_{Tip}) is given by Eq. (2.52a) and occurs at the tip of either overhang. The maximum upward deflection (Δ_{Mid}) is given by Eq. (2.52b) and occurs at the midpoint of the beam. Note that the deflection curve is symmetrical about the centerline, or middle, of the beam.

$$\Delta_{\text{Tip}} = \frac{Fa^2}{6EI}(3L + 2a) \downarrow \tag{2.52a}$$

$$\Delta_{\text{Mid}} = \frac{FL^2a}{8EI} \uparrow \tag{2.52b}$$

where Δ = deflection of beam

F = concentrated force at each overhang

L = length between supports

a = length of each overhang

E = modulus of elasticity of beam material

I = area moment of inertia of cross-sectional area about axis through centroid

Unless the length (a) is less than about 22 percent of the length (L), the maximum downward deflection (Δ_{Tip}) is greater than the maximum upward deflection (Δ_{Mid}).

U.S. Customary	SI/Metric
<p>Example 4. Calculate the maximum downward deflection (Δ_{Tip}) for a double overhanging beam, with concentrated forces (F) at the free ends, where</p> $F = 1,800 \text{ lb}$ $L = 4 \text{ ft}, a = 1.5 \text{ ft}$ $E = 27.6 \times 10^6 \text{ lb/in}^2 \text{ (stainless steel)}$ $I = 7 \text{ in}^4$ <p>solution</p> <p><i>Step 1.</i> Calculate the stiffness (EI).</p> $EI = (27.6 \times 10^6 \text{ lb/in}^2) (7 \text{ in}^4)$ $= 1.93 \times 10^8 \text{ lb} \cdot \text{in}^2 \times \frac{1 \text{ ft}^2}{144 \text{ in}^2}$ $= 1.34 \times 10^6 \text{ lb} \cdot \text{ft}^2$ <p><i>Step 2.</i> Determine the deflection (Δ_{Tip}) from Eq. (2.52a).</p> $\Delta_{\text{Tip}} = \frac{Fa^2}{6EI} (3L + 2a) \downarrow$ $= \frac{(1,800 \text{ lb}) (1.5 \text{ ft})^2}{6 (1.34 \times 10^6 \text{ lb} \cdot \text{ft}^2)}$ $\times [3 (4 \text{ ft}) + 2 (1.5 \text{ ft})]$ $= \frac{(4,050 \text{ lb} \cdot \text{ft}^2)}{(8.04 \times 10^6 \text{ lb} \cdot \text{ft}^2)} [12 \text{ ft} + 3 \text{ ft}]$ $= (5.04 \times 10^{-4}) \times [15 \text{ ft}]$ $= 0.0076 \text{ ft} \times \frac{12 \text{ in}}{\text{ft}}$ $= 0.09 \text{ in} \downarrow$ <p>Example 5. Calculate the maximum upward deflection (Δ_{Mid}) for a double overhanging beam, with concentrated forces (F) at the free ends, where</p> $F = 1,800 \text{ lb}$ $L = 4 \text{ ft}, a = 1.5 \text{ ft}$ $EI = 1.34 \times 10^6 \text{ lb} \cdot \text{ft}^2$	<p>Example 4. Calculate the maximum downward deflection (Δ_{Tip}) for a double overhanging beam, with concentrated forces (F) at the free ends, where</p> $F = 8,000 \text{ N}$ $L = 1.2 \text{ m}, a = 0.5 \text{ m}$ $E = 190 \times 10^9 \text{ N/m}^2 \text{ (stainless steel)}$ $I = 341 \text{ cm}^4$ <p>solution</p> <p><i>Step 1.</i> Calculate the stiffness (EI).</p> $EI = (190 \times 10^9 \text{ N/m}^2) (341 \text{ cm}^4)$ $\times \frac{1 \text{ m}^4}{(100 \text{ cm})^4}$ $= 6.48 \times 10^5 \text{ N} \cdot \text{m}^2$ <p><i>Step 2.</i> Determine the deflection (Δ_{Tip}) from Eq. (2.52a).</p> $\Delta_{\text{Tip}} = \frac{Fa^2}{6EI} (3L + 2a) \downarrow$ $= \frac{(8,000 \text{ N}) (0.5 \text{ m})^2}{6 (6.48 \times 10^5 \text{ N} \cdot \text{m}^2)}$ $\times [3 (1.2 \text{ m}) + 2 (0.5 \text{ m})]$ $= \frac{(2,000 \text{ N} \cdot \text{m}^2)}{(3.89 \times 10^6 \text{ N} \cdot \text{m}^2)} [3.6 \text{ m} + 1 \text{ m}]$ $= (5.14 \times 10^{-4}) \times [4.6 \text{ m}]$ $= 0.0024 \text{ m} \times \frac{100 \text{ cm}}{\text{m}}$ $= 0.24 \text{ cm} \downarrow$ <p>Example 5. Calculate the maximum upward deflection (Δ_{Mid}) for a double overhanging beam, with concentrated forces (F) at the free ends, where</p> $F = 8,000 \text{ N}$ $L = 1.2 \text{ m}, a = 0.5 \text{ m}$ $EI = 6.48 \times 10^5 \text{ N} \cdot \text{m}^2$

U.S. Customary	SI/Metric
<p>solution Calculate the maximum upward deflection (Δ_{Mid}) from Eq. (2.52b).</p> $\Delta_{Mid} = \frac{FL^2a}{8EI} \uparrow$ $= \frac{(1,800 \text{ lb})(4 \text{ ft})^2(1.5 \text{ ft})}{8(1.34 \times 10^6 \text{ lb} \cdot \text{ft}^2)}$ $= \frac{43,200 \text{ lb} \cdot \text{ft}^3}{(1.07 \times 10^7 \text{ lb} \cdot \text{ft}^2)}$ $= 0.004 \text{ ft} \times \frac{12 \text{ in}}{\text{ft}}$ $= 0.05 \text{ in} \uparrow$	<p>solution Calculate the maximum upward deflection (Δ_{Mid}) from Eq. (2.52b).</p> $\Delta_{Mid} = \frac{FL^2a}{8EI} \uparrow$ $= \frac{(8,000 \text{ N})(1.2 \text{ m})^2(0.5 \text{ m})}{8(6.48 \times 10^5 \text{ N} \cdot \text{m}^2)}$ $= \frac{5,760 \text{ N} \cdot \text{m}^3}{(5.18 \times 10^6 \text{ N} \cdot \text{m}^2)}$ $= 0.0011 \text{ m} \times \frac{100 \text{ cm}}{\text{m}}$ $= 0.11 \text{ cm} \uparrow$

2.2.10 Double Overhang: Uniform Load

The simply-supported beam in Fig. 2.72 has double overhangs, each of length (a). The beam has a uniform distributed load (w) acting vertically downward across the entire length of the beam (L). The units on this distributed load (w) are force per length. Therefore, the total force acting on the beam is the uniform load (w) times the length of the beam (L), or (wL).

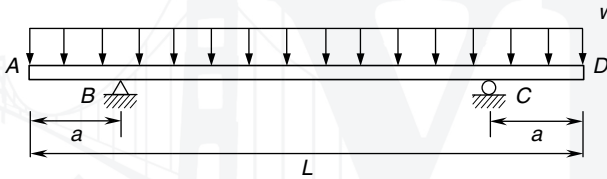

FIGURE 2.72 Double overhang: uniform load.

Reactions. The reactions at the supports are shown in Fig. 2.73—the balanced free-body-diagram. Notice that the total downward force (wL) is split evenly between the vertical reactions (B_y and C_y), and as the uniform load (w) is acting straight down, the horizontal reaction (B_x) is zero.

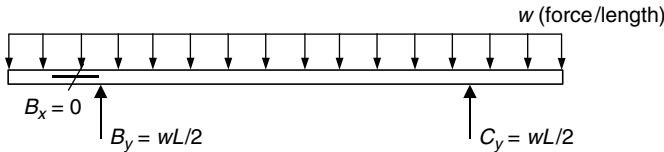

FIGURE 2.73 Free-body-diagram.

U.S. Customary	SI/Metric
<p>Example 1. Determine the reactions for a double overhanging beam of length (L) and overhangs (a) with a uniform distributed load (w), where</p> <p>$w = 15 \text{ lb/ft}$ $L = 12 \text{ ft}$ $a = 2 \text{ ft}$</p>	<p>Example 1. Determine the reactions for a double overhanging beam of length (L) and overhangs (a) with a uniform distributed load (w), where</p> <p>$w = 225 \text{ N/m}$ $L = 4 \text{ m}$ $a = 0.6 \text{ m}$</p>

U.S. Customary	SI/Metric
<p>solution</p> <p><i>Step 1.</i> From Fig. 2.73 calculate the pin reactions (B_x and B_y) at the left support. As the uniform load (w) is vertical,</p> $B_x = 0$ <p>and the vertical reaction (B_y) is</p> $B_y = \frac{wL}{2} = \frac{(15 \text{ lb/ft})(12 \text{ ft})}{2}$ $= \frac{180 \text{ lb}}{2} = 90 \text{ lb}$ <p><i>Step 2.</i> From Fig. 2.73 calculate the roller reaction (B_y) as</p> $C_y = \frac{wL}{2} = \frac{(15 \text{ lb/ft})(12 \text{ ft})}{2}$ $= \frac{180 \text{ lb}}{2} = 90 \text{ lb}$	<p>solution</p> <p><i>Step 1.</i> From Fig. 2.73 calculate the pin reactions (B_x and B_y) at the left support. As the uniform load (w) is vertical,</p> $B_x = 0$ <p>and the vertical reaction (B_y) is</p> $B_y = \frac{wL}{2} = \frac{(225 \text{ N/m})(4 \text{ m})}{2}$ $= \frac{900 \text{ N}}{2} = 450 \text{ N}$ <p><i>Step 2.</i> From Fig. 2.73 calculate the roller reaction (B_y) as</p> $C_y = \frac{wL}{2} = \frac{(225 \text{ N/m})(4 \text{ m})}{2}$ $= \frac{900 \text{ N}}{2} = 450 \text{ N}$

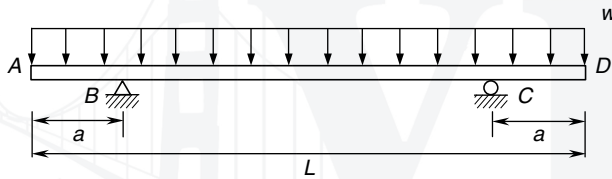

FIGURE 2.74 Uniform load.

Shear Force and Bending Moment Distributions. For the double overhanging beam of length (L) and overhangs (a) with a uniform load (w) acting across the entire beam, shown in Fig. 2.74, which has the balanced free-body diagram as shown in Fig. 2.75, the shear force (V) distribution is shown in Fig. 2.76.

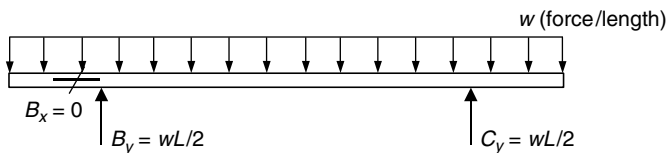

FIGURE 2.75 Free-body diagram.

Note that the shear force (V) starts at zero at the left end of the beam, decreases linearly to a negative (wa) at the left support, then jumps a magnitude ($wL/2$) to a value ($w[L - 2a]/2$), continues to decrease linearly between the supports, crossing zero at the midpoint of the beam, to a negative ($w[L - 2a]/2$) at the right support. Again, the shear force (V) jumps a magnitude ($wL/2$) to a positive (wa), then decreases linearly back to zero at the right end of the beam. So there are discontinuities in the shear force distribution at the supports (B) and (C).

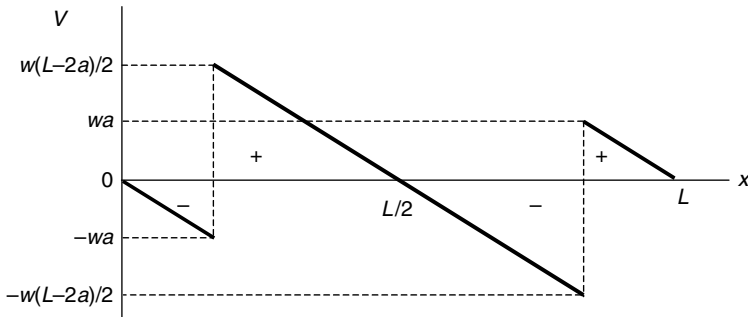

FIGURE 2.76 Shear force diagram.

Mathematically, the shear force distribution is given by Eq. (2.53a) for the values of the distance (x) from the left end of the beam to the pin support at B , Eq. (2.53b) between the supports, and Eq. (2.53c) from the roller support at C to the right end of the beam. (Always measure the distance (x) from the left end of any beam.)

$$V = -wx \quad 0 \leq x \leq a \quad (2.53a)$$

$$V = \frac{w}{2} (L - 2x) \quad a \leq x \leq L - a \quad (2.53b)$$

$$V = w(L - x) \quad L - a \leq x \leq L \quad (2.53c)$$

The maximum shear force (V_{\max}) occurs at the supports and is given by Eq. (2.54)

$$V_{\max} = \frac{w}{2} (L - 2a) \quad (2.54)$$

The bending moment distribution (M) is given by Eq. (2.55a) for the values of the distance (x) from the left end of the beam to the pin support at B , Eq. (2.55b) for the values between the supports, and Eq. (2.55c) for the values from the roller support at C to the right end of the beam.

$$M = -\frac{wx^2}{2} \quad 0 \leq x \leq a \quad (2.55a)$$

$$M = \frac{w}{2} [L(x - a) - x^2] \quad a \leq x \leq L - a \quad (2.55b)$$

$$M = -\frac{w}{2} (L - x)^2 \quad L - a \leq x \leq L \quad (2.55c)$$

The bending moment (M) distribution is shown in Fig. 2.77.

Note that the bending moment (M) is zero at the left end of the beam, decreases quadratically (meaning a power of two) to a maximum negative value at the left support, then increases quadratically to a maximum positive value at the midpoint of the beam, then back to a maximum negative value at the right support, and finally the bending moment increases quadratically back to zero at the right end of the beam.

The maximum negative bending moment ($M_{\max@supports}$) located at the supports is given by Eq. (2.56),

$$M_{\max@supports} = \frac{wa^2}{2} \quad (2.56)$$

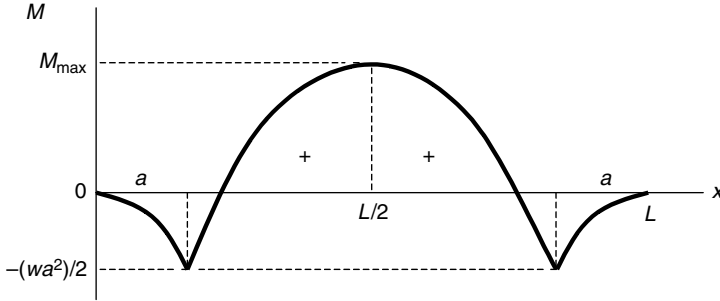

FIGURE 2.77 Bending moment diagram.

and the maximum positive bending moment ($M_{\max@midpoint}$) located at the midpoint of the beam is given by Eq. (2.57),

$$M_{\max@midpoint} = \frac{wL^2}{8} \left[1 - 4 \left(\frac{a}{L} \right) \right] \quad (2.57)$$

Note that the bending moment at the midpoint of the beam will be zero if the overhang (a) is one-fourth the length of the beam (L), that is ($a = L/4$).

U.S. Customary	SI/Metric
<p>Example 2. Calculate the shear force (V) and the bending moment (M) for a double overhanging beam of length (L) and overhangs (a) with a uniform distributed load (w), at a distance (x), where</p> <p>$w = 15 \text{ lb/ft}$ $L = 12 \text{ ft}, a = 2 \text{ ft}$ $x = 4 \text{ ft}$</p> <p>solution</p> <p><i>Step 1.</i> Note that the distance (x) of 4 ft is between the supports,</p> $a \leq x \leq L - a \quad \text{or} \quad 2 \text{ ft} \leq 4 \text{ ft} \leq 10 \text{ ft}$ <p><i>Step 2.</i> As the distance (x) is between the supports, determine the shear force (V) from Eq. (2.53b) as</p> $\begin{aligned} V &= \frac{w}{2} [L - 2x] \\ &= \frac{15 \text{ lb/ft}}{2} [12 \text{ ft} - 2(4 \text{ ft})] \\ &= (7.5 \text{ lb/ft})(12 \text{ ft} - 8 \text{ ft}) \\ &= (7.5 \text{ lb/ft})(4 \text{ ft}) \\ &= 30 \text{ lb} \end{aligned}$	<p>Example 2. Calculate the shear force (V) and bending moment (M) for a double overhanging beam of length (L) and overhangs (a) with a uniform distributed load (w), at a distance (x), where</p> <p>$F = 225 \text{ N/m}$ $L = 4 \text{ m}, a = 0.6 \text{ m}$ $x = 1.2 \text{ m}$</p> <p>solution</p> <p><i>Step 1.</i> Note that the distance (x) of 1.2 m is between the supports,</p> $a \leq x \leq L - a \quad \text{or} \quad 0.6 \text{ m} \leq 1.2 \text{ m} \leq 3.4 \text{ m}$ <p><i>Step 2.</i> As the distance (x) is between the supports, determine the shear force (V) from Eq. (2.53b) as</p> $\begin{aligned} V &= \frac{w}{2} [L - 2x] \\ &= \frac{225 \text{ N/m}}{2} [4 \text{ m} - 2(1.2 \text{ m})] \\ &= (112.5 \text{ N/m})(4 \text{ m} - 2.4 \text{ m}) \\ &= (112.5 \text{ N/m})(1.6 \text{ m}) \\ &= 180 \text{ N} \end{aligned}$

U.S. Customary	SI/Metric
<p><i>Step 3.</i> As the distance (x) is between the supports, determine the bending moment from Eq. (2.55b) as</p> $ \begin{aligned} M &= \frac{w}{2} [L(x-a) - x^2] \\ &= \frac{15 \text{ lb/ft}}{2} [(12 \text{ ft})(4 \text{ ft} - 2 \text{ ft}) \\ &\quad - (4 \text{ ft})^2] \\ &= (7.5 \text{ lb/ft}) [(12)(2) - (16) \text{ ft}^2] \\ &= (7.5 \text{ lb/ft}) [(24 - 16) \text{ ft}^2] \\ &= (7.5 \text{ lb/ft})(8 \text{ ft}^2) = 60 \text{ ft} \cdot \text{lb} \end{aligned} $	<p><i>Step 3.</i> As the distance (x) is between the supports, determine the bending moment from Eq. (2.55b) as</p> $ \begin{aligned} M &= \frac{w}{2} [L(x-a) - x^2] \\ &= \frac{225 \text{ N/m}}{2} [(4 \text{ m})(1.2 \text{ m} - 0.6 \text{ m}) \\ &\quad - (1.2 \text{ m})^2] \\ &= (112.5 \text{ N/m}) [(4)(0.6) - (1.44) \text{ m}^2] \\ &= (112.5 \text{ N/m}) [(2.4 - 1.44) \text{ m}^2] \\ &= (112.5 \text{ N/m})(0.96 \text{ m}^2) = 108 \text{ N} \cdot \text{m} \end{aligned} $
<p>Example 3. Calculate and locate the maximum shear force (V_{\max}) for the beam of Example 2, where</p> <p>$w = 15 \text{ lb/ft}$ $L = 12 \text{ ft}, a = 2 \text{ ft}$</p>	<p>Example 3. Calculate and locate the maximum shear force (V_{\max}) for the beam of Example 2, where</p> <p>$w = 225 \text{ N/m}$ $L = 4 \text{ m}, a = 0.6 \text{ m}$</p>
<p>solution The maximum shear force (V_{\max}) occurs at the supports, given by Eq. (2.54).</p> $ \begin{aligned} V_{\max} &= \frac{w}{2} (L - 2a) \\ &= \frac{15 \text{ lb/ft}}{2} [(12 \text{ ft}) - 2(2 \text{ ft})] \\ &= (7.5 \text{ lb/ft}) [(12 - 4) \text{ ft}] \\ &= (7.5 \text{ lb/ft})(8 \text{ ft}) = 60 \text{ lb} \end{aligned} $	<p>solution The maximum shear force (V_{\max}) occurs at the supports, given by Eq. (2.54).</p> $ \begin{aligned} V_{\max} &= \frac{w}{2} (L - 2a) \\ &= \frac{225 \text{ N/m}}{2} [(4 \text{ m}) - 2(0.6 \text{ m})] \\ &= (112.5 \text{ N/m}) [(4 - 1.2) \text{ m}] \\ &= (112.5 \text{ N/m})(2.8 \text{ m}) = 315 \text{ N} \end{aligned} $
<p>Example 4. Calculate and locate the maximum bending moment (M_{\max}) for the beam of Example 3, where</p> <p>$w = 15 \text{ lb/ft}$ $L = 12 \text{ ft}, a = 2 \text{ ft}$</p>	<p>Example 4. Calculate and locate the maximum bending moment (M_{\max}) for the beam of Example 3, where</p> <p>$w = 225 \text{ N/m}$ $L = 4 \text{ m}, a = 0.6 \text{ m}$</p>
<p>solution The maximum bending moment (M_{\max}) occurs either at the supports, given by Eq. (2.56),</p> $ \begin{aligned} M_{\max @} &= \frac{wa^2}{2} = \frac{(15 \text{ lb/ft})(2 \text{ ft})^2}{2} \\ \text{supports} & \\ &= \frac{(15 \text{ lb/ft})(4 \text{ ft}^2)}{2} \\ &= \frac{60 \text{ ft} \cdot \text{lb}}{2} = 30 \text{ ft} \cdot \text{lb} \end{aligned} $	<p>solution The maximum bending moment (M_{\max}) occurs either at the supports, given by Eq. (2.56),</p> $ \begin{aligned} M_{\max @} &= \frac{wa^2}{2} = \frac{(225 \text{ N/m})(0.6 \text{ m})^2}{2} \\ \text{supports} & \\ &= \frac{(225 \text{ N/m})(0.36 \text{ m}^2)}{2} \\ &= \frac{81 \text{ N} \cdot \text{m}}{2} = 40.5 \text{ N} \cdot \text{m} \end{aligned} $

U.S. Customary	SI/Metric
or at the midpoint of the beam, given by Eq. (2.57),	or at the midpoint of the beam, given by Eq. (2.57).
$M_{\max @ \text{midpoint}} = \frac{wL^2}{8} \left[1 - 4 \left(\frac{a}{L} \right) \right]$ $= \frac{(15 \text{ lb/ft})(12 \text{ ft})^2}{8} \left[1 - 4 \left(\frac{2 \text{ ft}}{12 \text{ ft}} \right) \right]$ $= \frac{(15 \text{ lb/ft})(144 \text{ ft}^2)}{8} \left[1 - 4 \left(\frac{1}{6} \right) \right]$ $= \frac{2,160 \text{ ft} \cdot \text{lb}}{8} \left[1 - \frac{4}{6} \right]$ $= (270 \text{ ft} \cdot \text{lb}) \left[\frac{1}{3} \right]$ $= 90 \text{ ft} \cdot \text{lb}$	$M_{\max @ \text{midpoint}} = \frac{wL^2}{8} \left[1 - 4 \left(\frac{a}{L} \right) \right]$ $= \frac{(225 \text{ N/m})(4 \text{ m})^2}{8} \left[1 - 4 \left(\frac{0.6 \text{ m}}{4 \text{ m}} \right) \right]$ $= \frac{(225 \text{ N/m})(16 \text{ m}^2)}{8} \left[1 - 4 \left(\frac{3}{20} \right) \right]$ $= \frac{3,600 \text{ N} \cdot \text{m}}{8} \left[1 - \frac{3}{5} \right]$ $= (450 \text{ N} \cdot \text{m}) \left[\frac{2}{5} \right]$ $= 180 \text{ N} \cdot \text{m}$

Note that for these relative values of the overhang (a) and the length of the beam (L), the bending moment at the supports is less than the bending moment at the midpoint of the beam. As said earlier, if the overhang (a) is one-fourth the length of the beam (L), that is ($a = L/4$), then the maximum deflection at the midpoint will be zero, and the maximum bending moment at the supports will have a magnitude of $(wL^2/32)$.

Deflection. For this loading configuration, the deflection along the beam has the shape shown in Fig. 2.78.

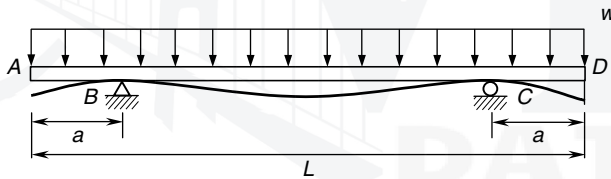

FIGURE 2.78 Beam deflection diagram.

However, formal equations for the deflection of either the overhangs or between the supports are not available. Seems odd, but even *Marks' Standard Handbook for Mechanical Engineers* does not include deflection equations for this beam configuration. The author would greatly appreciate any information regarding where these equations might be found.

This completes the first of the two sections focused on simply-supported beams. In the next section we will present several important cantilevered beams with common loading configurations.

2.3 CANTILEVERED BEAMS

As stated earlier, cantilevered beams like the one shown in Fig. 2.79, have a special type of support at one end, as shown on the left at point A in the figure. The other end of the beam can be free as shown in the right at point B, or can have a roller or pin type support at the other end as shown in Figs. 2.80 and 2.81, respectively.

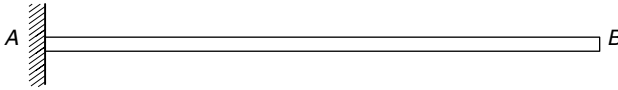

FIGURE 2.79 Cantilevered beam: free end.

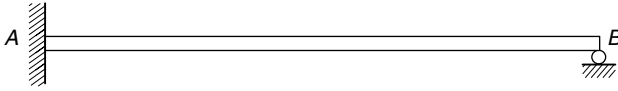

FIGURE 2.80 Cantilevered beam: roller support.

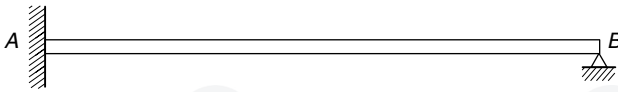

FIGURE 2.81 Cantilevered beam: pin support.

For the idealized symbol at point A , the cantilever support shown in Fig. 2.82a looks like the beam is just stuck to the side of the vertical wall, but it is not. It represents the ability of this type of support, like a pin support, to restrict motion left and right and up and down, but also to restrict rotation, clockwise or counterclockwise.



FIGURE 2.82 Cantilever support symbol and reactions.

As a cantilever support restricts motion in two directions, as well as rotation at the support, the reactions must include two forces and a couple. These are shown as forces A_x and A_y , and couple C_A , in Fig. 2.82b. The magnitude and direction of these forces and couple will depend on the loading configuration, so again, until determined, they are shown in positive directions, where counterclockwise (ccw) rotation is considered positive. (Note: The symbol C is used to indicate a couple to differentiate it from a moment of a force about a point, usually designated by an M , even though both quantities have the same units.)

Examples involving several different types of loadings will be presented for each of these three types of cantilevered beams, to include concentrated forces, concentrated couples, and various distributed loads. Calculations for the reactions, shear force and bending moment distributions, and deflections will be provided in both the U.S. Customary and SI/metric units.

2.3.1 Concentrated Force at Free End

The cantilevered beam shown in Fig. 2.83 has a concentrated force (F) acting vertically downward at its free end that is on the left at point A . The cantilever reaction is on the right end of the beam, at point B . The length of the beam is labeled (L).



FIGURE 2.83 Concentrated force at free end.

Reactions. The reactions at the support are shown in Fig. 2.84—the balanced free-body diagram. Notice that the vertical reaction (B_y) is equal to the force (F), and because the force (F) is acting straight down, the horizontal reaction (B_x) is zero. If the force (F) had a horizontal component, either left or right, then the horizontal reaction (B_x) would be equal, but opposite in direction, to this horizontal component. The couple reaction (C_B) is in a negative direction, meaning clockwise (cw), and equal to a negative of the force (F) times the length of the beam (L).



FIGURE 2.84 Free-body diagram.

U.S. Customary	SI/Metric
<p>Example 1. Determine the reactions for a cantilevered beam of length (L) with a concentrated force (F) acting at its free end, where</p> $F = 150 \text{ lb}$ $L = 8 \text{ ft}$ <p>solution From Fig. 2.84 calculate the reactions (B_x, B_y, and C_B) at the right end of the beam.</p> <p><i>Step 1.</i> As the force (F) is vertical,</p> $B_x = 0$ <p>and</p> $B_y = F = 150 \text{ lb}$ <p><i>Step 2.</i> The couple (C_B) is given by</p> $C_B = -FL = -(150 \text{ lb})(8 \text{ ft})$ $= -1,200 \text{ ft} \cdot \text{lb}$ <p>Note that the minus sign means it is clockwise (cw).</p>	<p>Example 1. Determine the reactions for a cantilevered beam of length (L) with a concentrated force (F) acting at its free end, where</p> $F = 700 \text{ N}$ $L = 2.5 \text{ m}$ <p>solution From Fig. 2.84 calculate the reactions (B_x, B_y, and C_B) at the right end of the beam.</p> <p><i>Step 1.</i> As the force (F) is vertical,</p> $B_x = 0$ <p>and</p> $B_y = F = 700 \text{ N}$ <p><i>Step 2.</i> The couple (C_B) is given by</p> $C_B = -FL = -(700 \text{ N})(2.5 \text{ m})$ $= -1,750 \text{ N} \cdot \text{m}$ <p>Note that the minus sign means it is clockwise (cw).</p>



FIGURE 2.85 Concentrated force at free end.

Shear Force and Bending Moment Distributions. For the cantilevered beam with a concentrated force (F) at its free end, shown in Fig. 2.85, which has the balanced free-body diagram shown in Fig. 2.86, the shear force (V) distribution is shown in Fig. 2.87.

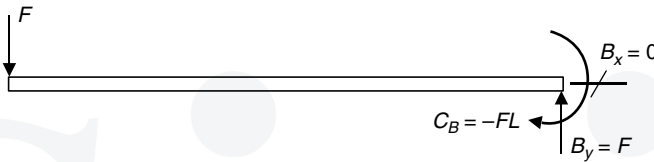

FIGURE 2.86 Free-body diagram.



FIGURE 2.87 Shear force diagram.

Note that the shear force (V) is a negative (F) from the left end of the beam across to the right end of the beam. The maximum shear force (V_{\max}) is therefore

$$V_{\max} = F \quad (2.58)$$

The bending moment distribution is given by Eq. (2.59) for the values of the distance (x) equal to zero at the left end of the beam to a value (L) at the right end of the beam. (Always measure the distance (x) from the left end of any beam.)

$$M = -Fx \quad 0 \leq x \leq L \quad (2.59)$$

The bending moment (M) distribution is shown in Fig. 2.88.

Note that the bending moment (M) is zero at the left end of the beam, where the force (F) acts, then decreases linearly to a maximum negative value ($-FL$) at the right end. The maximum bending moment (M_{\max}) occurs at the right end of the beam and is given by Eq. (2.60).

$$M_{\max} = FL \quad (2.60)$$

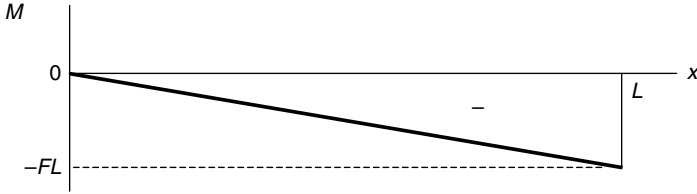

FIGURE 2.88 Bending moment diagram.

U.S. Customary	SI/Metric
<p>Example 2. Calculate the shear force (V) and bending moment (M) for a cantilevered beam of length (L) with a concentrated force (F) acting at its free end, at a distance (x) from the left end of the beam, where</p> $F = 150 \text{ lb}$ $L = 8 \text{ ft}$ $x = 3 \text{ ft}$ <p>solution</p> <p><i>Step 1.</i> Determine the shear force (V) from Fig. 2.87 as</p> $V = -F = -150 \text{ lb}$ <p><i>Step 2.</i> Determine the bending moment (M) from Eq. (2.59).</p> $M = -Fx = -(150 \text{ lb})(3 \text{ ft})$ $= -450 \text{ ft} \cdot \text{lb}$ <p>Example 3. Calculate and locate the maximum shear force (V_{\max}) and the maximum bending moment (M_{\max}) for the beam of Examples 1 and 2, where</p> $F = 150 \text{ lb}$ $L = 8 \text{ ft}$ <p>solution</p> <p><i>Step 1.</i> Calculate the maximum shear force (V_{\max}) from Eq. (2.58) as</p> $V_{\max} = F = 150 \text{ lb}$ <p><i>Step 2.</i> Figure 2.87 shows that this maximum shear force (V_{\max}) of 150 lb does not have a specific location.</p> <p><i>Step 3.</i> Calculate the maximum bending moment (M_{\max}) from Eq. (2.60) as</p> $M_{\max} = FL = (150 \text{ lb})(8 \text{ ft})$ $= 1,200 \text{ ft} \cdot \text{lb}$	<p>Example 2. Calculate the shear force (V) and bending moment (M) for a cantilevered beam of length (L) with a concentrated force (F) acting at its free end, at a distance (x) from the left end of the beam, where</p> $F = 700 \text{ N}$ $L = 2.5 \text{ m}$ $x = 1 \text{ m}$ <p>solution</p> <p><i>Step 1.</i> Determine the shear force (V) from Fig. 2.87 as</p> $V = -F = -700 \text{ N}$ <p><i>Step 2.</i> Determine the bending moment (M) from Eq. (2.59).</p> $M = -Fx = -(700 \text{ N})(1 \text{ m})$ $= -700 \text{ N} \cdot \text{m}$ <p>Example 3. Calculate and locate the maximum shear force (V_{\max}) and the maximum bending moment (M_{\max}) for the beam of Examples 1 and 2, where</p> $F = 700 \text{ N}$ $L = 2.5 \text{ m}$ <p>solution</p> <p><i>Step 1.</i> Calculate the maximum shear force (V_{\max}) from Eq. (2.58) as</p> $V_{\max} = F = 700 \text{ N}$ <p><i>Step 2.</i> As shown in Fig. 2.87, this maximum shear force (V_{\max}) of 700 N does not have a specific location.</p> <p><i>Step 3.</i> Calculate the maximum bending moment (M_{\max}) from Eq. (2.60) as</p> $M_{\max} = FL = (700 \text{ N})(2.5 \text{ m})$ $= 1,750 \text{ N} \cdot \text{m}$

U.S. Customary	SI/Metric
<p><i>Step 4.</i> As shown in Fig. 2.88, this maximum bending moment (M_{\max}) of 1,200 ft · lb is located at the right end of the beam, meaning at the wall support.</p>	<p><i>Step 4.</i> Figure 2.88 shows that this maximum bending moment (M_{\max}) of 1,750 N · m is located at the right end of the beam, that is, at the wall support.</p>

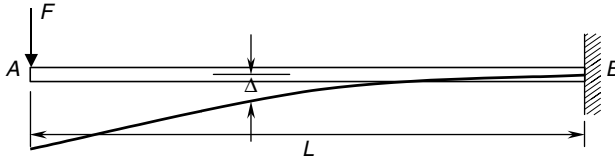

FIGURE 2.89 Beam deflection diagram.

Deflection. For this loading configuration, the deflection (Δ) along the beam is shown in Fig. 2.89, and given by Eq. (2.61) for values of the distance (x) from the left end of the beam, as

$$\Delta = \frac{F}{6EI}(2L^3 - 3L^2x + x^3) \quad 0 \leq x \leq L \quad (2.61)$$

where Δ = deflection of beam

F = applied force at the free end of beam

x = distance from left end of beam

L = length of beam

E = modulus of elasticity of beam material

I = area moment of inertia of cross-sectional area about axis through centroid

The maximum deflection (Δ_{\max}) occurs at the free end, and is given by Eq. (2.62),

$$\Delta_{\max} = \frac{FL^3}{3EI} \quad \text{at } x = 0 \quad (2.62)$$

For most gravity driven loading configurations, the value for the deflection (Δ) at any location along the beam is usually downward. However, many loading configurations produce deflections that are upward, and still others produce deflections that are both upward and downward, depending on the location and nature of the loads along the length of the beam.

U.S. Customary	SI/Metric
<p>Example 4. Calculate the deflection (Δ) for a cantilevered beam of length (L) with a concentrated force (F) acting at its free end, at a distance (x) from the left end of the beam, where</p> <p>$F = 150$ lb $L = 8$ ft $x = 3$ ft $E = 1.6 \times 10^6$ lb/in² (Douglas fir) $I = 145$ in⁴</p>	<p>Example 4. Calculate the deflection (Δ) for a cantilevered beam of length (L) with a concentrated force (F) acting at its free end, at a distance (x) from the left end of the beam, where</p> <p>$F = 700$ N $L = 2.5$ m $x = 1$ m $E = 11 \times 10^9$ N/m² (Douglas fir) $I = 6,035$ cm⁴</p>

U.S. Customary	SI/Metric
<p>solution</p> <p><i>Step 1.</i> Calculate the stiffness (EI).</p> $EI = (1.6 \times 10^6 \text{ lb/in}^2) (145 \text{ in}^4)$ $= 2.32 \times 10^8 \text{ lb} \cdot \text{in}^2 \times \frac{1 \text{ ft}^2}{144 \text{ in}^2}$ $= 1.61 \times 10^6 \text{ lb} \cdot \text{ft}^2$ <p><i>Step 2.</i> Determine the deflection (Δ) from Eq. (2.61).</p> $\Delta = \frac{F}{6(EI)} (2L^3 - 3L^2x + x^3)$ $= \frac{(150 \text{ lb})}{6 (1.61 \times 10^6 \text{ lb} \cdot \text{ft}^2)} \times [2(8 \text{ ft})^3 - 3(8 \text{ ft})^2(3 \text{ ft}) + (3 \text{ ft})^3]$ $\Delta = \frac{(150 \text{ lb})}{(9.66 \times 10^6 \text{ lb} \cdot \text{ft}^2)} \times [(1024 - 576 + 27) \text{ ft}^3]$ $= \left(1.553 \times 10^{-5} \frac{1}{\text{ft}^2}\right) \times (475 \text{ ft}^3)$ $= 0.0074 \text{ ft} \times \frac{12 \text{ in}}{\text{ft}} = 0.09 \text{ in} \downarrow$	<p>solution</p> <p><i>Step 1.</i> Calculate the stiffness (EI).</p> $EI = (11 \times 10^9 \text{ N/m}^2) (6,035 \text{ cm}^4)$ $\times \frac{1 \text{ m}^4}{(100 \text{ cm})^4}$ $= 6.64 \times 10^5 \text{ N} \cdot \text{m}^2$ <p><i>Step 2.</i> Determine the deflection (Δ) from Eq. (2.61).</p> $\Delta = \frac{F}{6(EI)} (2L^3 - 3L^2x + x^3)$ $= \frac{(700 \text{ N})}{6 (6.64 \times 10^5 \text{ N} \cdot \text{m}^2)} [2(2.5 \text{ m})^3 - 3(2.5 \text{ m})^2(1 \text{ m}) + (1 \text{ m})^3]$ $\Delta = \frac{(700 \text{ N})}{(3.98 \times 10^6 \text{ N} \cdot \text{m}^2)} \times [(31.25 - 18.75 + 1) \text{ m}^3]$ $= \left(1.76 \times 10^{-4} \frac{1}{\text{m}^2}\right) \times (13.5 \text{ m}^3)$ $= 0.0024 \text{ m} \times \frac{100 \text{ cm}}{\text{m}} = 0.24 \text{ cm} \downarrow$
<p>Example 5. Calculate the maximum deflection (Δ_{\max}) and its location for the beam configuration in Example 4, where</p> $F = 150 \text{ lb}$ $L = 8 \text{ ft}$ $EI = 1.61 \times 10^6 \text{ lb} \cdot \text{ft}^2$	<p>Example 5. Calculate the maximum deflection (Δ_{\max}) and its location for the beam configuration in Example 4, where</p> $F = 700 \text{ N}$ $L = 2.5 \text{ m}$ $EI = 6.64 \times 10^5 \text{ N} \cdot \text{m}^2$
<p>solution</p> <p><i>Step 1.</i> Calculate the maximum deflection at the free end from Eq. (2.62).</p> $\Delta_{\max} = \frac{FL^3}{3(EI)}$ $= \frac{(150 \text{ lb})(8 \text{ ft})^3}{3(1.61 \times 10^6 \text{ lb} \cdot \text{ft}^2)}$ $= \frac{7.68 \times 10^4 \text{ lb} \cdot \text{ft}^3}{4.83 \times 10^6 \text{ lb} \cdot \text{ft}^2}$ $= 0.0159 \text{ ft} \times \frac{12 \text{ in}}{\text{ft}} = 0.19 \text{ in} \downarrow$	<p>solution</p> <p><i>Step 1.</i> Calculate the maximum deflection at the free end from Eq. (2.62).</p> $\Delta_{\max} = \frac{FL^3}{3(EI)}$ $= \frac{(700 \text{ N})(2.5 \text{ m})^3}{3(6.64 \times 10^5 \text{ N} \cdot \text{m}^2)}$ $= \frac{1.09 \times 10^4 \text{ N} \cdot \text{m}^3}{1.99 \times 10^6 \text{ N} \cdot \text{m}^2}$ $= 0.0055 \text{ m} \times \frac{100 \text{ cm}}{\text{m}} = 0.55 \text{ cm} \downarrow$

2.3.2 Concentrated Force at Intermediate Point

The cantilevered beam shown in Fig. 2.90 has a concentrated force (F) acting vertically downward at an intermediate point, a distance (a) from the left end of the beam. The cantilever reaction is on the right end of the beam, at point B . The length of the beam is labeled (L).

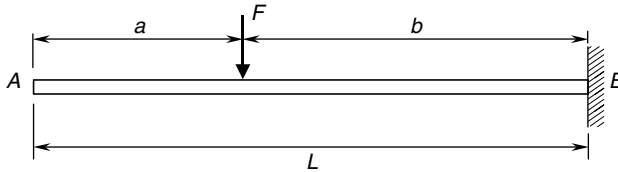

FIGURE 2.90 Concentrated force at intermediate point.

Reactions. The reactions at the support are shown in Fig. 2.91—the balanced free-body diagram. Notice that the vertical reaction (B_y) is equal to the force (F), and because the force (F) is acting straight down, the horizontal reaction (B_x) is zero. If the force (F) had a horizontal component, either left or right, then the horizontal reaction (B_x) would be equal, but opposite in direction to this horizontal component. The couple reaction (C_B) is in a negative direction, meaning clockwise (cw), and equal to a negative of the force (F) times the length (b) that is the distance from the force to the wall at B .



FIGURE 2.91 Free-body diagram.

U.S. Customary	SI/Metric
<p>Example 1. Determine the reactions for a cantilevered beam of length (L) with a concentrated force (F) acting at an intermediate point, where</p> <p>$F = 150$ lb $L = 8$ ft $a = 3$ ft, $b = 5$ ft</p> <p>solution From Fig. 2.91 calculate the reactions (B_x, B_y, and C_B) at the right end of the beam.</p> <p><i>Step 1.</i> As the force (F) is vertical,</p> $B_x = 0$ <p>and</p> $B_y = F = 150$ lb	<p>Example 1. Determine the reactions for a cantilevered beam of length (L) with a concentrated force (F) acting at an intermediate point, where</p> <p>$F = 700$ N $L = 2.5$ m $a = 1$ m, $b = 1.5$ m</p> <p>solution From Fig. 2.91 calculate the reactions (B_x, B_y, and C_B) at the right end of the beam.</p> <p><i>Step 1.</i> As the force (F) is vertical,</p> $B_x = 0$ <p>and</p> $B_y = F = 700$ N

U.S. Customary	SI/Metric
<p>Step 2. The couple (C_B) is given by</p> $C_B = -Fb = -(150 \text{ lb})(5 \text{ ft})$ $= -750 \text{ ft} \cdot \text{lb}$ <p>Note that the minus sign means it is clockwise (cw).</p>	<p>Step 2. The couple (C_B) is given by</p> $C_B = -Fb = -(700 \text{ N})(1.5 \text{ m})$ $= -1,050 \text{ N} \cdot \text{m}$ <p>Note that the minus sign means it is clockwise (cw).</p>

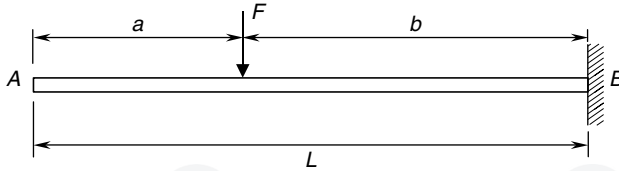

FIGURE 2.92 Concentrated force at intermediate point.

Shear Force and Bending Moment Distributions. For the cantilevered beam with a concentrated force (F) at an intermediate point, shown in Fig. 2.92, which has the balanced free-body-diagram as shown in Fig. 2.93, the shear force (V) distribution is shown in Fig. 2.94.



FIGURE 2.93 Free-body-diagram.

Note that the shear force (V) is zero from the left end of the beam to the location of the concentrated force (F), at a distance (a). At this point the shear force drops to a constant negative value (F) and continues at this value to the right end of the beam. The maximum shear force (V_{\max}) is therefore

$$V_{\max} = F \tag{2.63}$$

The bending moment (M) is also zero from the left end of the beam to the location of the concentrated force (F). At this point the bending moment (M) starts to decrease linearly

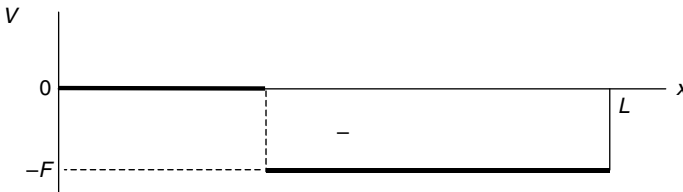

FIGURE 2.94 Shear force diagram.

according to Eq. (2.64) to a maximum negative value ($-Fb$) at the right end of the beam. (Always measure the distance (x) from the left end of any beam.)

$$M = -F(x - a) \quad a \leq x \leq L \quad (2.64)$$

The bending moment (M) distribution is shown in Fig. 2.95.

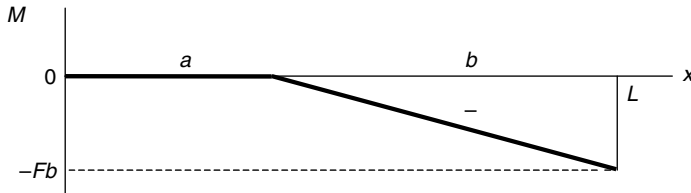

FIGURE 2.95 Bending moment diagram.

The maximum bending moment (M_{\max}) occurs at the right end of the beam and is given by Eq. (2.65).

$$M_{\max} = Fb \quad (2.65)$$

U.S. Customary	SI/Metric
<p>Example 2. Calculate the shear force (V) and bending moment (M) for a cantilevered beam of length (L) with a concentrated force (F) acting at an intermediate point, at a distance (x) from the left end of the beam, where</p> <p>$F = 150 \text{ lb}$ $L = 8 \text{ ft}$ $a = 3 \text{ ft}, b = 5 \text{ ft}$ $x = 6 \text{ ft}$</p> <p>solution <i>Step 1.</i> As the distance (x) is greater than the distance (a) to the force (F), the shear force (V) from Fig. 2.94 is</p> $V = -F = -150 \text{ lb}$ <p><i>Step 2.</i> Again, because the distance (x) is greater than (a), the bending moment (M) is determined from Eq. (2.64).</p> $\begin{aligned} M &= -F(x - a) \\ &= -(150 \text{ lb})(6 \text{ ft} - 3 \text{ ft}) \\ &= -(150 \text{ lb})(3 \text{ ft}) \\ &= -450 \text{ ft} \cdot \text{lb} \end{aligned}$	<p>Example 2. Calculate the shear force (V) and bending moment (M) for a cantilevered beam of length (L) with a concentrated force (F) acting at an intermediate point, at a distance (x) from the left end of the beam, where</p> <p>$F = 700 \text{ N}$ $L = 2.5 \text{ m}$ $a = 1 \text{ m}, b = 1.5 \text{ m}$ $x = 2 \text{ m}$</p> <p>solution <i>Step 1.</i> As the distance (x) is greater than the distance (a) to the force (F), the shear force (V) from Fig. 2.94 is</p> $V = -F = -700 \text{ N}$ <p><i>Step 2.</i> Again, as the distance (x) is greater than (a), the bending moment (M) is determined from Eq. (2.64).</p> $\begin{aligned} M &= -F(x - a) \\ &= -(700 \text{ N})(2 \text{ m} - 1 \text{ m}) \\ &= -(700 \text{ N})(1 \text{ m}) \\ &= -700 \text{ N} \cdot \text{m} \end{aligned}$

U.S. Customary	SI/Metric
<p>Example 3. Calculate and locate the maximum shear force (V_{\max}) and the maximum bending moment (M_{\max}) for the beam of Examples 1 and 2, where</p> <p>$F = 150$ lb $L = 8$ ft $a = 3$ ft, $b = 5$ ft</p> <p>solution</p> <p><i>Step 1.</i> Calculate the maximum shear force (V_{\max}) from Eq. (2.63) as</p> $V_{\max} = F = 150 \text{ lb}$ <p><i>Step 2.</i> As shown in Fig. 2.94 this maximum shear force (V_{\max}) of 150 lb occurs in the region to the right of the force (F).</p> <p><i>Step 3.</i> Calculate the maximum bending moment (M_{\max}) from Eq. (2.65) as</p> $\begin{aligned} M_{\max} &= Fb = (150 \text{ lb})(5 \text{ ft}) \\ &= 750 \text{ ft} \cdot \text{lb} \end{aligned}$ <p><i>Step 4.</i> As shown in Fig. 2.95 this maximum bending moment (M_{\max}) of 750 ft · lb is located at the right end of the beam, that is at the wall support.</p>	<p>Example 3. Calculate and locate the maximum shear force (V_{\max}) and the maximum bending moment (M_{\max}) for the beam of Examples 1 and 2, where</p> <p>$F = 700$ N $L = 2.5$ m $a = 1$ m, $b = 1.5$ m</p> <p>solution</p> <p><i>Step 1.</i> Calculate the maximum shear force (V_{\max}) from Eq. (2.63) as</p> $V_{\max} = F = 700 \text{ N}$ <p><i>Step 2.</i> As shown in Fig. 2.94, this maximum shear force (V_{\max}) of 150 lb occurs in the region to the right of the force (F).</p> <p><i>Step 3.</i> Calculate the maximum bending moment (M_{\max}) from Eq. (2.65) as</p> $\begin{aligned} M_{\max} &= Fb = (700 \text{ N})(1.5 \text{ m}) \\ &= 1,050 \text{ N} \cdot \text{m} \end{aligned}$ <p><i>Step 4.</i> As shown in Fig. 2.95, this maximum bending moment (M_{\max}) of 1,050 N · m is located at the right end of the beam, meaning at the wall support.</p>

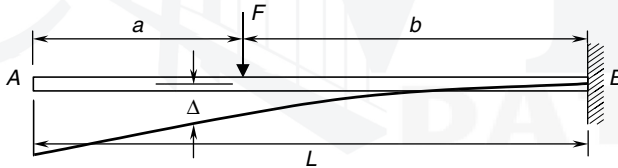

FIGURE 2.96 Beam deflection diagram.

Deflection. For this loading configuration, the deflection (Δ) along the beam is shown in Fig. 2.96, and given by Eq. (2.66a) for the values of the distance (x) from the left end of the beam to the location of the force (F), at distance (a), and by Eq. (2.66b) for the values of distance (x) from the force (F) to the right end of the beam.

$$\Delta = \frac{Fb^2}{6EI} (3L - 3x - b) \quad 0 \leq x \leq a \quad (2.66a)$$

$$\Delta = \frac{F(L-x)^2}{6EI} (3b - L + x) \quad a \leq x \leq L \quad (2.66b)$$

where Δ = deflection of beam

F = applied force at intermediate point

x = distance from left end of beam

L = length of beam

a = distance to force (F) from left end of beam

b = distance from force (F) to right end of beam

E = modulus of elasticity of beam material

I = area moment of inertia of cross-sectional area about axis through centroid

The maximum deflection (Δ_{\max}) occurs at the free end, and is given by Eq. (2.67),

$$\Delta_{\max} = \frac{Fb^2}{6EI}(3L - b) \quad \text{at } x = 0 \quad (2.67)$$

and deflection (Δ_a) at the location of the force (F) is given by Eq. (2.68),

$$\Delta_a = \frac{Fb^3}{3EI} \quad \text{at } x = a \quad (2.68)$$

U.S. Customary	SI/Metric
<p>Example 4. Calculate the deflection (Δ) for a cantilevered beam of length (L) with a concentrated force (F) acting at an intermediate point, at a distance (x) from the left end of the beam, where</p> <p>$F = 150 \text{ lb}$ $L = 8 \text{ ft}$ $a = 3 \text{ ft}, b = 5 \text{ ft}$ $x = 6 \text{ ft}$ $E = 1.6 \times 10^6 \text{ lb/in}^2$ (Douglas fir) $I = 145 \text{ in}^4$</p> <p>solution <i>Step 1.</i> Calculate the stiffness (EI).</p> $EI = (1.6 \times 10^6 \text{ lb/in}^2)(145 \text{ in}^4)$ $= 2.32 \times 10^8 \text{ lb} \cdot \text{in}^2 \times \frac{1 \text{ ft}^2}{144 \text{ in}^2}$ $= 1.61 \times 10^6 \text{ lb} \cdot \text{ft}^2$ <p><i>Step 2.</i> As the distance (x) is greater than the distance (a), determine the deflection (Δ) from Eq. (2.66b).</p> $\Delta = \frac{F(L-x)^2}{6(EI)}(3b - L + x)$ $= \frac{(150 \text{ lb})(8 \text{ ft} - 6 \text{ ft})^2}{6(1.61 \times 10^6 \text{ lb} \cdot \text{ft}^2)}$ $\times [3(5 \text{ ft}) - (8 \text{ ft}) + (6 \text{ ft})]$ $= \frac{(600 \text{ lb} \cdot \text{ft}^2)}{(9.66 \times 10^6 \text{ lb} \cdot \text{ft}^2)}$ $\times [(15 - 8 + 6) \text{ ft}]$ $= (6.21 \times 10^{-5}) \times (13 \text{ ft})$ $= 0.00081 \text{ ft} \times \frac{12 \text{ in}}{\text{ft}}$ $= 0.010 \text{ in} \downarrow$	<p>Example 4. Calculate the deflection (Δ) for a cantilevered beam of length (L) with a concentrated force (F) acting at an intermediate point, at a distance (x) from the left end of the beam, where</p> <p>$F = 700 \text{ N}$ $L = 2.5 \text{ m}$ $a = 1 \text{ m}, b = 1.5 \text{ m}$ $x = 2 \text{ m}$ $E = 11 \times 10^9 \text{ N/m}^2$ (Douglas fir) $I = 6,035 \text{ cm}^4$</p> <p>solution <i>Step 1.</i> Calculate the stiffness (EI).</p> $EI = (11 \times 10^9 \text{ N/m}^2)(6,035 \text{ cm}^4)$ $\times \frac{1 \text{ m}^4}{(100 \text{ cm})^4}$ $= 6.64 \times 10^5 \text{ N} \cdot \text{m}^2$ <p><i>Step 2.</i> As the distance (x) is greater than the distance (a), determine the deflection (Δ) from Eq. (2.66b).</p> $\Delta = \frac{F(L-x)^2}{6(EI)}(3b - L + x)$ $= \frac{(700 \text{ N})(2.5 \text{ m} - 2 \text{ m})^2}{6(6.64 \times 10^5 \text{ N} \cdot \text{m}^2)}$ $\times [3(1.5 \text{ m}) - (2.5 \text{ m}) + (2 \text{ m})]$ $= \frac{(175 \text{ N} \cdot \text{m}^2)}{(3.98 \times 10^6 \text{ N} \cdot \text{m}^2)}$ $\times [(4.5 - 2.5 + 2) \text{ m}]$ $= (4.39 \times 10^{-5}) \times (4 \text{ m})$ $= 0.00018 \text{ m} \times \frac{100 \text{ cm}}{\text{m}}$ $= 0.018 \text{ cm} \downarrow$

U.S. Customary	SI/Metric
<p>Example 5. Calculate the maximum deflection (Δ_{\max}) and its location for the beam configuration in Example 4, where</p> $F = 150 \text{ lb}$ $L = 8 \text{ ft}$ $a = 3 \text{ ft}, b = 5 \text{ ft}$ $EI = 1.61 \times 10^6 \text{ lb} \cdot \text{ft}^2$ <p>solution</p> <p><i>Step 1.</i> Calculate the maximum deflection at the free end from Eq. (2.67).</p> $\begin{aligned} \Delta_{\max} &= \frac{Fb^2}{6(EI)} (3L - b) \\ &= \frac{(150 \text{ lb})(5 \text{ ft})^2}{6(1.61 \times 10^6 \text{ lb} \cdot \text{ft}^2)} \\ &\quad \times [3(8 \text{ ft}) - 5 \text{ ft}] \\ &= \frac{3.75 \times 10^3 \text{ lb} \cdot \text{ft}^2}{9.66 \times 10^6 \text{ lb} \cdot \text{ft}^2} \\ &\quad \times [(24 - 5) \text{ ft}] \\ &= (3.88 \times 10^{-4}) \times (19 \text{ ft}) \\ &= 0.00737 \text{ ft} \times \frac{12 \text{ in}}{\text{ft}} \\ &= 0.088 \text{ in} \downarrow \end{aligned}$	<p>Example 5. Calculate the maximum deflection (Δ_{\max}) and its location for the beam configuration in Example 4, where</p> $F = 700 \text{ N}$ $L = 2.5 \text{ m}$ $a = 1 \text{ m}, b = 1.5 \text{ m}$ $EI = 6.64 \times 10^5 \text{ N} \cdot \text{m}^2$ <p>solution</p> <p><i>Step 1.</i> Calculate the maximum deflection at the free end from Eq. (2.67).</p> $\begin{aligned} \Delta_{\max} &= \frac{Fb^2}{6(EI)} (3L - b) \\ &= \frac{(700 \text{ N})(1.5 \text{ m})^2}{6(6.64 \times 10^5 \text{ N} \cdot \text{m}^2)} \\ &\quad \times [3(2.5 \text{ m}) - 1.5 \text{ m}] \\ &= \frac{1.575 \times 10^3 \text{ N} \cdot \text{m}^2}{3.98 \times 10^6 \text{ N} \cdot \text{m}^2} \\ &\quad \times [(7.5 - 1.5) \text{ m}] \\ &= (3.96 \times 10^{-4}) \times (6 \text{ m}) \\ &= 0.00237 \text{ m} \times \frac{100 \text{ cm}}{\text{m}} \\ &= 0.237 \text{ cm} \downarrow \end{aligned}$
<p>Example 6. Calculate the deflection (Δ_a) where the force (F) acts, where</p> $F = 150 \text{ lb}$ $L = 8 \text{ ft}$ $a = 3 \text{ ft}, b = 5 \text{ ft}$ $EI = 1.61 \times 10^6 \text{ lb} \cdot \text{ft}^2$ <p>solution</p> <p><i>Step 1.</i> Calculate the deflection (Δ_a) where the force (F) acts from Eq. (2.68).</p> $\begin{aligned} \Delta_a &= \frac{Fb^3}{3(EI)} \\ &= \frac{(150 \text{ lb})(5 \text{ ft})^3}{3(1.61 \times 10^6 \text{ lb} \cdot \text{ft}^2)} \\ &= \frac{1.875 \times 10^4 \text{ lb} \cdot \text{ft}^3}{4.83 \times 10^6 \text{ lb} \cdot \text{ft}^2} \\ &= 0.0039 \text{ ft} \times \frac{12 \text{ in}}{\text{ft}} \\ &= 0.047 \text{ in} \downarrow \end{aligned}$	<p>Example 6. Calculate the deflection (Δ_a) where the force (F) acts, where</p> $F = 700 \text{ N}$ $L = 2.5 \text{ m}$ $a = 1 \text{ m}, b = 1.5 \text{ m}$ $EI = 6.64 \times 10^5 \text{ N} \cdot \text{m}^2$ <p>solution</p> <p><i>Step 1.</i> Calculate the deflection (Δ_a) where the force (F) acts from Eq. (2.68).</p> $\begin{aligned} \Delta_a &= \frac{Fb^3}{3(EI)} \\ &= \frac{(700 \text{ N})(1.5 \text{ m})^3}{3(6.64 \times 10^5 \text{ N} \cdot \text{m}^2)} \\ &= \frac{2.363 \times 10^3 \text{ N} \cdot \text{m}^3}{1.99 \times 10^6 \text{ N} \cdot \text{m}^2} \\ &= 0.00119 \text{ m} \times \frac{100 \text{ cm}}{\text{m}} \\ &= 0.119 \text{ cm} \downarrow \end{aligned}$

2.3.3 Concentrated Couple

The cantilevered beam shown in Fig. 2.97 has an applied couple (C) acting clockwise (cw) at a distance (a) from the cantilevered support at point A . The distance from the couple to the free end of the beam at point B is labeled (b), and the total length of the beam is labeled (L).

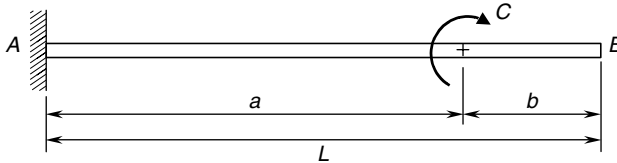

FIGURE 2.97 Concentrated couple.

Reactions. The reactions at the support are shown in Fig. 2.98—the balanced free-body diagram. As the only load on the beam is a couple, the horizontal and vertical reactions (A_x and A_y) are equal to zero, and the couple reaction (C_A) is equal to magnitude of the applied couple (C), but opposite to its direction, meaning counterclockwise (ccw). (Recall that counterclockwise is considered positive.)

The location of the applied couple (C) along the beam does not affect the reactions or the shear force distribution, but only affects the bending moment distribution and the shape of the deflection curve.

U.S. Customary	SI/Metric
<p>Example 1. Determine the reactions for a cantilevered beam of length (L) with an applied couple (C) acting at a distance (a) from the support, where</p> $C = 1,500 \text{ ft} \cdot \text{lb}$ $L = 4 \text{ ft}$ $a = 3 \text{ ft}, b = 1 \text{ ft}$ <p>solution From Fig. 2.98 calculate the reactions (A_x, A_y, and C_A) at the left end of the beam.</p> <p><i>Step 1.</i> As the couple (C) is the only load acting on the beam,</p> $A_x = 0$ <p>and</p> $A_y = 0$ <p><i>Step 2.</i> Therefore the couple (C_A) is</p> $C_A = C = 1,500 \text{ ft} \cdot \text{lb}$ <p>Note that as (C_A) is positive, this means it is counterclockwise (ccw).</p>	<p>Example 1. Determine the reactions for a cantilevered beam of length (L) with an applied couple (C) acting at a distance (a) from the support, where</p> $C = 2,000 \text{ N} \cdot \text{m}$ $L = 1.2 \text{ m}$ $a = 0.9 \text{ m}, b = 0.3 \text{ m}$ <p>solution From Fig. 2.98 calculate the reactions (A_x, A_y, and C_A) at the left end of the beam.</p> <p><i>Step 1.</i> As the couple (C) is the only load acting on the beam,</p> $A_x = 0$ <p>and</p> $A_y = 0$ <p><i>Step 2.</i> Therefore, the couple (C_A) is</p> $C_A = C = 2,000 \text{ N} \cdot \text{m}$ <p>Note that as (C_A) is positive, this means it is counterclockwise (ccw).</p>

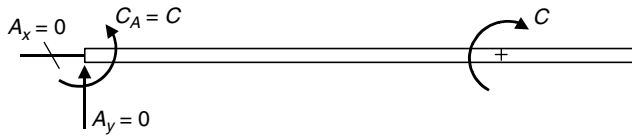

FIGURE 2.98 Free-body-diagram.

Shear Force and Bending Moment Distributions. For the cantilevered beam, with an applied couple (C) acting clockwise (cw) at a distance (a) from the support, shown in Fig. 2.99, which has the balanced free-body-diagram shown in Fig. 2.100, the shear force (V) distribution is shown in Fig. 2.101.

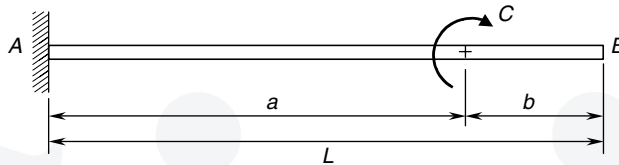

FIGURE 2.99 Concentrated force at intermediate point.



FIGURE 2.100 Free-body-diagram.

Note that the shear force (V) is zero from the left end of the beam to the right end of the beam. This is because the reactions (A_x and A_y) are zero, which is because the only load on the beam is an applied couple.

The bending moment (M) starts at the left end of the beam with a negative value of the couple ($-C$) and continues at this value for a distance (a). At this point where the applied couple acts, the bending moment becomes zero, and continues at this value to the right end of the beam.

The bending moment (M) distribution is shown in Fig. 2.102.

The maximum bending moment (M_{\max}) occurs in the region to the left of the applied couple (C) and given by Eq. (2.69).

$$M_{\max} = C \tag{2.69}$$

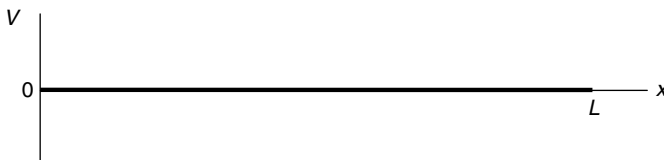

FIGURE 2.101 Shear force diagram.

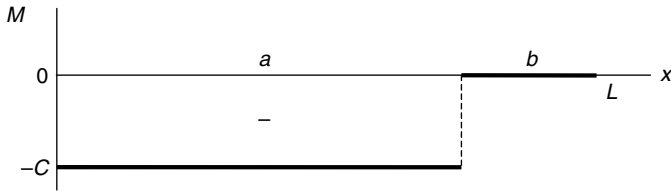

FIGURE 2.102 Bending moment diagram.

U.S. Customary	SI/Metric
<p>Example 2. Calculate the shear force (V) and bending moment (M) at a distance (x) for a cantilevered beam of length (L) with an applied couple (C) acting at a distance (a), where</p> $C = 1,500 \text{ ft} \cdot \text{lb}$ $L = 4 \text{ ft}, a = 3 \text{ ft}, b = 1 \text{ ft}$ $x = 2 \text{ ft}$ <p>solution</p> <p><i>Step 1.</i> As the distance (x) is less than the distance (a) to the couple (C), the shear force (V) from Fig. 2.101 is</p> $V = 0$ <p><i>Step 2.</i> Again, as the distance (x) is less than (a), the bending moment (M) is determined from Fig. 2.102 as</p> $M = -C = -1,500 \text{ ft} \cdot \text{lb}$ <p>Example 3. Calculate and locate the maximum shear force (V_{\max}) and the maximum bending moment (M_{\max}) for the beam of Examples 1 and 2, where</p> $C = 1,500 \text{ ft} \cdot \text{lb}$ $L = 4 \text{ ft}$ $a = 3 \text{ ft}, b = 1 \text{ ft}$ <p>solution</p> <p><i>Step 1.</i> As the shear force (V) is zero across the entire beam, there is no maximum shear force (V_{\max}).</p> <p><i>Step 2.</i> Calculate the maximum bending moment (M_{\max}) from Eq. (2.69) as</p> $M_{\max} = C = 1,500 \text{ ft} \cdot \text{lb}$ <p><i>Step 3.</i> Figure 2.102 shows that this maximum bending moment (M_{\max}) of 1,500 ft · lb occurs in the region to the left of the applied couple (C).</p>	<p>Example 2. Calculate the shear force (V) and bending moment (M) at a distance (x) for a cantilevered beam of length (L) with an applied couple (C) acting at a distance (a), where</p> $C = 2,000 \text{ N} \cdot \text{m}$ $L = 1.2 \text{ m}, a = 0.9 \text{ m}, b = 0.3 \text{ m}$ $x = 0.6 \text{ m}$ <p>solution</p> <p><i>Step 1.</i> As the distance (x) is less than the distance (a) to the couple (C), the shear force (V) from Fig. 2.101 is</p> $V = 0$ <p><i>Step 2.</i> Again, as the distance (x) is less than (a), the bending moment (M) is determined from Fig. 2.102 as</p> $M = -C = -2,000 \text{ N} \cdot \text{m}$ <p>Example 3. Calculate and locate the maximum shear force (V_{\max}) and the maximum bending moment (M_{\max}) for the beam of Examples 1 and 2, where</p> $C = 2,000 \text{ N} \cdot \text{m}$ $L = 1.2 \text{ m}$ $a = 0.9 \text{ m}, b = 0.3 \text{ m}$ <p>solution</p> <p><i>Step 1.</i> As the shear force (V) is zero across the entire beam, there is no maximum shear force (V_{\max}).</p> <p><i>Step 2.</i> Calculate the maximum bending moment (M_{\max}) from Eq. (2.69) as</p> $M_{\max} = C = 2,000 \text{ N} \cdot \text{m}$ <p><i>Step 3.</i> In Fig. 2.102 we see that this maximum bending moment (M_{\max}) of 2,000 N · m occurs in the region to the left of the applied couple (C).</p>

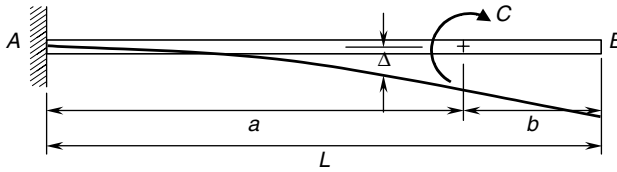

FIGURE 2.103 Beam deflection diagram.

Deflection. For this loading configuration, the deflection (Δ) along the beam is shown in Fig. 2.103, and given by Eq. (2.70a) for the values of the distance (x) from the left end of the beam to the location of the applied couple (C), at a distance (a), and by Eq. (2.70b) for the values of the distance (x) from the couple (C) to right end of the beam.

$$\Delta = \frac{Cx^2}{2EI} \quad 0 \leq x \leq a \quad (2.70a)$$

$$\Delta = \frac{Ca}{2EI}(2x - a) \quad a \leq x \leq L \quad (2.70b)$$

where Δ = deflection of beam

C = applied couple

x = distance from left end of beam

L = length of beam

a = distance to couple (C) from left end of beam

b = distance from couple (C) to right end of beam

E = modulus of elasticity of beam material

I = area moment of inertia of cross-sectional area about axis through centroid

The maximum deflection (Δ_{\max}) occurs at the free end, and is given by Eq. (2.67),

$$\Delta_{\max} = \frac{Ca}{2EI}(2L - a) \quad \text{at } x = L \quad (2.71)$$

and deflection (Δ_a) at the location of the couple (C) is given by Eq. (2.72),

$$\Delta_a = \frac{Ca^2}{2EI} \quad \text{at } x = a \quad (2.72)$$

U.S. Customary	SI/Metric
<p>Example 4. Calculate the deflection (Δ) at a distance (x) for a cantilevered beam of length (L) with an applied couple (C) acting at a distance (a), where</p> <p>$C = 1,500 \text{ ft} \cdot \text{lb}$ $L = 4 \text{ ft}$ $a = 3 \text{ ft}, b = 1 \text{ ft}$ $x = 2 \text{ ft}$ $E = 29 \times 10^6 \text{ lb/in}^2$ (steel) $I = 13 \text{ in}^4$</p>	<p>Example 4. Calculate the deflection (Δ) at a distance (x) for a cantilevered beam of length (L) with an applied couple (C) acting at a distance (a), where</p> <p>$C = 2,000 \text{ N} \cdot \text{m}$ $L = 1.2 \text{ m}$ $a = 0.9 \text{ m}, b = 0.3 \text{ m}$ $x = 0.6 \text{ m}$ $E = 207 \times 10^9 \text{ N/m}^2$ (steel) $I = 541 \text{ cm}^4$</p>

U.S. Customary	SI/Metric
<p>solution</p> <p><i>Step 1.</i> Calculate the stiffness (EI).</p> $EI = (29 \times 10^6 \text{ lb/in}^2) (13 \text{ in}^4)$ $= 3.77 \times 10^8 \text{ lb} \cdot \text{in}^2 \times \frac{1 \text{ ft}^2}{144 \text{ in}^2}$ $= 2.62 \times 10^6 \text{ lb} \cdot \text{ft}^2$ <p><i>Step 2.</i> As the distance (x) is less than the distance (a), determine the deflection (Δ) from Eq. (2.70a).</p> $\Delta = \frac{Cx^2}{2(EI)}$ $= \frac{(1,500 \text{ ft} \cdot \text{lb}) (2 \text{ ft})^2}{2 (2.62 \times 10^6 \text{ lb} \cdot \text{ft}^2)}$ $= \frac{(6,000 \text{ lb} \cdot \text{ft}^3)}{(5.24 \times 10^6 \text{ lb} \cdot \text{ft}^2)}$ $= 0.00115 \text{ ft} \times \frac{12 \text{ in}}{\text{ft}}$ $= 0.014 \text{ in} \downarrow$	<p>solution</p> <p><i>Step 1.</i> Calculate the stiffness (EI).</p> $EI = (207 \times 10^9 \text{ N/m}^2) (541 \text{ cm}^4)$ $\times \frac{1 \text{ m}^4}{(100 \text{ cm})^4}$ $= 1.12 \times 10^6 \text{ N} \cdot \text{m}^2$ <p><i>Step 2.</i> As the distance (x) is less than the distance (a), determine the deflection (Δ) from Eq. (2.70a).</p> $\Delta = \frac{Cx^2}{2(EI)}$ $= \frac{(2,000 \text{ N} \cdot \text{m}) (0.6 \text{ m})^2}{2 (1.12 \times 10^6 \text{ N} \cdot \text{m}^2)}$ $= \frac{(720 \text{ N} \cdot \text{m}^3)}{(2.24 \times 10^6 \text{ N} \cdot \text{m}^2)}$ $= 0.00032 \text{ m} \times \frac{100 \text{ cm}}{\text{m}}$ $= 0.032 \text{ cm} \downarrow$
<p>Example 5. Calculate the maximum deflection (Δ_{\max}) and its location for the beam configuration in Example 4, where</p> <p>$C = 1,500 \text{ ft} \cdot \text{lb}$ $L = 4 \text{ ft}$ $a = 3 \text{ ft}, b = 1 \text{ ft}$ $EI = 2.62 \times 10^6 \text{ lb} \cdot \text{ft}^2$</p>	<p>Example 5. Calculate the maximum deflection (Δ_{\max}) and its location for the beam configuration in Example 4, where</p> <p>$C = 2,000 \text{ N} \cdot \text{m}$ $L = 1.2 \text{ m}$ $a = 0.9 \text{ m}, b = 0.3 \text{ m}$ $EI = 1.12 \times 10^6 \text{ N} \cdot \text{m}^2$</p>
<p>solution</p> <p><i>Step 1.</i> Calculate the maximum deflection at the free end from Eq. (2.71).</p> $\Delta_{\max} = \frac{Ca}{2(EI)} (2L - a)$ $= \frac{(1,500 \text{ ft} \cdot \text{lb}) (3 \text{ ft})}{2 (2.62 \times 10^6 \text{ lb} \cdot \text{ft}^2)}$ $\times [2 (4 \text{ ft}) - 3 \text{ ft}]$ $= \frac{4.50 \times 10^3 \text{ lb} \cdot \text{ft}^2}{5.24 \times 10^6 \text{ lb} \cdot \text{ft}^2}$ $\times [(8 - 3) \text{ ft}]$ $= (8.59 \times 10^{-4}) \times (5 \text{ ft})$ $= 0.0043 \text{ ft} \times \frac{12 \text{ in}}{\text{ft}}$ $= 0.052 \text{ in} \downarrow$	<p>solution</p> <p><i>Step 1.</i> Calculate the maximum deflection at the free end from Eq. (2.71).</p> $\Delta_{\max} = \frac{Ca}{2(EI)} (2L - a)$ $= \frac{(2,000 \text{ N} \cdot \text{m}) (0.9 \text{ m})}{2 (1.12 \times 10^6 \text{ N} \cdot \text{m}^2)}$ $\times [2 (1.2 \text{ m}) - 0.9 \text{ m}]$ $= \frac{1.80 \times 10^3 \text{ N} \cdot \text{m}^2}{2.24 \times 10^6 \text{ N} \cdot \text{m}^2}$ $\times [(2.4 - 0.9) \text{ m}]$ $= (8.04 \times 10^{-4}) \times (1.5 \text{ m})$ $= 0.0012 \text{ m} \times \frac{100 \text{ cm}}{\text{m}}$ $= 0.12 \text{ cm} \downarrow$

U.S. Customary	SI/Metric
<p>Example 6. Calculate the deflection (Δ_a) where the couple (C) acts, where</p> <p>$C = 1,500 \text{ ft} \cdot \text{lb}$ $L = 4 \text{ ft}$ $a = 3 \text{ ft}, b = 1 \text{ ft}$ $EI = 2.62 \times 10^6 \text{ lb} \cdot \text{ft}^2$</p> <p>solution Calculate the deflection (Δ_a) where the couple (C) acts from Eq. (2.72).</p> $\Delta_a = \frac{Ca^2}{2(EI)}$ $= \frac{(1,500 \text{ ft} \cdot \text{lb})(3 \text{ ft})^2}{2(2.62 \times 10^6 \text{ lb} \cdot \text{ft}^2)}$ $= \frac{1.35 \times 10^4 \text{ lb} \cdot \text{ft}^3}{5.24 \times 10^6 \text{ lb} \cdot \text{ft}^2}$ $= 0.0026 \text{ ft} \times \frac{12 \text{ in}}{\text{ft}}$ $= 0.031 \text{ in} \downarrow$	<p>Example 6. Calculate the deflection (Δ_a) where the couple (C) acts, where</p> <p>$C = 2,000 \text{ N} \cdot \text{m}$ $L = 1.2 \text{ m}$ $a = 0.9 \text{ m}, b = 0.3 \text{ m}$ $EI = 1.12 \times 10^6 \text{ N} \cdot \text{m}^2$</p> <p>solution Calculate the deflection (Δ_a) where the couple (C) acts from Eq. (2.72).</p> $\Delta_{\max} = \frac{Ca^2}{2(EI)}$ $= \frac{(2,000 \text{ N} \cdot \text{m})(0.9 \text{ m})^2}{2(1.12 \times 10^6 \text{ N} \cdot \text{m}^2)}$ $= \frac{1.62 \times 10^3 \text{ N} \cdot \text{m}^3}{2.24 \times 10^6 \text{ N} \cdot \text{m}^2}$ $= 0.00072 \text{ m} \times \frac{100 \text{ cm}}{\text{m}}$ $= 0.072 \text{ cm} \downarrow$

2.3.4 Uniform Load

The cantilevered beam shown in Fig. 2.104 has a uniform distributed load (w) acting vertically downward across the entire length (L). The unit of this distributed load (w) is force per length. Therefore, the total force acting on the beam is the uniform load (w) times the length of the beam (L), or (wL), and for purposes of finding the reactions is considered located at the midpoint ($L/2$) of the beam.

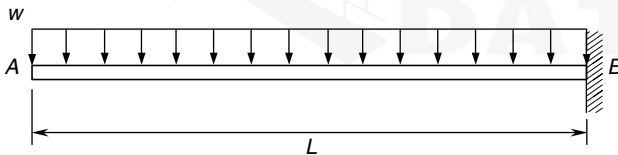

FIGURE 2.104 Uniform load.

Reactions. The reactions at the support are shown in Fig. 2.105—the balanced free-body diagram. Notice that the vertical reaction (B_y) is equal to the total load (wL), and because

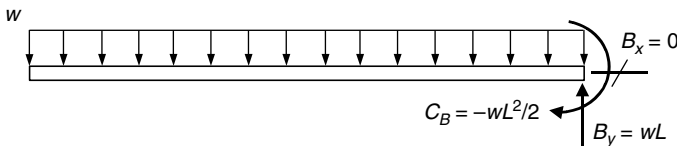

FIGURE 2.105 Free-body diagram.

the uniform load (w) is acting straight down, the horizontal reaction (B_x) is zero. The couple reaction (C_B) is in a negative direction, meaning clockwise (cw), and equal to a negative of the uniform load (wL) times the distance ($L/2$), or $(-wL^2/2)$.

U.S. Customary	SI/Metric
<p>Example 1. Determine the reactions for a cantilevered beam of length (L) with a uniform distributed load (w), where</p> <p>$w = 50 \text{ lb/ft}$ $L = 5 \text{ ft}$</p> <p>solution From Fig. 2.105 calculate the reactions (B_x, B_y, and C_B) at the right end of the beam.</p> <p><i>Step 1.</i> As the uniform load (w) is acting vertically downward,</p> $B_x = 0$ <p>and</p> $B_y = wL = (50 \text{ lb/ft})(5 \text{ ft}) = 250 \text{ lb}$ <p><i>Step 2.</i> The couple (C_B) is given by</p> $C_B = -\frac{wL^2}{2} = -\frac{(50 \text{ lb/ft})(5 \text{ ft})^2}{2} = -\frac{1,250 \text{ ft} \cdot \text{lb}}{2} = -625 \text{ ft} \cdot \text{lb}$ <p>Note that the minus sign on (C_B) means it is clockwise (cw).</p>	<p>Example 1. Determine the reactions for a cantilevered beam of length (L) with a uniform distributed load (w), where</p> <p>$w = 800 \text{ N/m}$ $L = 1.5 \text{ m}$</p> <p>solution From Fig. 2.105 calculate the reactions (B_x, B_y, and C_B) at the right end of the beam.</p> <p><i>Step 1.</i> As the uniform load (w) is acting vertically downward,</p> $B_x = 0$ <p>and</p> $B_y = wL = (800 \text{ N/m})(1.5 \text{ m}) = 1,200 \text{ N}$ <p><i>Step 2.</i> The couple (C_B) is given by</p> $C_B = -\frac{wL^2}{2} = -\frac{(800 \text{ N/m})(1.5 \text{ m})^2}{2} = -\frac{1,800 \text{ N} \cdot \text{m}}{2} = -900 \text{ N} \cdot \text{m}$ <p>Note that the minus sign means it is clockwise (cw).</p>

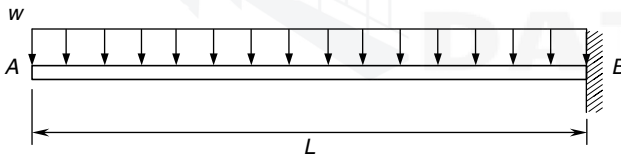

FIGURE 2.106 Uniform load.

Shear Force and Bending Moment Distributions. For the cantilevered beam with a uniform distributed load (w) acting across the entire length of the beam (L), shown in Fig. 2.106, which has the balanced free-body-diagram shown in Fig. 2.107, the shear force (V) distribution is shown in Fig. 2.108.

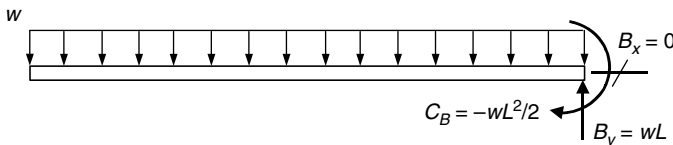

FIGURE 2.107 Free-body-diagram.

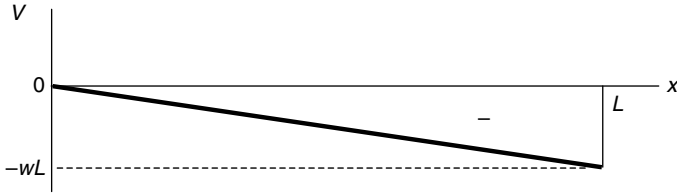

FIGURE 2.108 Shear force diagram.

Note that the shear force (V) is zero at the left end of the beam and decreases linearly to a negative value ($-wL$) at the right end of the beam. This shear force distribution is given by Eq. (2.73).

$$V = -wx \quad (2.73)$$

Therefore, the maximum shear force (V_{\max}) is given by Eq. (2.74).

$$V_{\max} = wL \quad (2.74)$$

The bending moment distribution is given by Eq. (2.75) for all values of the distance (x) equal to zero at the left end of the beam to a value (L) at the right end of the beam. (Always measure the distance (x) from the left end of any beam.)

$$M = -\frac{wx^2}{2} \quad 0 \leq x \leq L \quad (2.75)$$

The bending moment (M) distribution is shown in Fig. 2.109.

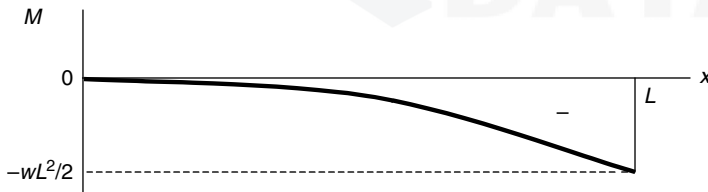

FIGURE 2.109 Bending moment diagram.

The bending moment (M) is zero at the left end of the beam and then decreases quadratically to a maximum negative value ($-wL^2/2$) at the right end. The maximum bending moment (M_{\max}) occurs at the right end of the beam as given by Eq. (2.76).

$$M_{\max} = \frac{wL^2}{2} \quad (2.76)$$

U.S. Customary	SI/Metric
<p>Example 2. Calculate the shear force (V) and bending moment (M) for a cantilevered beam of length (L) with a uniform distributed load (w) acting across its entire length, at a distance (x) from the left end of the beam, where</p> $w = 50 \text{ lb/ft}$ $L = 5 \text{ ft}$ $x = 4 \text{ ft}$ <p>solution</p> <p><i>Step 1.</i> Determine the shear force (V) from Eq. (2.73) as</p> $V = -wx = -(50 \text{ lb/ft})(4 \text{ ft})$ $= -200 \text{ lb}$ <p><i>Step 2.</i> Determine the bending moment (M) from Eq. (2.75).</p> $M = -\frac{wx^2}{2} = -\frac{(50 \text{ lb/ft})(4 \text{ ft})^2}{2}$ $= -\frac{800 \text{ ft} \cdot \text{lb}}{2}$ $= -400 \text{ ft} \cdot \text{lb}$ <p>Example 3. Calculate and locate the maximum shear force (V_{\max}) and the maximum bending moment (M_{\max}) for the beam of Examples 1 and 2, where</p> $w = 50 \text{ lb/ft}$ $L = 5 \text{ ft}$ <p>solution</p> <p><i>Step 1.</i> Calculate the maximum shear force (V_{\max}) from Eq. (2.74) as</p> $V_{\max} = wL = (50 \text{ lb/ft})(5 \text{ ft})$ $= 250 \text{ lb}$ <p><i>Step 2.</i> As shown in Fig. 2.108, this maximum shear force (V_{\max}) of 250 lb occurs at the right end of the beam.</p> <p><i>Step 3.</i> Calculate the maximum bending moment (M_{\max}) from Eq. (2.76) as</p> $M_{\max} = \frac{wL^2}{2} = \frac{(50 \text{ lb/ft})(5 \text{ ft})^2}{2}$ $= \frac{1,250 \text{ ft} \cdot \text{lb}}{2} = 625 \text{ ft} \cdot \text{lb}$	<p>Example 2. Calculate the shear force (V) and bending moment (M) for a cantilevered beam of length (L) with a uniform distributed load (w) acting across its entire length, at a distance (x) from the left end of the beam, where</p> $w = 800 \text{ N/m}$ $L = 1.5 \text{ m}$ $x = 1.2 \text{ m}$ <p>solution</p> <p><i>Step 1.</i> Determine the shear force (V) from Eq. (2.73) as</p> $V = -wx = -(800 \text{ N/m})(1.2 \text{ m})$ $= -960 \text{ N}$ <p><i>Step 2.</i> Determine the bending moment (M) from Eq. (2.75).</p> $M = -\frac{wx^2}{2} = -\frac{(800 \text{ N/m})(1.2 \text{ m})^2}{2}$ $= -\frac{1,152 \text{ N} \cdot \text{m}}{2}$ $= -576 \text{ N} \cdot \text{m}$ <p>Example 3. Calculate and locate the maximum shear force (V_{\max}) and the maximum bending moment (M_{\max}) for the beam of Examples 1 and 2, where</p> $w = 800 \text{ N/m}$ $L = 1.5 \text{ m}$ <p>solution</p> <p><i>Step 1.</i> Calculate the maximum shear force (V_{\max}) from Eq. (2.74) as</p> $V_{\max} = wL = (800 \text{ N/m})(1.5 \text{ m})$ $= 1,200 \text{ N}$ <p><i>Step 2.</i> As shown in Fig. 2.108, this maximum shear force (V_{\max}) of 1,200 N occurs at the right end of the beam.</p> <p><i>Step 3.</i> Calculate the maximum bending moment (M_{\max}) from Eq. (2.76) as</p> $M_{\max} = \frac{wL^2}{2} = \frac{(800 \text{ N/m})(1.5 \text{ m})^2}{2}$ $= \frac{1,800 \text{ N} \cdot \text{m}}{2} = 900 \text{ N} \cdot \text{m}$

U.S. Customary	SI/Metric
<i>Step 4.</i> As shown in Fig. 2.109, this maximum bending moment (M_{\max}) of 625 ft · lb occurs at the right end of the beam, meaning at the wall support.	<i>Step 4.</i> As shown in Fig. 2.109, this maximum bending moment (M_{\max}) of 900 N · m occurs at the right end of the beam, meaning at the wall support.

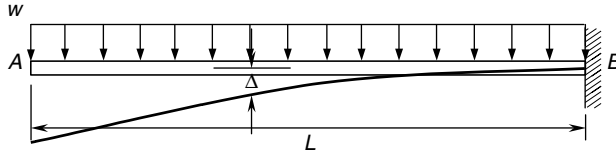

FIGURE 2.110 Beam deflection diagram.

Deflection. For this loading configuration, the deflection (Δ) along the beam is shown in Fig. 2.110, and given by Eq. (2.77) for values of the distance (x) from the left end of the beam, as

$$\Delta = \frac{w}{24EI}(x^4 - 4L^3x + 3L^4) \quad 0 \leq x \leq L \quad (2.77)$$

where Δ = deflection of beam

w = uniform distributed load

x = distance from left end of beam

L = length of beam

E = modulus of elasticity of beam material

I = area moment of inertia of cross-sectional area about axis through centroid

The maximum deflection (Δ_{\max}) occurs at the free end, and is given by Eq. (2.78),

$$\Delta_{\max} = \frac{wL^4}{8EI} \quad \text{at } x = 0 \quad (2.78)$$

U.S. Customary	SI/Metric
<p>Example 4. Calculate the deflection (Δ) for a cantilevered beam with a uniform distributed load (w) acting across its entire length (L), at a distance (x) from the left end of the beam, where</p> <p>$w = 50$ lb/ft $L = 5$ ft $x = 4$ ft $E = 10 \times 10^6$ lb/in² (aluminum) $I = 36$ in⁴</p> <p>solution</p> <p><i>Step 1.</i> Calculate the stiffness (EI).</p> $EI = (10 \times 10^6 \text{ lb/in}^2)(36 \text{ in}^4)$ $= 3.60 \times 10^8 \text{ lb} \cdot \text{in}^2 \times \frac{1 \text{ ft}^2}{144 \text{ in}^2}$ $= 2.5 \times 10^6 \text{ lb} \cdot \text{ft}^2$	<p>Example 4. Calculate the deflection (Δ) for a cantilevered beam with a uniform distributed load (w) acting across its entire length (L), at a distance (x) from the left end of the beam, where</p> <p>$w = 800$ N/m $L = 1.5$ m $x = 1.2$ m $E = 100 \times 10^9$ N/m² (aluminum) $I = 1,500$ cm⁴</p> <p>solution</p> <p><i>Step 1.</i> Calculate the stiffness (EI).</p> $EI = (100 \times 10^9 \text{ N/m}^2)(1,500 \text{ cm}^4)$ $\times \frac{1 \text{ m}^4}{(100 \text{ cm})^4}$ $= 1.5 \times 10^6 \text{ N} \cdot \text{m}^2$

U.S. Customary	SI/Metric
<p><i>Step 2.</i> Determine the deflection (Δ) from Eq. (2.77).</p> $\Delta = \frac{w}{24(EI)}(x^4 - 4L^3x + 3L^4)$ $= \frac{(50 \text{ lb/ft})}{24(2.5 \times 10^6 \text{ lb} \cdot \text{ft}^2)} \times [(4 \text{ ft})^4 - 4(5 \text{ ft})^3(4 \text{ ft}) + 3(5 \text{ ft})^4]$ $\Delta = \frac{(50 \text{ lb/ft})}{(6 \times 10^7 \text{ lb} \cdot \text{ft}^2)} \times [(256 - 2,000 + 1,875) \text{ ft}^4]$ $= \left(8.33 \times 10^{-7} \frac{1}{\text{ft}^3}\right) \times (131 \text{ ft}^4)$ $= 0.00011 \text{ ft} \times \frac{12 \text{ in}}{\text{ft}}$ $= 0.0013 \text{ in} \downarrow$ <p>Example 5. Calculate the maximum deflection (Δ_{\max}) and its location for the beam configuration in Example 4, where</p> <p>$w = 50 \text{ lb/ft}$ $L = 5 \text{ ft}$ $EI = 2.5 \times 10^6 \text{ lb} \cdot \text{ft}^2$</p> <p>solution</p> <p><i>Step 1.</i> Calculate the maximum deflection at the free end from Eq. (2.78).</p> $\Delta_{\max} = \frac{wL^4}{8(EI)}$ $= \frac{(50 \text{ lb/ft})(5 \text{ ft})^4}{8(2.5 \times 10^6 \text{ lb} \cdot \text{ft}^2)}$ $= \frac{31,250 \text{ lb} \cdot \text{ft}^3}{2 \times 10^7 \text{ lb} \cdot \text{ft}^2}$ $= 0.0016 \text{ ft} \times \frac{12 \text{ in}}{\text{ft}}$ $= 0.019 \text{ in} \downarrow$	<p><i>Step 2.</i> Determine the deflection (Δ) from Eq. (2.77).</p> $\Delta = \frac{w}{24(EI)}(x^4 - 4L^3x + 3L^4)$ $= \frac{(800 \text{ N/m})}{24(1.5 \times 10^6 \text{ N} \cdot \text{m}^2)} [(1.2 \text{ m})^4 - 4(1.5 \text{ m})^3(1.2 \text{ m}) + 3(1.5 \text{ m})^4]$ $\Delta = \frac{(800 \text{ N/m})}{(3.6 \times 10^7 \text{ N} \cdot \text{m}^2)} \times [(2.0736 - 16.2 + 15.1875) \text{ m}^4]$ $= \left(2.22 \times 10^{-5} \frac{1}{\text{m}^3}\right) \times (1.0611 \text{ m}^4)$ $= 0.0000235 \text{ m} \times \frac{100 \text{ cm}}{\text{m}}$ $= 0.0024 \text{ cm} \downarrow$ <p>Example 5. Calculate the maximum deflection (Δ_{\max}) and its location for the beam configuration in Example 4, where</p> <p>$w = 800 \text{ N/m}$ $L = 1.5 \text{ m}$ $EI = 1.5 \times 10^6 \text{ N} \cdot \text{m}^2$</p> <p>solution</p> <p><i>Step 1.</i> Calculate the maximum deflection at the free end from Eq. (2.78).</p> $\Delta_{\max} = \frac{wL^4}{8(EI)}$ $= \frac{(800 \text{ N/m})(1.5 \text{ m})^4}{8(1.5 \times 10^6 \text{ N} \cdot \text{m}^2)}$ $= \frac{4,050 \text{ N} \cdot \text{m}^3}{1.2 \times 10^7 \text{ N} \cdot \text{m}^2}$ $= 0.00034 \text{ m} \times \frac{100 \text{ cm}}{\text{m}}$ $= 0.034 \text{ cm} \downarrow$

2.3.5 Triangular Load

The cantilevered beam shown in Fig. 2.111 has a triangular distributed load (w) acting vertically downward across the entire length (L). The unit of this distributed load (w) is force per length. As the distribution is triangular, the total force acting on the beam is one half ($1/2$) times the uniform load (w) times the length of the beam (L), or ($wL/2$). For finding the reactions, this total load is considered to be located at a point one-third ($1/3$) the distance from the right end of the beam, or ($L/3$).

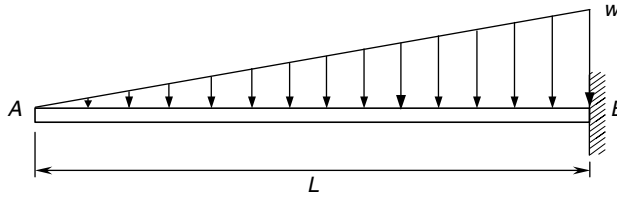

FIGURE 2.111 Triangular load.

Reactions. The reactions at the support are shown in Fig. 2.112—the balanced free-body diagram. Notice that the vertical reaction (B_y) is equal to the total load ($wL/2$), and as the triangular load (w) is acting straight down, the horizontal reaction (B_x) is zero. The couple reaction (C_B) is in a negative direction, meaning clockwise (cw), and equal to a negative of the total load ($wL/2$) times the distance ($L/3$), or $(-wL^2/6)$.

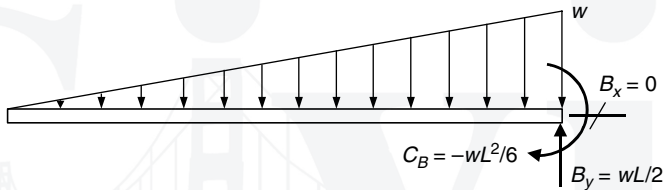

FIGURE 2.112 Free-body diagram.

U.S. Customary	SI/Metric
<p>Example 1. Determine the reactions for a cantilevered beam of length (L) with a triangular load (w), where</p> <p>$w = 300 \text{ lb/ft}$ $L = 6 \text{ ft}$</p> <p>solution From Fig. 2.112 calculate the reactions (B_x, B_y, and C_B) at the right end of the beam.</p> <p><i>Step 1.</i> As the triangular load (w) is acting vertically downward,</p> $B_x = 0$ <p>and</p> $B_y = \frac{wL}{2} = \frac{(300 \text{ lb/ft})(6 \text{ ft})}{2}$ $= \frac{1,800 \text{ lb}}{2} = 900 \text{ lb}$	<p>Example 1. Determine the reactions for a cantilevered beam of length (L) with a triangular load (w), where</p> <p>$w = 4,500 \text{ N/m}$ $L = 1.8 \text{ m}$</p> <p>solution From Fig. 2.112, calculate the reactions (B_x, B_y, and C_B) at the right end of the beam.</p> <p><i>Step 1.</i> As the triangular load (w) is acting vertically downward,</p> $B_x = 0$ <p>and</p> $B_y = \frac{wL}{2} = \frac{(4,500 \text{ N/m})(1.8 \text{ m})}{2}$ $= \frac{8,100 \text{ N}}{2} = 4,050 \text{ N}$

U.S. Customary	SI/Metric
<p>Step 2. The couple (C_B) is given by</p> $C_B = -\frac{wL^2}{6} = -\frac{(300 \text{ lb/ft})(6 \text{ ft})^2}{6}$ $= -\frac{10,800 \text{ ft} \cdot \text{lb}}{6} = -1,800 \text{ ft} \cdot \text{lb}$ <p>Note that the minus sign on (C_B) means it is clockwise (cw).</p>	<p>Step 2. The couple (C_B) is given by</p> $C_B = -\frac{wL^2}{6} = -\frac{(4,500 \text{ N/m})(1.8 \text{ m})^2}{6}$ $= -\frac{14,580 \text{ N} \cdot \text{m}}{6} = -2,430 \text{ N} \cdot \text{m}$ <p>Note that the minus sign on (C_B) means it is clockwise (cw).</p>

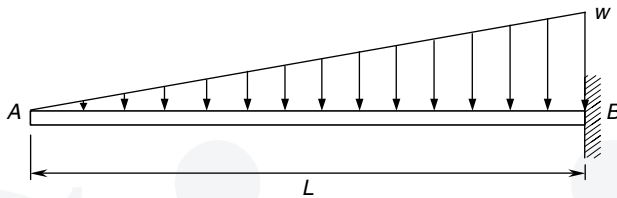

FIGURE 2.113 Uniform load.

Shear Force and Bending Moment Distributions. For the cantilevered beam with a triangular distributed load (w) acting across the entire length of the beam (L), shown in Fig. 2.113, which has the balanced free-body diagram shown in Fig. 2.114, the shear force (V) distribution is shown in Fig. 2.115.

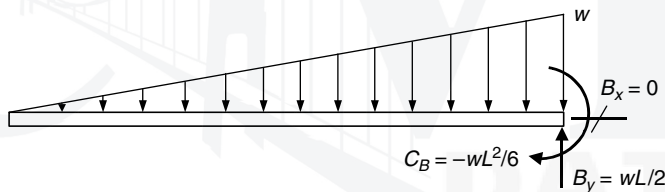

FIGURE 2.114 Free-body diagram.

Note that the shear force (V) is zero at the left end of the beam and decreases quadratically to a negative value ($-wL/2$) at the right end of the beam. This shear force distribution is given by Eq. (2.79).

$$V = -\frac{wx^2}{2L} \tag{2.79}$$

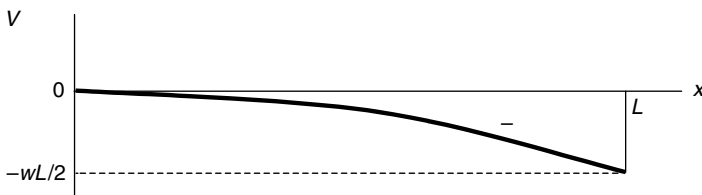

FIGURE 2.115 Shear force diagram.

Therefore, the maximum shear force (V_{\max}) is given by Eq. (2.80).

$$V_{\max} = \frac{wL}{2} \quad (2.80)$$

The bending moment distribution is given by Eq. (2.81) for values of the distance (x) equal to zero at the left end of the beam to a value (L) at the right end of the beam.

$$M = -\frac{wx^3}{6L} \quad 0 \leq x \leq L \quad (2.81)$$

The bending moment (M) distribution is shown in Fig. 2.116.

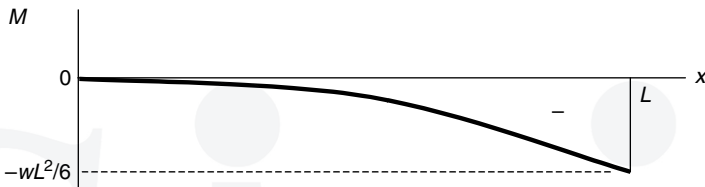

FIGURE 2.116 Bending moment diagram.

The bending moment (M) is zero at the left end of the beam, then decreases cubically to a maximum negative value ($-wL^2/6$) at the right end. The maximum bending moment (M_{\max}) occurs at the right end of the beam, given by Eq. (2.82).

$$M_{\max} = \frac{wL^2}{6} \quad (2.82)$$

U.S. Customary	SI/Metric
<p>Example 2. Calculate the shear force (V) and bending moment (M) for a cantilevered beam of length (L) with a triangular distributed load (w) acting across its entire length, at a distance (x) from the left end of the beam, where</p> <p>$w = 300 \text{ lb/ft}$ $L = 6 \text{ ft}$ $x = 2 \text{ ft}$</p> <p>solution <i>Step 1.</i> Determine the shear force (V) from Eq. (2.79) as</p> $V = -\frac{wx^2}{2L} = -\frac{(300 \text{ lb/ft})(2 \text{ ft})^2}{2(6 \text{ ft})}$ $= -\frac{1,200 \text{ ft} \cdot \text{lb}}{12 \text{ ft}} = -100 \text{ lb}$	<p>Example 2. Calculate the shear force (V) and bending moment (M) for a cantilevered beam of length (L) with a triangular distributed load (w) acting across its entire length, at a distance (x) from the left end of the beam, where</p> <p>$w = 4,500 \text{ N/m}$ $L = 1.8 \text{ m}$ $x = 0.6 \text{ m}$</p> <p>solution <i>Step 1.</i> Determine the shear force (V) from Eq. (2.79) as</p> $V = -\frac{wx^2}{2L} = -\frac{(4,500 \text{ N/m})(0.6 \text{ m})^2}{2(1.8 \text{ m})}$ $= -\frac{1,620 \text{ N} \cdot \text{m}}{3.6 \text{ m}} = -450 \text{ N}$

U.S. Customary	SI/Metric
<p><i>Step 2.</i> Determine the bending moment (M) from Eq. (2.81).</p> $M = -\frac{wx^3}{6L} = -\frac{(300 \text{ lb/ft})(2 \text{ ft})^3}{6(6 \text{ ft})}$ $= -\frac{2,400 \text{ ft} \cdot \text{lb}}{36 \text{ ft}}$ $= -67 \text{ ft} \cdot \text{lb}$ <p>Example 3. Calculate and locate the maximum shear force (V_{\max}) and the maximum bending moment (M_{\max}) for the beam of Examples 1 and 2, where</p> $w = 300 \text{ lb/ft}$ $L = 6 \text{ ft}$ <p>solution</p> <p><i>Step 1.</i> Calculate the maximum shear force (V_{\max}) from Eq. (2.80) as</p> $V_{\max} = \frac{wL}{2} = \frac{(300 \text{ lb/ft})(6 \text{ ft})}{2}$ $= \frac{1,800 \text{ lb}}{2} = 900 \text{ lb}$ <p><i>Step 2.</i> Figure 2.115 shows that this maximum shear force (V_{\max}) of 900 lb occurs at the right end of the beam.</p> <p><i>Step 3.</i> Calculate the maximum bending moment (M_{\max}) from Eq. (2.82) as</p> $M_{\max} = \frac{wL^2}{6} = \frac{(300 \text{ lb/ft})(6 \text{ ft})^2}{6}$ $= \frac{10,800 \text{ ft} \cdot \text{lb}}{6}$ $= 1,800 \text{ ft} \cdot \text{lb}$ <p><i>Step 4.</i> Figure 2.116 shows that this maximum bending moment (M_{\max}) of 1,800 ft · lb occurs at the right end of the beam, meaning at the wall support.</p>	<p><i>Step 2.</i> Determine the bending moment (M) from Eq. (2.81).</p> $M = -\frac{wx^3}{6L} = -\frac{(4,500 \text{ N/m})(0.6 \text{ m})^3}{6(1.8 \text{ m})}$ $= -\frac{972 \text{ N} \cdot \text{m}}{10.8 \text{ m}}$ $= -90 \text{ N} \cdot \text{m}$ <p>Example 3. Calculate and locate the maximum shear force (V_{\max}) and the maximum bending moment (M_{\max}) for the beam of Examples 1 and 2, where</p> $w = 4,500 \text{ N/m}$ $L = 1.8 \text{ m}$ <p>solution</p> <p><i>Step 1.</i> Calculate the maximum shear force (V_{\max}) from Eq. (2.80) as</p> $V_{\max} = \frac{wL}{2} = \frac{(4,500 \text{ N/m})(1.8 \text{ m})}{2}$ $= \frac{8,100 \text{ N}}{2} = 4,050 \text{ N}$ <p><i>Step 2.</i> Figure 2.115 shows that this maximum shear force (V_{\max}) of 4,050 N occurs at the right end of the beam.</p> <p><i>Step 3.</i> Calculate the maximum bending moment (M_{\max}) from Eq. (2.82) as</p> $M_{\max} = \frac{wL^2}{6} = \frac{(4,500 \text{ N/m})(1.8 \text{ m})^2}{6}$ $= \frac{14,580 \text{ N} \cdot \text{m}}{6}$ $= 2,430 \text{ N} \cdot \text{m}$ <p><i>Step 4.</i> Figure 2.116 shows that this maximum bending moment (M_{\max}) of 2,430 N · m occurs at the right end of the beam, meaning at the wall support.</p>

Deflection. For this loading configuration, the deflection (Δ) along the beam is shown in Fig. 2.117, and given by Eq. (2.83) for all values of the distance (x) from the left end of the beam, as

$$\Delta = \frac{w}{120 EIL} (x^5 - 5L^4x + 4L^5) \quad 0 \leq x \leq L \quad (2.83)$$

where Δ = deflection of beam
 w = triangular distributed load
 x = distance from left end of beam

L = length of beam

E = modulus of elasticity of beam material

I = area moment of inertia of cross-sectional area about axis through centroid

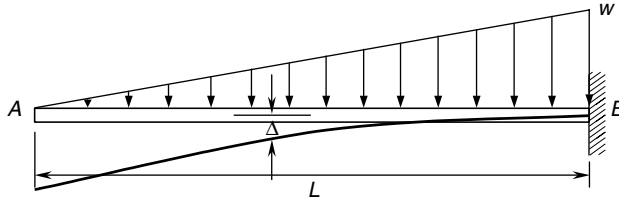

FIGURE 2.117 Beam deflection diagram.

The maximum deflection (Δ_{\max}) occurs at the free end, and is given by Eq. (2.84),

$$\Delta_{\max} = \frac{wL^4}{30EI} \quad \text{at } x = 0 \quad (2.84)$$

U.S. Customary	SI/Metric
<p>Example 4. Calculate the deflection (Δ) for a cantilevered beam with a triangular distributed load (w) acting across its entire length (L), at a distance (x) from the left end of the beam, where</p> <p>$w = 300 \text{ lb/ft}$ $L = 6 \text{ ft}$ $x = 2 \text{ ft}$ $E = 29 \times 10^6 \text{ lb/in}^2$ (steel) $I = 16 \text{ in}^4$</p> <p>solution</p> <p><i>Step 1.</i> Calculate the stiffness (EI).</p> $EI = (29 \times 10^6 \text{ lb/in}^2)(16 \text{ in}^4)$ $= 4.64 \times 10^8 \text{ lb} \cdot \text{in}^2 \times \frac{1 \text{ ft}^2}{144 \text{ in}^2}$ $= 3.22 \times 10^6 \text{ lb} \cdot \text{ft}^2$ <p><i>Step 2.</i> Determine the deflection (Δ) from Eq. (2.83).</p> $\Delta = \frac{w}{120(EI)L} (x^5 - 5L^4x + 4L^5)$ $= \frac{(300 \text{ lb/ft})}{120(3.22 \times 10^6 \text{ lb} \cdot \text{ft}^2)(6 \text{ ft})} \times [(2 \text{ ft})^5 - 5(6 \text{ ft})^4(2 \text{ ft}) + 4(6 \text{ ft})^5]$ $= \frac{(300 \text{ lb/ft})}{(2.32 \times 10^9 \text{ lb} \cdot \text{ft}^3)} \times [(32 - 12,960 + 31,104) \text{ ft}^5]$	<p>Example 4. Calculate the deflection (Δ) for a cantilevered beam with a triangular distributed load (w) acting across its entire length (L), at a distance (x) from the left end of the beam, where</p> <p>$w = 4,500 \text{ N/m}$ $L = 1.8 \text{ m}$ $x = 0.6 \text{ m}$ $E = 207 \times 10^9 \text{ N/m}^2$ (steel) $I = 666 \text{ cm}^4$</p> <p>solution</p> <p><i>Step 1.</i> Calculate the stiffness (EI).</p> $EI = (207 \times 10^9 \text{ N/m}^2)(666 \text{ cm}^4)$ $\times \frac{1 \text{ m}^4}{(100 \text{ cm})^4}$ $= 1.38 \times 10^6 \text{ N} \cdot \text{m}^2$ <p><i>Step 2.</i> Determine the deflection (Δ) from Eq. (2.83).</p> $\Delta = \frac{w}{120(EI)L} (x^5 - 5L^4x + 4L^5)$ $= \frac{(4,500 \text{ N/m})}{120(1.38 \times 10^6 \text{ N} \cdot \text{m}^2)(1.8 \text{ m})} \times [(0.6 \text{ m})^5 - 5(1.8 \text{ m})^4(0.6 \text{ m}) + 4(1.8 \text{ m})^5]$ $= \frac{(4,500 \text{ N/m})}{(2.98 \times 10^8 \text{ N} \cdot \text{m}^3)} \times [(0.078 - 31.493 + 75.583) \text{ m}^5]$

U.S. Customary	SI/Metric
$= \left(1.29 \times 10^{-7} \frac{1}{\text{ft}^4} \right) \times (18,176 \text{ ft}^5)$ $= 0.00235 \text{ ft} \times \frac{12 \text{ in}}{\text{ft}}$ $= 0.028 \text{ in} \downarrow$ <p>Example 5. Calculate the maximum deflection (Δ_{\max}) and its location for the beam configuration in Example 4, where</p> $w = 300 \text{ lb/ft}$ $L = 6 \text{ ft}$ $EI = 3.22 \times 10^6 \text{ lb} \cdot \text{ft}^2$ <p>solution</p> <p><i>Step 1.</i> Calculate the maximum deflection at the free end from Eq. (2.84).</p> $\Delta_{\max} = \frac{wL^4}{30(EI)}$ $= \frac{(300 \text{ lb/ft})(6 \text{ ft})^4}{30(3.22 \times 10^6 \text{ lb} \cdot \text{ft}^2)}$ $= \frac{388,800 \text{ lb} \cdot \text{ft}^3}{9.66 \times 10^7 \text{ lb} \cdot \text{ft}^2}$ $= 0.0040 \text{ ft} \times \frac{12 \text{ in}}{\text{ft}}$ $= 0.048 \text{ in} \downarrow$	$= \left(1.51 \times 10^{-5} \frac{1}{\text{m}^4} \right) \times (44.168 \text{ m}^5)$ $= 0.00067 \text{ m} \times \frac{100 \text{ cm}}{\text{m}}$ $= 0.067 \text{ cm} \downarrow$ <p>Example 5. Calculate the maximum deflection (Δ_{\max}) and its location for the beam configuration in Example 4, where</p> $w = 4,500 \text{ N/m}$ $L = 1.8 \text{ m}$ $EI = 1.38 \times 10^6 \text{ N} \cdot \text{m}^2$ <p>solution</p> <p><i>Step 1.</i> Calculate the maximum deflection at the free end from Eq. (2.84).</p> $\Delta_{\max} = \frac{wL^4}{30(EI)}$ $= \frac{(4,500 \text{ N/m})(1.8 \text{ m})^4}{30(1.38 \times 10^6 \text{ N} \cdot \text{m}^2)}$ $= \frac{47,239 \text{ N} \cdot \text{m}^3}{4.14 \times 10^7 \text{ N} \cdot \text{m}^2}$ $= 0.00114 \text{ m} \times \frac{100 \text{ cm}}{\text{m}}$ $= 0.114 \text{ cm} \downarrow$

CHAPTER 3

ADVANCED LOADINGS

3.1 INTRODUCTION

In this chapter three advanced topics are presented: pressure loading, contact loading, and rotational loading. All three are very important to the machine designer.

Pressure Loading. Pressure loading occurs when a pressure above atmospheric which is typically internal, acts on a machine element such as a thin-walled sphere or cylinder, a thick-walled cylinder, or the pressure caused by press or shrink fits. External pressure on thin-walled vessels causes buckling, a very advanced topic requiring application of the theory of elasticity. Therefore, buckling of thin shells is not included here.

Contact Loading. Contact loading occurs when two machine elements are in contact owing to a compressive loading, particularly over a very small contact area. The stresses over the contact area between two spheres, as well as between two cylinders, will be presented. Contact stresses between either a sphere or cylinder rolling on a flat surface will also be presented.

Rotational Loading. Rotational loading occurs when a machine element, such as a grinding wheel or compressor blade, is rotating at a relatively high speed. The tangential and radial stresses produced are similar to those found for thick-walled cylinders; however, the source of the loading is caused by inertial forces that can be related to the rotational speed, material density, and Poisson's ratio of the machine element.

3.2 PRESSURE LOADINGS

In the case of a pressure loading on a thin-walled vessel, either spherical or cylindrical, the circumferential stresses produced do not vary radially over the thin cross section of the vessel. However, for thick-walled cylinders, not only does the circumferential stress vary in the radial direction, there is an additional stress in the radial direction that is not constant over the cross section. The equations for thick-walled cylinders will be applied to the problem of press or shrink fits, where the interface between the two machine elements is of primary interest and the deformation of the two elements will be presented. As it turns out, only normal stresses are produced by pressure loadings, meaning there are no shear stresses developed.

3.2.1 Thin-Walled Vessels

Thin-walled vessels are typically either spherical or cylindrical. Other geometries are possible, but their complexity precludes their inclusion in this book. Pressure vessels can be considered *thin* if the diameter is greater than ten times the thickness of the wall.

Spheres. For the thin-walled spherical pressure vessel shown in Fig. 3.1, the normal stress (σ_{sph}) in the wall of the sphere is given by Eq. (3.1),

$$\sigma_{\text{sph}} = \frac{p_i r_m}{2t} \quad (3.1)$$

where p_i = internal gage pressure (meaning above atmospheric pressure)
 r_m = mean radius (can be assumed to be the inside radius of the sphere)
 t = wall thickness

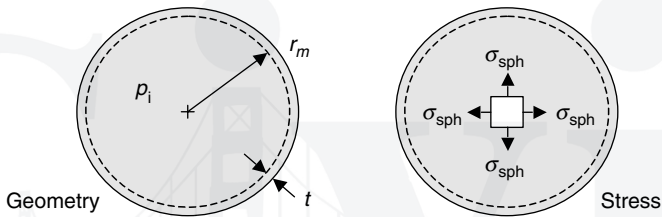

FIGURE 3.1 Spherical pressure vessel.

Caution. External pressure on any thin-walled vessel causes buckling of the vessel wall long before excessive stress is reached. The study of the buckling of thin-walled vessels is very complex, and is beyond the scope of this book.

U.S. Customary	SI/Metric
<p>Example 1. Determine the normal stress (σ_{sph}) in a thin-walled spherical vessel, where</p> <p>$p_i = 200$ psi $r_m = 3$ ft = 36 in $t = 0.25$ in</p> <p>solution <i>Step 1.</i> Using Eq. (3.1), calculate the normal stress (σ_{sph}) as</p> $\begin{aligned} \sigma_{\text{sph}} &= \frac{p_i r_m}{2t} = \frac{(200 \text{ lb/in}^2)(36 \text{ in})}{2(0.25 \text{ in})} \\ &= \frac{7,200 \text{ lb/in}}{0.5 \text{ in}} \\ &= 14,400 \text{ lb/in}^2 = 14.4 \text{ kpsi} \end{aligned}$	<p>Example 1. Determine the normal stress (σ_{sph}) in a thin-walled spherical vessel, where</p> <p>$p_i = 1.4$ MPa = 1,400,000 N/m² $r_m = 1$ m $t = 0.6$ cm = 0.006 m</p> <p>solution <i>Step 1.</i> Using Eq. (3.1), calculate the normal stress (σ_{sph}) as</p> $\begin{aligned} \sigma_{\text{sph}} &= \frac{p_i r_m}{2t} = \frac{(1,400,000 \text{ N/m}^2)(1 \text{ m})}{2(0.006 \text{ m})} \\ &= \frac{1,400,000 \text{ N/m}}{0.012 \text{ m}} \\ &= 1.167 \times 10^8 \text{ N/m}^2 = 116.7 \text{ MPa} \end{aligned}$

U.S. Customary	SI/Metric
<p>Example 2. Determine the maximum internal gage pressure (p_i) for a spherical steel tank where the maximum normal stress (σ_{sph}) is 18,000 psi, and where</p> $r_m = 6 \text{ ft} = 72 \text{ in}$ $t = 0.5 \text{ in}$ <p>solution</p> <p><i>Step 1.</i> Solve for the internal pressure (p_i) using Eq. (3.1).</p> $\sigma_{\text{sph}} = \frac{p_i r_m}{2t} \rightarrow p_i = \frac{2t\sigma_{\text{sph}}}{r_m}$ <p><i>Step 2.</i> Substitute for the thickness (t), the maximum normal stress (σ_{sph}), and the mean radius (r_m) to give</p> $p_i = \frac{2t\sigma_{\text{sph}}}{r_m}$ $= \frac{2(0.5 \text{ in})(18,000 \text{ lb/in}^2)}{72 \text{ in}}$ $= \frac{18,000 \text{ lb/in}}{72 \text{ in}}$ $= 250 \text{ lb/in}^2 = 250 \text{ psi}$	<p>Example 2. Determine the maximum internal gage pressure (p_i) for a spherical steel tank where the maximum normal stress (σ_{sph}) is 126 MPa, and where</p> $r_m = 2 \text{ m}$ $t = 1.3 \text{ cm} = 0.013 \text{ m}$ <p>solution</p> <p><i>Step 1.</i> Solve for the internal pressure (p_i) using Eq. (3.1).</p> $\sigma_{\text{sph}} = \frac{p_i r_m}{2t} \rightarrow p_i = \frac{2t\sigma_{\text{sph}}}{r_m}$ <p><i>Step 2.</i> Substitute for the thickness (t), the maximum normal stress (σ_{sph}), and the mean radius (r_m) to give</p> $p_i = \frac{2t\sigma_{\text{sph}}}{r_m}$ $= \frac{2(0.013 \text{ m})(126,000,000 \text{ N/m}^2)}{2 \text{ m}}$ $= \frac{3,276,000 \text{ N/m}}{2 \text{ m}}$ $= 1,638,000 \text{ N/m}^2 = 1.64 \text{ MPa}$

Cylinders. For the thin-walled cylindrical pressure vessel shown in Fig. 3.2, the normal axial stress (σ_{axial}) in the wall of the cylinder is given by Eq. (3.2),

$$\sigma_{\text{axial}} = \frac{p_i r_m}{2t} \tag{3.2}$$

the normal hoop stress (σ_{hoop}) in the wall of the cylinder is given by Eq. (3.3),

$$\sigma_{\text{hoop}} = \frac{p_i r_m}{t} \tag{3.3}$$

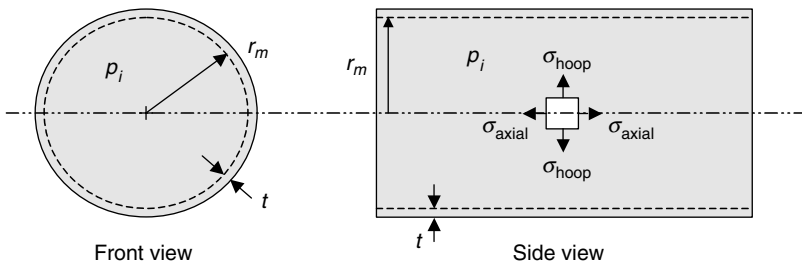

FIGURE 3.2 Cylindrical pressure vessel.

where p_i = internal gage pressure (meaning above atmospheric pressure)
 r_m = mean radius (can be assumed to be the inside radius of cylinder)
 t = wall thickness

Notice that the hoop stress (σ_{hoop}) is twice the axial stress (σ_{axial}). This is why metal stress rings, or hoops, are seen in cylindrical pressure vessels constructed of low-strength materials such as fiberglass. Fiberglass is chosen because of the corrosive effects of certain liquids and gases, and the metal hoops provide the strength not present in the fiberglass. Also notice that the axial stress (σ_{axial}) in a thin-walled cylinder is the same as the stress (σ_{sph}) in a thin-walled sphere. This means that there will be no discontinuity at the welded seams of a cylindrical pressure vessel with spherical end caps.

U.S. Customary	SI/Metric
<p>Example 3. Calculate the axial stress (σ_{axial}) and hoop stress (σ_{hoop}) for a thin-walled cylindrical pressure vessel, where</p> $p_i = 300 \text{ psi}$ $r_m = 2.5 \text{ ft} = 30 \text{ in}$ $t = 0.375 \text{ in}$ <p>solution <i>Step 1.</i> Using Eq. (3.2), calculate the axial stress (σ_{axial}) as</p> $\begin{aligned} \sigma_{\text{axial}} &= \frac{p_i r_m}{2t} = \frac{(300 \text{ lb/in}^2)(30 \text{ in})}{2(0.375 \text{ in})} \\ &= \frac{9,000 \text{ lb/in}}{0.75 \text{ in}} \\ &= 12,000 \text{ lb/in}^2 = 12 \text{ kpsi} \end{aligned}$ <p><i>Step 2.</i> Using Eq. (3.3), calculate the hoop stress (σ_{hoop}) as</p> $\begin{aligned} \sigma_{\text{hoop}} &= \frac{p_i r_m}{t} = \frac{(300 \text{ lb/in}^2)(30 \text{ in})}{(0.375 \text{ in})} \\ &= \frac{9,000 \text{ lb/in}}{0.375} \\ &= 24,000 \text{ lb/in}^2 = 24 \text{ kpsi} \end{aligned}$	<p>Example 3. Calculate the axial stress (σ_{axial}) and hoop stress (σ_{hoop}) for a thin-walled cylindrical pressure vessel, where</p> $p_i = 2.1 \text{ MPa} = 2,100,000 \text{ N/m}^2$ $r_m = 0.8 \text{ m}$ $t = 1 \text{ cm} = 0.01 \text{ m}$ <p>solution <i>Step 1.</i> Using Eq. (3.2), calculate the stress (σ_{axial}) as</p> $\begin{aligned} \sigma_{\text{axial}} &= \frac{p_i r_m}{2t} = \frac{(2,100,000 \text{ N/m}^2)(.8 \text{ m})}{2(0.01 \text{ m})} \\ &= \frac{1,680,000 \text{ N/m}}{0.02 \text{ m}} \\ &= 8.4 \times 10^7 \text{ N/m}^2 = 84 \text{ MPa} \end{aligned}$ <p><i>Step 2.</i> Using Eq. (3.3), calculate the hoop stress (σ_{hoop}) as</p> $\begin{aligned} \sigma_{\text{hoop}} &= \frac{p_i r_m}{t} = \frac{(2,100,000 \text{ N/m}^2)(.8 \text{ m})}{(0.01 \text{ m})} \\ &= \frac{1,680,000 \text{ N/m}}{0.01 \text{ m}} \\ &= 1.68 \times 10^8 \text{ N/m}^2 = 168 \text{ MPa} \end{aligned}$

3.2.2 Thick-Walled Cylinders

Thick-walled cylinders have application in all sorts of machine elements and will be the basis for the presentation in Sec. 3.1.3 on shrink or press fits. Typically a cylinder is considered *thick* if the diameter is less than ten times the wall thickness.

Geometry. The geometry of a thick-walled cylinder is shown in Fig. 3.3.

There is an internal pressure (p_i) associated with the inside radius (r_i), and an external pressure (p_o) associated with the outside radius (r_o). Unlike thin-walled vessels, thick-walled cylinders do not tend to buckle under excessive external pressure, but merely crush.

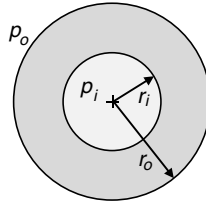

FIGURE 3.3 Geometry of a thick-walled cylinder.

The major difference between the stresses in a thin-walled cylinder and a thick-walled cylinder is that the hoop stress, also called the tangential stress, for the thick-walled cylinder varies in the radial direction, and there is a radial stress across the thickness of the cylinder that also varies radially.

Tangential Stress. For the geometry and pressures shown in Fig. 3.3, the tangential (hoop) stress (σ_t) is given by Eq. (3.4).

$$\sigma_t = \frac{p_i r_i^2 - p_o r_o^2 + (p_i - p_o)(r_i^2 r_o^2 / r^2)}{r_o^2 - r_i^2} \quad (3.4)$$

If the external pressure (p_o) is zero gage, meaning atmospheric, then the tangential stress (σ_t) becomes that given in Eq. (3.5)

$$\sigma_t = \frac{p_i r_i^2}{r_o^2 - r_i^2} \left[1 + \left(\frac{r_o}{r} \right)^2 \right] \quad (3.5)$$

The tangential stress (σ_t) distribution using Eq. (3.5) is shown in Fig. 3.4.

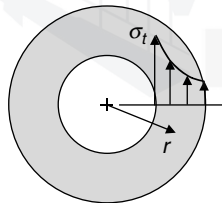

FIGURE 3.4 Tangential stress with $p_o = 0$.

Note that the tangential stress (σ_t) is maximum at the inside radius and a lower value at the outside radius. Also, if the outside radius is twice the inside radius, by a few algebra steps it can be shown that the tangential stress at the inside radius is two and a half times greater than the tangential stress at the outside radius.

Radial Stress. For the geometry and pressures shown in Fig. 3.3, the radial stress (σ_r) is given by Eq. (3.6).

$$\sigma_r = \frac{p_i r_i^2 - p_o r_o^2 - (p_i - p_o)(r_i^2 r_o^2 / r^2)}{r_o^2 - r_i^2} \quad (3.6)$$

If the external pressure (p_o) is zero gage, meaning atmospheric, then the radial stress σ_r becomes that given in Eq. (3.6), and is always compressive, that is, negative.

$$\sigma_r = \frac{p_i r_i^2}{r_o^2 - r_i^2} \left[1 - \left(\frac{r_o}{r} \right)^2 \right] \quad (3.7)$$

The radial stress σ_r distribution using Eq. (3.7) is shown in Fig. 3.5.

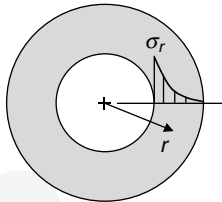

FIGURE 3.5 Radial stress with $p_o = 0$.

Note that the radial stress (σ_r) is a maximum at the inside radius and zero at the outside radius. Also notice that there are no arrows on the lines displaying the distribution like there were for the tangential stress distribution. This is because the radial stress is in the radial direction, so the length of the plain lines on the distribution curve represent the magnitude of the radial stress. (The arrows on the tangential stress distribution curve represented both magnitude and direction.)

U.S. Customary	SI/Metric
<p>Example 4. Calculate the maximum tangential stress (σ_t) and the maximum radial stress (σ_r) for a thick-walled cylinder, where</p> <p>$p_i = 450$ psi $p_o = 0$ psi (atmospheric) $r_i = 2$ in $r_o = 4$ in</p> <p>solution <i>Step 1.</i> Note that both the tangential stress (σ_t) and the radial stress (σ_r) are a maximum at the inside radius (r_i). So substitute the inside radius in Eq. (3.5) to obtain the tangential stress as</p> $\sigma_t = \frac{p_i r_i^2}{r_o^2 - r_i^2} \left[1 + \left(\frac{r_o}{r_i} \right)^2 \right]$ <p>and in Eq. (3.7) to obtain the radial stress as</p> $\sigma_r = \frac{p_i r_i^2}{r_o^2 - r_i^2} \left[1 - \left(\frac{r_o}{r_i} \right)^2 \right]$	<p>Example 4. Calculate the maximum tangential stress (σ_t) and the maximum radial stress (σ_r) for a thick-walled cylinder, where</p> <p>$p_i = 3.15$ MPa = 3,150,000 N/m² $p_o = 0$ psi (atmospheric) $r_i = 5$ cm = 0.05 m $r_o = 10$ cm = 0.1 m</p> <p>solution <i>Step 1.</i> Note that both the tangential stress (σ_t) and the radial stress (σ_r) are a maximum at the inside radius (r_i). So substitute the inside radius in Eq. (3.5) to obtain the tangential stress as</p> $\sigma_t = \frac{p_i r_i^2}{r_o^2 - r_i^2} \left[1 + \left(\frac{r_o}{r_i} \right)^2 \right]$ <p>and in Eq. (3.7) to obtain the radial stress as</p> $\sigma_r = \frac{p_i r_i^2}{r_o^2 - r_i^2} \left[1 - \left(\frac{r_o}{r_i} \right)^2 \right]$

U.S. Customary	SI/Metric
<p><i>Step 2.</i> Substitute the pressure (p_i), the inside radius (r_i), and the outside radius (r_o) into these two expressions to obtain</p> $\begin{aligned}\sigma_t &= \frac{p_i r_i^2}{r_o^2 - r_i^2} \left[1 + \left(\frac{r_o}{r_i} \right)^2 \right] \\ &= \frac{(450 \text{ lb/in}^2)(2 \text{ in})^2}{(4 \text{ in})^2 - (2 \text{ in})^2} \\ &\quad \times \left[1 + \left(\frac{4 \text{ in}}{2 \text{ in}} \right)^2 \right] \\ &= \frac{1,800 \text{ lb}}{12 \text{ in}^2}(1 + 4) \\ &= (150 \text{ lb/in}^2)(5) \\ &= 750 \text{ lb/in}^2 = 750 \text{ psi}\end{aligned}$ <p>and</p> $\begin{aligned}\sigma_r &= \frac{p_i r_i^2}{r_o^2 - r_i^2} \left[1 - \left(\frac{r_o}{r_i} \right)^2 \right] \\ &= \frac{(450 \text{ lb/in}^2)(2 \text{ in})^2}{(4 \text{ in})^2 - (2 \text{ in})^2} \\ &\quad \times \left[1 - \left(\frac{4 \text{ in}}{2 \text{ in}} \right)^2 \right] \\ &= \frac{1,800 \text{ lb}}{12 \text{ in}^2}(1 - 4) \\ &= (150 \text{ lb/in}^2)(-3) \\ &= -450 \text{ lb/in}^2 = -450 \text{ psi} \\ &= -p_i\end{aligned}$	<p><i>Step 2.</i> Substitute the pressure (p_i), the inside radius (r_i), and the outside radius (r_o) into these two expressions to obtain</p> $\begin{aligned}\sigma_t &= \frac{p_i r_i^2}{r_o^2 - r_i^2} \left[1 + \left(\frac{r_o}{r_i} \right)^2 \right] \\ &= \frac{(3,150,000 \text{ N/m}^2)(0.05 \text{ m})^2}{(0.1 \text{ m})^2 - (0.05 \text{ m})^2} \\ &\quad \times \left[1 + \left(\frac{0.1 \text{ m}}{0.05 \text{ m}} \right)^2 \right] \\ &= \frac{7,875 \text{ N}}{0.0075 \text{ m}^2}(1 + 4) \\ &= (1,050,000 \text{ N/m}^2)(5) \\ &= 5,250,000 \text{ N/m}^2 = 5.25 \text{ MPa}\end{aligned}$ <p>and</p> $\begin{aligned}\sigma_r &= \frac{p_i r_i^2}{r_o^2 - r_i^2} \left[1 - \left(\frac{r_o}{r_i} \right)^2 \right] \\ &= \frac{(3,150,000 \text{ N/m}^2)(0.05 \text{ m})^2}{(0.1 \text{ m})^2 - (0.05 \text{ m})^2} \\ &\quad \times \left[1 - \left(\frac{0.1 \text{ m}}{0.05 \text{ m}} \right)^2 \right] \\ &= \frac{7,875 \text{ N}}{0.0075 \text{ m}^2}(1 - 4) \\ &= (1,050,000 \text{ N/m}^2)(-3) \\ &= -3,150,000 \text{ N/m}^2 = -3.15 \text{ MPa} \\ &= -p_i\end{aligned}$

The maximum radial stress (σ_r^{\max}) occurs at the inside radius, and is the negative of the internal pressure (p_i). The algebraic steps to show this fact are given in Eq. (3.8).

$$\sigma_r^{\max} = \underbrace{\frac{p_i r_i^2}{r_o^2 - r_i^2} \left[1 - \left(\frac{r_o}{r_i} \right)^2 \right]}_{\text{Eq. (1.55) with } r = r_i} = \underbrace{\frac{p_i r_i^2}{r_o^2 - r_i^2} \left[\frac{r_i^2 - r_o^2}{r_i^2} \right]}_{\text{find common denominator}} = \underbrace{\frac{p_i r_i^2}{r_i^2} \left[\frac{-(r_o^2 - r_i^2)}{r_o^2 - r_i^2} \right]}_{\text{rearrange and cancel terms}} = -p_i \quad (3.8)$$

Axial Stress. If the pressure (p_i) is confined at the ends, an axial stress (σ_a) is also developed. The geometry and stresses, including the tangential stress (σ_t), are shown in Fig. 3.6.

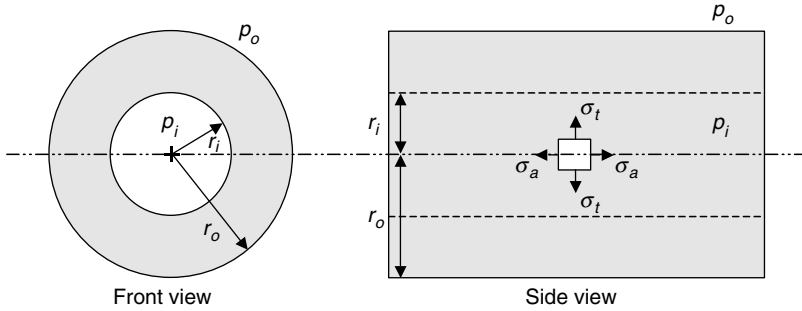

FIGURE 3.6 Geometry and stresses in a thick-walled cylinder.

Using the geometry of Fig. 3.6, the axial stress (σ_a) is given by Eq. (3.9) as

$$\sigma_a = \frac{p_i r_i^2}{r_o^2 - r_i^2} \tag{3.9}$$

It is interesting to note that Eq. (3.9) reduces to Eq. (3.2) for a thin-walled cylinder, where the inside radius (r_i) and the outside radius (r_o) are approximately the mean radius (r_m), and their difference is the thickness (t). The algebraic steps are shown in Eq. (3.10).

$$\sigma_a = \frac{p_i r_i^2}{r_o^2 - r_i^2} = \frac{p_i r_i^2}{(r_o + r_i)(r_o - r_i)} = \frac{p_i r_m^2}{(r_m + r_m)(t)} = \frac{p_i r_m^2}{(2 r_m)(t)} = \frac{p_i r_m}{2 t} \tag{3.10}$$

Eq. (1.57) expand denominator substitute for r_m & t combine terms Eq.(1.50)

U.S. Customary	SI/Metric
<p>Example 5. Calculate the axial stress (σ_a) for the thick-walled cylinder in Example 1.</p> <p>solution <i>Step 1.</i> Substitute the pressure (p_i), the inside radius (r_i), and the outside radius (r_o) in Eq. (3.9) to obtain</p> $\begin{aligned} \sigma_t &= \frac{p_i r_i^2}{r_o^2 - r_i^2} \\ &= \frac{(450 \text{ lb/in}^2)(2 \text{ in})^2}{(4 \text{ in})^2 - (2 \text{ in})^2} \\ &= \frac{1,800 \text{ lb}}{12 \text{ in}^2} \\ &= 150 \text{ lb/in}^2 = 150 \text{ psi} \end{aligned}$	<p>Example 5. Calculate the axial stress (σ_a) for the thick-walled cylinder in Example 1.</p> <p>solution <i>Step 1.</i> Substitute the pressure (p_i), the inside radius (r_i), and the outside radius (r_o) in Eq. (3.9) to obtain</p> $\begin{aligned} \sigma_t &= \frac{p_i r_i^2}{r_o^2 - r_i^2} \\ &= \frac{(3,150,000 \text{ N/m}^2)(0.05 \text{ m})^2}{(0.1 \text{ m})^2 - (0.05 \text{ m})^2} \\ &= \frac{7,875 \text{ N}}{0.0075 \text{ m}^2} \\ &= 1,050,000 \text{ N/m}^2 = 1.05 \text{ MPa} \end{aligned}$

3.2.3 Press or Shrink Fits

If two thick-walled cylinders are assembled by either a hot/cold shrinking or a mechanical press-fit, a pressure is developed at the interface between the two cylinders. At the interface

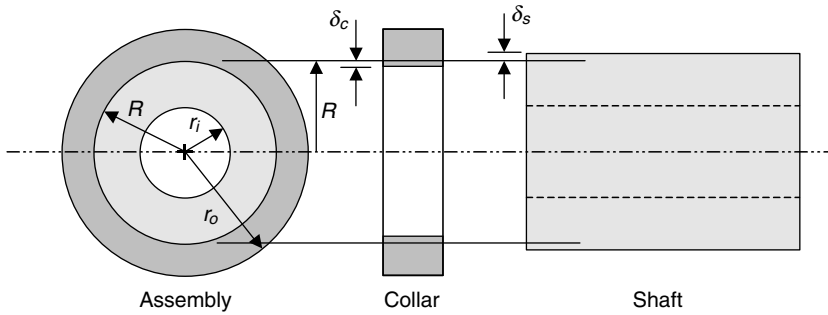

FIGURE 3.7 Geometry of a press or shrink fit collar and shaft.

between the two cylinders, at a radius (R), the outside cylinder, or collar, increases an amount (δ_c) radially, and the inside cylinder, or shaft, decreases an amount (δ_s) radially. The geometry of an outer collar on an inner shaft assembly is shown in Fig. 3.7.

The increase in the outside cylinder, or collar, radially (δ_c) is given by Eq. (3.11),

$$\delta_c = \frac{pR}{E_c} \left(\frac{r_o^2 + R^2}{r_o^2 - R^2} + \nu_c \right) \quad (3.11)$$

and the decrease in the inside cylinder, or shaft, radially (δ_s) is given by Eq. (3.12),

$$\delta_s = -\frac{pR}{E_s} \left(\frac{R^2 + r_i^2}{R^2 - r_i^2} - \nu_s \right) \quad (3.12)$$

where (E_c) and (ν_c) and (E_s) and (ν_s) are the modulus of elasticity's and Poisson ratio's of the collar and shaft, respectively. The difference between the radial increase (δ_c) of the collar, a positive number, and the radial decrease (δ_s) of the shaft, a negative number, is called the radial interference (δ) at the interface (R) and is given by Eq. (3.13).

$$\delta = \delta_c + |\delta_s| = \frac{pR}{E_c} \left(\frac{r_o^2 + R^2}{r_o^2 - R^2} + \nu_c \right) + \frac{pR}{E_s} \left(\frac{R^2 + r_i^2}{R^2 - r_i^2} - \nu_s \right) \quad (3.13)$$

When the radial interference (δ) is determined from a particular fit specification, Eq. (3.13) can be solved for the interference pressure (p). More about fit specifications is presented later in this section.

If the collar and shaft are made of the same material, then the modulus of elasticity's and Poisson ratio's are equal and so Eq. (3.13) can be rearranged to give an expression for the interface pressure (p) given in Eq. (3.14).

$$p = \frac{E\delta}{R} \left[\frac{(r_o^2 - R^2)(R^2 - r_i^2)}{2R^2(r_o^2 - r_i^2)} \right] \quad (3.14)$$

If the inner shaft is solid, meaning the inside radius (r_i) is zero, then Eq. (3.14) for the interface pressure (p) simplifies to the expression in Eq. (3.15).

$$p = \frac{E\delta}{2R} \left[1 - \left(\frac{R}{r_o} \right)^2 \right] \quad (3.15)$$

U.S. Customary	SI/Metric
<p>Example 6. Calculate the interface pressure (p) for a solid shaft and collar assembly, with both parts steel, where</p> <p>$\delta = 0.0005$ in $R = 2$ in $r_o = 3$ in $E = 30 \times 10^6$ lb/in² (steel)</p> <p>solution <i>Step 1.</i> Substitute the radial interface (δ), interface radius (R), outside radius (r_o) of the collar, and the modulus of elasticity (E) in Eq. (3.15) to give</p> $p = \frac{E\delta}{2R} \left[1 - \left(\frac{R}{r_o} \right)^2 \right]$ $= \frac{(30 \times 10^6 \text{ lb/in}^2)(0.0005 \text{ in})}{2(2 \text{ in})}$ $\times \left[1 - \left(\frac{2 \text{ in}}{3 \text{ in}} \right)^2 \right]$ $= \frac{15,000 \text{ lb/in}}{4 \text{ in}} (1 - 0.44)$ $= (3,750 \text{ lb/in}^2)(0.56)$ $= 2,100 \text{ lb/in}^2 = 2.1 \text{ kpsi}$	<p>Example 6. Calculate the interface pressure (p) for a solid shaft and collar assembly, with both parts steel, where</p> <p>$\delta = 0.001$ cm = 0.00001 m $R = 5$ cm = 0.05 m $r_o = 8$ cm = 0.08 m $E = 207 \times 10^9$ N/m² (steel)</p> <p>solution <i>Step 1.</i> Substitute the radial interface (δ), interface radius (R), outside radius (r_o) of the collar, and the modulus of elasticity (E) in Eq. (3.15) to give</p> $p = \frac{E\delta}{2R} \left[1 - \left(\frac{R}{r_o} \right)^2 \right]$ $= \frac{(207 \times 10^9 \text{ N/m}^2)(0.00001 \text{ m})}{2(0.05 \text{ m})}$ $\times \left[1 - \left(\frac{0.05 \text{ m}}{0.08 \text{ m}} \right)^2 \right]$ $= \frac{2,070,000 \text{ N/m}}{0.1 \text{ m}} (1 - 0.39)$ $= (20,700,000 \text{ N/m}^2)(0.61)$ $= 12,627,000 \text{ N/m}^2 = 12.6 \text{ MPa}$

Fit Terminology. When the radial interference (δ) and interface radius (R) is known, as in Example 1, the interface pressure (p) can be calculated from either Eq. (3.13), (3.14), or (3.15) depending on whether the collar and shaft are made of the same material, and depending on whether the shaft is solid or hollow.

The radial interference (δ) and the interface radius (R) are actually determined from interference *fits* established by ANSI (American National Standards Institute) standards. There are ANSI standards for both the U.S. customary and metric systems of units.

As the interference (δ) is associated with the changes in the radial dimensions, it can be expressed in terms of the outside diameter d_{shaft} of the shaft and the inside diameter D_{hole} of the collar given in Eq. (3.16).

$$\delta = \frac{1}{2} (d_{\text{shaft}} - D_{\text{hole}}) = \delta_c + |\delta_s| \quad (3.16)$$

By convention, uppercase letters are used for the dimensions of the hole in the collar, whereas lowercase letters are used for the dimensions of the shaft. Also, the radial increase

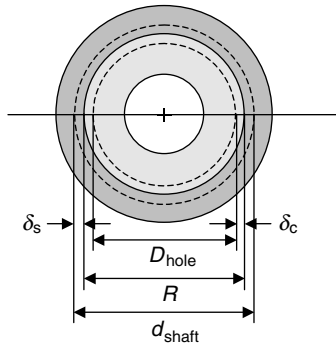

FIGURE 3.8 Geometry of the radial interference (δ).

(δ_c) is always positive and the radial decrease (δ_s) is always negative, which is why the absolute value of (δ_s) is added to (δ_c). The geometry of the terms in Eq. (3.16) is shown in Fig. 3.8.

Fit Standards. For either the U.S. customary or metric systems of units, *Marks' Standard Handbook for Mechanical Engineers* contains an exhaustive discussion of the standards for press or shrink fits. To summarize, fits are separated into five categories:

1. Loose running and sliding fits
2. Locational clearance fits
3. Locational transition fits
4. Locational interference fits
5. Force or drive and shrink fits

Only for the fifth category, force or drive and shrink fits, does a significant interface pressure (p) develop between the shaft and collar assembly, again given by either Eq. (3.13), (3.14), or (3.15) depending on the materials of the shaft and collar, and whether the shaft is hollow or solid. Note that if the interface pressure (p) exceeds the yield stress of either the collar or the shaft, plastic deformation takes place and the stresses are different than the interface pressure calculated.

When using specific fit standards, whether U.S. customary or metric, the radial interference (δ) given by Eq. (3.16) needs to be separated into two different calculations. There needs to be a calculation of the maximum radial interference (δ_{\max}) to be expected that is given by Eq. (3.17)

$$\delta_{\max} = \frac{1}{2} (d_{\text{shaft}}^{\max} - D_{\text{hole}}^{\min}) \quad (3.17)$$

where (d_{shaft}^{\max}) is the maximum diameter of the shaft and (D_{hole}^{\min}) is the minimum diameter of the hole in the collar. There should also be a calculation of the minimum radial interference (δ_{\min}) to be expected and given by Eq. (3.18),

$$\delta_{\min} = \frac{1}{2} (d_{\text{shaft}}^{\min} - D_{\text{hole}}^{\max}) \quad (3.18)$$

where (d_{shaft}^{\min}) is the minimum diameter of the shaft and (D_{hole}^{\max}) is the maximum diameter of the hole in the collar. Many times the minimum radial interference (δ_{\min}) is zero, so the interface pressure (p) will also be zero.

U.S. Customary	SI/Metric
<p>Example 7. Given a set of standard fit dimensions, calculate the maximum and minimum radial interferences, (δ_{\max}) and (δ_{\min}), and the associated interface pressures, (p_{\max}) and (p_{\min}), for a solid shaft and collar assembly, with both parts aluminum, where</p> <p>Hole: $D_{\max} = 1.5010$ in $D_{\min} = 1.5000$ in Shaft: $d_{\max} = 1.5016$ in $d_{\min} = 1.5010$ in $R = 1.5$ in $r_o = 3$ in $E = 11 \times 10^6$ lb/in² (aluminum)</p> <p>solution <i>Step 1.</i> Calculate the maximum radial interference (δ_{\max}) from Eq. (3.17) as</p> $\begin{aligned}\delta_{\max} &= \frac{1}{2} \left(d_{\text{shaft}}^{\max} - D_{\text{hole}}^{\min} \right) \\ &= \frac{1}{2} (1.5016 \text{ in} - 1.5000 \text{ in}) \\ &= \frac{1}{2} (0.0016 \text{ in}) \\ &= 0.0008 \text{ in}\end{aligned}$ <p><i>Step 2.</i> Calculate the minimum radial interference (δ_{\min}) from Eq. (3.18) as</p> $\begin{aligned}\delta_{\min} &= \frac{1}{2} \left(d_{\text{shaft}}^{\min} - D_{\text{hole}}^{\max} \right) \\ &= \frac{1}{2} (1.5010 \text{ in} - 1.5010 \text{ in}) \\ &= \frac{1}{2} (0.0000 \text{ in}) \\ &= 0 \text{ in}\end{aligned}$ <p><i>Step 3.</i> Using the maximum radial interface (δ_{\max}) found in Step 1, calculate the maximum interface pressure (p_{\max}) from Eq. (3.15) as</p> $\begin{aligned}p_{\max} &= \frac{E\delta_{\max}}{2R} \left[1 - \left(\frac{R}{r_o} \right)^2 \right] \\ &= \frac{(11 \times 10^6 \text{ lb/in}^2) (0.0008 \text{ in})}{2 (1.5 \text{ in})} \\ &\quad \times \left[1 - \left(\frac{1.5 \text{ in}}{3 \text{ in}} \right)^2 \right] \\ &= \frac{8,800 \text{ lb/in}}{3 \text{ in}} (1 - 0.25) \\ &= (2,933 \text{ lb/in}^2)(0.75) \\ &= 2,200 \text{ lb/in}^2 = 2.2 \text{ kpsi}\end{aligned}$	<p>Example 7. Given a set of standard fit dimensions, calculate the maximum and minimum radial interferences, (δ_{\max}) and (δ_{\min}), and the associated interface pressures, (p_{\max}) and (p_{\min}), for a solid shaft and collar assembly, with both parts aluminum, where</p> <p>Hole: $D_{\max} = 4.0025$ cm $D_{\min} = 4.0000$ cm Shaft: $d_{\max} = 4.0042$ cm $d_{\min} = 4.0026$ cm $R = 4.0$ cm = 0.04 m $r_o = 8.0$ cm = 0.08 m $E = 77 \times 10^9$ N/m² (aluminum)</p> <p>solution <i>Step 1.</i> Calculate the maximum radial interference (δ_{\max}) from Eq. (3.17) as</p> $\begin{aligned}\delta_{\max} &= \frac{1}{2} \left(d_{\text{shaft}}^{\max} - D_{\text{hole}}^{\min} \right) \\ &= \frac{1}{2} (4.0042 \text{ cm} - 4.0000 \text{ cm}) \\ &= \frac{1}{2} (0.0042 \text{ cm}) \\ &= 0.0021 \text{ cm} = 0.000021 \text{ m}\end{aligned}$ <p><i>Step 2.</i> Calculate the maximum radial interference (δ_{\min}) from Eq. (3.18) as</p> $\begin{aligned}\delta_{\min} &= \frac{1}{2} \left(d_{\text{shaft}}^{\min} - D_{\text{hole}}^{\max} \right) \\ &= \frac{1}{2} (4.0026 \text{ cm} - 4.0025 \text{ cm}) \\ &= \frac{1}{2} (0.0001 \text{ cm}) \\ &= 0.00005 \text{ cm} = 0.0000005 \text{ m}\end{aligned}$ <p><i>Step 3.</i> Using the maximum radial interface (δ_{\max}) found in Step 1, calculate the maximum interface pressure (p_{\max}) from Eq. (3.15) as</p> $\begin{aligned}p_{\max} &= \frac{E\delta_{\max}}{2R} \left[1 - \left(\frac{R}{r_o} \right)^2 \right] \\ &= \frac{(77 \times 10^9 \text{ N/m}^2) (0.000021 \text{ m})}{2 (0.04 \text{ m})} \\ &\quad \times \left[1 - \left(\frac{0.04 \text{ m}}{0.08 \text{ m}} \right)^2 \right] \\ &= \frac{1,617,000 \text{ N/m}}{0.08 \text{ m}} (1 - 0.25) \\ &= (20,212,500 \text{ N/m}^2)(0.75) \\ &= 15,160,000 \text{ N/m}^2 = 15.2 \text{ MPa}\end{aligned}$

U.S. Customary	SI/Metric
<p><i>Step 4.</i> As the minimum radial interface (δ_{\min}) calculated from Step 2 is zero, the minimum interface pressure (p_{\min}) is also zero. So,</p> $p_{\min} = 0$	<p><i>Step 4.</i> As the minimum radial interface (δ_{\min}) calculated from Step 2 is very small, the minimum interface pressure (p_{\min}) is</p> $p_{\min} = 0$

3.3 CONTACT LOADING

Contact loading occurs between machine elements such as rolling metal wheels, meshing of gear teeth, and within the entire spectrum of bearings. The discussion on contact loading will be divided into two main areas:

1. Spheres in contact
2. Cylinders in contact

In contact loading, an initial point (spheres) or line (cylinders) of contact develops into an area of contact over which the load must be distributed. As these areas are typically very small, the associated stresses can be quite large. The location of maximum stress can actually occur below the surface of the machine element, causing catastrophic failure without prior visible warning. For this reason, understanding the principles and stress equations that follow are important to the machine designer.

3.3.1 Spheres in Contact

Two spheres of different diameters are shown in Fig. 3.9 being compressed by two forces (F). The (x) and (y) axes define the plane of contact between the spheres, and the (z) axis defines the distance to either sphere. The two different diameters are denoted (d_1) and (d_2). For contact with a flat surface, set either diameter to infinity (∞). For an internal surface contact, enter the larger diameter as a negative quantity.

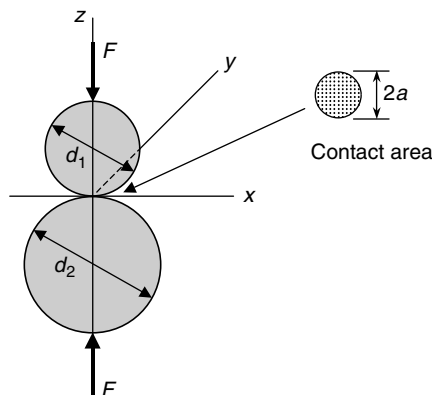

FIGURE 3.9 Spheres in contact.

If the two spheres are made of two different materials, then the radius (a) of the area of contact is given by Eq. (3.19),

$$a = \sqrt[3]{\frac{3F}{8} \frac{\frac{(1-\nu_1^2)}{E_1} + \frac{(1-\nu_2^2)}{E_2}}{\frac{1}{d_1} + \frac{1}{d_2}}} \quad (3.19)$$

where (ν) is Poisson's ratio and (E) is the modulus of elasticity.

As stated earlier, if one of the spheres contacts a flat surface, then set one of the diameters to infinity (∞). In addition, if the sphere and the flat surface are the same material, then the radius (a) of the contact given in Eq. (3.19) becomes Eq. (3.20).

$$a = \sqrt[3]{\frac{3F}{8} \frac{2(1-\nu^2)d}{E}} = \sqrt[3]{\frac{3F(1-\nu^2)d}{4E}} \quad (3.20)$$

The pressure distribution over the area of contact is elliptical with the maximum pressure (p_{\max}), which is a negative stress, occurring at the center of the contact area and given by Eq. (3.21),

$$p_{\max} = \frac{3F}{2\pi a^2} \quad (3.21)$$

where the radius (a) is found either from Eq. (3.19) or Eq. (3.20).

Without providing the details of the development, the largest values of the stresses within the two spheres, which are all principal stresses, occur on three-dimensional stress elements along the (z) axis where ($x = 0$) and ($y = 0$). Using the axes notation from Fig. 3.9: (x), (y), and (z), instead of the standard notation for principal stresses: (1), (2), and (3), the three principal stresses, two of which are equal, are given by the following equations.

$$\sigma_x = \sigma_y = -p_{\max} \left[(1 + \nu) \left(1 - \frac{z}{a} \tan^{-1} \frac{1}{\frac{z}{a}} \right) - \left(\frac{1}{2 \left(1 + \frac{z^2}{a^2} \right)} \right) \right] \quad (3.22)$$

$$\sigma_z = \frac{-p_{\max}}{1 + \frac{z^2}{a^2}} \quad (3.23)$$

There are three things to notice about Eqs. (3.22) and (3.23). First, Poisson's ratio (ν) in Eq. (3.22) is for the sphere of interest, either (ν_1) or (ν_2). Second, the maximum pressure (p_{\max}) calculated from Eq. (3.21) is a positive number, so the minus sign in Eqs. (3.22) and (3.23) makes all three principal stresses negative, or compressive. Third, as the principal stress (σ_z) has the largest magnitude, but negative, and as the three principal stresses form a triaxial stress element, the maximum shear stress (τ_{\max}) is given by Eq. (3.24) as

$$\tau_{\max} = \frac{\sigma_x - \sigma_z}{2} = \frac{\sigma_y - \sigma_z}{2} \quad (3.24)$$

To determine the maximum shear stress (τ_{\max}) at the plane of contact between the two spheres, substitute $z = 0$ in Eqs. (3.22) and (3.23) to give

$$\begin{aligned} \sigma_x = \sigma_y &= -p_{\max} \left[(1 + \nu) \left(1 - \frac{0}{a} \tan^{-1} \frac{1}{\frac{0}{a}} \right) - \left(\frac{1}{2 \left(1 + \frac{0^2}{a^2} \right)} \right) \right] \\ &= -p_{\max} \left[(1 + \nu)(1) - \left(\frac{1}{2(1)} \right) \right] = -p_{\max} \left(\frac{1}{2} + \nu \right) \end{aligned} \quad (3.25)$$

$$\sigma_z = \frac{-p_{\max}}{1 + \frac{0^2}{a^2}} = -p_{\max} \quad (3.26)$$

Substitute either (σ_x) or (σ_y) from Eq. (3.25) and (σ_z) from Eq. (3.26) in Eq. (3.24) to give the maximum shear stress (τ_{max}) at the plane of contact as

$$\begin{aligned} \tau_{max} &= \frac{\sigma_x - \sigma_z}{2} = \frac{\sigma_y - \sigma_z}{2} = \frac{[-p_{max}(\frac{1}{2} + \nu)] - [-p_{max}]}{2} \\ &= \frac{[-p_{max}(\frac{1}{2} + \nu)] + p_{max}}{2} = \frac{p_{max}(1 - \frac{1}{2} - \nu)}{2} \\ &= \frac{p_{max}(\frac{1}{2} - \nu)}{2} = p_{max}\left(\frac{1}{4} - \frac{\nu}{2}\right) \end{aligned} \tag{3.27}$$

Even though the principal stresses are a maximum at the plane of contact ($z = 0$), it turns out that the maximum value of the maximum shear stress (τ_{max}) does not occur at ($z = 0$) but at some small distance into the sphere. Typically this small distance is between zero and half the radius of the contact area ($a/2$). This explains what is seen in practice where a spherical ball bearing develops a crack internally, then as the crack propagates to the surface of the ball it eventually allows lubricant in the bearing to enter the crack and fracture the ball bearing catastrophically by hydrostatic pressure.

The relative distributions of the principal stresses, normalized to the maximum pressure (p_{max}) , are shown in Fig. 3.10, where a Poisson ratio ($\nu = 0.3$), which is close to that for steel, has been used. Again, notice that the maximum value of the maximum shear stress (τ_{max}) does not occur at the surface ($z = 0$), but is at a distance of about 0.4 times the radius of the contact area (a), and has a value close to 0.3 times the maximum pressure (p_{max}) . Also, observe that the values of the principal stresses at the plane of contact ($z = 0$) agree with the calculations in Eqs. (3.25), (3.26), and (3.27) for a Poisson ratio ($\nu = 0.3$).

Remember that the curves for the three principal stresses shown in Fig. 3.10 are for a Poisson ratio ($\nu = 0.3$). For other Poisson ratio's, a different set of curves would need to be drawn. Also, as the stress elements along the (z) axis are triaxial, the design is safe if the maximum value of the maximum shear stress (τ_{max}) is less than the shear yield

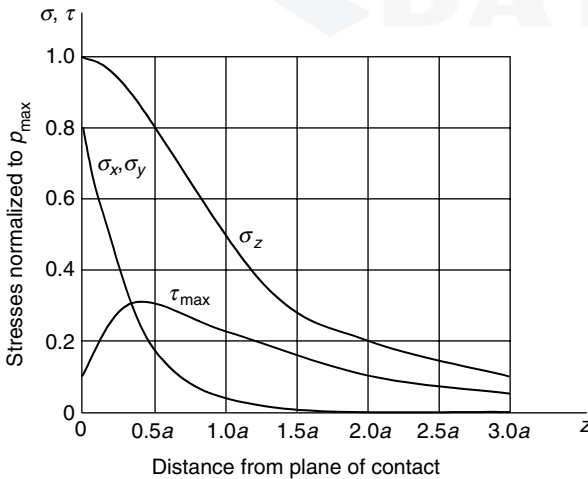

FIGURE 3.10 Principal stress distributions (spheres).

strength in compression that was found in the previous section to be half the yield stress (S_y). Converting this statement into a factor-of-safety expression is given in Eq. (3.28) as

$$\tau_{\max} < S_{sy} = \frac{S_y}{2} \rightarrow \frac{\tau_{\max}}{\frac{S_y}{2}} = \frac{1}{n} \quad (3.28)$$

For the next example, consider a Mars rover with solid spherical titanium alloy wheels, which during testing on Earth, is driven over flat granite rock to simulate the Mars landscape. The rover has four wheels that carry the total load evenly.

U.S. Customary	SI/Metric
<p>Example 1. Determine whether the design of the titanium wheels for the rover described above will be safe during the test on granite rock, where</p> <p>$W = 8,000 \text{ lb} = 4 \text{ F}$ $d_{\text{wheel}} = 3 \text{ ft} = 36 \text{ in}, d_{\text{rock}} = \infty$ $S_y = 110 \text{ kpsi (titanium)}$ $\nu_1 = 0.33 \text{ (titanium)}$ $E_1 = 15 \times 10^3 \text{ kpsi} = 15 \text{ Mpsi (titanium)}$ $\nu_2 = 0.3 \text{ (granite)}$ $E_2 = 10 \times 10^3 \text{ kpsi} = 10 \text{ Mpsi (granite)}$</p> <p>solution <i>Step 1.</i> Using Eq. (3.19), calculate the radius of the contact area (a) as</p> $a = \sqrt[3]{\frac{3F}{8} \frac{\frac{(1-\nu_1^2)}{E_1} + \frac{(1-\nu_2^2)}{E_2}}{\frac{1}{d_1} + \frac{1}{d_2}}}$ $= \sqrt[3]{\frac{3(2,000 \text{ lb})}{8} \frac{\frac{1 - 0.33^2}{15 \text{ Mpsi}} + \frac{1 - 0.3^2}{10 \text{ Mpsi}}}{\frac{1}{36 \text{ in}} + \frac{1}{\infty}}}$ $= \sqrt[3]{(750)(36) \left(\frac{0.89}{15 \times 10^6} + \frac{0.91}{10 \times 10^6} \right) \text{ in}^3}$ $= \sqrt[3]{(750)(36) (1.5 \times 10^{-7}) \text{ in}^3}$ $= \sqrt[3]{(4.06 \times 10^{-3}) \text{ in}^3}$ $= 0.16 \text{ in}$ <p><i>Step 2.</i> Using Eq. (3.21) calculate the maximum pressure (p_{\max})</p> $p_{\max} = \frac{3F}{2\pi a^2}$ $= \frac{3(2,000 \text{ lb})}{2\pi(0.16 \text{ in})^2} = \frac{6,000 \text{ lb}}{0.16 \text{ in}^2}$ $= 37,302 \text{ lb/in}^2$ $= 37.3 \text{ kpsi}$	<p>Example 1. Determine whether the design of the titanium wheels for the rover described above will be safe during the test on granite rock, where</p> <p>$W = 36,000 \text{ N} = 4 \text{ F}$ $d_{\text{wheel}} = 1 \text{ m}, d_{\text{rock}} = \infty$ $S_y = 770 \text{ MPa (titanium)}$ $\nu_1 = 0.33 \text{ (titanium)}$ $E_1 = 105 \text{ GPa (titanium)}$ $\nu_2 = 0.3 \text{ (granite)}$ $E_2 = 70 \text{ GPa (granite)}$</p> <p>solution <i>Step 1.</i> Using Eq. (3.19), calculate the radius of the contact area (a) as</p> $a = \sqrt[3]{\frac{3F}{8} \frac{\frac{(1-\nu_1^2)}{E_1} + \frac{(1-\nu_2^2)}{E_2}}{\frac{1}{d_1} + \frac{1}{d_2}}}$ $= \sqrt[3]{\frac{3(9,000 \text{ N})}{8} \frac{\frac{1 - 0.33^2}{105 \text{ GPa}} + \frac{1 - 0.3^2}{70 \text{ GPa}}}{\frac{1}{1 \text{ m}} + \frac{1}{\infty}}}$ $= \sqrt[3]{(3,375) \left(\frac{0.89}{105 \times 10^9} + \frac{0.91}{70 \times 10^9} \right) \text{ m}^3}$ $= \sqrt[3]{(3,375) (2.15 \times 10^{-11}) \text{ m}^3}$ $= \sqrt[3]{(7.25 \times 10^{-8}) \text{ m}^3}$ $= 0.0042 \text{ m} = 0.42 \text{ cm}$ <p><i>Step 2.</i> Using Eq. (3.21) calculate the maximum pressure (p_{\max}).</p> $p_{\max} = \frac{3F}{2\pi a^2}$ $= \frac{3(9,000 \text{ N})}{2\pi(0.0042 \text{ m})^2} = \frac{27,000 \text{ N}}{0.00011 \text{ m}^2}$ $= 243,600,000 \text{ N/m}^2$ $= 243.6 \text{ MPa}$

U.S. Customary	SI/Metric
<p><i>Step 3.</i> As Poisson's ratio (ν_1) for the titanium wheels is close to the 0.3 used to graph the principal stress equations in Fig. 3.10, assume the maximum shear stress occurs at 0.4a and is 0.3 p_{\max}. Therefore, using the value for the maximum pressure found in Step 2, the maximum shear stress (τ_{\max}) is</p> $\begin{aligned}\tau_{\max} &= 0.3 p_{\max} = (0.3)(37.3 \text{ kpsi}) \\ &= 11.2 \text{ kpsi}\end{aligned}$ <p><i>Step 4.</i> Using Eq. (3.28), calculate the factor-of-safety (n) for the design as</p> $\frac{\tau_{\max}}{\frac{S_y}{2}} = \frac{1}{n} = \frac{11.2 \text{ kpsi}}{\frac{110 \text{ kpsi}}{2}} = \frac{2(11.2)}{110} = 0.2$ $n = \frac{1}{0.2} = 5$ <p>Clearly the design is safe.</p>	<p><i>Step 3.</i> As Poisson's ratio (ν_1) for the titanium wheels is close to the 0.3 used to graph the principal stress equations in Fig. 3.10, assume the maximum shear stress occurs at 0.4a and is 0.3 p_{\max}. Therefore, using the value for the maximum pressure found in Step 2, the maximum shear stress (τ_{\max}) is</p> $\begin{aligned}\tau_{\max} &= 0.3 p_{\max} = (0.3)(243.6 \text{ MPa}) \\ &= 73.1 \text{ MPa}\end{aligned}$ <p><i>Step 4.</i> Using Eq. (3.28), calculate the factor-of-safety (n) for the design as</p> $\frac{\tau_{\max}}{\frac{S_y}{2}} = \frac{1}{n} = \frac{73.1 \text{ MPa}}{\frac{770 \text{ MPa}}{2}} = \frac{2(73.1)}{770} = 0.2$ $n = \frac{1}{0.2} = 5$ <p>Clearly the design is safe.</p>

3.3.2 Cylinders in Contact

Two cylinders of different diameters are shown in Fig. 3.11 being compressed by two forces (F). The (x) and (y) axes define the plane of contact between the cylinders, and the (z) axis defines the distance to either cylinder. The two different diameters are denoted (d_1) and (d_2). For contact with a flat surface, set either diameter to infinity (∞). For an internal surface contact, enter the larger diameter as a negative quantity.

The area of contact is a rectangle with the width equal to a small distance ($2b$) times the length (L) of the cylinders. If the two cylinders are made of two different materials, then

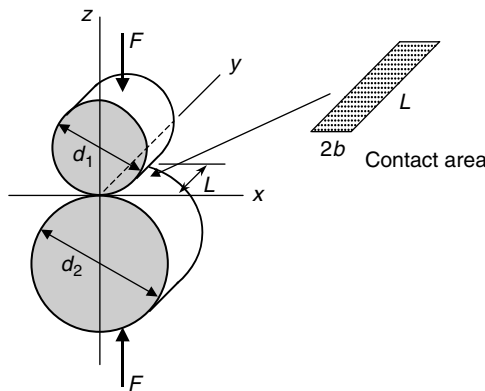

FIGURE 3.11 Cylinders in contact.

the distance (b) is given by Eq. (3.29),

$$b = \sqrt{\frac{2F}{\pi L} \frac{\frac{(1-\nu_1^2)}{E_1} + \frac{(1-\nu_2^2)}{E_2}}{\frac{1}{d_1} + \frac{1}{d_2}}} \quad (3.29)$$

where (ν) is Poisson's ratio and (E) is the modulus of elasticity.

As stated earlier, if one of the cylinders contacts a flat surface, then set one of the diameters to infinity (∞). In addition, if the cylinder and the flat surface are the same material, then the distance (b) of the contact given in Eq. (3.29) becomes Eq. (3.30).

$$b = \sqrt{\frac{2F}{\pi L} \frac{2(1-\nu^2)d}{E}} = \sqrt{\frac{4F}{\pi L} \frac{(1-\nu^2)d}{E}} \quad (3.30)$$

The pressure distribution over the area of contact is elliptical with the maximum pressure (p_{\max}), which is a negative stress, occurring at the center of the contact area and given by Eq. (3.31),

$$p_{\max} = \frac{2F}{\pi bL} \quad (3.31)$$

where the distance (b) is found from either Eq. (3.29) or Eq. (3.30).

Without providing the details of the development, the largest values of the stresses within the two cylinders, which are all principal stresses, occur on three-dimensional stress elements along the (z) axis where ($x = 0$) and ($y = 0$). Using the axes notation from Fig. 3.11: (x), (y), and (z), instead of the standard notation for principal stresses: (1), (2), and (3), the three principal stresses, all of which are different, are given by the following equations.

$$\sigma_x = -p_{\max} \left[\left(2 - \frac{1}{1 + \frac{z^2}{b^2}} \right) \sqrt{1 + \frac{z^2}{b^2}} - 2 \frac{z}{b} \right] \quad (3.32)$$

$$\sigma_y = -p_{\max}(2\nu) \left(\sqrt{1 + \frac{z^2}{b^2}} - \frac{z}{b} \right) \quad (3.33)$$

$$\sigma_z = \frac{-p_{\max}}{\sqrt{1 + \frac{z^2}{b^2}}} \quad (3.34)$$

There are three things to notice about Eqs. (3.32), (3.33), and (3.34). First, Poisson's ratio (ν) in Eq. (3.33) is for the cylinder of interest, either (ν_1) or (ν_2). Second, the maximum pressure (p_{\max}) calculated from Eq. (3.31) is a positive number, so the minus sign in Eqs. (3.32), (3.33), and (3.34) makes all three principal stresses negative, or compressive. Third, as the principal stress (σ_z) has the largest magnitude, but negative, and as the three principal stresses form a triaxial stress element, the maximum shear stress (τ_{\max}) is given by Eq. (3.35) as

$$\tau_{\max} = \frac{\sigma_x - \sigma_z}{2} \quad \text{or} \quad \frac{\sigma_y - \sigma_z}{2} \quad (3.35)$$

where the principal stresses (σ_x) and (σ_y) flip flop as to which is larger as the distance (z) varies into the cylinder of interest.

To determine the maximum shear stress (τ_{\max}) at the plane of contact between the two cylinders, substitute ($z = 0$) in Eqs. (3.32), (3.33), and (3.34) to give

$$\begin{aligned}\sigma_x &= -p_{\max} \left[\left(2 - \frac{1}{1 + \frac{0^2}{b^2}} \right) \sqrt{1 + \frac{0^2}{b^2}} - 2\frac{0}{b} \right] \\ &= -p_{\max} [(2 - 1)\sqrt{1} - 0] = -p_{\max}\end{aligned}\quad (3.36)$$

$$\begin{aligned}\sigma_y &= -p_{\max}(2\nu) \left(\sqrt{1 + \frac{0^2}{b^2}} - \frac{0}{b} \right) \\ &= -p_{\max}(2\nu)(\sqrt{1} - 0) = -p_{\max}(2\nu)\end{aligned}\quad (3.37)$$

$$\sigma_z = \frac{-p_{\max}}{\sqrt{1 + \frac{0^2}{b^2}}} = \frac{-p_{\max}}{\sqrt{1}} = -p_{\max}\quad (3.38)$$

As it is the largest, substitute (σ_x) from Eq. (3.36) and (σ_z) from Eq. (3.38) in Eq. (3.35) to give the maximum shear stress (τ_{\max}) at the plane of contact as

$$\begin{aligned}\tau_{\max} &= \frac{\sigma_x - \sigma_z}{2} = \frac{[-p_{\max}] - [-p_{\max}]}{2} \\ &= \frac{-p_{\max} + p_{\max}}{2} = \frac{0}{2} = 0\end{aligned}\quad (3.39)$$

Even though the principal stresses are a maximum at the plane of contact ($z = 0$), it turns out that the maximum value of the maximum shear stress (τ_{\max}) does not occur at ($z = 0$) but at some small distance into the cylinder. Typically this small distance is between one-half and one times the distance (b). This explains what is seen in practice where a cylindrical roller bearing develops a crack internally, then as the crack propagates to the surface of the roller it eventually allows lubricant in the bearing to enter the crack and fracture the roller bearing catastrophically by hydrostatic pressure.

The relative distributions of the principal stresses, normalized to the maximum pressure (p_{\max}), are shown in Fig. 3.12, where a Poisson ratio ($\nu = 0.3$), which is close to that for steel, has been used.

Again, notice that the maximum value of the maximum shear stress (τ_{\max}) does not occur at the surface ($z = 0$), but is at a distance of about 0.75 times the distance (b), and has a value close to 0.3 times the maximum pressure (p_{\max}). Also, observe that the values of the principal stresses at the plane of contact ($z = 0$) agree with the calculations in Eqs. (3.36), (3.37), and (3.38) for a Poisson ratio ($\nu = 0.3$).

Remember that the curves for the three principal stresses shown in Fig. 3.12 are for a Poisson ratio ($\nu = 0.3$). For other Poisson ratios, a different set of curves would need to be drawn. Also, as the stress elements along the (z) axis are triaxial, the design is safe if the maximum value of the maximum shear stress (τ_{\max}) is less than the shear yield strength in compression, that was found in the previous section to be half the yield stress (S_y). Converting this statement into a factor-of-safety expression is given in Eq. (3.40) as

$$\tau_{\max} < S_y = \frac{S_y}{2} \rightarrow \frac{\tau_{\max}}{\frac{S_y}{2}} = \frac{1}{n}\quad (3.40)$$

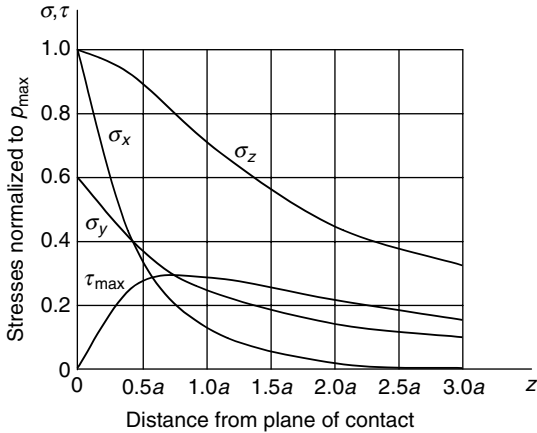

FIGURE 3.12 Principal stress distributions (cylinders).

For the next example, consider a railroad car with solid cylindrical steel wheels rolling on flat steel track. The railroad car has eight wheels that carry the total load evenly.

U.S. Customary	SI/Metric
<p>Example 2. Determine whether the design of the steel wheels for the railroad car described above will be safe during normal operations, where</p> <p>$W = 130 \text{ ton} = 260,000 \text{ lb} = 8 \text{ F}$ $d_{\text{wheel}} = 3 \text{ ft} = 36 \text{ in}$ $d_{\text{rail}} = \infty$ $L = 4 \text{ in}$ $S_y = 60 \text{ kpsi}$ (steel wheels) $\nu = 0.30$ (steel) $E = 30 \times 10^6 \text{ lb/in}^2$ (steel)</p> <p>solution <i>Step 1.</i> Using Eq. (3.30), calculate the distance (b) as</p> $b = \sqrt{\frac{4F(1-\nu^2)d}{\pi L E}}$ $= \sqrt{\frac{4(32,500 \text{ lb})(1-0.3^2)(36 \text{ in})}{\pi(4 \text{ in}) 30 \times 10^6 \text{ lb/in}^2}}$ $= \sqrt{\frac{(130,000)(32.76)}{(12.57) 30 \times 10^6} \text{ in}^2}$ $= \sqrt{(0.0113) \text{ in}^2}$ $= 0.11 \text{ in}$	<p>Example 2. Determine whether the design of the steel wheels for the railroad car described above will be safe during normal operations, where</p> <p>$W = 118 \text{ t} = 1,180 \text{ kN} = 8 \text{ F}$ $d_{\text{wheel}} = 1 \text{ m}$ $d_{\text{rail}} = \infty$ $L = 10 \text{ cm} = 0.1 \text{ m}$ $S_y = 420 \text{ MPa}$ (steel wheels) $\nu_1 = 0.30$ (steel) $E_1 = 210 \times 10^9 \text{ N/m}^2$ (steel)</p> <p>solution <i>Step 1.</i> Using Eq. (3.30), calculate the distance (b) as</p> $b = \sqrt{\frac{4F(1-\nu^2)d}{\pi L E}}$ $= \sqrt{\frac{4(147,500 \text{ N})(1-0.3^2)(1 \text{ m})}{\pi(0.1 \text{ m}) 210 \times 10^9 \text{ N/m}^2}}$ $= \sqrt{\frac{(590,000)(0.91)}{(0.31416) 210 \times 10^9} \text{ m}^2}$ $= \sqrt{(8.14 \times 10^{-6}) \text{ m}^2}$ $= 0.0028 \text{ m} = 0.28 \text{ cm}$

U.S. Customary	SI/Metric
<p><i>Step 2.</i> Using Eq. (3.31) calculate the maximum pressure (p_{\max}).</p> $p_{\max} = \frac{2F}{\pi bL}$ $= \frac{2(32,500 \text{ lb})}{\pi(0.11 \text{ in})(4 \text{ in})} = \frac{65,000 \text{ lb}}{1.38 \text{ in}^2}$ $= 47,025 \text{ lb/in}^2$ $= 47.0 \text{ kpsi}$ <p><i>Step 3.</i> As Poisson's ratio (ν) for the steel wheels is close to the 0.3 used to graph the principal stress equations in Fig. 3.12, assume the maximum shear stress occurs at 0.75b and is 0.3 p_{\max}. Therefore, using the value for the maximum pressure found in Step 2, the maximum shear stress (τ_{\max}) is</p> $\tau_{\max} = 0.3p_{\max} = (0.3)(47.0 \text{ kpsi})$ $= 14.1 \text{ kpsi}$ <p><i>Step 4.</i> Using Eq. (3.40), calculate the factor-of-safety (n) for the design as</p> $\frac{\tau_{\max}}{\frac{S_y}{2}} = \frac{1}{n}$ $\frac{1}{n} = \frac{14.1 \text{ kpsi}}{\frac{60 \text{ kpsi}}{2}} = \frac{2(14.1)}{60} = 0.47$ $n = \frac{1}{0.47} = 2.13$ <p>The design is safe by a factor of 2.</p>	<p><i>Step 2.</i> Using Eq. (3.31) calculate the maximum pressure (p_{\max}).</p> $p_{\max} = \frac{2F}{\pi bL}$ $= \frac{2(147,500 \text{ N})}{\pi(0.0028 \text{ m})(0.1 \text{ m})} = \frac{295,000 \text{ N}}{0.00088 \text{ m}^2}$ $= 335,400,000 \text{ N/m}^2$ $= 335.4 \text{ MPa}$ <p><i>Step 3.</i> As Poisson's ratio (ν) for the steel wheels is close to the 0.3 used to graph the principal stress equations in Fig. 3.12, assume the maximum shear stress occurs at 0.75b and is 0.3 p_{\max}. Therefore, using the value for the maximum pressure found in Step 2, the maximum shear stress (τ_{\max}) is</p> $\tau_{\max} = 0.3p_{\max} = (0.3)(335.4 \text{ MPa})$ $= 100.6 \text{ MPa}$ <p><i>Step 4.</i> Using Eq. (3.40), calculate the factor-of-safety (n) for the design as</p> $\frac{\tau_{\max}}{\frac{S_y}{2}} = \frac{1}{n}$ $\frac{1}{n} = \frac{100.6 \text{ MPa}}{\frac{420 \text{ MPa}}{2}} = \frac{2(100.6)}{420} = 0.48$ $n = \frac{1}{0.48} = 2.09$ <p>The design is safe by a factor of 2.</p>

3.4 ROTATIONAL LOADING

Rotational loading occurs when a machine element, such as a flywheel, sawblade, or turbine is spinning about a stationary axis at very high speed. Depending on the complexity of the machine element, the stresses developed must be analyzed to determine if the design is safe. It is appropriate here in Chap. 3 to limit the discussion to the basic rotating machine element: the thin solid disk. Other types of rotating machine elements, such as flywheels, will be discussed in a later chapter.

The geometry of a thin rotating disk is shown in Fig. 3.13,

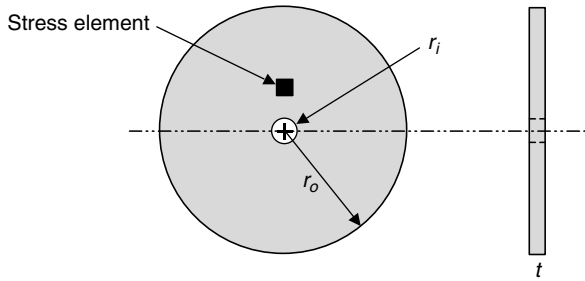

FIGURE 3.13 Thin rotating disk.

where r_o = outside radius
 r_i = inside radius
 t = thickness of disk

For the disk to be treated as *thin*, the outside radius (r_o) should be at least 25 times greater than the thickness (t). Also, it is assumed that the disk is a constant thickness (t) and the inside radius (r_i) is very small compared to the outside radius (r_o).

The rotational loading develops both a tangential stress (σ_t) and a radial stress (σ_r). These two stresses form a biaxial stress element, shown in Fig. 3.14.

As this is a biaxial stress element, the shear stress (τ_{xy}) is zero; however, there will be a maximum shear stress (τ_{max}) that is determined either mathematically or using Mohr's circle.

The tangential stress (σ_t) is given in Eq. (3.41),

$$\sigma_t = \sigma_o \frac{3 + \nu}{8} \left(1 + \frac{r_i^2}{r_o^2} + \frac{r_i^2}{r^2} - \frac{1 + 3\nu}{3 + \nu} \frac{r^2}{r_o^2} \right) \tag{3.41}$$

and the radial stress (σ_r) is given in Eq. (3.42).

$$\sigma_r = \sigma_o \frac{3 + \nu}{8} \left(1 + \frac{r_i^2}{r_o^2} - \frac{r_i^2}{r^2} - \frac{r^2}{r_o^2} \right) \tag{3.42}$$

where (ν) is Poisson's ratio and using the quantity labeled (σ_o), which has units of stress, makes these two equations more compact and mathematically manageable, where

$$\sigma_o = \rho \omega^2 r_o^2 \tag{3.43}$$

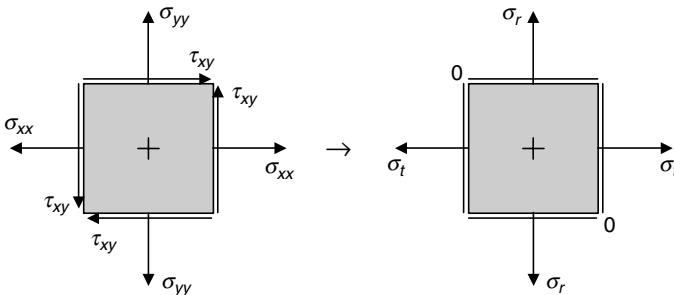

FIGURE 3.14 Biaxial stress element.

where (ρ) is the density of the disk in (slugs/ft³) or (kg/m³) and (ω) is the angular velocity of the disk in (rad/s).

Notice that the thickness (t) is not in any of these equations, as no variation is allowed perpendicular to the plane of rotation.

The tangential stress (σ_t) is a maximum at the inside radius (r_i) of the disk, given in Eq. (3.44) as

$$\sigma_t^{\max} = \sigma_o \frac{3 + \nu}{4} \left(1 + \frac{1 - \nu}{3 + \nu} \frac{r_i^2}{r_o^2} \right) \quad (3.44)$$

where the radial stress (σ_r) is zero.

The radial stress (σ_r) is a maximum at a radius ($\sqrt{r_i r_o}$), given in Eq. (3.45) as

$$\sigma_r^{\max} = \sigma_o \frac{3 + \nu}{8} \left(1 + \frac{r_i}{r_o} \right)^2 \quad (3.45)$$

where the tangential stress (σ_t) is given by Eq. (3.46) as

$$\sigma_t^{\sqrt{r_i r_o}} = \sigma_o \frac{3 + \nu}{8} \left(1 + 2 \frac{1 - \nu}{3 + \nu} \frac{r_i}{r_o} + \frac{r_i^2}{r_o^2} \right) \quad (3.46)$$

As these two stresses are both positive, and are the principal stresses (σ_1) and (σ_2), and as rotating disks are usually made of ductile materials, the distortion-energy theory will be the most accurate predictor of whether the design is safe. Therefore, the factor-of-safety for a rotating thin disk is given by Eq. (3.47) as

$$\frac{(\sigma_1^2 + \sigma_2^2 - \sigma_1 \sigma_2)^{1/2}}{S_y} = \frac{1}{n} \quad (3.47)$$

where (S_y) is the yield strength of the material.

However, for a stress element at the inside radius (r_i), the principal stress (σ_1) will be the maximum tangential stress (σ_t^{\max}) and the principal stress (σ_2) will be the radial stress (σ_r) that is zero at the inside radius, making this a uniaxial stress element, and so any of the theories for ductile materials would apply.

Consider the following example to conclude this section.

U.S. Customary	SI/Metric
<p>Example 1. Determine whether the design of a thin high-speed saw blade is safe, where</p> <p>$\omega = 1,000$ rpm $r_o = 3$ ft = 36 in $r_i = 1$ in $t = 0.25$ in $\rho = 15.2$ slug/ft³ (steel) $S_y = 50$ kpsi (steel) $\nu = 0.3$ (steel)</p>	<p>Example 1. Determine whether the design of a thin high-speed saw blade is safe, where</p> <p>$\omega = 1,000$ rpm $r_o = 1$ m $r_i = 2.5$ cm = 0.025 m $t = 0.6$ cm = 0.006 m $\rho = 7,850$ kg/m³ (steel) $S_y = 350$ MPa (steel) $\nu = 0.3$ (steel)</p>

U.S. Customary	SI/Metric
<p>solution</p> <p><i>Step 1.</i> Convert the units on the speed of rotation (ω) from rpm to (rad/s)</p> $\begin{aligned}\omega &= 1,000 \frac{\text{rev}}{\text{min}} \times \frac{2\pi \text{ rad}}{\text{rev}} \times \frac{1 \text{ min}}{60 \text{ s}} \\ &= \frac{(1,000)(2\pi)}{60} \frac{\text{rad}}{\text{s}} \\ &= 105 \text{ (rad/s)}\end{aligned}$ <p><i>Step 2.</i> Using Eq. (3.43) calculate the quantity (σ_o) as</p> $\begin{aligned}\sigma_o &= \rho\omega^2 r_o^2 \\ &= \left(15.2 \frac{\text{slug}}{\text{ft}^3}\right) \left(105 \frac{\text{rad}}{\text{s}^2}\right)^2 (3 \text{ ft})^2 \\ &= \left[(15.2)(105)^2(3)^2\right] \frac{\text{slug} \cdot \text{ft}}{\text{s}^2} \frac{\text{ft}}{\text{ft}^3} \\ &= 1,508,220 \frac{\text{lb}}{\text{ft}^2} = 9,975 \text{ lb/in}^2 \\ &= 10.0 \text{ kpsi}\end{aligned}$ <p><i>Step 3.</i> Calculate the maximum tangential stress (σ_t) at the inside radius (r_i), where the radial (σ_r) is zero, using Eq. (3.44).</p> $\begin{aligned}\sigma_t^{\text{max}} &= \sigma_o \frac{3+\nu}{4} \left(1 + \frac{1-\nu}{3+\nu} \frac{r_i^2}{r_o^2}\right) \\ &= (10 \text{ kpsi}) \frac{3+0.3}{4} \\ &\quad \times \left(1 + \frac{1-0.3}{3+0.3} \frac{(1 \text{ in})^2}{(36 \text{ in})^2}\right) \\ &= (10 \text{ kpsi}) \frac{3.3}{4} \\ &\quad \times \left(1 + \frac{0.7}{3.3} \frac{1}{1296}\right) \\ &= (10 \text{ kpsi})(0.825) \\ &\quad \times (1 + 0.00016) \\ &= 8.25 \text{ kpsi}\end{aligned}$	<p>solution</p> <p><i>Step 1.</i> Convert the units on the speed of rotation (ω) from rpm to (rad/s)</p> $\begin{aligned}\omega &= 1,000 \frac{\text{rev}}{\text{min}} \times \frac{2\pi \text{ rad}}{\text{rev}} \times \frac{1 \text{ min}}{60 \text{ s}} \\ &= \frac{(1,000)(2\pi)}{60} \frac{\text{rad}}{\text{s}} \\ &= 105 \text{ (rad/s)}\end{aligned}$ <p><i>Step 2.</i> Using Eq. (3.43) calculate the quantity (σ_o) as</p> $\begin{aligned}\sigma_o &= \rho\omega^2 r_o^2 \\ &= \left(7,850 \frac{\text{kg}}{\text{m}^3}\right) \left(105 \frac{\text{rad}}{\text{s}^2}\right)^2 (1 \text{ m})^2 \\ &= \left[(7,850)(105)^2(1)^2\right] \frac{\text{kg} \cdot \text{m}}{\text{s}^2} \frac{\text{m}}{\text{m}^3} \\ &= 86,546,250 \frac{\text{N}}{\text{m}^2} \\ &= 86.5 \text{ MPa}\end{aligned}$ <p><i>Step 3.</i> Calculate the maximum tangential stress (σ_t) at the inside radius (r_i), where the radial (σ_r) is zero, using Eq. (3.44).</p> $\begin{aligned}\sigma_t^{\text{max}} &= \sigma_o \frac{3+\nu}{4} \left(1 + \frac{1-\nu}{3+\nu} \frac{r_i^2}{r_o^2}\right) \\ &= (86.5 \text{ MPa}) \frac{3+0.3}{4} \\ &\quad \times \left(1 + \frac{1-0.3}{3+0.3} \frac{(0.025 \text{ m})^2}{(1 \text{ m})^2}\right) \\ &= (86.5 \text{ MPa}) \frac{3.3}{4} \\ &\quad \times \left(1 + \frac{0.7}{3.3} \frac{0.000625}{1}\right) \\ &= (86.5 \text{ MPa})(0.825) \\ &\quad \times (1 + 0.00013) \\ &= 71.4 \text{ MPa}\end{aligned}$

U.S. Customary	SI/Metric
<p><i>Step 4.</i> Calculate the maximum radial stress (σ_r) and the tangential stress (σ_t) at the radius ($\sqrt{r_i r_o}$), using Eqs. (3.45) and (3.46).</p> $\begin{aligned}\sigma_r^{\max} &= \sigma_o \frac{3+\nu}{8} \left(1 + \frac{r_i}{r_o}\right)^2 \\ &= (10 \text{ kpsi}) \frac{3+0.3}{8} \left(1 + \frac{1 \text{ in}}{36 \text{ in}}\right)^2 \\ &= (10 \text{ kpsi}) \frac{3.3}{8} (1 + 0.0278)^2 \\ &= (10 \text{ kpsi})(0.4125)(1.0278)^2 \\ &= 4.36 \text{ kpsi}\end{aligned}$ $\begin{aligned}\sigma_t^{\sqrt{r_i r_o}} &= \sigma_o \frac{3+\nu}{8} \left(1 + 2\frac{1-\nu}{3+\nu} \frac{r_i}{r_o} + \frac{r_i^2}{r_o^2}\right) \\ &= (10 \text{ kpsi}) \frac{3+0.3}{8} \\ &\quad \times \left(1 + 2\frac{1-0.3}{3+0.3} \frac{1 \text{ in}}{36 \text{ in}} + \frac{(1 \text{ in})^2}{(36 \text{ in})^2}\right) \\ &= (10 \text{ kpsi}) \frac{3.3}{8} \\ &\quad \times \left(1 + 2\frac{0.7}{3.3} \frac{1}{36} + \frac{1}{1296}\right) \\ &= (10 \text{ kpsi})(0.4125) \\ &\quad \times (1 + 0.012 + 0.00077) \\ &= 4.18 \text{ kpsi}\end{aligned}$ <p><i>Step 5.</i> Using Eq. (3.47), calculate the factor-of-safety (n) at the inside radius (r_i) where the principal stress (σ_1) is the maximum tangential stress found in Step 3 and the principal stress (σ_2) is zero.</p> $\begin{aligned}\frac{(\sigma_1^2 + \sigma_2^2 - \sigma_1 \sigma_2)^{1/2}}{S_y} &= \frac{1}{n} \\ \frac{((8.25)^2 + (0)^2 - (8.25)(0))^{1/2}}{50} &= \frac{1}{n} \\ \frac{((8.25)^2)^{1/2}}{50} &= \frac{8.25}{50} = \frac{1}{n} \\ n &= \frac{50}{8.25} = 6.1\end{aligned}$ <p>Clearly the design is safe.</p>	<p><i>Step 4.</i> Calculate the maximum radial stress (σ_r) and the tangential stress (σ_t) at the radius ($\sqrt{r_i r_o}$), using Eqs. (3.45) and (3.46).</p> $\begin{aligned}\sigma_r^{\max} &= \sigma_o \frac{3+\nu}{8} \left(1 + \frac{r_i}{r_o}\right)^2 \\ &= (86.5 \text{ MPa}) \frac{3+0.3}{8} \left(1 + \frac{0.025 \text{ m}}{1 \text{ m}}\right)^2 \\ &= (86.5 \text{ MPa}) \frac{3.3}{8} (1 + 0.025)^2 \\ &= (86.5 \text{ MPa})(0.4125)(1.025)^2 \\ &= 37.5 \text{ MPa}\end{aligned}$ $\begin{aligned}\sigma_t^{\sqrt{r_i r_o}} &= \sigma_o \frac{3+\nu}{8} \left(1 + 2\frac{1-\nu}{3+\nu} \frac{r_i}{r_o} + \frac{r_i^2}{r_o^2}\right) \\ &= (86.5 \text{ MPa}) \frac{3+0.3}{8} \\ &\quad \times \left(1 + 2\frac{1-0.3}{3+0.3} \frac{0.025 \text{ m}}{1 \text{ m}} + \frac{(0.025 \text{ m})^2}{(1 \text{ m})^2}\right) \\ &= (86.5 \text{ MPa}) \frac{3.3}{8} \\ &\quad \times \left(1 + 2\frac{0.7}{3.3} \frac{0.025}{1} + \frac{0.000625}{1}\right) \\ &= (86.5 \text{ MPa})(0.4125) \\ &\quad \times (1 + 0.0106 + 0.000625) \\ &= 36.1 \text{ MPa}\end{aligned}$ <p><i>Step 5.</i> Using Eq. (3.47), calculate the factor-of-safety (n) at the inside radius (r_i) where the principal stress (σ_1) is the maximum tangential stress found in Step 3 and the principal stress (σ_2) is zero.</p> $\begin{aligned}\frac{(\sigma_1^2 + \sigma_2^2 - \sigma_1 \sigma_2)^{1/2}}{S_y} &= \frac{1}{n} \\ \frac{((71.4)^2 + (0)^2 - (71.4)(0))^{1/2}}{50} &= \frac{1}{n} \\ \frac{((71.4)^2)^{1/2}}{50} &= \frac{71.4}{350} = \frac{1}{n} \\ n &= \frac{350}{71.4} = 4.9\end{aligned}$ <p>Clearly the design is safe.</p>

U.S. Customary	SI/Metric
<p><i>Step 6.</i> Using Eq. (3.47), calculate the factor-of-safety (n) at the radial distance ($\sqrt{r_i r_o}$) where the principal stress (σ_1) is the maximum radial stress found in Step 4 and the principal stress (σ_2) is tangential stress also found in Step 4.</p> $\frac{(\sigma_1^2 + \sigma_2^2 - \sigma_1 \sigma_2)^{1/2}}{S_y} = \frac{1}{n}$ $\frac{((4.36)^2 + (4.18)^2 - (4.36)(4.18))^{1/2}}{50} = \frac{1}{n}$ $\frac{(18.26)^{1/2}}{50} = \frac{4.27}{50} = \frac{1}{n}$ $n = \frac{50}{4.27} = 11.7$ <p>Clearly the design is very safe.</p>	<p><i>Step 6.</i> Using Eq. (3.47), calculate the factor-of-safety (n) at the radial distance ($\sqrt{r_i r_o}$) where the principal stress (σ_1) is the maximum radial stress found in Step 4 and the principal stress (σ_2) is tangential stress also found in Step 4.</p> $\frac{(\sigma_1^2 + \sigma_2^2 - \sigma_1 \sigma_2)^{1/2}}{S_y} = \frac{1}{n}$ $\frac{((37.5)^2 + (36.1)^2 - (37.5)(36.1))^{1/2}}{350} = \frac{1}{n}$ $\frac{(1356)^{1/2}}{350} = \frac{36.8}{350} = \frac{1}{n}$ $n = \frac{350}{36.8} = 9.5$ <p>Clearly the design is very safe.</p>

Notice that the stress element at the inside radius (r_i) has a lower factor-of-safety than the one at the radial distance ($\sqrt{r_i r_o}$). This means it is the most important stress element in deciding whether the design is safe or not.

CHAPTER 4

COMBINED LOADINGS

4.1 INTRODUCTION

Combined loadings on machine elements are a *combination* of two or more of the fundamental and advanced loadings discussed in Chaps. 1 and 3. This includes axial loading, direct shear loading, torsion, bending, pressure loading inside thin-walled vessels and thick-walled cylinders, and press or shrink fits, contact loading between either *spheres* or cylinders, and rotational loading on thin circular disks. In actual practice, it is difficult to have more than two of these loadings acting at the same time. So in this chapter, only the most common combinations will be presented.

Table 4.1 is a summary of the normal stress (σ) and the shear stress (τ) produced by fundamental loadings presented in Chap. 1.

TABLE 4.1 Summary of the Fundamental Loadings

Loading	Normal stress (σ)	Shear stress (τ)
Axial	$\sigma = \frac{P}{A}$	—
Thermal	$\sigma_T = E\alpha (\Delta T)$	—
Direct shear	—	$\tau = \frac{V}{A}$
Torsion	—	$\tau = \frac{Tr}{J}$
Bending	$\sigma = \frac{My}{I}$	$\tau = \frac{VQ}{Ib}$

Table 4.2 is a summary of the normal (σ) stresses produced by pressure loadings and presented in Chap. 3 on advanced loadings.

The equations from Sec. 3.1.3 on press or shrink fits are not included in Table 4.2 as what is produced is an interface pressure (p), which becomes an internal pressure on the collar and an external pressure on the shaft, and this type of loading on thick-walled cylinders is covered in Sec. 3.1.2.

At this point, the concept of a plane stress element needs to be introduced, along with the standard nomenclature and conventions for the two types of stress, normal (σ) and shear (τ), summarized in Tables 4.1 and 4.2.

Plane Stress Element. The geometry of a differential plane stress element is shown in Fig. 4.1, where the dimensions (Δx) and (Δy) are such that the stresses, whether normal (σ) or shear (τ), can be considered constant over the cross-sectional areas of the edges

TABLE 4.2 Summary of the Pressure Loadings

Element	Normal stress (σ)	Shear stress (τ)
Thin-wall sphere	$\sigma_{\text{sph}} = \frac{p_i r_m}{2t}$	—
Thin-wall cylinder:		
Axial	$\sigma_{\text{axial}} = \frac{p_i r_m}{2t}$	—
Hoop	$\sigma_{\text{hoop}} = \frac{p_i r_m}{t}$	—
Thick-wall cylinder: ($p_o = 0$)		
Tangential	$\sigma_t = \frac{p_i r_i^2}{r_o^2 - r_i^2} \left[1 + \left(\frac{r_o}{r} \right)^2 \right]$	—
Radial	$\sigma_r = \frac{p_i r_i^2}{r_o^2 - r_i^2} \left[1 - \left(\frac{r_o}{r} \right)^2 \right]$	—
Axial	$\sigma_a = \frac{p_i r_i^2}{r_o^2 - r_i^2}$	—

of the element, meaning $(\Delta x \Delta z)$ or $(\Delta y \Delta z)$. The dimension (Δz) is very much smaller than either (Δx) or (Δy) so that it can be assumed that there is no variation in the stresses perpendicular to the plane of the stress element, meaning in the z direction.

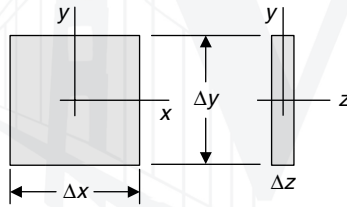

FIGURE 4.1 Geometry of a plane stress element.

The standard nomenclature and sign conventions for both normal stress (σ) and shear stress (τ) for a plane stress element are shown in Fig. 4.2, where positive normal stress (σ) is directed outward from the element. Therefore, pressure (p_i) is a negative stress.

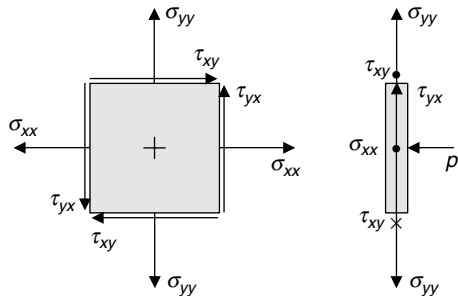

FIGURE 4.2 Plane stress element.

The first subscript on the stresses shown in Fig. 4.2 indicates the direction of the stress, and the second subscript indicates the direction of the perpendicular to the surface area on which the stress acts. For the shear stresses shown, (τ_{xy}) and (τ_{yx}) are interchangeable, so only (τ_{xy}) will be used in the remainder of this book. As mentioned earlier, and as shown in Fig. 4.2, the internal pressure (p_i) acts perpendicular to the plane stress element; however, it is directed toward the surface of the element and so it is considered a negative normal stress. More about the effect of an internal pressure on the overall stress distribution on an element is presented in Chap. 5.

Although Fig. 4.2 shows the worst case scenario for a stress element, and as mentioned earlier a very rare occurrence in actual engineering practice, there are three special plane stress elements. These three elements are called uniaxial stress element, biaxial stress element, and pure shear stress element. These three elements have special significance that will be discussed in Chap. 5.

Uniaxial Stress Element. For the fundamental loadings of axial, thermal, and bending, a uniaxial stress element is produced and shown in Fig. 4.3,

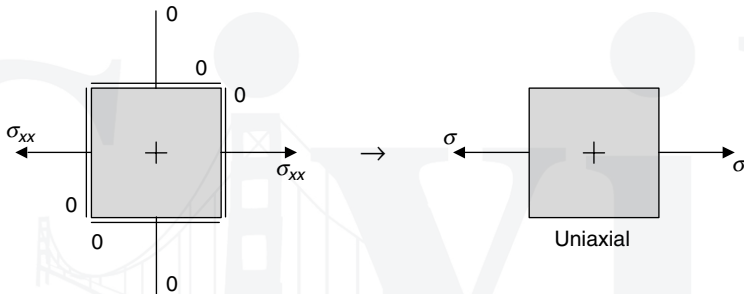

FIGURE 4.3 Uniaxial stress element.

where there is only normal stress (σ) along the axis of interest; and the other stresses, the normal stress (σ_{yy}) and the four shear stresses (τ_{xy}) , are zero.

Biaxial Stress Element. For the pressure loadings on thin-walled vessels, both spherical and cylindrical, and thick-walled cylinders, a biaxial stress element is produced and shown in Fig. 4.4,

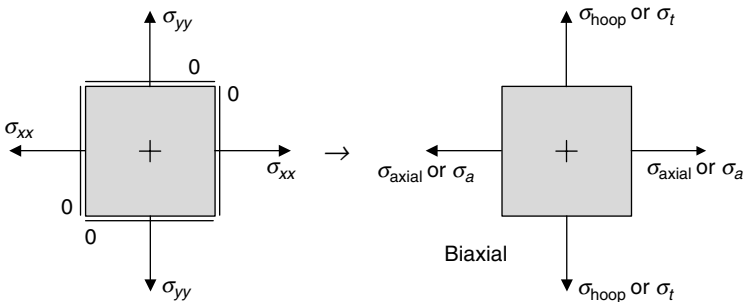

FIGURE 4.4 Biaxial stress element.

where there are the normal stresses (σ_{axial}) or (σ_a) in the x -direction, along the axis of interest, and the normal stresses (σ_{hoop}) or (σ_t) in the y -direction, perpendicular to the axis of

interest. As with the uniaxial stress element, the four shear stresses (τ_{xy}) are zero. In the case of a thin-walled spherical vessel under internal pressure, the normal stresses (σ_{sph}) in both directions are equal. However, for either thin-walled or thick-walled cylinders, the normal stresses will be different, and in fact the hoop or tangential stress will be twice the axial stress.

The radial stress (σ_r) in a thick-walled cylinder acts perpendicular to the plane stress element, in the z -direction, similar to that for an internal pressure (p_i), so it cannot be depicted in Fig. 4.4.

Pure Shear Stress Element. For the fundamental loadings of direct shear, torsion, and shear due to bending, a pure shear stress element is produced and shown in Fig. 4.5,

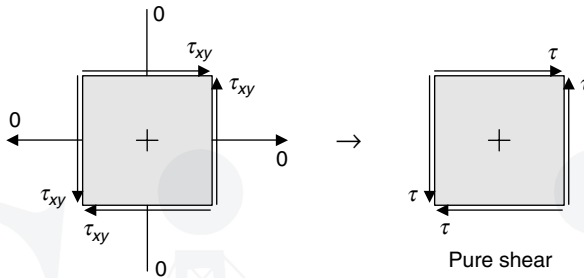

FIGURE 4.5 Pure shear stress element.

where the normal stresses (σ_{xx}) and (σ_{yy}) are zero and the four shear stresses (τ_{xy}) are equal and denoted by (τ). Recall that the directions of the shear stresses shown in Fig. 4.5 are such that a square stress element will deform to a parallelogram under load, where the change in the right angle is the shear strain (γ), measured in radians.

Also, for bending, Table 4.1 shows a normal stress (σ) and a shear stress (τ). Normally, a beam element will have both stresses, and therefore, yield a general plane stress element like that shown in Fig. 4.2. However, usually what is of interest are maximum values, so when the normal stress is maximum the shear stress is zero, and when the shear stress is maximum, the normal stress is zero. Therefore, where the normal stress is maximum, uniaxial stress element exists, and where the shear stress is maximum, pure shear stress element exists.

Let us now consider several combinations of loadings from Tables 4.1 and 4.2 that will produce general stress elements.

4.2 AXIAL AND TORSION

The first combination of loadings to be considered is axial and torsion. This is a very common loading for shafts carrying both a torque (T) and an end load (P), as shown in Fig. 4.6.

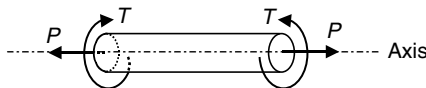

FIGURE 4.6 Axial and torsion loading.

Stress Element. The general stress element shown in Fig. 4.2 becomes the stress element shown in Fig. 4.7, where the normal stress (σ_{xx}) is the axial stress, the normal stress (σ_{yy}) is zero, and the shear stress (τ_{xy}) is the shear stress due to torsion.

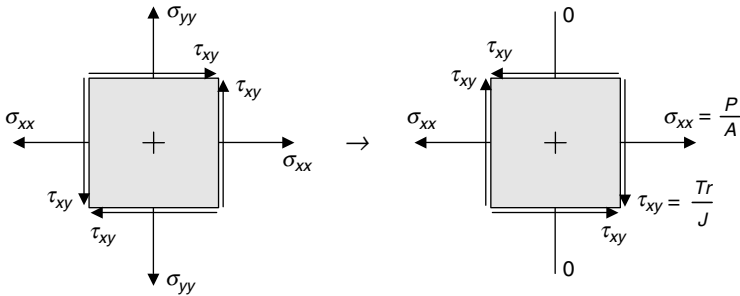

FIGURE 4.7 Stress element for axial and torsion.

The shear stress due to torsion (τ_{xy}) is shown downward on the right edge of the stress element because the torque (T) shown in Fig. 4.6 is counterclockwise looking in from the right side to the left side.

Aside. The significance of this change in the direction of the shear stresses in Fig. 4.7 will become apparent in Chap. 5. Notice that the directions of the other three shear stresses changed as well; again, as mentioned several times, a square element must deform to a parallelogram. However, more importantly, there are also equilibrium considerations to satisfy, both with respect to forces and moments. For example, if each of the four shear stresses (τ) on the pure shear stress element shown in Fig. 4.5 are multiplied by the area (A) of the edge of the element over which each acts, a force with a magnitude ($\tau \times A$) will result along each edge in the same direction as the shear stresses. This stress element actually becomes a free-body diagram that is shown in Fig. 4.8.

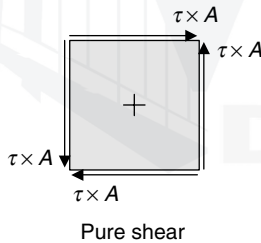

FIGURE 4.8 Free-body of pure shear stress element.

Because of the directions shown, two of the forces balance in the x -direction, two of the forces balance in the y -direction, and pairs of the forces balance clockwise and counterclockwise if moments are taken about the center of the element. So when the direction of one of the four shear stresses is known, the other three shear stresses must be in such a direction that this equilibrium condition is satisfied.

Location of Maximum Stress Elements. The plane stress element in Fig. 4.7 is valid for any element in the shaft. The axial stress (σ_{xx}) is constant over the cross section; however, the shear stress (τ_{xy}) varies with the radius (r) measured from the center of the shaft. Usually, what is of greatest importance are the maximum values of the stresses; so for this particular loading, elements on the surface of the shaft at a radius (R) are the elements of greatest interest. For example, in Fig. 4.9 the darkened rectangle is just one of the infinite number of plane stress elements that have the maximum values of stress acting on them.

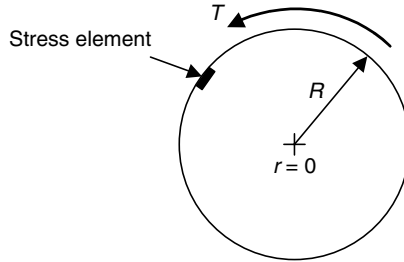

FIGURE 4.9 Element for maximum stress.

Figure 4.9 is a view down the axis of the shaft, showing the torque (T) acting counter-clockwise. The darkened rectangle is at a radius (R) and the dimension of the element in the radial direction is assumed to be much smaller than the other two dimensions, which is the primary requirement of plane stress analysis.

For many of the other load combinations, locating the plane stress element of greatest interest will be more difficult, and in fact there may be several elements from which to choose a worse case scenario for your design.

Although it will be a review on the stress equations, consider the following example to show how combinations of loadings will result in actual quantitative information.

U.S. Customary	SI/Metric
<p>Example 1. Determine the maximum stresses due to a combination of axial and torsion loads on a solid shaft, where</p> $P = 10 \text{ kip} = 10,000 \text{ lb}$ $T = 5,000 \text{ ft} \cdot \text{lb} = 60,000 \text{ in} \cdot \text{lb}$ $D = 4.0 \text{ in} = 2 R$ <p>solution</p> <p><i>Step 1.</i> Calculate the cross-sectional area (A) of the shaft.</p> $A = \pi R^2 = \pi (2.0 \text{ in})^2 = 12.57 \text{ in}^2$ <p><i>Step 2.</i> Substitute this cross-sectional area and the force (P) in the equation for axial stress to give</p> $\sigma = \frac{P}{A} = \frac{10,000 \text{ lb}}{12.57 \text{ in}^2}$ $= 796 \text{ lb/in}^2 = 0.8 \text{ kpsi}$ <p><i>Step 3.</i> Calculate the polar moment of inertia (J) for the shaft.</p> $J = \frac{1}{2} \pi R^4 = \frac{1}{2} \pi (2.0 \text{ in})^4$ $= 25.13 \text{ in}^4$	<p>Example 1. Determine the maximum stresses due to a combination of axial and torsion loads on a solid shaft, where</p> $P = 45 \text{ kN} = 45,000 \text{ N}$ $T = 7,500 \text{ N} \cdot \text{m}$ $D = 10.0 \text{ cm} = 0.1 \text{ m} = 2 R$ <p>solution</p> <p><i>Step 1.</i> Calculate the cross-sectional area (A) of the shaft.</p> $A = \pi R^2 = \pi (0.05 \text{ m})^2 = 0.008 \text{ m}^2$ <p><i>Step 2.</i> Substitute this cross-sectional area and the force (P) in the equation for axial stress to give</p> $\sigma = \frac{P}{A} = \frac{45,000 \text{ N}}{0.008 \text{ m}^2}$ $= 5,625,000 \text{ N/m}^2 = 5.6 \text{ MPa}$ <p><i>Step 3.</i> Calculate the polar moment of inertia (J) for the shaft.</p> $J = \frac{1}{2} \pi R^4 = \frac{1}{2} \pi (0.05 \text{ m})^4$ $= 0.0000098 \text{ m}^4$

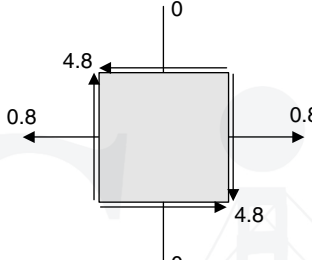
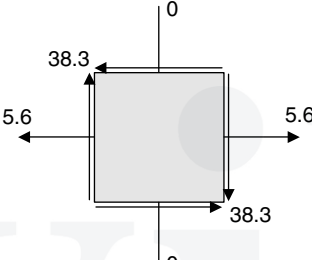
U.S. Customary	SI/Metric
<p><i>Step 4.</i> Substitute this polar moment of inertia (J), the radius (R), and the torque (T) in the equation for maximum shear stress due to torsion to give</p> $\tau_{\max} = \frac{TR}{J} = \frac{(60,000 \text{ in} \cdot \text{lb})(2.0 \text{ in})}{25.13 \text{ in}^4}$ $= 4,775 \text{ lb/in}^2 = 4.8 \text{ kpsi}$ <p><i>Step 5.</i> Display the answers for the axial stress (σ) and maximum shear stress (τ_{\max}), in kpsi, found in steps 2 and 4 on a plane stress element.</p>  <p>The above diagram will be a starting point for the discussions in Chap. 5.</p>	<p><i>Step 4.</i> Substitute this polar moment of inertia (J), the radius (R), and the torque (T) in the equation for maximum shear stress due to torsion to give</p> $\tau_{\max} = \frac{TR}{J} = \frac{(7,500 \text{ N} \cdot \text{m})(0.05 \text{ m})}{0.0000098 \text{ m}^4}$ $= 38,270,000 \text{ N/m}^2 = 38.3 \text{ MPa}$ <p><i>Step 5.</i> Display the answers for the axial stress (σ) and maximum shear stress (τ_{\max}), in MPa, found in steps 2 and 4 on a plane stress element.</p>  <p>The above diagram will be a starting point for the discussions in Chap. 5.</p>

Consider another combination of fundamental loads from those in Table 4.1, axial and bending.

4.3 AXIAL AND BENDING

The second combination of loadings to be considered is axial and bending. This is a somewhat common loading for structural elements constrained axially. Shown in Fig. 4.10 is a simply-supported beam with a concentrated force (F) at its midpoint, and a compressive axial load (P).

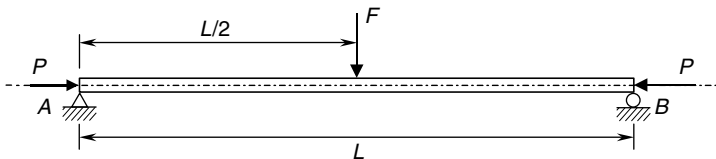

FIGURE 4.10 Axial and bending loads.

In this section, the bending moment (M) and shear force (V) are assumed to be known for whatever beam and loading is of interest. (See Chap. 2 on *Beams*.)

Stress Element. The general stress element shown in Fig. 4.2 becomes the stress element shown in Fig. 4.11, where the normal stress (σ_{xx}) is a combination of the axial stress and bending stress, the normal stress (σ_{yy}) is zero, and the shear stress (τ_{xy}) is the shear stress due to bending.

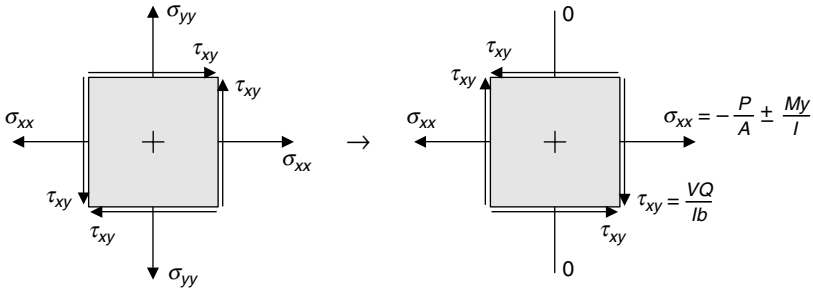

FIGURE 4.11 Stress element for axial and bending loads.

As shown in Fig. 4.11, the normal stress (σ_{xx}) has two terms, one due to the compressive axial load (P) that is constant across the cross section of the beam and is always negative, and the other term is due to the bending moment (M) in the beam and will be positive on one side of the neutral axis and negative on the other side. It will always be zero at the neutral axis. For the particular loading shown in Fig. 4.10, the top of the beam is in compression and the bottom is in tension.

The shear stress due to bending (τ_{xy}) is shown downward on the right edge of the stress element because the shear force (V) will be downward at the right side of the cross section of the beam. This shear stress due to bending will be maximum at the neutral axis and zero at the top and bottom of the beam.

As a consequence of what has just been said about the normal and shear stresses, there are actually two stress elements to consider. One is a stress element at the top or the bottom of the beam where the bending stress is maximum and the shear stress zero; and the other is a stress element at the neutral axis where the shear stress is maximum and the bending stress zero. The axial stress will be the same on both these elements. Figure 4.12 shows an element at the top of the beam and the element at the neutral axis.

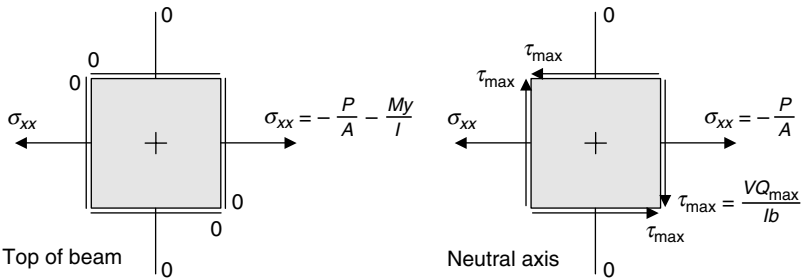

FIGURE 4.12 Special elements for axial and bending loads.

Notice that the element at the top of the beam, as well as the one that would be at the bottom, are uniaxial stress elements. The element at the neutral axis is a general stress

element, but with the normal stress (σ_{yy}) equal to zero. Keep in mind that it is very rare to have a completely general stress element in actual engineering practice.

Again, although it will be a review on the stress equations, consider the following examples to show how this combination of loadings result in quantitative information.

U.S. Customary	SI/Metric
<p>Example 2. Determine the stresses at the top of a rectangular beam, like the one in Fig. 4.10, subjected to a combination of compressive axial and bending loads, where</p> $P = 4 \text{ kip} = 6,000 \text{ lb}$ $M = 8,000 \text{ ft} \cdot \text{lb} = 96,000 \text{ in} \cdot \text{lb}$ $V = 10,000 \text{ lb}$ $h = 12.0 \text{ in}$ $b = 2.0 \text{ in}$ <p>solution</p> <p><i>Step 1.</i> Calculate the cross-sectional area (A) of the beam.</p> $A = bh = (2.0 \text{ in})(12.0 \text{ in}) = 24.0 \text{ in}^2$ <p><i>Step 2.</i> Substitute this cross-sectional area and the force (P) in the equation for compressive axial stress to give</p> $\sigma = -\frac{P}{A} = -\frac{6,000 \text{ lb}}{24.0 \text{ in}^2}$ $= -250 \text{ lb/in}^2 = -0.25 \text{ kpsi}$ <p><i>Step 3.</i> Calculate the moment of inertia (I) for the beam.</p> $I = \frac{1}{12} bh^3 = \frac{1}{12} (2.0 \text{ in})(12.0 \text{ in})^3$ $= 288 \text{ in}^4$ <p><i>Step 4.</i> Substitute this moment of inertia (I), the distance (y) to the top of the beam, and the bending moment (M) in the equation for maximum negative normal stress due to bending to give</p> $\sigma_{\max} = -\frac{M y_{\text{top}}}{I}$ $= -\frac{(96,000 \text{ in} \cdot \text{lb})(6.0 \text{ in})}{288 \text{ in}^4}$ $= -2,000 \text{ lb/in}^2 = -2 \text{ kpsi}$ <p><i>Step 5.</i> Combine the two compressive stresses found in steps 2 and 4 to give a maximum normal stress at the top (σ_{top}).</p>	<p>Example 2. Determine the stresses at the top of a rectangular beam, like the one in Fig. 4.10, subjected to a combination of compressive axial and bending loads, where</p> $P = 18 \text{ kN} = 18,000 \text{ N}$ $M = 12 \text{ kN} \cdot \text{m} = 12,000 \text{ N} \cdot \text{m}$ $V = 45 \text{ kN} = 45,000 \text{ N}$ $h = 30.0 \text{ cm} = 0.3 \text{ m}$ $b = 5.0 \text{ cm} = 0.05 \text{ m}$ <p>solution</p> <p><i>Step 1.</i> Calculate the cross-sectional area (A) of the beam.</p> $A = bh = (0.05 \text{ m})(0.3 \text{ m}) = 0.015 \text{ m}^2$ <p><i>Step 2.</i> Substitute this cross-sectional area and the force (P) in the equation for compressive axial stress to give</p> $\sigma = -\frac{P}{A} = -\frac{18,000 \text{ N}}{0.015 \text{ m}^2}$ $= -1,200,000 \text{ N/m}^2 = -1.2 \text{ MPa}$ <p><i>Step 3.</i> Calculate the moment of inertia (I) for the beam.</p> $I = \frac{1}{12} bh^3 = \frac{1}{12} (0.05 \text{ m})(0.3 \text{ m})^3$ $= 0.0001125 \text{ m}^4$ <p><i>Step 4.</i> Substitute this moment of inertia (I), the distance (y) to the top of the beam, and the bending moment (M) in the equation for maximum negative normal stress due to bending to give</p> $\sigma_{\max} = -\frac{M y_{\max}}{I}$ $= -\frac{(12,000 \text{ N} \cdot \text{m})(0.15 \text{ m})}{0.0001125 \text{ m}^4}$ $= -16,000,000 \text{ N/m}^2 = -16 \text{ MPa}$ <p><i>Step 5.</i> Combine the two compressive stresses found in steps 2 and 4 to give a maximum normal stress at the top (σ_{top}).</p>

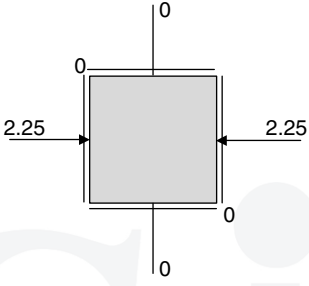
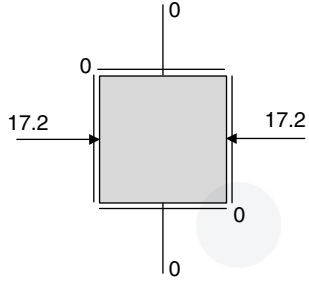
U.S. Customary	SI/Metric
$\begin{aligned}\sigma_{top} &= \sigma_{axial} + \sigma_{max} \\ &= (-0.25 \text{ kpsi}) + (-2.0 \text{ kpsi}) \\ &= -2.25 \text{ kpsi}\end{aligned}$	$\begin{aligned}\sigma_{top} &= \sigma_{axial} + \sigma_{max} \\ &= (-1.2 \text{ MPa}) + (-16.0 \text{ MPa}) \\ &= -17.2 \text{ MPa}\end{aligned}$
<p><i>Step 6.</i> Display the answer for the maximum normal stress at the top (σ_{top}) found in step 5, in kpsi, on a uniaxial stress element.</p>	<p><i>Step 6.</i> Display the answer for the maximum normal stress at the top (σ_{top}) found in step 5, in MPa, on a uniaxial stress element.</p>
	
<p>Negative signs are not used in the above diagram as the directions of the arrows indicate compression. As stated at the end of Example 1, this diagram will be a starting point for the discussions in Chap. 5.</p>	<p>Negative signs are not used in the above diagram as the directions of the arrows indicate compression. As stated at the end of Example 1, this diagram will be a starting point for the discussions in Chap. 5.</p>

Location of Maximum Stress Elements. The plane stress elements in Fig. 4.12 are for two special locations in the cross section of the beam. As already mentioned, one part of the normal stress (σ_{xx}) is constant and the other part varies over the cross section. The shear stress (τ_{xy}) due to bending also varies over the cross section, but opposite to the normal stress due to bending. Example 2 considered one of the two maximum stress elements, the element at the top of the beam, whereas Example 3 will consider the element at the neutral axis. There is actually a third stress element of interest, one at the bottom of the beam, where the normal stress due to the axial load is still compressive but the normal stress due to bending is tensile.

In Fig. 4.13, the rectangular cross section of Example 1 is shown with the three darkened rectangles locating these three special stress elements.

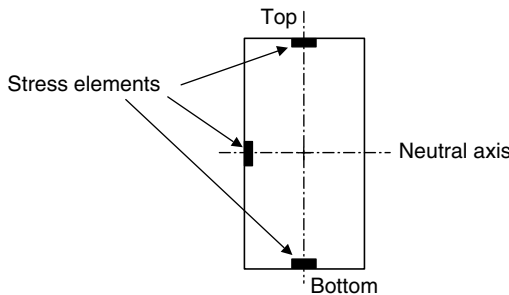
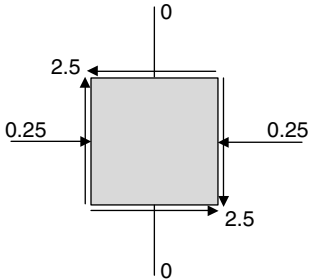
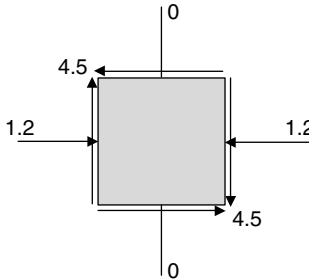

FIGURE 4.13 Elements for maximum stress.

Consider the following example concerning the stress element at the neutral axis.

U.S. Customary	SI/Metric
<p>Example 3. Determine the stresses on the element at the neutral axis of the rectangular beam of Example 2, where</p> $P = 4 \text{ kip} = 6,000 \text{ lb}$ $M = 8,000 \text{ ft} \cdot \text{lb} = 96,000 \text{ in} \cdot \text{lb}$ $V = 10,000 \text{ lb}$ $h = 12.0 \text{ in}$ $b = 2.0 \text{ in}$ <p>solution</p> <p><i>Step 1.</i> The cross-sectional area (A) of the beam was found in Example 2 to be</p> $A = bh = (2.0 \text{ in})(12.0 \text{ in}) = 24.0 \text{ in}^2$ <p><i>Step 2.</i> Using this area (A) and the axial force (P), the compressive stress was found in Example 2 to be</p> $\sigma = -\frac{P}{A} = -\frac{6,000 \text{ lb}}{24.0 \text{ in}^2}$ $= -250 \text{ lb/in}^2 = -0.25 \text{ kpsi}$ <p><i>Step 3.</i> The moment of inertia (I) of the beam was found in Example 2 to be</p> $I = \frac{1}{12}bh^3 = \frac{1}{12}(2.0 \text{ in})(12.0 \text{ in})^3$ $= 288 \text{ in}^4$ <p><i>Step 4.</i> The maximum first moment (Q_{\max}) is needed, and is found for a rectangle using Eq. (1.41) as</p> $Q_{\max} = \frac{1}{8}bh^2 = \frac{1}{8}(2.0 \text{ in})(12.0 \text{ in})^2$ $= 36 \text{ in}^3$ <p><i>Step 5.</i> Substitute the shear force (V), the maximum first moment (Q_{\max}), the moment of inertia (I), and the width (b) in Eq. (1.39) for the shear stress due to bending to give</p> $\tau_{\max} = \frac{VQ_{\max}}{Ib}$ $= \frac{(10,000 \text{ lb})(36 \text{ in}^3)}{(288 \text{ in}^4)(2 \text{ in})}$ $= \frac{360,000 \text{ lb} \cdot \text{in}^3}{576 \text{ in}^5}$ $= 2,500 \text{ lb/in}^2 = 2.5 \text{ kpsi}$	<p>Example 3. Determine the stresses on the element at the neutral axis of the rectangular beam of Example 2, where</p> $P = 18 \text{ kN} = 18,000 \text{ N}$ $M = 12 \text{ kN} \cdot \text{m} = 12,000 \text{ N} \cdot \text{m}$ $V = 45 \text{ kN} = 45,000 \text{ N}$ $h = 30.0 \text{ cm} = 0.3 \text{ m}$ $b = 5.0 \text{ cm} = 0.05 \text{ m}$ <p>solution</p> <p><i>Step 1.</i> The cross-sectional area (A) of the beam was found in Example 2 to be</p> $A = bh = (0.05 \text{ m})(0.3 \text{ m}) = 0.015 \text{ m}^2$ <p><i>Step 2.</i> Using this area (A) and the axial force (P), the compressive stress was found in Example 2 to be</p> $\sigma = -\frac{P}{A} = -\frac{18,000 \text{ N}}{0.015 \text{ m}^2}$ $= -1,200,000 \text{ N/m}^2 = -1.2 \text{ MPa}$ <p><i>Step 3.</i> The moment of inertia (I) of the beam was found in Example 2 to be</p> $I = \frac{1}{12}bh^3 = \frac{1}{12}(0.05 \text{ m})(0.3 \text{ m})^3$ $= 0.0001125 \text{ m}^4$ <p><i>Step 4.</i> The maximum first moment (Q_{\max}) is needed, and is found for a rectangle using Eq. (1.41) as</p> $Q_{\max} = \frac{1}{8}bh^2 = \frac{1}{8}(0.05 \text{ m})(0.3 \text{ m})^2$ $= 0.0005625 \text{ m}^3$ <p><i>Step 5.</i> Substitute the shear force (V), the maximum first moment (Q_{\max}), the moment of inertia (I), and the width (b) in Eq. (1.39) for the shear stress due to bending to give</p> $\tau_{\max} = \frac{VQ_{\max}}{Ib}$ $= \frac{(45,000 \text{ N})(0.0005625 \text{ m}^3)}{(0.0001125 \text{ m}^4)(0.05 \text{ m})}$ $= \frac{25.3125 \text{ N} \cdot \text{m}^3}{0.00005625 \text{ m}^5}$ $= 4,500,000 \text{ N/m}^2 = 4.5 \text{ MPa}$

U.S. Customary	SI/Metric
<p><i>Step 6.</i> Display the answers for the maximum normal compressive stress (σ_{xx}) found in step 2 and the maximum shear stress (τ_{xy}) found in step 5, in kpsi, on a general stress element as</p>  <p>Remember, the directions of the stresses account for positive or negative signs. Also, as with the final diagrams of Examples 1 and 2, this diagram will be a starting point for the discussions in Chap. 5.</p>	<p><i>Step 6.</i> Display the answers for the maximum normal compressive stress (σ_{xx}) found in step 2 and the maximum shear stress (τ_{xy}) found in step 5, in kpsi, on a general stress element as</p>  <p>Remember, the directions of the stresses account for positive or negative signs. Also, as with the final diagrams of Examples 1 and 2, this diagram will be a starting point for the discussions in Chap. 5.</p>

4.4 AXIAL AND THERMAL

The third combination of loading to be considered is an axial load and a thermal load. This type of loading can occur when a machine element is put under a tensile, or compressive, preload during assembly in a factory environment, then subjected to an additional thermal load either due to a temperature drop in the winter or a temperature rise in the summer. Recall that if the machine element is not constrained, then under a temperature change the element merely gets longer or shorter and no stress is developed.

Figure 4.14 shows a thin-walled pipe, or tube, with flanges constrained between two fixed supports. (Note that typically pipe designations are based on inside diameter, whereas tubing is based on outside diameter.) Suppose that the original length of the pipe was shorter than the distance between the supports so that a tensile preload is developed in the pipe when it is installed. Also, suppose that what is of interest is the additional load that will be produced when the pipe is subjected to a temperature drop during the winter.

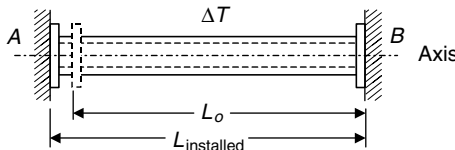

FIGURE 4.14 Axial and thermal loading.

The axial stress due to the lengthening of the pipe during installation is given by Eq. (4.5) where the axial strain (ϵ) is multiplied by the modulus of elasticity (E).

$$\sigma_{\text{axial}} = E \epsilon_{\text{axial}} = E \left(\frac{\Delta L}{L} \right) = E \left(\frac{L_{\text{installed}} - L_o}{L_o} \right) \quad (4.1)$$

The thermal stress due to a temperature drop (ΔT) is given by Eq. (4.6) where the thermal strain (ϵ_T) is multiplied by the modulus of elasticity (E)

$$\sigma_{\text{thermal}} = E\epsilon_T = E\alpha(\Delta T) \tag{4.2}$$

and (α) is the coefficient of thermal expansion of the pipe.

Combining these two normal stresses, both of which are constant over the cross section of the pipe, gives the single stress (σ_{xx}) shown in Eq. (4.3),

$$\sigma_{xx} = \sigma_{\text{axial}} + \sigma_{\text{thermal}} = E\epsilon_{\text{axial}} + E\epsilon_T = E \left[\frac{\Delta L}{L} + \alpha(\Delta T) \right] \tag{4.3}$$

where

$$\frac{\Delta L}{L} = \frac{L_{\text{installed}} - L_o}{L_o} \tag{4.4}$$

Stress Elements. The general stress element shown in Fig. 4.2 becomes the uniaxial stress element shown in Fig. 4.15, where the normal stress (σ_{xx}) is given by Eq. (4.3) and both the normal stress (σ_{yy}) and the shear stress (τ_{xy}) are zero.

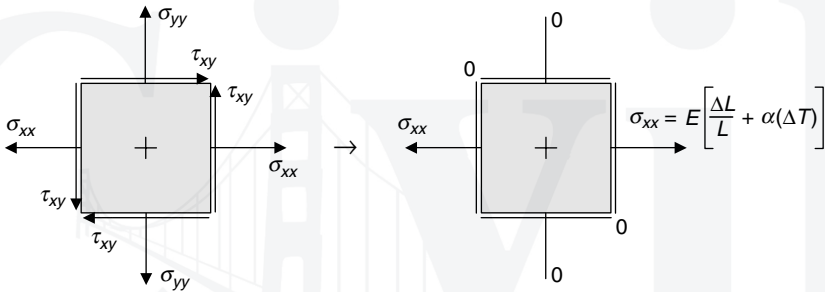
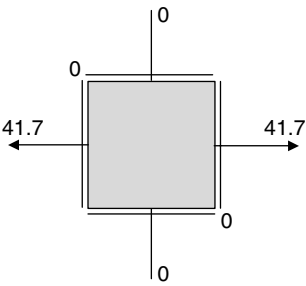
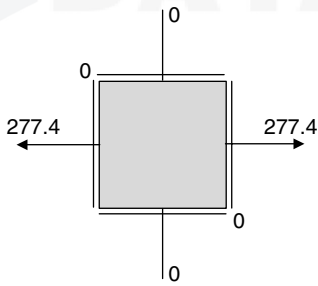

FIGURE 4.15 Stress element for axial and thermal loads.

U.S. Customary	SI/Metric
<p>Example 4. Determine the maximum stress (σ_{xx}) due to a combination of axial and thermal loads like those for the machine element in Fig. 4.14, where</p> <p style="margin-left: 40px;"> $L_o = 3 \text{ ft}$ (1/32 of an inch too short) $L_{\text{installed}} = 3.0026 \text{ ft}$ $\Delta T = -80^\circ\text{F}$ $\alpha = 6.5 \times 10^{-6} \text{ in/in} \cdot ^\circ\text{F}$ (steel) $E = 30 \times 10^6 \text{ lb/in}^2$ (steel) </p> <p>solution</p> <p><i>Step 1.</i> Calculate the axial strain (ϵ_{axial}) using Eq. (4.8) as</p> $\epsilon_{\text{axial}} = \frac{\Delta L}{L} = \frac{L_{\text{installed}} - L_o}{L_o}$ $= \frac{(3.0026 \text{ ft}) - (3 \text{ ft})}{(3 \text{ ft})}$ $= \frac{0.0026 \text{ ft}}{3 \text{ ft}} = 0.00087$	<p>Example 4. Determine the maximum stress (σ_{xx}) due to a combination of axial and thermal loads like those for the machine element in Fig. 4.14, where</p> <p style="margin-left: 40px;"> $L_o = 1 \text{ m}$ $L_{\text{installed}} = 1.0008 \text{ m}$ $\Delta T = -45^\circ\text{C}$ $\alpha = 12 \times 10^{-6} \text{ cm/cm} \cdot ^\circ\text{C}$ (steel) $E = 207 \times 10^9 \text{ N/m}^2$ (steel) </p> <p>solution</p> <p><i>Step 1.</i> Calculate the axial strain (ϵ_{axial}) using Eq. (4.8) as</p> $\epsilon_{\text{axial}} = \frac{\Delta L}{L} = \frac{L_{\text{installed}} - L_o}{L_o}$ $= \frac{(1.0008 \text{ m}) - (1 \text{ m})}{(1 \text{ m})}$ $= \frac{0.0008 \text{ m}}{1 \text{ m}} = 0.0008$

U.S. Customary	SI/Metric
<p><i>Step 2.</i> Calculate the axial stress (σ_{axial}) using Eq. (4.1) as</p> $\begin{aligned}\sigma_{\text{axial}} &= E\varepsilon_{\text{axial}} \\ &= (30 \times 10^6 \text{ lb/in}^2) (0.00087) \\ &= 26,100 \text{ lb/in}^2 = 26.1 \text{ kpsi}\end{aligned}$ <p><i>Step 3.</i> Calculate the thermal stress (σ_{thermal}) from Eq. (4.2) as</p> $\begin{aligned}\sigma_{\text{thermal}} &= E\varepsilon_T = E\alpha(\Delta T) \\ &= (30 \times 10^6 \text{ lb/in}^2) \\ &\quad \times (6.5 \times 10^{-6} \text{ in/in} \cdot ^\circ\text{F}) \\ &\quad \times (80 ^\circ\text{F}) \\ &= 15,600 \text{ lb/in}^2 \\ &= 15.6 \text{ kpsi}\end{aligned}$ <p><i>Step 4.</i> Combine the axial stress (σ_{axial}) from step 2 and the thermal stress (σ_{thermal}) from step 3 using Eq. (4.3) to give the maximum stress (σ_{xx}) as</p> $\begin{aligned}\sigma_{xx} &= \sigma_{\text{axial}} + \sigma_{\text{thermal}} \\ &= (26.1 \text{ kpsi}) + (15.6 \text{ kpsi}) \\ &= 41.7 \text{ kpsi}\end{aligned}$ <p><i>Step 5.</i> Display the answer for the maximum stress (σ_{xx}) found in step 4, in kpsi, on a plane stress element.</p> 	<p><i>Step 2.</i> Calculate the axial stress (σ_{axial}) using Eq. (4.1) as</p> $\begin{aligned}\sigma_{\text{axial}} &= E\varepsilon_{\text{axial}} \\ &= (207 \times 10^9 \text{ N/m}^2) (0.00087) \\ &= 165,600,000 \text{ N/m}^2 = 165.6 \text{ MPa}\end{aligned}$ <p><i>Step 3.</i> Calculate the thermal stress (σ_{thermal}) from Eq. (4.2) as</p> $\begin{aligned}\sigma_{\text{thermal}} &= E\varepsilon_T = E\alpha(\Delta T) \\ &= (207 \times 10^9 \text{ N/m}^2) \\ &\quad \times (12 \times 10^{-6} \text{ cm/cm} \cdot ^\circ\text{C}) \\ &\quad \times (45 ^\circ\text{C}) \\ &= 111,800,000 \text{ N/m}^2 \\ &= 111.8 \text{ MPa}\end{aligned}$ <p><i>Step 4.</i> Combine the axial stress (σ_{axial}) from step 2 and the thermal stress (σ_{thermal}) from step 3 using Eq. (4.3) to give the maximum stress (σ_{xx}) as</p> $\begin{aligned}\sigma_{xx} &= \sigma_{\text{axial}} + \sigma_{\text{thermal}} \\ &= (165.6 \text{ MPa}) + (111.8 \text{ MPa}) \\ &= 277.4 \text{ MPa}\end{aligned}$ <p><i>Step 5.</i> Display the answer for the maximum stress (σ_{xx}) found in step 4, in MPa, on a plane stress element.</p> 
<p>The above diagram will be a starting point for the discussions in Chap. 5.</p>	<p>The above diagram will be a starting point for the discussions in Chap. 5.</p>

4.5 TORSION AND BENDING

The fourth combination of loadings to be considered is torsion and bending. This is a very common loading for machine elements. Shown in Fig. 4.16 is a bent solid circular rod being used as a crank arm. The downward force (P) produces both a torsion and a bending in the shaft, with the resulting stresses maximized at the cantilevered wall support at point A.

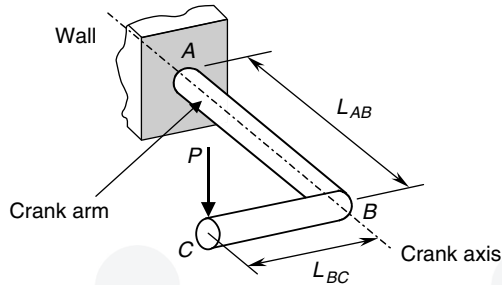

FIGURE 4.16 Torsion and bending loads.

The force (P) acting at point C on the crank arm produces a bending moment (M_B), or a torque (T_{AB}), about the crank axis AB, and is given by Eq. (4.5).

$$M_B = T_{AB} = P \times L_{BC} \quad (4.5)$$

The force (P) also produces a bending moment (M_A) at the wall and is given by Eq. (4.6).

$$M_A = P \times L_{AB} \quad (4.6)$$

A shear force (V) is developed in the crank arm and is equal to the magnitude of the applied force (P), that is,

$$V = P \quad (4.7)$$

Therefore, stress elements in the cross section of the crank arm at the wall are subjected to a torque (T_{AB}), a bending moment (M_A), and a shear force (V).

Location of Maximum Stress Elements. There are four plane stress elements to consider at the cross section of the crank arm at the wall. Two represent maximum stress values; however, the other two elements are important. Figure 4.17 shows these four special plane stress elements.

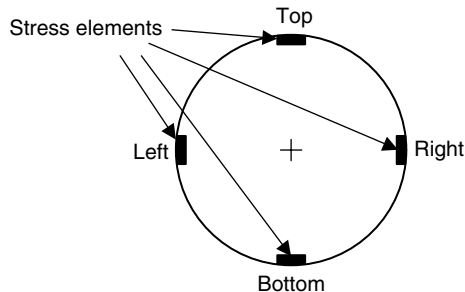

FIGURE 4.17 Special plane stress elements.

Starting with the *top* element, it is one of the two elements with maximum stresses, a normal stress (σ_{xx}) due to the bending moment (M_A) and a shear stress (τ_{xy}) due to the torque (T_{AB}). The normal stress (σ_{yy}) is zero.

The *left* element is the other element with maximum stresses, a shear stress (τ_{xy}) due to the torque (T_{AB}) and an additional shear stress (τ_{xy}) due to the shear force (V). Both normal stresses (σ_{xx}) and (σ_{yy}) are zero, making this a pure shear element.

The *bottom* element is similar to the *top* element, except that the normal stress (σ_{xx}) is compressive instead of tensile. Compressive is usually considered a lesser stress state than tensile, which is why this is not a maximum stress element.

The *right* element is similar to the *left* element, except that the two shear stresses (τ_{xy}) are opposite to each other, whereas they are in the same direction on the *left* element. This keeps it from being a maximum stress element.

Stress Elements. For the *top* element at the wall, the general stress element shown in Fig. 4.2 becomes the stress element shown in Fig. 4.18, where the normal stress (σ_{xx}) is the stress due to bending caused by the bending moment (M_A), the normal stress (σ_{yy}) is zero, and the shear stress (τ_{xy}) is the shear stress due to the torque (T_{AB}).

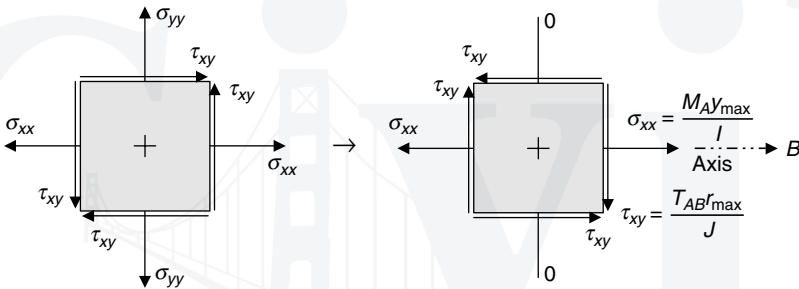

FIGURE 4.18 Stress element at the *top* side of the crank.

In Fig. 4.18, the view is downward on the *top* element, with the crank axis to the right toward point *B* as shown. The normal stress (σ_{xx}) is maximum on the *top* element, where the maximum distances (y_{max}) and (r_{max}) for a circular cross section are the outside radius (R). The shear stress due to torsion (τ_{xy}) is shown downward in Fig. 4.18; however, it is actually directed horizontally to the left when looking along the axis of the crank arm from point *B* to point *A*.

If the crank arm has a solid circular cross section, the moment of inertia (I) is given by Eq. (4.8),

$$I = \frac{1}{4} \pi R^4 \tag{4.8}$$

and the polar moment of inertia (J) is twice the moment of inertia (I), given in Eq. (4.9).

$$J = 2I = \frac{1}{2} \pi R^4 \tag{4.9}$$

Substituting for ($y_{max} = R$) and the moment of inertia (I) in Eq. (4.8), the normal stress (σ_{xx}) becomes the relationship given in Eq. (4.10).

$$\sigma_{xx} = \frac{M_A y_{max}}{I} = \frac{M_A R}{\frac{1}{4} \pi R^4} = \frac{4M_A}{\pi R^3} \tag{4.10}$$

Substituting for ($r_{\max} = R$) and the polar moment of inertia (J) in Eq. (4.9), the shear stress (τ_{xy}) becomes the relationship given in Eq. (4.11).

$$\tau_{xy} = \frac{T_{AB} r_{\max}}{J} = \frac{T_{AB} R}{\frac{1}{2} \pi R^4} = \frac{2 T_{AB}}{\pi R^3} \quad (4.11)$$

For the *left* element at the wall, the general stress element shown in Fig. 4.2 becomes the stress element shown in Fig. 4.19, where the normal stress (σ_{xx}) and the normal stress (σ_{yy}) are zero, and the shear stress (τ_{xy}) is a combination of the shear stress due to the torque (T_{AB}) and the shear stress due to bending caused by the shear force (V).

Both of these shear stresses will be maximum for the *left* element, directed downward as shown and forming a pure shear element.

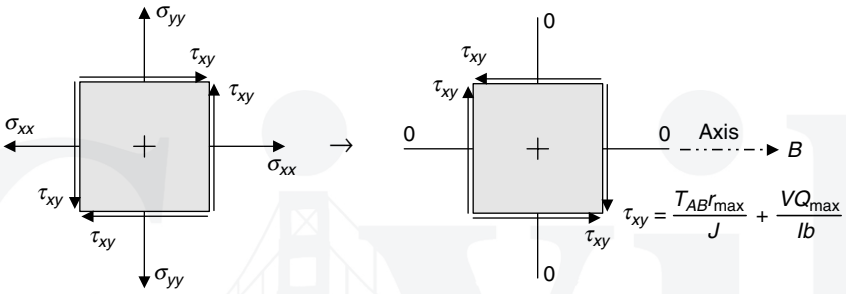

FIGURE 4.19 Special element on the *left* side of the crank.

In Fig. 4.19, the view is from the *left* side, with the crank axis to the right toward point B as shown. As mentioned earlier, the *right* element would look similar, except that the shear stresses would be in opposite directions rather than in the same direction as is the case of the *left* element.

For a solid circular cross section, the maximum first moment (Q_{\max}) is given by Eq. (4.12),

$$Q_{\max} = \frac{2}{3} R^3 \quad (4.12)$$

and the width (b) is equal to the diameter (D), which is equal to twice the radius ($2R$).

Substituting for (r_{\max}), (b), and using the moment of inertia (I) in Eq. (4.8) and the polar moment of inertia (J) in Eq. (4.9), the shear stress (τ_{xy}) acting on the *left* side element becomes the relationship given in Eq. (4.13),

$$\begin{aligned} \tau_{xy} &= \frac{T_{AB} r_{\max}}{J} + \frac{V Q_{\max}}{I b} \\ &= \frac{T_{AB} R}{\frac{1}{2} \pi R^4} + \frac{(V) \left(\frac{2}{3} R^3 \right)}{\left(\frac{1}{4} \pi R^4 \right) (2R)} \\ &= \frac{2 T_{AB}}{\pi R^3} + \frac{4}{3} \frac{V}{\pi R^2} \end{aligned} \quad (4.13)$$

Remember that the expressions for the maximum normal stress (σ_{xx}) and the maximum shear stress (τ_{xy}) given in Eqs. (4.10) and (4.11) for the *top* element and the expression for the maximum shear stress (τ_{xy}) for the *left* element are based on a crank arm that has

a solid circular cross section. If other cross sections are of interest, then these expressions should be modified accordingly.

Also notice that the second term in the third line of Eq. (4.13) is four-thirds the direct shear stress, which is the shear force (V) divided by the cross-sectional area (A).

U.S. Customary	SI/Metric
<p>Example 5. Determine the maximum stresses on the <i>top</i> element of a solid circular crank arm, like the one shown in Fig. 4.16, subjected to a downward applied force (P), where</p> $P = 500 \text{ lb}$ $L_{AB} = 2 \text{ ft} = 24 \text{ in}$ $L_{BC} = 1 \text{ ft} = 12 \text{ in}$ $R = 1.0 \text{ in}$ <p>solution</p> <p><i>Step 1.</i> Using Eq. (4.6), calculate the bending moment (M_A).</p> $M_A = P \times L_{AB} = (500 \text{ lb})(24.0 \text{ in})$ $= 12,000 \text{ in} \cdot \text{lb}$ <p><i>Step 2.</i> Using Eq. (4.5), calculate the torque (T_{AB}).</p> $T_{AB} = P \times L_{BC} = (500 \text{ lb})(12.0 \text{ in})$ $= 6,000 \text{ in} \cdot \text{lb}$ <p><i>Step 3.</i> Substitute the bending moment (M_A) and the radius (R) in Eq. (4.10) to give the normal stress (σ_{xx}).</p> $\sigma_{xx} = \frac{4M_A}{\pi R^3} = \frac{4(12,000 \text{ in} \cdot \text{lb})}{\pi (1.0 \text{ in})^3}$ $= \frac{48,000 \text{ in} \cdot \text{lb}}{3.14 \text{ in}^3}$ $= 15,279 \text{ lb/in}^2$ $= 15.3 \text{ kpsi}$ <p><i>Step 4.</i> Substitute the torque (T_{AB}) and the radius (R) in Eq. (4.11) to give the shear stress (τ_{xy}).</p> $\tau_{xy} = \frac{2T_{AB}}{\pi R^3} = \frac{2(6,000 \text{ in} \cdot \text{lb})}{\pi (1.0 \text{ in})^3}$ $= \frac{12,000 \text{ in} \cdot \text{lb}}{3.14 \text{ in}^3}$ $= 3,820 \text{ lb/in}^2$ $= 3.8 \text{ kpsi}$	<p>Example 5. Determine the maximum stresses on the <i>top</i> element of a solid circular crank arm, like the one shown in Fig. 4.16, subjected to a downward applied force (P), where</p> $P = 2,250 \text{ N}$ $L_{AB} = 0.8 \text{ m}$ $L_{BC} = 0.4 \text{ m}$ $R = 2.5 \text{ cm} = 0.025 \text{ m}$ <p>solution</p> <p><i>Step 1.</i> Using Eq. (4.6), calculate the bending moment (M_A).</p> $M_A = P \times L_{AB} = (2,250 \text{ N})(0.80 \text{ m})$ $= 1,800 \text{ N} \cdot \text{m}$ <p><i>Step 2.</i> Using Eq. (4.5), calculate the torque (T_{AB}).</p> $T_{AB} = P \times L_{BC} = (2,250 \text{ N})(0.40 \text{ m})$ $= 900 \text{ N} \cdot \text{m}$ <p><i>Step 3.</i> Substitute the bending moment (M_A) and the radius (R) in Eq. (4.10) to give the normal stress (σ_{xx}).</p> $\sigma_{xx} = \frac{4M_A}{\pi R^3} = \frac{4(1,800 \text{ N} \cdot \text{m})}{\pi (0.025 \text{ m})^3}$ $= \frac{7,200 \text{ N} \cdot \text{m}}{0.0000491 \text{ m}^3}$ $= 146,680,000 \text{ N/m}^2$ $= 146.7 \text{ MPa}$ <p><i>Step 4.</i> Substitute the torque (T_{AB}) and the radius (R) in Eq. (4.11) to give the shear stress (τ_{xy}).</p> $\tau_{xy} = \frac{2T_{AB}}{\pi R^3} = \frac{2(900 \text{ N} \cdot \text{m})}{\pi (0.025 \text{ m})^3}$ $= \frac{1,800 \text{ N} \cdot \text{m}}{0.0000491 \text{ m}^3}$ $= 36,670,000 \text{ N/m}^2$ $= 36.7 \text{ MPa}$

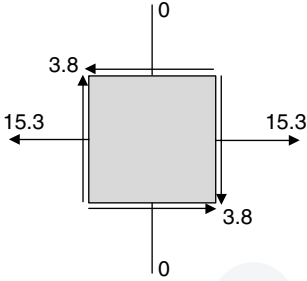
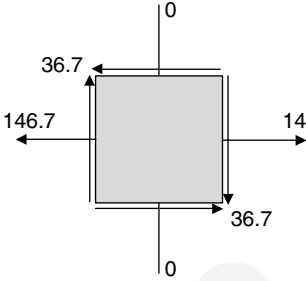
U.S. Customary	SI/Metric
<p><i>Step 5.</i> Display the answers for the normal stress (σ_{xx}) found in step 3 and the shear stress (τ_{xy}) found in step 4, in kpsi, on the <i>top</i> stress element of Fig. 4.18.</p> 	<p><i>Step 5.</i> Display the answers for the normal stress (σ_{xx}) found in step 3 and the shear stress (τ_{xy}) found in step 4, in MPa, on the <i>top</i> stress element of Fig. 4.18.</p> 
<p>Again, this stress element diagram will be a starting point for the discussions in Chap. 5.</p>	<p>Again, this stress element diagram will be a starting point for the discussions in Chap. 5.</p>
<p>Example 6. Determine the maximum stresses on the <i>left</i> element of a solid circular crank arm, using Fig. 4.16 and the given information from Example 5, where</p> <p>$P = 500$ lb $L_{AB} = 2$ ft = 24 in $L_{BC} = 1$ ft = 12 in $R = 1.0$ in</p>	<p>Example 6. Determine the maximum stresses on the <i>left</i> element of a solid circular crank arm, using Fig. 4.16 and the given information from Example 5, where</p> <p>$P = 2,250$ N $L_{AB} = 0.8$ m $L_{BC} = 0.4$ m $R = 2.5$ cm = 0.025 m</p>
<p>solution</p> <p><i>Step 1.</i> In step 4 of Example 5, the shear stress (τ_{xy}) due to the torque (T_{AB}) was found to be</p> $\tau_{xy} = 3,820 \text{ lb/in}^2 = 3.8 \text{ kpsi}$	<p>solution</p> <p><i>Step 1.</i> In step 4 of Example 5, the shear stress (τ_{xy}) due to the torque (T_{AB}) was found to be</p> $\tau_{xy} = 36,670,000 \text{ N/m}^2 = 36.7 \text{ MPa}$
<p><i>Step 2.</i> From Eq. (4.7), the shear force (V) is equal to the applied force (P)</p> $V = P = 500 \text{ lb}$	<p><i>Step 2.</i> From Eq. (4.7), the shear force (V) is equal to the applied force (P)</p> $V = P = 2,250 \text{ N}$
<p><i>Step 3.</i> Substitute the shear force (V) and the radius (R) in the second term on the third line of Eq. (4.13) to give</p> $\begin{aligned} \tau_{xy} &= \frac{4}{3} \frac{V}{\pi R^2} = \frac{4(500 \text{ lb})}{3\pi(1.0 \text{ in})^2} \\ &= \frac{2,000 \text{ lb}}{9.425 \text{ in}^2} \\ &= 212 \text{ lb/in}^2 = 0.2 \text{ kpsi} \end{aligned}$	<p><i>Step 3.</i> Substitute the shear force (V) and the radius (R) in the second term of the third line of Eq. (4.13) to give</p> $\begin{aligned} \tau_{xy} &= \frac{4}{3} \frac{V}{\pi R^2} = \frac{4(2,250 \text{ N})}{3\pi(0.025 \text{ m})^2} \\ &= \frac{9,000 \text{ N}}{0.00589 \text{ m}^2} \\ &= 1,528,000 \text{ N/m}^2 = 1.5 \text{ MPa} \end{aligned}$

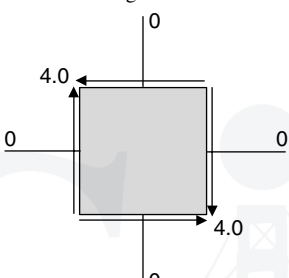
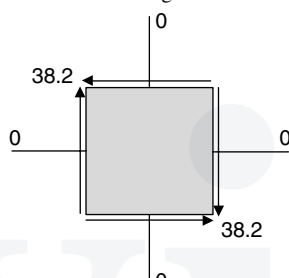
U.S. Customary	SI/Metric
<p><i>Step 4.</i> Combine the shear stress due to the torque (T_{AB}) from step 1 and the shear stress due to bending from step 3 using the expression in Eq. (4.13) to give</p> $\tau_{xy} = \frac{2 T_{AB}}{\pi R^3} + \frac{4}{3} \frac{V}{\pi R^2}$ $= 3.8 \text{ kpsi} + 0.2 \text{ kpsi} = 4.0 \text{ kpsi}$ <p><i>Step 5.</i> Display the answer for the maximum shear stress (τ_{xy}) found in step 4, in kpsi, on the <i>left</i> stress element in Fig. 4.19.</p>  <p>As with the previous examples, this stress element diagram will be a starting point for the discussions in Chap. 5.</p>	<p><i>Step 4.</i> Combine the shear stress due to the torque (T_{AB}) from step 1 and the shear stress due to bending from step 3 using the expression in Eq. (4.13) to give</p> $\tau_{xy} = \frac{2 T_{AB}}{\pi R^3} + \frac{4}{3} \frac{V}{\pi R^2}$ $= 36.7 \text{ MPa} + 1.5 \text{ MPa} = 38.2 \text{ MPa}$ <p><i>Step 5.</i> Display the answer for the maximum shear stress (τ_{xy}) found in step 4, in kpsi, on the <i>left</i> stress element in Fig. 4.19.</p>  <p>As with the previous examples, this stress element diagram will be a starting point for the discussions in Chap. 5.</p>

4.6 AXIAL AND PRESSURE

The fifth combination of loading to be considered as an axial load and a pressure load. This type of loading is quite common in piping systems where a compressive or tensile preload is placed on a section of pipe during installation and is in conjunction with the load due to the internal pressure in the pipe. Pipe dimensions are typically based on internal diameter with a standard wall thickness for each strength designation. As wall thicknesses of pipes are small compared to the diameter, pipes can be considered to be thin-walled cylinders.

Figure 4.20 shows a thin-walled pipe with flanges constrained between two fixed supports, and under an internal pressure (p_i). Like in Sec. 4.1.3 where an axial and thermal loading was discussed, suppose that again the original length of the pipe was shorter than the

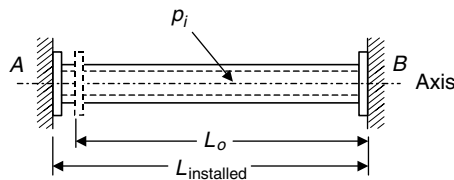

FIGURE 4.20 Axial and pressure loading.

distance between the supports so that a tensile preload is developed in the pipe when it is installed. What is of interest is the maximum stress that the pipe will be subjected to by the combination of the improper installation and the operational pressure.

As a review, the axial stress due to the lengthening of the pipe during installation is given by Eq. (4.14), which is an application of Hooke's law,

$$\sigma_{\text{axial}} = E \varepsilon_{\text{axial}} = E \left(\frac{\Delta L}{L} \right) = E \left(\frac{L_{\text{installed}} - L_o}{L_o} \right) \quad (4.14)$$

where (E) is the modulus of elasticity of the pipe.

The internal pressure (p_i) produces two normal stresses in the wall of the pipe, an axial stress (σ_{axial}) and a hoop stress (σ_{hoop}) given in Eqs. (4.15) and (4.16).

$$\sigma_{\text{axial}} = \frac{p_i r_m}{2t} \quad (4.15)$$

$$\sigma_{\text{hoop}} = \frac{p_i r_m}{t} \quad (4.16)$$

where (r_m) is the mean radius (which can be assumed to be the inside radius) and (t) is the wall thickness of the pipe. Notice that the hoop stress is twice the axial stress.

Stress Elements. The general stress element shown in Fig. 4.2 becomes the biaxial stress element shown in Fig. 4.21, where the normal stress (σ_{xx}) is a combination of the axial stress due to improper installation given by Eq. (4.14) and the axial stress due to internal pressure given by Eq. (4.15), the normal stress (σ_{yy}) is the hoop stress given by Eq. (4.16), and the shear stress (τ_{xy}) is zero.

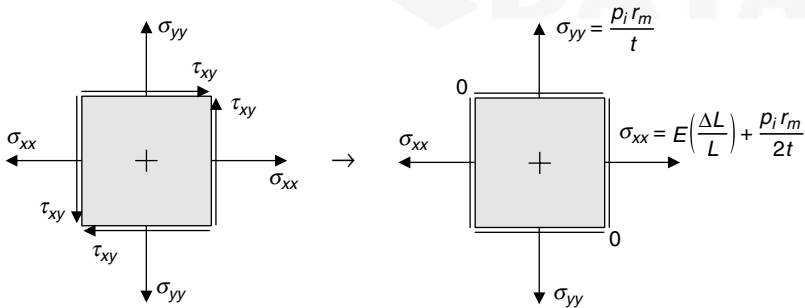
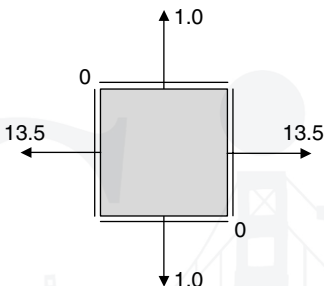
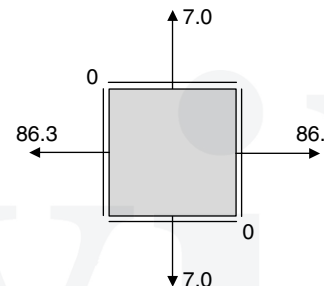

FIGURE 4.21 Stress element for axial and pressure loads.

Let us look at an example to see how these stresses combine quantitatively.

U.S. Customary	SI/Metric
<p>Example 7. Determine the maximum biaxial stresses (σ_{xx}) and (σ_{yy}) due to a combination of axial and pressure loads like those for the piping installation in Fig. 4.20, where</p> $L_o = 12 \text{ ft (1/16 of an inch too short)}$ $L_{\text{installed}} = 12.00521 \text{ ft}$ $E = 30 \times 10^6 \text{ lb/in}^2 \text{ (steel)}$ $p_i = 200 \text{ psi}$ $r_m = 1.5 \text{ in}$ $t = 0.3 \text{ in}$ <p>solution</p> <p><i>Step 1.</i> Calculate the axial strain (ϵ_{axial}) due to improper installation using Eq. (4.14) as</p> $\begin{aligned} \epsilon_{\text{axial}} &= \frac{\Delta L}{L} = \frac{L_{\text{installed}} - L_o}{L_o} \\ &= \frac{(12.00521 \text{ ft}) - (12 \text{ ft})}{(12 \text{ ft})} \\ &= \frac{0.00521 \text{ ft}}{12 \text{ ft}} = 0.000434 \end{aligned}$ <p><i>Step 2.</i> Calculate the axial stress (σ_{axial}) because of improper installation, again using Eq. (4.14) as</p> $\begin{aligned} \sigma_{\text{axial}} &= E \epsilon_{\text{axial}} \\ &= (30 \times 10^6 \text{ lb/in}^2)(0.000434) \\ &= 13,021 \text{ lb/in}^2 = 13.0 \text{ kpsi} \end{aligned}$ <p><i>Step 3.</i> Calculate the axial stress (σ_{axial}) due to the internal pressure from Eq. (4.15) as</p> $\begin{aligned} \sigma_{\text{axial}} &= \frac{p_i r_m}{2t} \\ &= \frac{(200 \text{ lb/in}^2)(1.5 \text{ in})}{2(0.3 \text{ in})} \\ &= \frac{300 \text{ lb/in}}{0.6 \text{ in}} \\ &= 500 \text{ lb/in}^2 = 0.5 \text{ kpsi} \end{aligned}$ <p><i>Step 4.</i> Calculate the hoop stress (σ_{hoop}) due to the internal pressure from Eq. (4.16) as</p> $\begin{aligned} \sigma_{\text{hoop}} &= \frac{p_i r_m}{t} \\ &= \frac{(200 \text{ lb/in}^2)(1.5 \text{ in})}{(0.3 \text{ in})} \\ &= \frac{300 \text{ lb/in}}{0.3 \text{ in}} \\ &= 1,000 \text{ lb/in}^2 = 1.0 \text{ kpsi} \end{aligned}$	<p>Example 7. Determine the maximum biaxial stresses (σ_{xx}) and (σ_{yy}) due to a combination of axial and pressure loads like those for the piping installation in Fig. 4.20, where</p> $L_o = 4 \text{ m}$ $L_{\text{installed}} = 1.0016 \text{ m}$ $E = 207 \times 10^9 \text{ N/m}^2 \text{ (steel)}$ $p_i = 1.4 \text{ MPa} = 1,400,000 \text{ N/m}^2$ $r_m = 4 \text{ cm} = 0.04 \text{ m}$ $t = 0.8 \text{ cm} = 0.008 \text{ m}$ <p>solution</p> <p><i>Step 1.</i> Calculate the axial strain (ϵ_{axial}) due to improper installation using Eq. (4.14) as</p> $\begin{aligned} \epsilon_{\text{axial}} &= \frac{\Delta L}{L} = \frac{L_{\text{installed}} - L_o}{L_o} \\ &= \frac{(4.0016 \text{ m}) - (4 \text{ m})}{(4 \text{ m})} \\ &= \frac{0.0016 \text{ m}}{4 \text{ m}} = 0.0004 \end{aligned}$ <p><i>Step 2.</i> Calculate the axial stress (σ_{axial}) due to improper installation, again using Eq. (4.14) as</p> $\begin{aligned} \sigma_{\text{axial}} &= E \epsilon_{\text{axial}} \\ &= (207 \times 10^9 \text{ N/m}^2)(0.0004) \\ &= 82,800,000 \text{ N/m}^2 = 82.8 \text{ MPa} \end{aligned}$ <p><i>Step 3.</i> Calculate the axial stress (σ_{axial}) due to the internal pressure from Eq. (4.15) as</p> $\begin{aligned} \sigma_{\text{axial}} &= \frac{p_i r_m}{2t} \\ &= \frac{(1,400,000 \text{ N/m}^2)(0.04 \text{ m})}{2(0.008 \text{ m})} \\ &= \frac{56,000 \text{ N/m}}{0.016 \text{ m}} \\ &= 3,500,000 \text{ N/m}^2 = 3.5 \text{ MPa} \end{aligned}$ <p><i>Step 4.</i> Calculate the hoop stress (σ_{hoop}) due to the internal pressure from Eq. (4.16) as</p> $\begin{aligned} \sigma_{\text{hoop}} &= \frac{p_i r_m}{t} \\ &= \frac{(1,400,000 \text{ N/m}^2)(0.04 \text{ m})}{(0.008 \text{ m})} \\ &= \frac{56,000 \text{ N/m}}{0.008 \text{ m}} \\ &= 7,000,000 \text{ N/m}^2 = 7.0 \text{ MPa} \end{aligned}$

U.S. Customary	SI/Metric
<p><i>Step 5.</i> Combine the axial stress (σ_{axial}) from step 2 and the axial stress (σ_{axial}) from step 3 to give the maximum stress (σ_{xx}) as</p> $\begin{aligned}\sigma_{xx} &= \sigma_{axial} + \sigma_{axial} \\ &= (13.0 \text{ kpsi}) + (0.5 \text{ kpsi}) \\ &= 13.5 \text{ kpsi}\end{aligned}$ <p><i>Step 6.</i> Display the answers for the maximum stress (σ_{xx}) found in step 5, and the hoop stress found in step 4, in kpsi, on the biaxial stress element of Fig. 4.21.</p>  <p>The above diagram will be a starting point for the discussions in Chap. 5.</p>	<p><i>Step 5.</i> Combine the axial stress (σ_{axial}) from step 2 and the axial stress (σ_{axial}) from step 3 to give the maximum stress (σ_{xx}) as</p> $\begin{aligned}\sigma_{xx} &= \sigma_{axial} + \sigma_{axial} \\ &= (82.8 \text{ MPa}) + (3.5 \text{ MPa}) \\ &= 86.3 \text{ MPa}\end{aligned}$ <p><i>Step 6.</i> Display the answers for the maximum stress (σ_{xx}) found in step 5 and the hoop stress found in step 4, in MPa, on the biaxial stress element of Fig. 4.21.</p>  <p>The above diagram will be a starting point for the discussions in Chap. 5.</p>

4.7 TORSION AND PRESSURE

The sixth combination of loadings to be considered is torsion and pressure. This type of loading could occur when a spur gear is press fitted onto a shaft. The tangential and radial stresses developed at the interface between the gear and shaft will be coupled with the shear stress produced by the torque applied to the gear by a mating gear. A press fitted spur gear and shaft assembly is shown in Fig. 4.22.

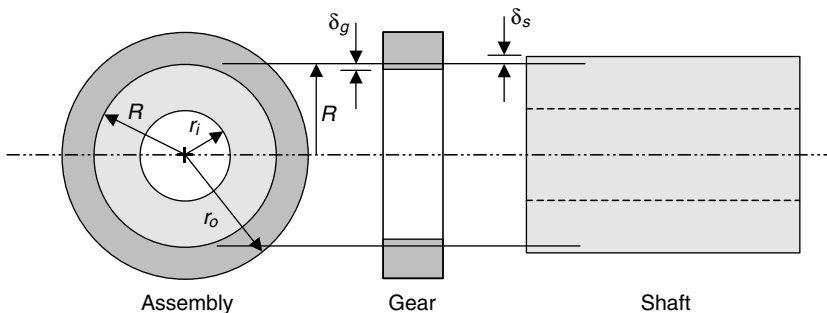

FIGURE 4.22 Torsion and pressure loading.

As a review of Sec. 3.2.3 on press or shrink fits, at the interface between the spur gear and the solid shaft, at the radius (R), the gear increases an amount (δ_g) radially and the inside shaft decreases an amount (δ_s) radially. The difference between the radial increase (δ_g) of the gear, a positive number, and the radial decrease (δ_s) of the shaft, a negative number, is called the radial interference (δ) at the interface (R) and is given by Eq. (4.17),

$$\delta = \delta_g + |\delta_s| = \frac{pR}{E_g} \left(\frac{r_o^2 + R^2}{r_o^2 - R^2} + \nu_g \right) + \frac{pR}{E_s} \left(\frac{R^2 + r_i^2}{R^2 - r_i^2} - \nu_s \right) \quad (4.17)$$

where (E_g) and (E_s) are the moduli of elasticities, and (ν_g) and (ν_s) are the Poisson ratios of the spur gear and shaft, respectively.

When the radial interference (δ) is determined from a particular fit specification, and this is discussed in detail in Sec. 3.2.3, then Eq. (4.17) can be solved for the interference pressure (P). However, if the spur gear and shaft are made of the same material, then the modulus of elasticity's and Poisson's ratio are equal and so Eq. (4.17) can be rearranged to give an expression for the interface pressure (P) given in Eq. (4.18).

$$p = \frac{E\delta}{R} \left[\frac{(r_o^2 - R^2)(R^2 - r_i^2)}{2R^2(r_o^2 - r_i^2)} \right] \quad (4.18)$$

If the inner shaft is solid, meaning the inside radius (r_i) is zero, then Eq. (4.18) for the interface pressure (P) simplifies to the expression in Eq. (4.19)

$$p = \frac{E\delta}{2R} \left[1 - \left(\frac{R}{r_o} \right)^2 \right] \quad (4.19)$$

Again, just as a review, consider the following calculation for the interface pressure (P) based on a given, or previously determined, radial interference (δ).

U.S. Customary	SI/Metric
<p>Example 8. Calculate the interface pressure (P) for a solid shaft and spur gear assembly, with both parts steel, where</p> <p>$\delta = 0.0005$ in $R = 0.75$ in $r_o = 4$ in $E = 30 \times 10^6$ lb/in² (steel)</p> <p>solution <i>Step 1.</i> Substitute the radial interface (δ), interface radius (R), outside radius (r_o) of the spur gear, and the modulus of elasticity (E) in Eq. (4.19) to give</p>	<p>Example 8. Calculate the interface pressure (P) for a solid shaft and spur gear assembly, with both parts steel, where</p> <p>$\delta = 0.001$cm = 0.00001 m $R = 2$ cm = 0.02 m $r_o = 10$ cm = 0.1 m $E = 207 \times 10^9$ N/m² (steel)</p> <p>solution <i>Step 1.</i> Substitute the radial interface (δ), interface radius (R), outside radius (r_o) of the spur gear, and the modulus of elasticity (E) in Eq. (4.19) to give</p>

U.S. Customary	SI/Metric
$p = \frac{E\delta}{2R} \left[1 - \left(\frac{R}{r_o} \right)^2 \right]$ $= \frac{(30 \times 10^6 \text{ lb/in}^2)(0.0005 \text{ in})}{2(0.75 \text{ in})}$ $\times \left[1 - \left(\frac{0.75 \text{ in}}{4 \text{ in}} \right)^2 \right]$ $= \frac{15,000 \text{ lb/in}}{1.5 \text{ in}}(1 - 0.035)$ $= (10,000 \text{ lb/in}^2)(0.965)$ $= 9,650 \text{ lb/in}^2 = 9.65 \text{ kpsi}$	$p = \frac{E\delta}{2R} \left[1 - \left(\frac{R}{r_o} \right)^2 \right]$ $= \frac{(207 \times 10^9 \text{ N/m}^2)(0.00001 \text{ m})}{2(0.02 \text{ m})}$ $\times \left[1 - \left(\frac{0.02 \text{ m}}{0.1 \text{ m}} \right)^2 \right]$ $= \frac{2,070,000 \text{ N/m}}{0.04 \text{ m}}(1 - 0.04)$ $= (51,750,000 \text{ N/m}^2)(0.96)$ $= 49,680,000 \text{ N/m}^2 = 49.68 \text{ MPa}$

Location of the Maximum Stress Element. Figure 4.23 shows a press fitted gear (no teeth shown) and solid shaft assembly with the relative dimensions of the assembly in Example 8.

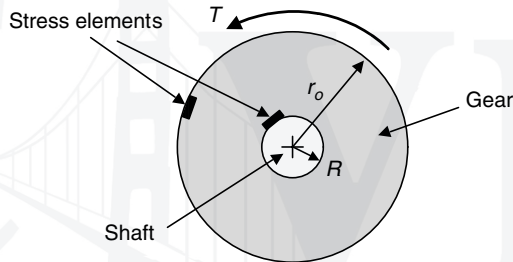

FIGURE 4.23 Element for maximum stress.

Two stress elements are identified in Fig. 4.23, and the determination of which one has the maximum stress state is related to how the individual stresses due to the combination of loads vary with respect to the radius (r) from the center of the assembly. Also, the two elements shown are not specific to a particular angular location around the assembly. What follows is a discussion of how the maximum stress element is chosen.

First, the counterclockwise torque (T) is caused by a mating spur gear not shown. This torque produces a shear stress (τ_{xy}) in the body of the spur gear that is maximum at the outside radius (r_o), usually taken as the radius to the root of the teeth of the gear, and minimum at the the inside radius of the gear that is, the interface radius (R). (The stresses on the gear teeth themselves is a topic in itself, not covered in this book.)

The shear stress (τ_{xy}) due to the torque (T) is given by Eq. (4.20)

$$\tau_{xy} = \frac{Tr}{J} \quad (4.20)$$

where the polar moment of inertia (J) for the gear is given by Eq. (4.21) as

$$J = \frac{1}{2} \pi (r_o^4 - R^4) \quad (4.21)$$

At the outside radius (r_o) of the gear, the shear stress (τ_{xy}) is maximum and from Eq. (4.20) and the polar moment of inertia (J) in Eq. (4.21) becomes Eq. (4.22).

$$\tau_{\max} = \frac{Tr_o}{J} = \frac{Tr_o}{\frac{1}{2} \pi (r_o^4 - R^4)} = \frac{2Tr_o}{\pi (r_o^4 - R^4)} \quad (4.22)$$

At the inside radius (R) of the gear, the shear stress (τ_{xy}) is minimum and from Eq. (4.20) and the polar moment of inertia (J) in Eq. (4.21) becomes Eq. (4.23).

$$\tau_{\min} = \frac{TR}{J} = \frac{TR}{\frac{1}{2} \pi (r_o^4 - R^4)} = \frac{2TR}{\pi (r_o^4 - R^4)} \quad (4.23)$$

Second, the interface pressure (P) between the gear and the shaft, like that determined in Example 8, causes both a tangential stress (σ_t) given by Eq. (4.24),

$$\sigma_t = \frac{pR^2}{r_o^2 - R^2} \left[1 + \left(\frac{r_o}{r} \right)^2 \right] \quad (4.24)$$

and a radial stress (σ_r) given by Eq. (4.25).

$$\sigma_r = \frac{pR^2}{r_o^2 - R^2} \left[1 - \left(\frac{r_o}{r} \right)^2 \right] \quad (4.25)$$

However, tangential and radial stresses are a maximum at the interface radius (R) where the shear stress due to the torque would be minimum. Recall that in Sec. 3.2.2 it was shown that the radial stress (σ_r) at the inside radius of a thick-walled cylinder is the negative of the internal pressure (p_i), which here is the interface pressure (P). It was also shown that the minimum radial stress (σ_r) was zero at the outside radius (r_o).

Therefore, at the radial interface (R), the tangential stress (σ_t) given in Eq. (4.24) becomes a maximum value (σ_t^{\max}), with the algebraic steps shown in Eq. (4.26),

$$\sigma_t^{\max} = \underbrace{\frac{pR^2}{r_o^2 - R^2} \left[1 + \left(\frac{r_o}{R} \right)^2 \right]}_{\text{Eq. (1.90) with } r = R} = \underbrace{\frac{pR^2}{r_o^2 - R^2} \left[\frac{R^2 + r_o^2}{R^2} \right]}_{\text{find common denominator}} = \underbrace{p \left[\frac{r_o^2 + R^2}{r_o^2 - R^2} \right]}_{\text{rearrange and cancel terms}} \quad (4.26)$$

and the radial stress (σ_r) given in Eq. (1.91) becomes a maximum value (σ_r^{\max}) equal to the negative of the interface pressure (P), with the algebraic steps shown in Eq. (4.27).

$$\sigma_r^{\max} = \underbrace{\frac{pR^2}{r_o^2 - R^2} \left[1 - \left(\frac{r_o}{R} \right)^2 \right]}_{\text{Eq. (1.91) with } r = R} = \underbrace{\frac{pR^2}{r_o^2 - R^2} \left[\frac{R^2 - r_o^2}{R^2} \right]}_{\text{find common denominator}} = \underbrace{\frac{pR^2}{R^2} \left[\frac{-(r_o^2 - R^2)}{r_o^2 - R^2} \right]}_{\text{rearrange and cancel terms}} = -p \quad (4.27)$$

Similarly, at the outside radius (r_o), the tangential stress (σ_t) given in Eq. (4.24) becomes a minimum value (σ_t^{\min}), with the algebraic steps shown in Eq. (4.28),

$$\sigma_t^{\min} = \underbrace{\frac{pR^2}{r_o^2 - R^2} \left[1 + \left(\frac{r_o}{r_o} \right)^2 \right]}_{\text{Eq. (1.90) with } r = r_o} = \underbrace{\frac{pR^2}{r_o^2 - R^2} [1 + 1]}_{\text{simplify bracket terms}} = \underbrace{\frac{2pR^2}{r_o^2 - R^2}}_{\text{rearrange}} \quad (4.28)$$

and the radial stress (σ_r) given in Eq. (4.25) becomes a minimum value (σ_r^{\min}), and as stated earlier is equal to zero, with the algebraic steps shown in Eq. (4.29).

$$\sigma_r^{\min} = \underbrace{\frac{pR^2}{r_o^2 - R^2} \left[1 - \left(\frac{r_o}{r_o} \right)^2 \right]}_{\text{Eq. (1.91) with } r=r_o} = \underbrace{\frac{pR^2}{r_o^2 - R^2} [1 - 1]}_{\text{simplify bracket terms}} = 0 \quad (4.29)$$

Stress Elements. The general stress element shown in Fig. 4.2 becomes the stress element shown in Fig. 4.24, where the normal stress (σ_{xx}) is the tangential stress (σ_t) given by Eq. (4.24) due to the interface pressure (P), the normal stress (σ_{yy}) is zero, and the shear stress (τ_{xy}) is the shear stress due to the torque (T) given by Eq. (4.20).

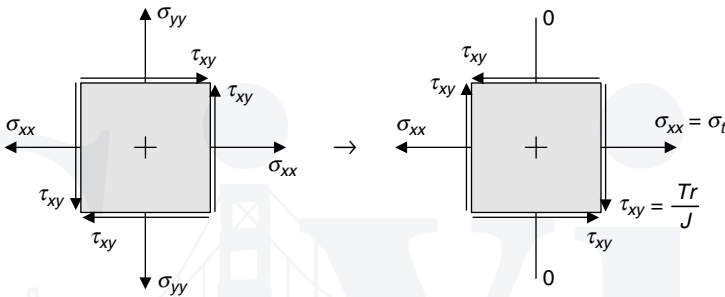

FIGURE 4.24 Stress element for torsion and pressure.

The stress element in Fig. 4.25 is somewhat misleading in that it is not oriented according to the arrangement of the elements in Fig. 4.23. Also, the radial stress (σ_r) cannot be shown in this diagram. A better diagram is given in Fig. 4.26, where both the edge and plan views are provided, aligned along the *axis* of the assembly.

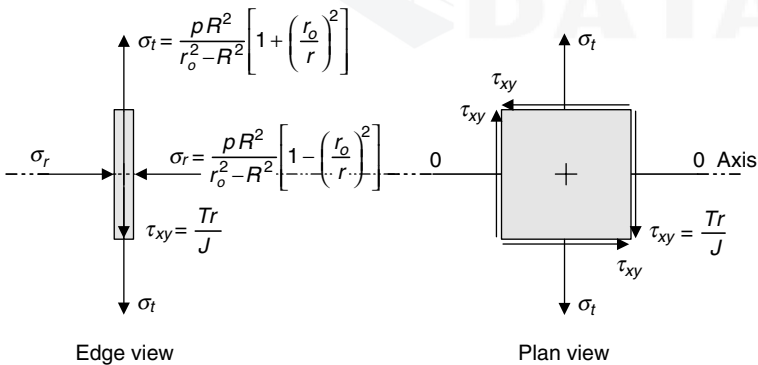

FIGURE 4.25 Edge and plan views of stress element.

For the stress element at the outside radius (r_o), Fig. 4.25 becomes Fig. 4.26. For the stress element at the radial interface (R), Fig. 4.25 becomes Fig. 4.27.

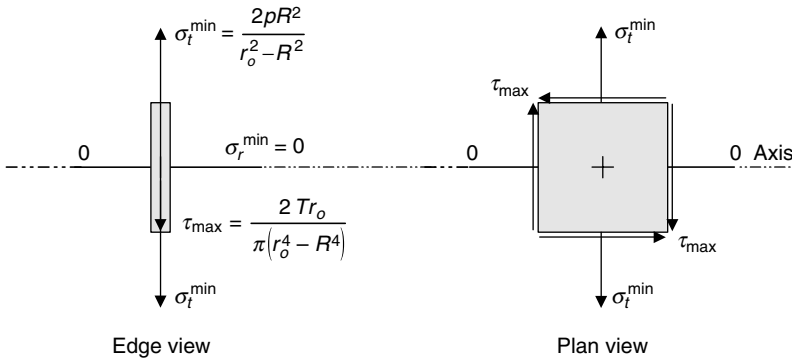

FIGURE 4.26 Stress element at the outside radius.

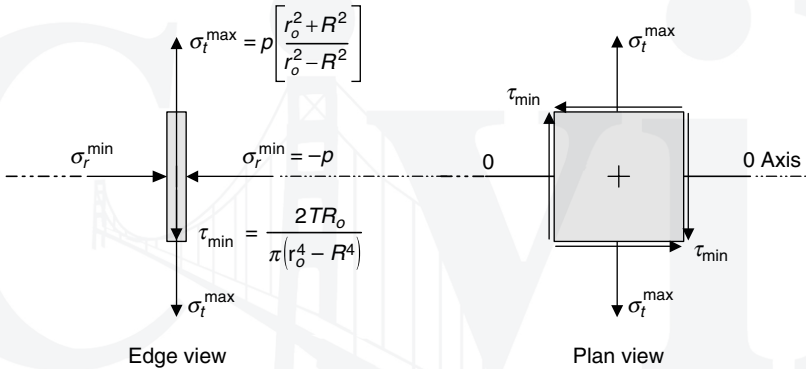
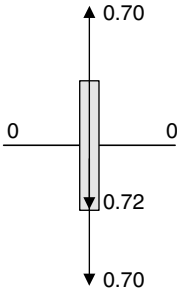
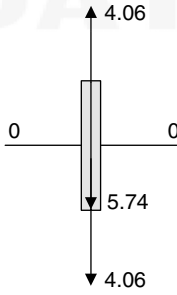
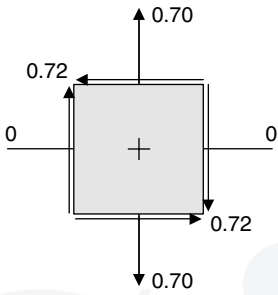
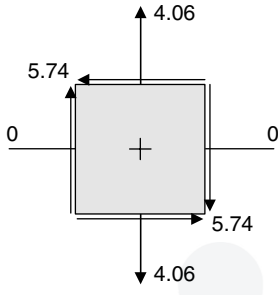

FIGURE 4.27 Stress element at the radial interface.

The following quantitative calculations will provide the information needed to decide which of the two stress elements shown in Figs. 4.26 and 4.27 have the maximum stresses. Example 9 will look at the stresses on the element in Fig. 4.26, and Example 10 will look at the stresses on the element in Fig. 4.27.

U.S. Customary	SI/Metric
<p>Example 9. Determine the stresses on the element in Fig. 4.26 using the dimensions of the spur gear and shaft assembly in Example 8, the interface pressure (P) found, and a torque applied to the gear at the outside radius equal to</p> <p>$T = 6,000 \text{ ft} \cdot \text{lb} = 72,000 \text{ in} \cdot \text{lb}$ $R = 0.75 \text{ in}$ $r_o = 4 \text{ in}$ $p = 9,650 \text{ lb/in}^2$</p>	<p>Example 9. Determine the stresses on the element in Fig. 4.26 using the dimensions of the spur gear and shaft assembly in Example 8, the interface pressure p found, and a torque applied to the gear at the outside radius equal to</p> <p>$T = 9,000 \text{ N} \cdot \text{m}$ $R = 2 \text{ cm} = 0.02 \text{ m}$ $r_o = 10 \text{ cm} = 0.1 \text{ m}$ $p = 48,680,000 \text{ N/m}^2$</p>

U.S. Customary	SI/Metric
<p>solution</p> <p><i>Step 1.</i> Calculate the maximum shear stress using Eq. (4.22).</p> $\begin{aligned}\tau_{\max} &= \frac{2Tr_o}{\pi (r_o^4 - R^4)} \\ &= \frac{2(72,000 \text{ lb} \cdot \text{in})(4.0 \text{ in})}{\pi ((4 \text{ in})^4 - (0.75 \text{ in})^4)} \\ &= \frac{576,000 \text{ lb} \cdot \text{in}^2}{803 \text{ in}^4} \\ &= 717 \text{ lb/in}^2 = 0.72 \text{ kpsi}\end{aligned}$ <p><i>Step 2.</i> Calculate the minimum tangential stress using Eq. (4.28).</p> $\begin{aligned}\sigma_t^{\min} &= \frac{2pR^2}{r_o^2 - R^2} \\ &= \frac{2(9,650 \text{ lb/in}^2)(0.75 \text{ in})^2}{(4 \text{ in})^2 - (0.75 \text{ in})^2} \\ &= \frac{10,856 \text{ lb}}{15.4375 \text{ in}^2} \\ &= 703 \text{ lb/in}^2 = 0.7 \text{ kpsi}\end{aligned}$ <p><i>Step 3.</i> From Eq. (4.29), the minimum radial stress is zero.</p> $\sigma_r^{\min} = 0 \text{ kpsi}$ <p><i>Step 4.</i> Display the stresses found in steps 1, 2, and 3, in kpsi, on the <i>edge</i> view of the stress element shown in Fig. 4.26.</p>	<p>solution</p> <p><i>Step 1.</i> Calculate the maximum shear stress using Eq. (4.22).</p> $\begin{aligned}\tau_{\max} &= \frac{2Tr_o}{\pi (r_o^4 - R^4)} \\ &= \frac{2(9,000 \text{ N} \cdot \text{m})(0.1 \text{ m})}{\pi ((0.1 \text{ m})^4 - (0.02 \text{ m})^4)} \\ &= \frac{1,800 \text{ N} \cdot \text{m}^2}{0.000314 \text{ m}^4} \\ &= 5,740,000 \text{ N/m}^2 = 5.74 \text{ MPa}\end{aligned}$ <p><i>Step 2.</i> Calculate the minimum tangential stress using Eq. (4.28).</p> $\begin{aligned}\sigma_t^{\min} &= \frac{2pR^2}{r_o^2 - R^2} \\ &= \frac{2(48,680,000 \text{ N/m}^2)(0.02 \text{ m})^2}{(0.1 \text{ m})^2 - (0.02 \text{ m})^2} \\ &= \frac{38,944 \text{ N}}{0.0096 \text{ m}^2} \\ &= 4,057,000 \text{ N/m}^2 = 4.06 \text{ MPa}\end{aligned}$ <p><i>Step 3.</i> From Eq. (4.29), the minimum radial stress is zero.</p> $\sigma_r^{\min} = 0 \text{ MPa}$ <p><i>Step 4.</i> Display the stresses found in steps 1, 2, and 3, in MPa, on the <i>edge</i> view of the stress element shown in Fig. 4.26.</p>
 <p style="text-align: center;">Edge view</p>	 <p style="text-align: center;">Edge view</p>

U.S. Customary	SI/Metric
<p><i>Step 5.</i> Display the stresses found in steps 1, 2, and 3, in kpsi, on the <i>plan</i> view of the stress element shown in Fig. 4.26.</p>  <p style="text-align: center;">Plan view</p>	<p><i>Step 5.</i> Display the stresses found in steps 1, 2, and 3, in MPa, on the <i>plan</i> view of the stress element shown in Fig. 4.26.</p>  <p style="text-align: center;">Plan view</p>
<p>Example 10. Determine the stresses on the element in Fig. 4.27 using the dimensions of the spur gear and shaft assembly in Example 8, the interface pressure (P) found, and a torque applied to the gear at the outside radius equal to</p> $T = 6,000 \text{ ft} \cdot \text{lb} = 72,000 \text{ in} \cdot \text{lb}$ $R = 0.75 \text{ in}$ $r_o = 4 \text{ in}$ $p = 9,650 \text{ lb/in}^2$ <p>solution</p> <p><i>Step 1.</i> Calculate the minimum shear stress using Eq. (4.23).</p> $\begin{aligned} \tau_{\min} &= \frac{2TR}{\pi(r_o^4 - R^4)} \\ &= \frac{2(72,000 \text{ in} \cdot \text{lb})(0.75 \text{ in})}{\pi((4 \text{ in})^4 - (0.75 \text{ in})^4)} \\ &= \frac{108,000 \text{ lb} \cdot \text{in}^2}{803 \text{ in}^4} \\ &= 134.5 \text{ lb/in}^2 = 0.13 \text{ kpsi} \end{aligned}$	<p>Example 10. Determine the stresses on the element in Fig. 4.27 using the dimensions of the spur gear and shaft assembly in Example 8, the interface pressure (P) found, and a torque applied to the gear at the outside radius equal to</p> $T = 9,000 \text{ N} \cdot \text{m}$ $R = 2 \text{ cm} = 0.02 \text{ m}$ $r_o = 10 \text{ cm} = 0.1 \text{ m}$ $p = 48,680,000 \text{ N/m}^2$ <p>solution</p> <p><i>Step 1.</i> Calculate the maximum shear stress using Eq. (4.23).</p> $\begin{aligned} \tau_{\min} &= \frac{2TR}{\pi(r_o^4 - R^4)} \\ &= \frac{2(9,000 \text{ N} \cdot \text{m})(0.02 \text{ m})}{\pi((0.1 \text{ m})^4 - (0.02 \text{ m})^4)} \\ &= \frac{360 \text{ N} \cdot \text{m}^2}{0.000314 \text{ m}^4} \\ &= 1,146,500 \text{ N/m}^2 = 1.15 \text{ MPa} \end{aligned}$

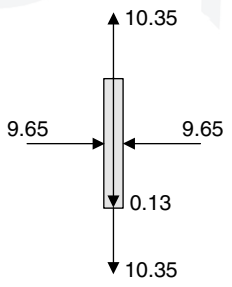
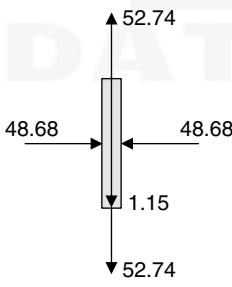
U.S. Customary	SI/Metric
<p><i>Step 2.</i> Calculate the maximum tangential stress using Eq. (4.26).</p> $\begin{aligned}\sigma_t^{\max} &= p \left[\frac{r_o^2 + R^2}{r_o^2 - R^2} \right] \\ &= (9,650 \text{ lb/in}^2) \\ &\quad \times \left[\frac{(4 \text{ in})^2 + (0.75 \text{ in})^2}{(4 \text{ in})^2 - (0.75 \text{ in})^2} \right] \\ &= (9,650 \text{ lb/in}^2) \\ &\quad \times \left[\frac{(16 + 0.5625) \text{ in}^2}{(16 - 0.5625) \text{ in}^2} \right] \\ &= (9,650 \text{ lb/in}^2) \\ &\quad \times \left[\frac{(16.5625) \text{ in}^2}{(15.4375) \text{ in}^2} \right] \\ &= (9,650 \text{ lb/in}^2)[1.073] \\ &= 10,353 \text{ lb/in}^2 = 10.35 \text{ kpsi}\end{aligned}$	<p><i>Step 2.</i> Calculate the maximum tangential stress using Eq. (4.26).</p> $\begin{aligned}\sigma_t^{\max} &= p \left[\frac{r_o^2 + R^2}{r_o^2 - R^2} \right] \\ &= (48,680,000 \text{ N/m}^2) \\ &\quad \times \left[\frac{(0.1 \text{ m})^2 + (0.02 \text{ m})^2}{(0.1 \text{ m})^2 - (0.02 \text{ m})^2} \right] \\ &= (48,680,000 \text{ N/m}^2) \\ &\quad \times \left[\frac{(0.01 + 0.0004) \text{ m}^2}{(0.01 - 0.0004) \text{ m}^2} \right] \\ &= (48,680,000 \text{ N/m}^2) \\ &\quad \times \left[\frac{(0.0104) \text{ m}^2}{(0.0096) \text{ m}^2} \right] \\ &= (48,680,000 \text{ N/m}^2)[1.083] \\ &= 52,737,000 \text{ N/m}^2 = 52.74 \text{ MPa}\end{aligned}$
<p><i>Step 3.</i> From Eq. (4.27) the maximum radial stress is</p> $\begin{aligned}\sigma_r^{\max} &= -p = -9,650 \text{ lb/in}^2 \\ &= -9.65 \text{ kpsi}\end{aligned}$	<p><i>Step 3.</i> From Eq. (4.27) the maximum radial stress is</p> $\begin{aligned}\sigma_r^{\max} &= -p = -48,680,000 \text{ N/m}^2 \\ &= -48.68 \text{ MPa}\end{aligned}$
<p><i>Step 4.</i> Display the stresses found in steps 1, 2, and 3, in kpsi, on the <i>edge</i> view of the stress element shown in Fig. 4.27.</p>	<p><i>Step 4.</i> Display the stresses found in steps 1, 2, and 3, in MPa, on the <i>edge</i> view of the stress element shown in Fig. 4.27.</p>
 <p style="text-align: center;">Edge view</p>	 <p style="text-align: center;">Edge view</p>

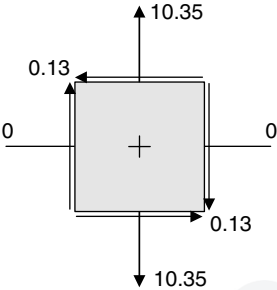
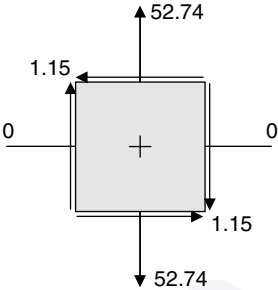
U.S. Customary	SI/Metric
<p><i>Step 5.</i> Display the stresses found in steps 1, 2, and 3, in kpsi, on the <i>plan</i> view of the stress element shown in Fig. 4.27.</p>  <p style="text-align: center;">Plan view</p>	<p><i>Step 5.</i> Display the stresses found in steps 1, 2, and 3, in MPa, on the <i>plan</i> view of the stress element shown in Fig. 4.27.</p>  <p style="text-align: center;">Plan view</p>

From the magnitudes of the stresses calculated in Examples 9 and 10, the stress element at the interface radius (R) has the maximum stresses. Note that the stress element at the interface radius is not a plane stress element due to the presence of the radial stress acting perpendicular to the top and the bottom surfaces. More will be said about this kind of stress element in the next chapter.

Also notice that even though a negative value was obtained for the radial stress, the negative sign is accounted for in the direction shown on the stress element.

Consider one last combination of loadings from Tables 4.1 and 4.2, bending and pressure.

4.8 BENDING AND PRESSURE

The seventh and last combination of loadings to be considered is bending and pressure. This type of loading occurs when a large pressurized tank is supported near its ends like the cylindrical tank, with hemispherical endcaps, shown in Fig. 4.28.

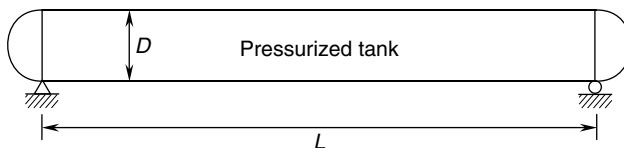

FIGURE 4.28 Bending and pressure loading.

Pressurized tanks are usually thin-walled vessels, as the wall thickness is much smaller than the diameter (D). Therefore, the internal pressure (p_i) produces an axial stress (σ_{axial}) longitudinally along the tank and given by Eq. (4.30),

$$\sigma_{\text{axial}} = \frac{p_i r_m}{2t} \quad (4.30)$$

and a hoop stress (σ_{hoop}) circumferentially around the tank and given by Eq. (4.31),

$$\sigma_{\text{hoop}} = \frac{p_i r_m}{t} = 2 \sigma_{\text{axial}} \quad (4.31)$$

which is twice the axial stress, and where (r_m) is the mean radius and (t) is the wall thickness of the tank. The mean radius (r_m) can be taken to be the inside radius of the tank without any loss of accuracy.

The tank in Fig. 4.28 can be modeled as the simply-supported beam with a constant distributed load (w) and a length (L) shown in Fig. 4.29. As will be presented in Chap. 2 on beams, this beam configuration and loading produces a bending moment (M) distribution that is maximum at its midpoint and zero at the supports, and a shear force (V) distribution that is zero at the midpoint but a maximum at the supports.

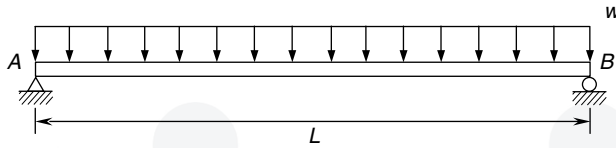

FIGURE 4.29 Simply-supported beam with constant distributed load.

The bending moment (M) will produce a bending stress (σ_{xx}) given by Eq. (4.32),

$$\sigma_{xx} = \frac{My}{I} \quad (4.32)$$

and the shear force (V) will produce a shear stress (τ_{xy}) given by Eq. (4.33),

$$\tau_{xy} = \frac{VQ}{Ib} \quad (4.33)$$

where (b) is the thickness (t) and the moment of inertia (I) is given by Eq. (4.34),

$$I = \pi r_m^3 t \quad (4.34)$$

Location of the Maximum Stress Elements. Figure 4.30 shows the cross section of the pressurized tank in Fig. 4.28 with two special stress elements identified, one at the top and one at the bottom.

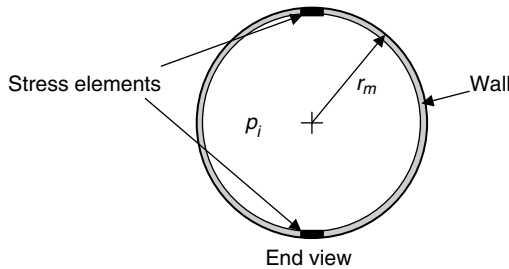

FIGURE 4.30 Elements for maximum stress.

The elements in Fig. 4.30 are for maximum bending stress (σ_{max}) that occurs where the bending moment (M) is maximum, which as stated earlier is at the midpoint between the

supports of the tank. For the simply-supported beam with a constant distributed load (w) in Fig. 4.29, the idealized model for the pressurized tank, the maximum bending moment (M_{\max}) is given by Eq. (4.35).

$$M_{\max} = \frac{1}{8} wL^2 \tag{4.35}$$

For other beam configurations and loadings, the maximum bending moment and maximum shear force, and their locations along the beam, will be different. A complete discussion of the most common beam configurations and loadings is presented in Chap. 2. Just to be complete here, the maximum shear force (V_{\max}) occurs at the supports and is given in Eq. (4.36).

$$V_{\max} = \frac{1}{2} wL \tag{4.36}$$

For this beam configuration and loading, the minimum bending moment (M_{\min}), which is zero, occurs at the supports, and the minimum shear force (V_{\min}), also zero, occurs at the midpoint between the supports.

The maximum bending stress (σ_{\max}) can be found from Eq. (4.32), where for a thin circular ring the maximum distance (y_{\max}) from the neutral axis is the mean radius (r_m) and the moment of inertia (I) is given by Eq. (4.34). The expression for maximum bending stress (σ_{\max}) is developed in Eq. (4.37).

$$\sigma_{\max} = \frac{M_{\max} y_{\max}}{I} = \frac{M_{\max} r_m}{\pi r_m^3 t} = \frac{M_{\max}}{\pi r_m^2 t} \tag{4.37}$$

where the maximum bending moment (M_{\max}) is given by Eq. (4.35).

Stress Element. The general stress element shown in Fig. 4.2 becomes the stress element shown in Fig. 4.31, where the normal stress (σ_{xx}) is a combination of the axial stress given by Eq. (4.30) and the bending stress given by Eq. (4.37), the normal stress (σ_{yy}) is the hoop stress given by Eq. (4.31), and the shear stress (τ_{xy}) is zero. Because there is no shear stress, this is a biaxial stress element.

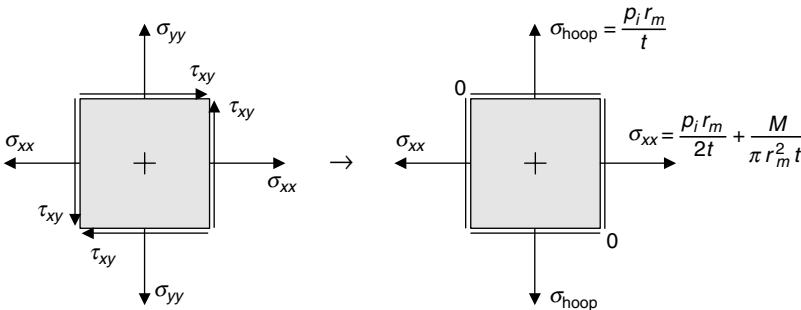

FIGURE 4.31 Stress element for bending and pressure.

The stress element shown in Fig. 4.31 is actually a view looking up at the bottom element with the axis of the tank horizontal. A better view is the *edge* view as shown in Fig. 4.32.

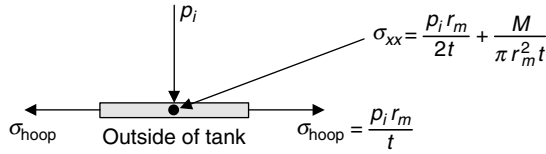
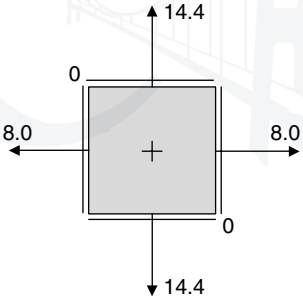
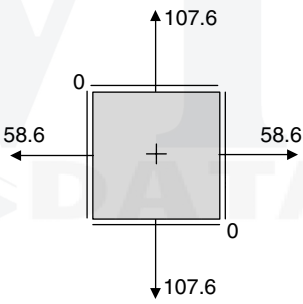
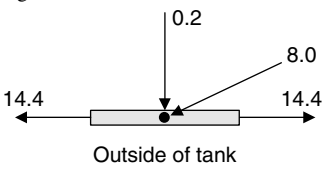
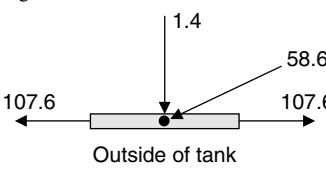

FIGURE 4.32 Edge view of bottom stress element.

The normal stress (σ_{xx}) is shown as just a dot in Fig. 4.32 as it is directed outward and perpendicular to the edge of the stress element. Also, as the internal pressure (p_i) acts on the inside surface of the element this is not a plane stress element.

U.S. Customary	SI/Metric
<p>Example 11. Determine the stresses on the bottom element shown in Fig. 4.31 for the pressurized tank in Fig. 4.28, modeled by the simply-supported beam in Fig. 4.29, where</p> <p> $p_i = 200 \text{ lb/in}^2 = 0.2 \text{ kpsi}$ $D = 6 \text{ ft} = 72 \text{ in} = 2 r_m$ $t = 0.5 \text{ in}$ $w = 1,800 \text{ lb/ft}$ $L = 24 \text{ ft}$ </p> <p>solution</p> <p><i>Step 1.</i> Calculate the axial stress (σ_{axial}) due to the internal pressure (p_i) using Eq. (4.30).</p> $\sigma_{axial} = \frac{p_i r_m}{2t} = \frac{(200 \text{ lb/in}^2)(36 \text{ in})}{2(0.5 \text{ in})}$ $= \frac{7,200 \text{ lb/in}}{1 \text{ in}}$ $= 7,200 \text{ lb/in}^2 = 7.2 \text{ kpsi}$ <p><i>Step 2.</i> Calculate the hoop stress (σ_{hoop}) due to the internal pressure (p_i) using Eq. (4.31), or use the fact that the hoop stress is twice the axial stress</p> $\sigma_{hoop} = 2 \sigma_{axial}$ $= 2(7.2 \text{ kpsi})$ $= 14.4 \text{ kpsi}$ <p><i>Step 3.</i> Calculate the maximum bending moment from Eq. (4.35).</p> $M_{max} = \frac{1}{8} wL^2$ $= \frac{1}{8} (1,800 \text{ lb/ft})(24 \text{ ft})^2$ $= 129,000 \text{ lb} \cdot \text{ft}$	<p>Example 11. Determine the stresses on the bottom element shown in Fig. 4.31 for the pressurized tank in Fig. 4.28, modeled by the simply-supported beam in Fig. 4.29, where</p> <p> $p_i = 1,400,000 \text{ N/m}^2 = 1.4 \text{ MPa}$ $D = 2 \text{ m} = 2 r_m$ $t = 1.3 \text{ cm} = 0.013 \text{ m}$ $w = 24,300 \text{ N/m}$ $L = 8 \text{ m}$ </p> <p>solution</p> <p><i>Step 1.</i> Calculate the axial stress (σ_{axial}) due to the internal pressure (p_i) using Eq. (4.30).</p> $\sigma_{axial} = \frac{p_i r_m}{2t} = \frac{(1,400,000 \text{ N/m}^2)(1 \text{ m})}{2(0.013 \text{ m})}$ $= \frac{1,400,000 \text{ N/m}}{0.026 \text{ m}}$ $= 53,846,000 \text{ N/m}^2 = 53.8 \text{ MPa}$ <p><i>Step 2.</i> Calculate the hoop stress (σ_{hoop}) due to the internal pressure (p_i) using Eq. (4.31), or use the fact that the hoop stress is twice the axial stress.</p> $\sigma_{hoop} = 2 \sigma_{axial}$ $= 2(53.8 \text{ MPa})$ $= 107.6 \text{ MPa}$ <p><i>Step 3.</i> Calculate the maximum bending moment from Eq. (4.35).</p> $M_{max} = \frac{1}{8} wL^2$ $= \frac{1}{8} (24,300 \text{ N/m})(8 \text{ m})^2$ $= 194,400 \text{ N} \cdot \text{m}$

U.S. Customary	SI/Metric
<p><i>Step 4.</i> Using the maximum bending moment (M_{\max}) found in step 3 calculate the maximum bending stress (σ_{\max}) from Eq. (4.37).</p>	<p><i>Step 4.</i> Using the maximum bending moment (M_{\max}) found in step 3 calculate the maximum bending stress (σ_{\max}) from Eq. (4.37).</p>
$\begin{aligned}\sigma_{\max} &= \frac{M_{\max}}{\pi r_m^2 t} \\ &= \frac{(129,000 \text{ lb} \cdot \text{ft}) (12 \text{ in/ft})}{\pi (36 \text{ in})^2 (0.5 \text{ in})} \\ &= \frac{1,548,000 \text{ lb} \cdot \text{in}}{2036 \text{ in}^3} \\ &= 760 \text{ lb/in}^2 = 0.8 \text{ kpsi}\end{aligned}$	$\begin{aligned}\sigma_{\max} &= \frac{M_{\max}}{\pi r_m^2 t} \\ &= \frac{(194,000 \text{ N} \cdot \text{m})}{\pi (1 \text{ m})^2 (0.013 \text{ m})} \\ &= \frac{194,000 \text{ N} \cdot \text{m}}{0.0408 \text{ m}^3} \\ &= 4,750,000 \text{ N/m}^2 = 4.8 \text{ MPa}\end{aligned}$
<p><i>Step 5.</i> Combine the axial stress (σ_{axial}) found in step 1 with the maximum bending stress (σ_{\max}) found in step 4 to give a maximum normal stress (σ_{xx}).</p>	<p><i>Step 5.</i> Combine the axial stress (σ_{axial}) found in step 1 with the maximum bending stress (σ_{\max}) found in step 4 to give a maximum normal stress (σ_{xx}).</p>
$\begin{aligned}\sigma_{xx} &= \sigma_{\text{axial}} + \sigma_{\max} \\ &= (7.2 \text{ kpsi}) + (0.8 \text{ kpsi}) \\ &= 8.0 \text{ kpsi}\end{aligned}$	$\begin{aligned}\sigma_{xx} &= \sigma_{\text{axial}} + \sigma_{\max} \\ &= (53.8 \text{ kpsi}) + (4.8 \text{ kpsi}) \\ &= 58.6 \text{ kpsi}\end{aligned}$
<p><i>Step 6.</i> Display the stresses found in steps 2 and 5, in kpsi, on the stress element shown in Fig. 4.31.</p>	<p><i>Step 6.</i> Display the stresses found in steps 2 and 5, in MPa, on the stress element shown in Fig. 4.31.</p>
	
<p><i>Step 7.</i> Display the stresses found in steps 2 and 5, in kpsi, on the stress element shown in Fig. 4.32.</p>	<p><i>Step 7.</i> Display the stresses found in steps 2 and 5, in MPa, on the stress element shown in Fig. 4.32.</p>
 <p style="text-align: center;">Outside of tank</p>	 <p style="text-align: center;">Outside of tank</p>

CHAPTER 5

PRINCIPAL STRESSES AND MOHR'S CIRCLE

5.1 INTRODUCTION

In Chap. 4, seven different combinations of loadings were discussed with each resulting in a particular stress element based on a general plane stress element, like the one shown in Fig. 4.2 and repeated here in Fig. 5.1.

The standard notation and sign conventions on both normal (σ) and shear (τ) stresses are shown in Fig. 5.1, where the normal stresses (σ_{xx}) and (σ_{yy}) are positive directed outward from the edges of the element. Therefore, the pressure (p_i) acting at right angles toward the plane of the element is a negative stress.

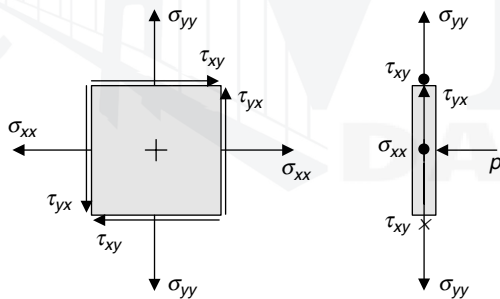

FIGURE 5.1 Plane stress element.

Each of the four shear stresses (τ_{xy}) are shown positive in Fig. 5.1; however, some references have been shown in the opposite direction. Either is correct.

Some loading combinations, typically those involving pressure, such as the internal pressure (p_i) in Fig. 5.1, result in stresses that are not all in a plane. Although not true plane stress elements, they will be handled easily by the process that follows.

Although it might not have been obvious at the time, all the elements in Chap. 4 were aligned along the natural directions of the problem. However, the stresses that resulted are not the *absolute* maximum stresses the material will be subjected to.

5.2 PRINCIPAL STRESSES

Suppose the element in Fig. 5.1 that is assumed to be aligned along some natural direction of a machine, such as the center of a shaft, or thick-walled cylinder, or along the axis of a beam that is modeling the machine, is rotated counterclockwise an angle (θ). A new set of normal and shear stresses will act on the plane stress element. This rotated element is shown in Fig. 5.2, where the new coordinate axes and stresses are denoted by *primes* and labeled $(\sigma_{x'x'})$, $(\sigma_{y'y'})$, and $(\tau_{x'y'})$.

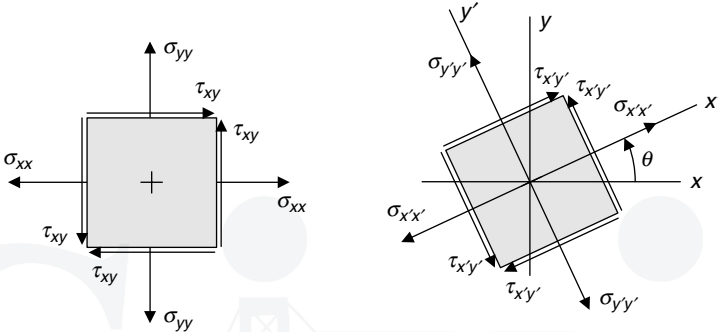

FIGURE 5.2 Rotated plane stress element.

If all the stresses in Fig. 5.2 are multiplied by the appropriate area over which each acts, a set of forces acting on the rotated and unrotated elements will result. Furthermore, if equilibrium is to be satisfied for both the rotated and unrotated elements, then a set of relationships can be established between the rotated and unrotated stresses. Leaving out the development with its billion algebra and trig steps, these relationships between the rotated and unrotated stresses are given in the following three equations:

$$\sigma_{x'x'} = \frac{\sigma_{xx} + \sigma_{yy}}{2} + \frac{\sigma_{xx} - \sigma_{yy}}{2} \cos 2\theta + \tau_{xy} \sin 2\theta \tag{5.1}$$

$$\sigma_{y'y'} = \frac{\sigma_{xx} + \sigma_{yy}}{2} - \frac{\sigma_{xx} - \sigma_{yy}}{2} \cos 2\theta - \tau_{xy} \sin 2\theta \tag{5.2}$$

$$\tau_{x'y'} = -\frac{\sigma_{xx} - \sigma_{yy}}{2} \sin 2\theta + \tau_{xy} \cos 2\theta \tag{5.3}$$

Consider the following manufacturing process to see how these relationships provide important design information.

One of the ways thin-walled cylindrical pressure vessels are manufactured is by passing steel plate through a set of compression rollers creating a circular piece of steel that can then be welded along the resulting seams. Such a vessel is shown in Fig. 5.3.

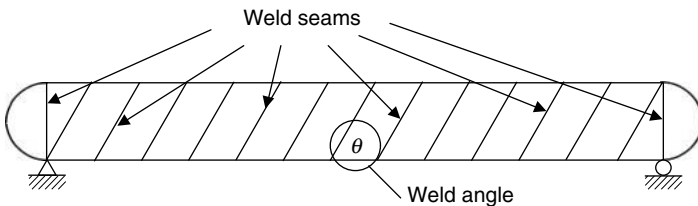

FIGURE 5.3 Welded cylindrical pressure vessel.

The angle (θ) in Fig. 5.3 is the weld angle and it is the stresses relative to this angle that are most important to the design engineer. However, it is the stresses relative to the natural axis of the cylinder that are found first, using the equations presented in Sec. 3.1.1. Then Eqs. (5.1) to (5.3) are used to find the stresses along the direction defined by the angle (θ).

For the thin-walled cylindrical pressure vessel shown in Fig. 5.4,

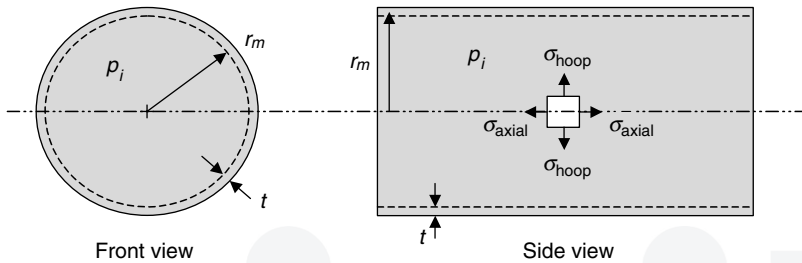

FIGURE 5.4 Cylindrical pressure vessel.

which was first presented in Sec. 3.1.1, the axial stress (σ_{axial}) in the wall of the cylinder is given by Eq. (5.4),

$$\sigma_{\text{axial}} = \frac{p_i r_m}{2t} \quad (5.4)$$

and the hoop stress (σ_{hoop}) in the wall of the cylinder is given by Eq. (5.5),

$$\sigma_{\text{hoop}} = \frac{p_i r_m}{t} \quad (5.5)$$

where p_i = internal gage pressure (meaning above atmospheric pressure)
 r_m = mean radius (can be assumed to be inside radius of cylinder)
 t = wall thickness

Notice that the hoop stress (σ_{hoop}) is twice the axial stress (σ_{axial}). Also notice that the stress element in Fig. 5.4 is a biaxial stress element, meaning there is no shear stress on the element. However, remember that the pressure (p_i) acts on the inside of the stress element, so it is not a true plane stress element, but this is alright for the analysis.

U.S. Customary	SI/Metric
<p>Example 1. Determine the stresses on an element of the cylinder oriented along the welds of the cylindrical tank shown in Fig. 5.3, where</p> <p>$\theta = 60$ degrees $p_i = 100 \text{ lb/in}^2 = 0.1 \text{ kpsi}$ $D = 4 \text{ ft} = 48 \text{ in} = 2r_m$ $t = 0.25 \text{ in}$</p>	<p>Example 1. Determine the stresses on an element of the cylinder oriented along the welds of the cylindrical tank shown in Fig. 5.3, where</p> <p>$\theta = 60$ degrees $p_i = 700,000 \text{ N/m}^2 = 0.7 \text{ MPa}$ $D = 1.4 \text{ m} = 2r_m$ $t = 0.65 \text{ cm} = 0.0065 \text{ m}$</p>

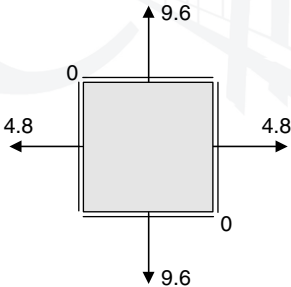
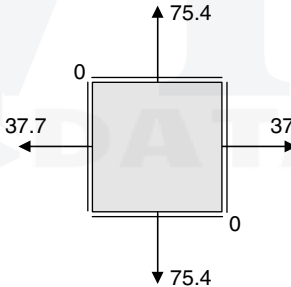
U.S. Customary	SI/Metric
<p>solution</p> <p><i>Step 1.</i> Calculate the axial stress (σ_{axial}) due to the internal pressure (p_i) using Eq. (5.4).</p> $\sigma_{\text{axial}} = \frac{p_i r_m}{2t} = \frac{(100 \text{ lb/in}^2)(24 \text{ in})}{2(0.25 \text{ in})}$ $= \frac{2,400 \text{ lb/in}}{0.5 \text{ in}}$ $= 4,800 \text{ lb/in}^2 = 4.8 \text{ kpsi}$ <p><i>Step 2.</i> Calculate the hoop stress (σ_{hoop}) due to the internal pressure (p_i) using Eq. (5.5), or use the fact that the hoop stress is twice the axial stress.</p> $\sigma_{\text{hoop}} = 2\sigma_{\text{axial}}$ $= 2(4.8 \text{ kpsi})$ $= 9.6 \text{ kpsi}$ <p><i>Step 3.</i> Display the answers for the axial stress (σ_{axial}) found in step 1 and the hoop stress (σ_{hoop}) found in step 2, in kpsi, on the element of Fig. 5.4.</p>  <p><i>Step 4.</i> Using Eq. (5.1), calculate the rotated stress ($\sigma_{x'x'}$) where from step 3 the unrotated stresses are</p> $\sigma_{xx} = \sigma_{\text{axial}} = 4.8 \text{ kpsi}$ $\sigma_{yy} = \sigma_{\text{hoop}} = 9.6 \text{ kpsi}$ $\tau_{xy} = 0$	<p>solution</p> <p><i>Step 1.</i> Calculate the axial stress (σ_{axial}) due to the internal pressure (p_i) using Eq. (5.4).</p> $\sigma_{\text{axial}} = \frac{p_i r_m}{2t} = \frac{(700,000 \text{ N/m}^2)(0.7 \text{ m})}{2(0.0065 \text{ m})}$ $= \frac{490,000 \text{ N/m}}{0.013 \text{ m}}$ $= 37,700,000 \text{ N/m}^2 = 37.7 \text{ MPa}$ <p><i>Step 2.</i> Calculate the hoop stress (σ_{hoop}) due to the internal pressure (p_i) using Eq. (5.5), or use the fact that the hoop stress is twice the axial stress.</p> $\sigma_{\text{hoop}} = 2\sigma_{\text{axial}}$ $= 2(37.7 \text{ MPa})$ $= 75.4 \text{ MPa}$ <p><i>Step 3.</i> Display the answers for the axial stress (σ_{axial}) found in step 1 and the hoop stress (σ_{hoop}) found in step 2, in kpsi, on the element of Fig. 5.4.</p>  <p><i>Step 4.</i> Using Eq. (5.1), calculate the rotated stress ($\sigma_{x'x'}$) where from step 3 the unrotated stresses are</p> $\sigma_{xx} = \sigma_{\text{axial}} = 37.7 \text{ MPa}$ $\sigma_{yy} = \sigma_{\text{hoop}} = 75.4 \text{ MPa}$ $\tau_{xy} = 0$

U.S. Customary	SI/Metric
$\begin{aligned}\sigma_{x'x'} &= \frac{\sigma_{xx} + \sigma_{yy}}{2} + \frac{\sigma_{xx} - \sigma_{yy}}{2} \cos 2\theta \\ &\quad + \tau_{xy} \sin 2\theta \\ &= \frac{(4.8 + 9.6) \text{ kpsi}}{2} \\ &\quad + \frac{(4.8 - 9.6) \text{ kpsi}}{2} \cos 2(60^\circ) \\ &\quad + (0 \text{ kpsi}) \sin 2(60^\circ) \\ &= \frac{(14.4 \text{ kpsi})}{2} \\ &\quad + \frac{(-4.8 \text{ kpsi})}{2} \cos (120^\circ) \\ &\quad + (0 \text{ kpsi}) \sin (120^\circ) \\ &= (7.2 \text{ kpsi}) \\ &\quad + (-2.4 \text{ kpsi}) (-0.5) \\ &\quad + (0 \text{ kpsi}) \\ &= (7.2 + 1.2 + 0) \text{ kpsi} \\ &= 8.4 \text{ kpsi}\end{aligned}$ <p><i>Step 5.</i> Similarly, using Eq. (5.2), calculate the rotated stress ($\sigma_{y'y'}$) from the unrotated stresses given in step 4.</p> $\begin{aligned}\sigma_{y'y'} &= \frac{\sigma_{xx} + \sigma_{yy}}{2} - \frac{\sigma_{xx} - \sigma_{yy}}{2} \cos 2\theta \\ &\quad - \tau_{xy} \sin 2\theta \\ &= \frac{(4.8 + 9.6) \text{ kpsi}}{2} \\ &\quad - \frac{(4.8 - 9.6) \text{ kpsi}}{2} \cos 2(60^\circ) \\ &\quad - (0 \text{ kpsi}) \sin 2(60^\circ) \\ &= \frac{(14.4 \text{ kpsi})}{2} \\ &\quad - \frac{(-4.8 \text{ kpsi})}{2} \cos (120^\circ) \\ &\quad - (0 \text{ kpsi}) \sin (120^\circ) \\ &= (7.2 \text{ kpsi}) \\ &\quad - (-2.4 \text{ kpsi}) (-0.5) \\ &\quad - (0 \text{ kpsi}) \\ &= (7.2 - 1.2 - 0) \text{ kpsi} \\ &= 6.0 \text{ kpsi}\end{aligned}$	$\begin{aligned}\sigma_{x'x'} &= \frac{\sigma_{xx} + \sigma_{yy}}{2} + \frac{\sigma_{xx} - \sigma_{yy}}{2} \cos 2\theta \\ &\quad + \tau_{xy} \sin 2\theta \\ &= \frac{(37.7 + 75.4) \text{ MPa}}{2} \\ &\quad + \frac{(37.7 - 75.4) \text{ MPa}}{2} \cos 2(60^\circ) \\ &\quad + (0 \text{ MPa}) \sin 2(60^\circ) \\ &= \frac{(113.1 \text{ MPa})}{2} \\ &\quad + \frac{(-37.7 \text{ MPa})}{2} \cos (120^\circ) \\ &\quad + (0 \text{ MPa}) \sin (120^\circ) \\ &= (56.55 \text{ MPa}) \\ &\quad + (-18.85 \text{ MPa}) (-0.5) \\ &\quad + (0 \text{ MPa}) \\ &= (56.55 + 9.43 + 0) \text{ MPa} \\ &= 66.0 \text{ MPa}\end{aligned}$ <p><i>Step 5.</i> Similarly, using Eq. (5.2), calculate the rotated stress ($\sigma_{y'y'}$) from the unrotated stresses given in step 4.</p> $\begin{aligned}\sigma_{y'y'} &= \frac{\sigma_{xx} + \sigma_{yy}}{2} - \frac{\sigma_{xx} - \sigma_{yy}}{2} \cos 2\theta \\ &\quad - \tau_{xy} \sin 2\theta \\ &= \frac{(37.7 + 75.4) \text{ MPa}}{2} \\ &\quad - \frac{(37.7 - 75.4) \text{ MPa}}{2} \cos 2(60^\circ) \\ &\quad - (0 \text{ MPa}) \sin 2(60^\circ) \\ &= \frac{(113.1 \text{ MPa})}{2} \\ &\quad - \frac{(-37.7 \text{ MPa})}{2} \cos (120^\circ) \\ &\quad - (0 \text{ MPa}) \sin (120^\circ) \\ &= (56.55 \text{ MPa}) \\ &\quad - (-18.85 \text{ MPa}) (-0.5) \\ &\quad - (0 \text{ MPa}) \\ &= (56.55 - 9.43 - 0) \text{ MPa} \\ &= 47.1 \text{ MPa}\end{aligned}$

U.S. Customary	SI/Metric
<p><i>Step 6.</i> Similarly, using Eq. (5.3), calculate the rotated stress ($\tau_{x'y'}$) from the unrotated stresses given in step 4.</p> $\begin{aligned} \tau_{x'y'} &= -\frac{\sigma_{xx} - \sigma_{yy}}{2} \sin 2\theta + \tau_{xy} \cos 2\theta \\ &= -\frac{(4.8 - 9.6) \text{ kpsi}}{2} \sin 2(60^\circ) \\ &\quad + (0 \text{ kpsi}) \cos 2(60^\circ) \\ &= -\frac{(-4.8 \text{ kpsi})}{2} \sin (120^\circ) \\ &\quad + (0 \text{ kpsi}) \cos (120^\circ) \\ &= -(-2.4 \text{ kpsi}) (0.866) + (0 \text{ kpsi}) \\ &= (2.08 + 0) \text{ kpsi} \\ &= 2.1 \text{ kpsi} \end{aligned}$ <p><i>Step 7.</i> Display the rotated stresses found in steps 4, 5, and 6, in kpsi, on the rotated element of Fig. 5.2.</p>	<p><i>Step 6.</i> Similarly, using Eq. (5.3), calculate the rotated stress ($\tau_{x'y'}$) from the unrotated stresses given in step 4.</p> $\begin{aligned} \tau_{x'y'} &= -\frac{\sigma_{xx} - \sigma_{yy}}{2} \sin 2\theta + \tau_{xy} \cos 2\theta \\ &= -\frac{(37.7 - 75.4) \text{ MPa}}{2} \sin 2(60^\circ) \\ &\quad - (0 \text{ MPa}) \cos 2(60^\circ) \\ &= -\frac{(-37.7 \text{ MPa})}{2} \sin (120^\circ) \\ &\quad - (0 \text{ MPa}) \cos (120^\circ) \\ &= -(-18.85 \text{ MPa}) (0.866) - (0 \text{ MPa}) \\ &= (16.32 - 0) \text{ MPa} \\ &= 16.3 \text{ MPa} \end{aligned}$ <p><i>Step 7.</i> Display the rotated stresses found in steps 4 to 6, in MPa, on the rotated element of Fig. 5.2.</p>

As a check on the calculations involved in applying Eqs. (5.1) to (5.3), like that in Example 1, the following relationship given by Eq. (5.6) must always be satisfied between two sets of stresses at different rotation angles (θ).

$$\sigma_{x'x'} + \sigma_{y'y'} = \sigma_{xx} + \sigma_{yy} \tag{5.6}$$

U.S. Customary	SI/Metric
<p>Example 2. Verify that the values for the unrotated and rotated normal stresses of Example 1 satisfy Eq. (5.6), where</p> $\begin{aligned} \sigma_{x'x'} + \sigma_{y'y'} &= \sigma_{xx} + \sigma_{yy} \\ (8.4 + 6.0) \text{ kpsi} &= (4.8 + 9.6) \text{ kpsi} \\ 14.4 \text{ kpsi} &\equiv 14.4 \text{ kpsi} \end{aligned}$ <p>Clearly the stresses check.</p>	<p>Example 2. Verify that the values for the unrotated and rotated normal stresses of Example 1 satisfy Eq. (5.6), where</p> $\begin{aligned} \sigma_{x'x'} + \sigma_{y'y'} &= \sigma_{xx} + \sigma_{yy} \\ (66.0 + 47.1) \text{ MPa} &= (37.7 + 75.4) \text{ MPa} \\ 113.1 \text{ MPa} &\equiv 113.1 \text{ MPa} \end{aligned}$ <p>Clearly the stresses check.</p>

The rotated stresses found in Example 1, and verified in Example 2, can now be used to design the weld joint itself. The rotated stress ($\sigma_{x'x'}$) provides the normal stress requirement along the weld, the rotated stress ($\sigma_{y'y'}$) provides the normal stress requirement perpendicular to the weld, and the rotated stress ($\tau_{x'y'}$) provides the shear stress requirement for the weld. Design of welds is not covered in this book, however *Marks' Standard Handbook for Mechanical Engineers*, as well as the *Standard Handbook of Machine Design*, are excellent references for the required analysis.

Maximum Stress Elements. If only a set of rotated stresses are needed from a known set of unrotated stresses for a specified angle (θ), like in Example 1, then Eqs. (5.1) to (5.3) are sufficient to provide this information and this section would be complete. However, what the machine designer really wants to know is what are the maximum stresses acting on the element, and it is expected that these maximum stresses will not occur at an angle (θ) equal to zero. Again, the angle (θ) represents rotation from a direction natural to the machine element under investigation. In Example 1 it was the axis of the pressurized tank. For a beam in bending it typically would be the neutral axis.

To find the maximum stresses, and the special angle of the stress element on which they act, Eqs. (5.1) to (5.3), which are only functions of the angle (θ), are differentiated with respect to the angle (θ), then these derivatives are set equal to zero to find the special angle, denoted (ϕ_p), that the unrotated element must be rotated to provide the element with the maximum values of the stresses. This special angle is then substituted in Eqs. (5.1) to (5.3) to provide the relationships required. Remember, it is assumed that the unrotated stresses, (σ_{xx}), (σ_{yy}), and (τ_{xy}) are known.

Leaving out the details of the differentiations, and the bzzillion algebra and trig steps, the maximum normal stress, called the principal stress (σ_1) is given by Eq. (5.7),

$$\sigma_1 = \frac{\sigma_{xx} + \sigma_{yy}}{2} + \sqrt{\left(\frac{\sigma_{xx} - \sigma_{yy}}{2}\right)^2 + \tau_{xy}^2} \quad (5.7)$$

and the minimum normal stress, called the principal stress (σ_2) is given by Eq. (5.8),

$$\sigma_2 = \frac{\sigma_{xx} + \sigma_{yy}}{2} - \sqrt{\left(\frac{\sigma_{xx} - \sigma_{yy}}{2}\right)^2 + \tau_{xy}^2} \quad (5.8)$$

where the special angle (ϕ_p) for the rotated element on which the principal stresses (σ_1) and (σ_2) act is given by Eq. (5.9).

$$\tan 2\phi_p = \frac{2\tau_{xy}}{\sigma_{xx} - \sigma_{yy}} \quad (5.9)$$

For the rotated element defined by the angle (ϕ_p), the shear stresses are zero.

Without providing the proof, the maximum and minimum shear stresses are on an element rotated 45 degrees from the angle (ϕ_p), denoted by (ϕ_s), and given by Eq. (5.10).

$$\tan 2\phi_s = -\frac{\sigma_{xx} - \sigma_{yy}}{2\tau_{xy}} \quad (5.10)$$

Again, without providing the proof, the relationship between the special angle (ϕ_p) for the principal stresses (σ_1) and (σ_2) and the special angle (ϕ_s) for the maximum and minimum shear stresses is given by Eq. (5.11).

$$\phi_s = \phi_p \pm 45^\circ \quad (5.11)$$

One value of (ϕ_s) gives the maximum shear stress (τ_{\max}) , and the other value of (ϕ_s) gives (τ_{\min}) . These two values of (ϕ_s) are 90 degrees apart, like the directions for the principal stresses, (σ_1) and (σ_2) , which are also 90 degrees apart.

Substituting one of the values for the angle (ϕ_s) defined by Eq. (5.10) in Eq. (5.3) gives the maximum shear stress (τ_{\max}) , given by Eq. (5.12),

$$\tau_{\max} = \sqrt{\left(\frac{\sigma_{xx} - \sigma_{yy}}{2}\right)^2 + \tau_{xy}^2} \tag{5.12}$$

and substituting the other value for the angle (ϕ_s) defined by Eq. (5.10) in Eq. (5.3) gives the minimum shear stress (τ_{\min}) , given by Eq. (5.13),

$$\tau_{\min} = -\sqrt{\left(\frac{\sigma_{xx} - \sigma_{yy}}{2}\right)^2 + \tau_{xy}^2} = -\tau_{\max} \tag{5.13}$$

which is just the negative of the maximum shear stress (τ_{\max}) .

On the rotated elements associated with the maximum and minimum shear stresses, the normal stresses will be equal, and also equal to the average stress (σ_{avg}) given by Eq. (5.14).

$$\sigma_{\text{avg}} = \frac{\sigma_{xx} + \sigma_{yy}}{2} \tag{5.14}$$

Noting that the first terms in both Eqs. (5.7) and (5.8) are the average stress (σ_{avg}) given by Eq. (5.14), and that the magnitude of the second terms are the maximum shear stress (τ_{\max}) , Eqs. (5.7) and (5.8) for the principal stresses (σ_1) and (σ_2) can be rewritten in the following forms.

$$\sigma_1 = \sigma_{\text{avg}} + \tau_{\max} \tag{5.15}$$

$$\sigma_2 = \sigma_{\text{avg}} - \tau_{\max} \tag{5.16}$$

Similar to the relationship in Eq. (5.6), the values found for the principal stresses from Eqs. (5.15) and (5.16) must satisfy the relationship in Eq. (5.17).

$$\sigma_1 + \sigma_2 = \sigma_{xx} + \sigma_{yy} \tag{5.17}$$

Before going to the next topic where the principal stresses (σ_1) and (σ_2) , the maximum and minimum shear stresses (τ_{\max}) and (τ_{\min}) , and the associated angles (ϕ_p) and (ϕ_s) , will be determined graphically using Mohr's circle, consider the following examples, which hopefully will provide an appreciation for the usefulness of the graphical approach called Mohr's circle.

U.S. Customary	SI/Metric
<p>Example 3. For the normal and shear stresses on the unrotated stress element of Example 1, find the principal stresses, maximum and minimum shear stresses, and the special angles (ϕ_p) and (ϕ_s), and display these values on appropriate rotated plane stress elements, where</p> $\begin{aligned} \sigma_{xx} &= \sigma_{\text{axial}} = 4.8 \text{ kpsi} \\ \sigma_{yy} &= \sigma_{\text{hoop}} = 9.6 \text{ kpsi} \\ \tau_{xy} &= 0 \end{aligned}$ <p>displayed on the following element.</p>	<p>Example 3. For the normal and shear stresses on the unrotated stress element of Example 1, find the principal stresses, maximum and minimum shear stresses, and the special angles (ϕ_p) and (ϕ_s), and display these values on appropriate rotated plane stress elements, where</p> $\begin{aligned} \sigma_{xx} &= \sigma_{\text{axial}} = 37.7 \text{ MPa} \\ \sigma_{yy} &= \sigma_{\text{hoop}} = 75.4 \text{ MPa} \\ \tau_{xy} &= 0 \end{aligned}$ <p>displayed on the following element.</p>

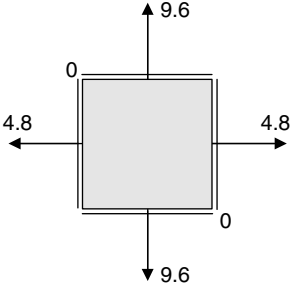
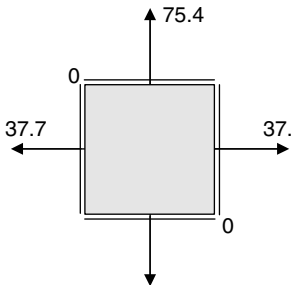
U.S. Customary	SI/Metric
	
<p>solution</p> <p><i>Step 1.</i> As the unrotated shear stress (τ_{xy}) is zero, the unrotated stress element is actually the principal stress element, except that the rotation angle (ϕ_p) is equal to ($\pm 90^\circ$), and so</p> $\sigma_1 = \sigma_{yy} = 9.6 \text{ kpsi}$ $\sigma_2 = \sigma_{xx} = 4.8 \text{ kpsi}$ <p><i>Step 2.</i> Obviously, the values for the principal stresses satisfy Eq. (5.17).</p> $\sigma_1 + \sigma_2 = \sigma_{xx} + \sigma_{yy}$ $(9.4 + 4.8) \text{ kpsi} = (4.8 + 9.6) \text{ kpsi}$ $14.4 \text{ kpsi} \equiv 14.4 \text{ kpsi}$ <p><i>Step 3.</i> Using Eq. (5.11), the rotation angle (ϕ_s) for maximum and minimum shear stress becomes</p> $\phi_s = \phi_p \pm 45^\circ$ $= \pm 90^\circ \pm 45^\circ$ $= \pm 135^\circ \text{ or } \pm 45^\circ$ <p>where the values in the first and fourth quadrants ($\pm 45^\circ$) are chosen.</p> <p><i>Step 4.</i> Using Eq. (5.12), the maximum shear stress (τ_{\max}) becomes</p> $\tau_{\max} = \sqrt{\left(\frac{\sigma_{xx} - \sigma_{yy}}{2}\right)^2 + \tau_{xy}^2}$ $= \sqrt{\left(\frac{4.8 - 9.6}{2} \text{ kpsi}\right)^2 + (0)^2}$ $= \sqrt{\left(\frac{-4.8 \text{ kpsi}}{2}\right)^2}$ $= \sqrt{(-2.4 \text{ kpsi})^2} = 2.4 \text{ kpsi}$	<p>solution</p> <p><i>Step 1.</i> As the unrotated shear stress (τ_{xy}) is zero, the unrotated stress element is actually the principal stress element, except that the rotation angle (ϕ_p) is equal to ($\pm 90^\circ$), and so</p> $\sigma_1 = \sigma_{yy} = 75.4 \text{ MPa}$ $\sigma_2 = \sigma_{xx} = 37.7 \text{ MPa}$ <p><i>Step 2.</i> Obviously, the values for the principal stresses satisfy Eq. (5.17).</p> $\sigma_1 + \sigma_2 = \sigma_{xx} + \sigma_{yy}$ $(75.4 + 37.7) \text{ MPa} = (37.7 + 75.4) \text{ MPa}$ $113.1 \text{ MPa} \equiv 113.1 \text{ MPa}$ <p><i>Step 3.</i> Using Eq. (5.11), the rotation angle (ϕ_s) for maximum and minimum shear stress becomes</p> $\phi_s = \phi_p \pm 45^\circ$ $= \pm 90^\circ \pm 45^\circ$ $= \pm 135^\circ \text{ or } \pm 45^\circ$ <p>where the values in the first and fourth quadrants ($\pm 45^\circ$) are chosen.</p> <p><i>Step 4.</i> Using Eq. (5.12), the maximum shear stress (τ_{\max}) becomes</p> $\tau_{\max} = \sqrt{\left(\frac{\sigma_{xx} - \sigma_{yy}}{2}\right)^2 + \tau_{xy}^2}$ $= \sqrt{\left(\frac{37.7 - 75.4}{2} \text{ MPa}\right)^2 + (0)^2}$ $= \sqrt{\left(\frac{-37.7 \text{ MPa}}{2}\right)^2}$ $= \sqrt{(-18.85 \text{ MPa})^2} = 18.85 \text{ MPa}$

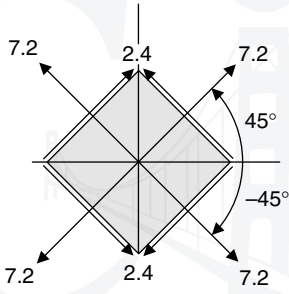
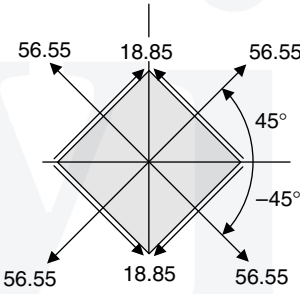
U.S. Customary	SI/Metric
<p>and so the minimum shear stress (τ_{\min}) from Eq. (5.13) is</p>	<p>and so the minimum shear stress (τ_{\min}) from Eq. (5.13) is</p>
$\tau_{\min} = -\tau_{\max} = -2.4 \text{ kpsi}$	$\tau_{\min} = -\tau_{\max} = -18.85 \text{ MPa}$
<p><i>Step 5.</i> Using Eq. (5.14), calculate the average normal stress (σ_{avg}) as</p>	<p><i>Step 5.</i> Using Eq. (5.14), calculate the average normal stress (σ_{avg}) as</p>
$\begin{aligned} \sigma_{\text{avg}} &= \frac{\sigma_{xx} + \sigma_{yy}}{2} = \frac{(4.8 + 9.6) \text{ kpsi}}{2} \\ &= \frac{14.4 \text{ kpsi}}{2} = 7.2 \text{ kpsi} \end{aligned}$	$\begin{aligned} \sigma_{\text{avg}} &= \frac{\sigma_{xx} + \sigma_{yy}}{2} = \frac{(37.7 + 75.4) \text{ MPa}}{2} \\ &= \frac{113.1 \text{ MPa}}{2} = 56.55 \text{ MPa} \end{aligned}$
<p><i>Step 6.</i> Display the maximum and minimum shear stresses found in step 4, the average stress found in step 5, and the rotation angle (ϕ_s) chosen in step 3, on a rotated element.</p>	<p><i>Step 6.</i> Display the maximum and minimum shear stresses found in step 4, the average stress found in step 5, and the rotation angle (ϕ_s) chosen in step 3, on a rotated element.</p>
	
<p><i>Step 7.</i> As a final check on the calculations, use Eq. (5.15) to find the maximum principal stress (σ_1) as</p>	<p><i>Step 7.</i> As a final check on the calculations, use Eq. (5.15) to find the maximum principal stress (σ_1) as</p>
$\begin{aligned} \sigma_1 &= \sigma_{\text{avg}} + \tau_{\max} = (7.2 + 2.4) \text{ kpsi} \\ &= 9.6 \text{ kpsi} \end{aligned}$	$\begin{aligned} \sigma_1 &= \sigma_{\text{avg}} + \tau_{\max} = (56.55 + 18.85) \text{ MPa} \\ &= 75.4 \text{ MPa} \end{aligned}$
<p>and use Eq. (5.16) to find the minimum principal stress (σ_2) as</p>	<p>and use Eq. (5.16) to find the minimum principal stress (σ_2) as</p>
$\begin{aligned} \sigma_2 &= \sigma_{\text{avg}} - \tau_{\max} = (7.2 - 2.4) \text{ kpsi} \\ &= 4.8 \text{ kpsi} \end{aligned}$	$\begin{aligned} \sigma_2 &= \sigma_{\text{avg}} - \tau_{\max} = (56.55 - 18.85) \text{ MPa} \\ &= 37.7 \text{ MPa} \end{aligned}$

In Chap. 4 on combined loadings, a statement was made at the end of most of the examples that the stress element shown would be the starting point for discussions in Chap. 5. Consider one of these elements, one which does not have the unrotated shear stress (τ_{xy}) equal to zero, nor a pressure acting on either side of the element, as was the case for Example 3.

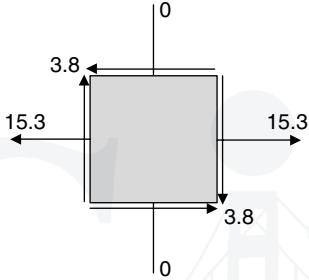
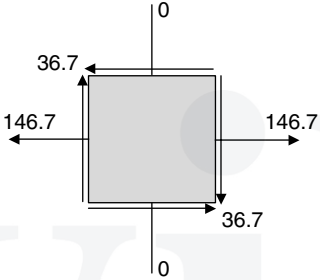
U.S. Customary	SI/Metric
<p>Example 4. For the normal and shear stresses on the unrotated <i>top</i> stress element of Example 5 in Sec. 4.4, find the principal stresses, maximum and minimum shear stresses, and the special angles (ϕ_p) and (ϕ_s), and display these values on appropriate rotated plane stress elements, where</p>	<p>Example 4. For the normal and shear stresses on the unrotated <i>top</i> stress element of Example 5 in Sec. 4.4, find the principal stresses, maximum and minimum shear stresses, and the special angles (ϕ_p) and (ϕ_s), and display these values on appropriate rotated plane stress elements, where</p>
$\begin{aligned}\sigma_{xx} &= 15.3 \text{ kpsi} \\ \sigma_{yy} &= 0 \\ \tau_{xy} &= -3.8 \text{ kpsi}\end{aligned}$	$\begin{aligned}\sigma_{xx} &= 146.7 \text{ MPa} \\ \sigma_{yy} &= 0 \\ \tau_{xy} &= -36.7 \text{ MPa}\end{aligned}$
<p>displayed in the following element:</p>	<p>displayed in the following element:</p>
	
<p>solution</p> <p><i>Step 1.</i> Calculate the average normal stress (σ_{avg}) from Eq. (5.14) as</p> $\begin{aligned}\sigma_{\text{avg}} &= \frac{\sigma_{xx} + \sigma_{yy}}{2} = \frac{(15.3 + 0) \text{ kpsi}}{2} \\ &= 7.65 \text{ kpsi}\end{aligned}$	<p>solution</p> <p><i>Step 1.</i> Calculate the average normal stress (σ_{avg}) from Eq. (5.14) as</p> $\begin{aligned}\sigma_{\text{avg}} &= \frac{\sigma_{xx} + \sigma_{yy}}{2} = \frac{(146.7 + 0) \text{ MPa}}{2} \\ &= 73.35 \text{ MPa}\end{aligned}$
<p><i>Step 2.</i> Calculate the maximum shear stress (τ_{max}) from Eq. (5.12) as</p> $\begin{aligned}\tau_{\text{max}} &= \sqrt{\left(\frac{\sigma_{xx} - \sigma_{yy}}{2}\right)^2 + \tau_{xy}^2} \\ &= \sqrt{\left(\frac{15.3 - 0}{2}\right)^2 + (-3.8)^2} \text{ kpsi} \\ &= \sqrt{(7.65)^2 + (-3.8)^2} \text{ kpsi} \\ &= \sqrt{(58.52) + (14.44)} \text{ kpsi} \\ &= \sqrt{(72.96)} \text{ kpsi} = 8.54 \text{ kpsi}\end{aligned}$	<p><i>Step 2.</i> Calculate the maximum shear stress (τ_{max}) from Eq. (5.12) as</p> $\begin{aligned}\tau_{\text{max}} &= \sqrt{\left(\frac{\sigma_{xx} - \sigma_{yy}}{2}\right)^2 + \tau_{xy}^2} \\ &= \sqrt{\left(\frac{146.7 - 0}{2}\right)^2 + (-36.7)^2} \text{ MPa} \\ &= \sqrt{(73.35)^2 + (-36.7)^2} \text{ MPa} \\ &= \sqrt{(5,380.2) + (1,346.9)} \text{ MPa} \\ &= \sqrt{(6,727.1)} \text{ MPa} = 82.02 \text{ MPa}\end{aligned}$
<p><i>Step 3.</i> Using the average normal stress (σ_{avg}) found in step 1 and the maximum shear stress (τ_{max}) found in step 2, calculate the maximum principal stress (σ_1) from Eq. (5.15) as</p> $\begin{aligned}\sigma_1 &= \sigma_{\text{avg}} + \tau_{\text{max}} = (7.65 + 8.54) \text{ kpsi} \\ &= 16.19 \text{ kpsi}\end{aligned}$	<p><i>Step 3.</i> Using the average normal stress (σ_{avg}) found in step 1 and the maximum shear stress (τ_{max}) found in step 2, calculate the maximum principal stress (σ_1) from Eq. (5.15) as</p> $\begin{aligned}\sigma_1 &= \sigma_{\text{avg}} + \tau_{\text{max}} = (73.35 + 82.02) \text{ MPa} \\ &= 155.37 \text{ MPa}\end{aligned}$

U.S. Customary	SI/Metric
and use Eq. (5.16) to calculate the minimum principal stress (σ_2) as	and use Eq. (5.16) to calculate the minimum principal stress (σ_2) as
$\sigma_2 = \sigma_{\text{avg}} - \tau_{\text{max}} = (7.65 - 8.54) \text{ kpsi}$ $= -0.89 \text{ kpsi}$	$\sigma_2 = \sigma_{\text{avg}} - \tau_{\text{max}} = (73.35 - 82.02) \text{ MPa}$ $= -8.67 \text{ MPa}$
<i>Step 4.</i> Before going further, check that the values for the principal stresses (σ_1) and (σ_2) satisfy Eq. (5.17).	<i>Step 4.</i> Before going further, check that the values for the principal stresses (σ_1) and (σ_2) satisfy Eq. (5.17).
$\sigma_1 + \sigma_2 = \sigma_{xx} + \sigma_{yy}$ $(16.19 - 0.89) \text{ kpsi} = (15.3 + 0) \text{ kpsi}$ $15.3 \text{ kpsi} \equiv 15.3 \text{ kpsi}$	$\sigma_1 + \sigma_2 = \sigma_{xx} + \sigma_{yy}$ $(155.37 - 8.67) \text{ MPa} = (146.7 + 0) \text{ MPa}$ $146.7 \text{ MPa} \equiv 146.7 \text{ MPa}$
and they do.	and they do.
<i>Step 5.</i> Using Eq. (5.9), calculate the rotation angle (ϕ_p) for maximum and minimum principal stresses as	<i>Step 5.</i> Using Eq. (5.9), calculate the rotation angle (ϕ_p) for maximum and minimum principal stresses as
$\tan 2\phi_p = \frac{2\tau_{xy}}{\sigma_{xx} - \sigma_{yy}} = \frac{2(-3.8 \text{ kpsi})}{(15.3 - 0) \text{ kpsi}}$ $\tan 2\phi_p = \frac{-7.6 \text{ kpsi}}{15.3 \text{ kpsi}} = -0.497$ $2\phi_p = -26.4^\circ$ $\phi_p = -13.2^\circ$	$\tan 2\phi_p = \frac{2\tau_{xy}}{\sigma_{xx} - \sigma_{yy}} = \frac{2(-36.7 \text{ MPa})}{(146.7 - 0) \text{ MPa}}$ $\tan 2\phi_p = \frac{-73.4 \text{ MPa}}{146.7 \text{ MPa}} = -0.500$ $2\phi_p = -26.6^\circ$ $\phi_p = -13.3^\circ$
<i>Step 6.</i> Without the benefit of the graphical picture of Mohr's circle, the only way to tell which principal stress this value of the rotation angle (ϕ_p) is associated with, is to substitute this angle in Eq. (5.1) and see which stress is determined. Substituting gives	<i>Step 6.</i> Without the benefit of the graphical picture of Mohr's circle, the only way to tell which principal stress this value of the rotation angle (ϕ_p) is associated with is to substitute this angle in Eq. (5.1) and see which stress is determined. Substituting gives
$\sigma_{x'x'} = \frac{\sigma_{xx} + \sigma_{yy}}{2} + \frac{\sigma_{xx} - \sigma_{yy}}{2} \cos 2\theta$ $+ \tau_{xy} \sin 2\theta$ $= \frac{(15.3 + 0) \text{ kpsi}}{2}$ $+ \frac{(15.3 - 0) \text{ kpsi}}{2} \cos 2(-13.2^\circ)$ $+ (-3.8 \text{ kpsi}) \sin 2(-13.2^\circ)$ $= (7.65 \text{ kpsi})$ $+ (7.65 \text{ kpsi}) \cos(-26.4^\circ)$ $+ (-3.8 \text{ kpsi}) \sin(-26.4^\circ)$ $= (7.65 \text{ kpsi})$ $+ (7.65 \text{ kpsi})(0.896)$ $+ (-3.8 \text{ kpsi})(-0.445)$	$\sigma_{x'x'} = \frac{\sigma_{xx} + \sigma_{yy}}{2} + \frac{\sigma_{xx} - \sigma_{yy}}{2} \cos 2\theta$ $+ \tau_{xy} \sin 2\theta$ $= \frac{(146.7 + 0) \text{ MPa}}{2}$ $+ \frac{(146.7 - 0) \text{ MPa}}{2} \cos 2(-13.3^\circ)$ $+ (-36.7 \text{ MPa}) \sin 2(-13.3^\circ)$ $= (73.35 \text{ MPa})$ $+ (73.35 \text{ MPa}) \cos(-26.6^\circ)$ $+ (-36.7 \text{ MPa}) \sin(-26.6^\circ)$ $= (73.35 \text{ MPa})$ $+ (73.35 \text{ MPa})(0.894)$ $+ (-36.7 \text{ MPa})(-0.448)$

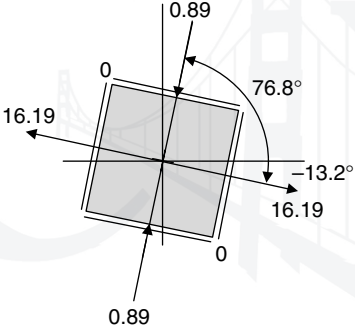
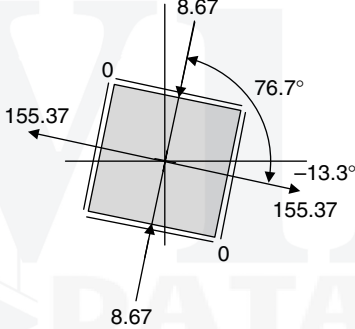
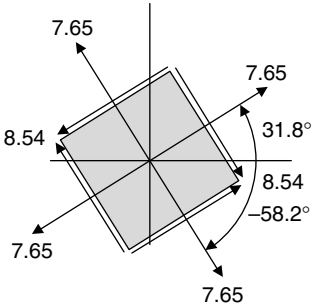
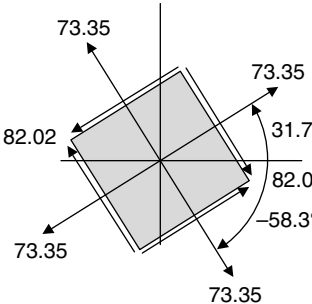
U.S. Customary	SI/Metric
<p> $= (7.65 + 6.85 + 1.69)$ kpsi $= 16.19$ kpsi $= \sigma_1$ </p> <p>So the rotation angle found in step 5 is for the maximum principal stress (σ_1).</p> <p>Step 7. Using Eq. (5.11), the rotation angle (ϕ_s) for the maximum shear stress becomes</p> $\phi_s = \phi_p \pm 45^\circ = -13.2^\circ \pm 45^\circ$ $= 31.8^\circ \text{ or } -58.2^\circ$ <p>where for reasons that will be presented in the discussion on Mohr's circle, the negative value (-58.2°) will be chosen.</p> <p>Step 8. Display the principal stresses (σ_1) and (σ_2) found in step 3 at the rotation angle (ϕ_p) found in step 5, and verified in step 6, in a rotated element.</p> 	<p> $= (73.35 + 65.58 + 16.44)$ MPa $= 155.37$ MPa </p> <p>So the rotation angle found in step 5 is for the maximum principal stress (σ_1).</p> <p>Step 7. Using Eq. (5.11), the rotation angle (ϕ_s) for the maximum shear stress becomes</p> $\phi_s = \phi_p \pm 45^\circ = -13.3^\circ \pm 45^\circ$ $= 31.7^\circ \text{ or } -58.3^\circ$ <p>where for reasons that will be presented in the discussion on Mohr's circle, the negative value (-58.3°) will be chosen.</p> <p>Step 8. Display the principal stresses (σ_1) and (σ_2) found in step 3 at the rotation angle (ϕ_p) found in step 5, and verified in step 6, in a rotated element.</p> 
<p>Step 9. Display the maximum and minimum shear stresses found in step 2, the average stress found in step 1 at the rotation angle (ϕ_s) chosen in step 7 in a rotated element.</p> 	<p>Step 9. Display the maximum and minimum shear stresses found in step 2, the average stress found in step 1 at the rotation angle (ϕ_s) chosen in step 7 in a rotated element.</p> 

As already mentioned, it is very difficult in actual practice to have a combination of loadings that produce nonzero values of all three stresses (σ_{xx}), (σ_{yy}), and (τ_{xy}) on a plane stress element. However, to provide another example using the equations presented in this section, consider the following rather contrived set of unrotated stresses.

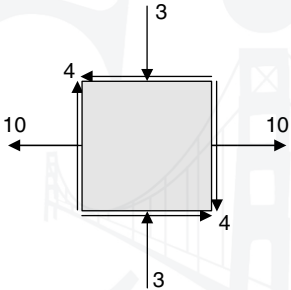
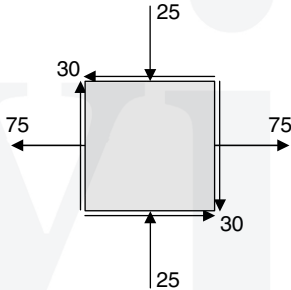
U.S. Customary	SI/Metric
<p>Example 5. For the normal and shear stresses given below, find the principal stresses (σ_1) and (σ_2), maximum and minimum shear stresses (τ_{\max}) and (τ_{\min}), and the special angles (ϕ_p) and (ϕ_s), and display these values in appropriate rotated plane stress elements, where</p> $\sigma_{xx} = 10 \text{ kpsi}$ $\sigma_{yy} = -3 \text{ kpsi}$ $\tau_{xy} = -4 \text{ kpsi}$ <p>displayed in the following element:</p> 	<p>Example 5. For the normal and shear stresses given below, find the principal stresses (σ_1) and (σ_2), maximum and minimum shear stresses (τ_{\max}) and (τ_{\min}), and the special angles (ϕ_p) and (ϕ_s), and display these values on appropriate rotated plane stress elements, where</p> $\sigma_{xx} = 75 \text{ MPa}$ $\sigma_{yy} = -25 \text{ MPa}$ $\tau_{xy} = -30 \text{ MPa}$ <p>displayed in the following element:</p> 
<p>solution</p> <p><i>Step 1.</i> Calculate the average normal stress (σ_{avg}) from Eq. (5.14) as</p> $\sigma_{\text{avg}} = \frac{\sigma_{xx} + \sigma_{yy}}{2} = \frac{[10 + (-3)] \text{ kpsi}}{2}$ $= 3.5 \text{ kpsi}$ <p><i>Step 2.</i> Calculate the maximum shear stress (τ_{\max}) from Eq. (5.12) as</p> $\tau_{\max} = \sqrt{\left(\frac{\sigma_{xx} - \sigma_{yy}}{2}\right)^2 + \tau_{xy}^2}$ $= \sqrt{\left(\frac{10 - (-3)}{2}\right)^2 + (-4)^2} \text{ kpsi}$ $= \sqrt{(6.5)^2 + (-4)^2} \text{ kpsi}$ $= \sqrt{(42.25) + (16)} \text{ kpsi}$ $= \sqrt{(58.25)} \text{ kpsi}$ $= 7.6 \text{ kpsi} \simeq 7.5 \text{ kpsi}$	<p>solution</p> <p><i>Step 1.</i> Calculate the average normal stress (σ_{avg}) from Eq. (5.14) as</p> $\sigma_{\text{avg}} = \frac{\sigma_{xx} + \sigma_{yy}}{2} = \frac{[75 + (-25)] \text{ MPa}}{2}$ $= 25 \text{ MPa}$ <p><i>Step 2.</i> Calculate the maximum shear stress (τ_{\max}) from Eq. (5.12) as</p> $\tau_{\max} = \sqrt{\left(\frac{\sigma_{xx} - \sigma_{yy}}{2}\right)^2 + \tau_{xy}^2}$ $= \sqrt{\left(\frac{75 - (-25)}{2}\right)^2 + (-30)^2} \text{ MPa}$ $= \sqrt{(50)^2 + (-30)^2} \text{ MPa}$ $= \sqrt{(2,500) + (900)} \text{ MPa}$ $= \sqrt{(3,400)} \text{ MPa}$ $= 58.3 \text{ MPa} \simeq 58 \text{ MPa}$

U.S. Customary	SI/Metric
and the minimum shear stress (τ_{\min}) is	and the minimum shear stress (τ_{\min}) is
$\tau_{\min} = -\tau_{\max} = -7.5 \text{ kpsi}$	$\tau_{\min} = -\tau_{\max} = -58 \text{ kpsi}$
<i>Step 3.</i> Using the average normal stress (σ_{avg}) found in step 1 and the maximum shear stress (τ_{max}) found in step 2, calculate the maximum principal stress (σ_1) from Eq. (5.15) as	<i>Step 3.</i> Using the average normal stress (σ_{avg}) found in step 1 and the maximum shear stress (τ_{max}) found in step 2, calculate the maximum principal stress (σ_1) from Eq. (5.15) as
$\begin{aligned}\sigma_1 &= \sigma_{\text{avg}} + \tau_{\text{max}} = (3.5 + 7.5) \text{ kpsi} \\ &= 11 \text{ kpsi}\end{aligned}$	$\begin{aligned}\sigma_1 &= \sigma_{\text{avg}} + \tau_{\text{max}} = (25 + 58) \text{ MPa} \\ &= 83 \text{ MPa}\end{aligned}$
and use Eq. (5.16) to calculate the minimum principal stress (σ_2) as	and use Eq. (5.16) to calculate the minimum principal stress (σ_2) as
$\begin{aligned}\sigma_2 &= \sigma_{\text{avg}} - \tau_{\text{max}} = (3.5 - 7.5) \text{ kpsi} \\ &= -4 \text{ kpsi}\end{aligned}$	$\begin{aligned}\sigma_2 &= \sigma_{\text{avg}} - \tau_{\text{max}} = (25 - 58) \text{ MPa} \\ &= -33 \text{ MPa}\end{aligned}$
<i>Step 4.</i> Before going further, check that the values for the principal stresses (σ_1) and (σ_2) satisfy Eq. (5.17)	<i>Step 4.</i> Before going further, check that the values for the principal stresses (σ_1) and (σ_2) satisfy Eq. (5.17)
$\begin{aligned}\sigma_1 + \sigma_2 &= \sigma_{xx} + \sigma_{yy} \\ [11 + (-4)] \text{ kpsi} &= [10 + (-3)] \text{ kpsi} \\ 7 \text{ kpsi} &\equiv 7 \text{ kpsi}\end{aligned}$	$\begin{aligned}\sigma_1 + \sigma_2 &= \sigma_{xx} + \sigma_{yy} \\ [83 + (-33)] \text{ MPa} &= [75 + (-25)] \text{ MPa} \\ 50 \text{ MPa} &\equiv 50 \text{ MPa}\end{aligned}$
and they do.	and they do.
<i>Step 5.</i> Using Eq. (5.9), calculate the rotation angle (ϕ_p) for maximum and minimum principal stresses as	<i>Step 5.</i> Using Eq. (5.9), calculate the rotation angle (ϕ_p) for maximum and minimum principal stresses as
$\begin{aligned}\tan 2\phi_p &= \frac{2\tau_{xy}}{\sigma_{xx} - \sigma_{yy}} \\ &= \frac{2(-4 \text{ kpsi})}{[10 - (-3)] \text{ kpsi}} \\ \tan 2\phi_p &= \frac{-8 \text{ kpsi}}{13 \text{ kpsi}} = -0.615 \\ 2\phi_p &= -31.6^\circ \\ \phi_p &= -15.8^\circ\end{aligned}$	$\begin{aligned}\tan 2\phi_p &= \frac{2\tau_{xy}}{\sigma_{xx} - \sigma_{yy}} \\ &= \frac{2(-30 \text{ MPa})}{[75 - (-25)] \text{ MPa}} \\ \tan 2\phi_p &= \frac{-60 \text{ MPa}}{100 \text{ MPa}} = -0.600 \\ 2\phi_p &= -31.0^\circ \\ \phi_p &= -15.5^\circ\end{aligned}$
<i>Step 6.</i> Without the benefit of the graphical picture of Mohr's circle, the only way to tell which principal stress this value of the rotation angle (ϕ_p) is associated with is to substitute this angle in Eq. (5.1) and see which stress is	<i>Step 6.</i> Without the benefit of the graphical picture of Mohr's circle, the only way to tell which principal stress this value of the rotation angle (ϕ_p) is associated with is to substitute this angle in Eq. (5.1) and see which stress is

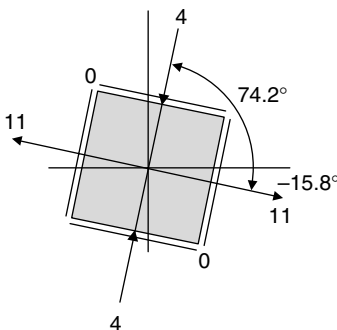
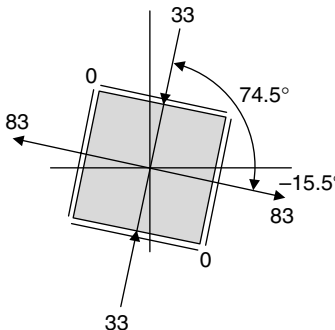
U.S. Customary	SI/Metric
<p>determined. Substituting gives</p> $\begin{aligned} \sigma_{x'x'} &= \frac{\sigma_{xx} + \sigma_{yy}}{2} + \frac{\sigma_{xx} - \sigma_{yy}}{2} \cos 2\theta \\ &\quad + \tau_{xy} \sin 2\theta \\ &= \frac{[10 + (-3)] \text{ kpsi}}{2} \\ &\quad + \frac{[10 - (-3)] \text{ kpsi}}{2} \cos 2(-15.8^\circ) \\ &\quad + (-4 \text{ kpsi}) \sin 2(-15.8^\circ) \\ &= (3.5 \text{ kpsi}) + (6.5 \text{ kpsi}) \cos(-31.6^\circ) \\ &\quad + (-4 \text{ kpsi}) \sin(-31.6^\circ) \\ &= (3.5 \text{ kpsi}) + (6.5 \text{ kpsi})(0.852) \\ &\quad + (-4 \text{ kpsi})(-0.524) \\ &= (3.5 + 5.5 + 2) \text{ kpsi} \\ &= 11 \text{ kpsi} = \sigma_1 \end{aligned}$	<p>determined. Substituting gives</p> $\begin{aligned} \sigma_{x'x'} &= \frac{\sigma_{xx} + \sigma_{yy}}{2} + \frac{\sigma_{xx} - \sigma_{yy}}{2} \cos 2\theta \\ &\quad + \tau_{xy} \sin 2\theta \\ &= \frac{[75 + (-25)] \text{ MPa}}{2} \\ &\quad + \frac{[75 - (-25)] \text{ MPa}}{2} \cos 2(-15.5^\circ) \\ &\quad + (-30 \text{ MPa}) \sin 2(-15.5^\circ) \\ &= (25 \text{ MPa}) + (50 \text{ MPa}) \cos(-31.0^\circ) \\ &\quad + (-30 \text{ MPa}) \sin(-31.0^\circ) \\ &= (25 \text{ MPa}) + (50 \text{ MPa})(0.857) \\ &\quad + (-30 \text{ MPa})(-0.515) \\ &= (25 + 43 + 15) \text{ MPa} \\ &= 83 \text{ MPa} \end{aligned}$
<p>So the rotation angle found in step 5 is for the maximum principal stress (σ_1).</p>	<p>So the rotation angle found in step 5 is for the maximum principal stress (σ_1).</p>
<p><i>Step 7.</i> Using Eq. (5.11), the rotation angle (ϕ_s) for the maximum shear stress becomes</p> $\begin{aligned} \phi_s &= \phi_p \pm 45^\circ = -15.8^\circ \pm 45^\circ \\ &= 29.2^\circ \quad \text{or} \quad -60.8^\circ \end{aligned}$	<p><i>Step 7.</i> Using Eq. (5.11), the rotation angle (ϕ_s) for the maximum shear stress becomes</p> $\begin{aligned} \phi_s &= \phi_p \pm 45^\circ = -15.5^\circ \pm 45^\circ \\ &= 29.5^\circ \quad \text{or} \quad -60.5^\circ \end{aligned}$
<p>where for reasons that will be presented in the discussion on Mohr's circle, the negative value (-60.8°) will be chosen.</p>	<p>where for reasons that will be presented in the discussion on Mohr's circle, the negative value (-60.5°) will be chosen.</p>
<p><i>Step 8.</i> Display the principal stresses (σ_1) and (σ_2) found in step 3 at the rotation angle (ϕ_p) found in step 5, and verified in step 6, in a rotated element.</p>	<p><i>Step 8.</i> Display the principal stresses (σ_1) and (σ_2) found in step 3 at the rotation angle (ϕ_p) found in step 5, and verified in step 6, in a rotated element.</p>
	

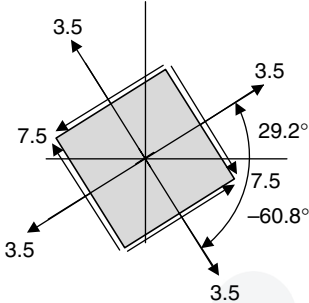
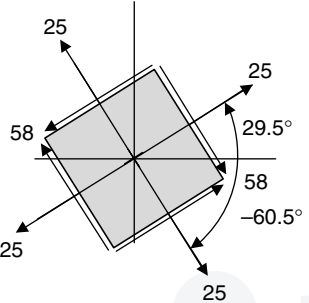
U.S. Customary	SI/Metric
<p><i>Step 9.</i> Display the maximum and minimum shear stresses found in step 2, the average stress found in step 1 at the rotation angle (ϕ_s) chosen in step 7 in a rotated element.</p> 	<p><i>Step 9.</i> Display the maximum and minimum shear stresses found in step 2, the average stress found in step 1 at the rotation angle (ϕ_s) chosen in step 7 in a rotated element.</p> 

While the previous examples show the extent of the calculations needed to transform unrotated stresses to rotated stresses, particularly to find the principal stresses and maximum and minimum shear stresses, there exists a graphical approach that can visually provide the necessary transformations called Mohr's circle. Unfortunately, Mohr's circle is presented in school and in many references in such a complicated manner, typically using only one very detailed diagram, that too many practicing engineers avoid even the thought of using Mohr's circle in an analysis. What follows is a very deliberate step-by-step presentation, with numerous examples, that is hoped will change this negative view of using Mohr's circle to determine extremely important design information.

5.3 MOHR'S CIRCLE

As presented in Sec. 5.1, if the unrotated plane stress element on the left in Fig. 5.5, shown below, is rotated an angle (θ) to give the element on the right in Fig. 5.5, then a set of three equations can be developed relating the unrotated stresses (σ_{xx}), (σ_{yy}), and (τ_{xy}), which are usually known, to the rotated stresses ($\sigma_{x'x'}$), ($\sigma_{y'y'}$), and ($\tau_{x'y'}$).

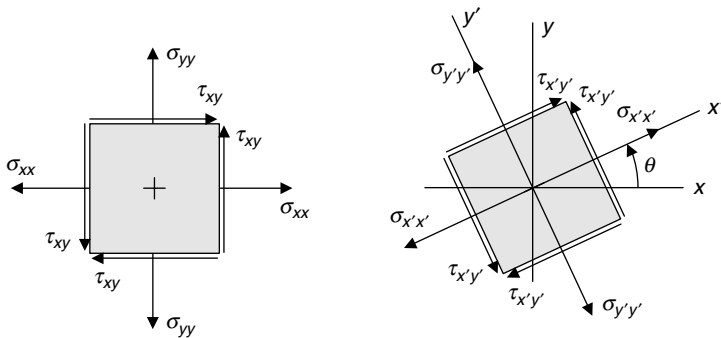

FIGURE 5.5 Rotated plane stress element.

These three transformation equations between the unrotated stresses and the rotated stresses were presented in Sec. 5.1 as follows:

$$\sigma_{x'x'} = \frac{\sigma_{xx} + \sigma_{yy}}{2} + \frac{\sigma_{xx} - \sigma_{yy}}{2} \cos 2\theta + \tau_{xy} \sin 2\theta \quad (5.1)$$

$$\sigma_{y'y'} = \frac{\sigma_{xx} + \sigma_{yy}}{2} - \frac{\sigma_{xx} - \sigma_{yy}}{2} \cos 2\theta - \tau_{xy} \sin 2\theta \quad (5.2)$$

$$\tau_{x'y'} = -\frac{\sigma_{xx} - \sigma_{yy}}{2} \sin 2\theta + \tau_{xy} \cos 2\theta \quad (5.3)$$

Furthermore, it was shown that there is a special angle of rotation (ϕ_p), determined by the following equation,

$$\tan 2\phi_p = \frac{2\tau_{xy}}{\sigma_{xx} - \sigma_{yy}} \quad (5.9)$$

that if this special angle of rotation is substituted in Eqs. (5.1) to (5.3), then a maximum principal stress (σ_1) and a minimum principal stress (σ_2) would result, given by the following equations,

$$\sigma_1 = \sigma_{\text{avg}} + \tau_{\text{max}} \quad (5.15)$$

$$\sigma_2 = \sigma_{\text{avg}} - \tau_{\text{max}} \quad (5.16)$$

and where the shear stress on the element showing (σ_1) and (σ_2) would be zero.

The first term on the right-hand side of Eqs. (5.15) and (5.16) is the average stress (σ_{avg}) determined by the following equation,

$$\sigma_{\text{avg}} = \frac{\sigma_{xx} + \sigma_{yy}}{2} \quad (5.14)$$

and the second terms (τ_{max}) and (τ_{min}) are determined from the following equations:

$$\tau_{\text{max}} = \sqrt{\left(\frac{\sigma_{xx} - \sigma_{yy}}{2}\right)^2 + \tau_{xy}^2} \quad (5.12)$$

$$\tau_{\text{min}} = -\tau_{\text{max}} \quad (5.13)$$

To provide a check on these calculations, the following relationship must always be satisfied between the principal stresses and the unrotated stresses:

$$\sigma_1 + \sigma_2 = \sigma_{xx} + \sigma_{yy} \quad (5.17)$$

It was also shown in Sec. 5.1 that the maximum and minimum shear stresses occur in an element rotated 45 degrees from the angle (ϕ_p), denoted (ϕ_s), and determined from the following equation:

$$\tan 2\phi_s = -\frac{\sigma_{xx} - \sigma_{yy}}{2\tau_{xy}} \quad (5.10)$$

However, it was also shown that if the angle (ϕ_p) for the principal stresses is already known, then the angle (ϕ_s) can be found from the relationship:

$$\phi_s = \phi_p \pm 45^\circ \quad (5.11)$$

It was stated in Sec. 5.1 without proof that if the angle (ϕ_p) for the maximum principal stress (σ_1) were known, then the angle (ϕ_s) for the maximum shear stress (τ_{max}) could be found from the following equation:

$$\phi_s = \phi_p - 45^\circ \quad (5.18)$$

Mohr's Circle. The proof of Eq. (5.18), and other relationships and design information, can be discovered using Mohr's circle. The origin and development of Mohr's circle is very interesting and is contained in any number of excellent references. For the purposes of this book focusing on *calculations*, the origin and development will be omitted.

One important usefulness of Mohr's circle is to display the maximum and minimum principal stresses, the maximum and minimum shear stresses, and the average stress once they are determined. Such a Mohr's circle is shown in Fig. 5.6.

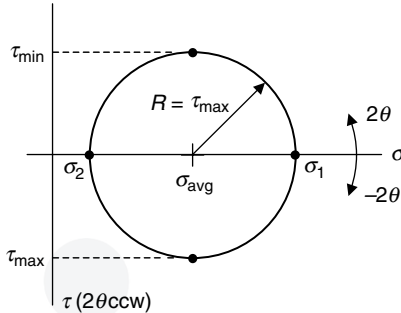

FIGURE 5.6 Mohr's circle.

Notice that the average stress (σ_{avg}) locates the center of Mohr's circle and the maximum shear stress (τ_{max}) is the radius (R). The horizontal axis is the normal stress (σ) and the vertical axis is the shear stress (τ), where positive (τ) is *downward* so that the rotation angle (2θ) on Mohr's circle is in the same *counterclockwise* (ccw) direction as the rotation angle (θ) on the plane stress element.

The proof of Eq. (5.18) is now clear that to go from the point on the circle of maximum principal stress (σ_1) to the point on the circle for maximum shear stress (τ_{max}) the angle of rotation (2θ) is clockwise, or a minus 90° , so the angle (θ) would be half this value, or a minus 45° clockwise.

Also notice that Mohr's circle verifies Eqs. (5.15) and (5.16), where the maximum principal stress (σ_1) is the average stress (σ_{avg}) *plus* the maximum shear stress (τ_{max}), and the minimum principal stress (σ_2) is the average stress (σ_{avg}) *minus* the maximum shear stress (τ_{max}). As the maximum and minimum shear stresses (τ_{max}) and (τ_{min}) are opposites, Fig. 5.6 shows them at opposite points on the circle.

The circle does not always end up on the right side of the vertical (τ) axis. It can straddle the axis as in Fig. 5.7, or be completely on the left side of the vertical (τ) axis like that shown in Fig. 5.8.

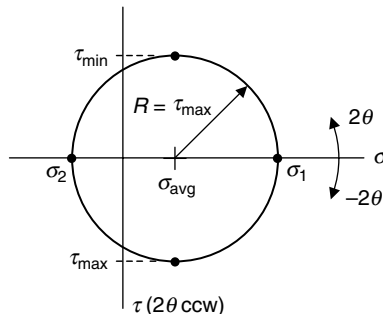

FIGURE 5.7 Mohr's circle.

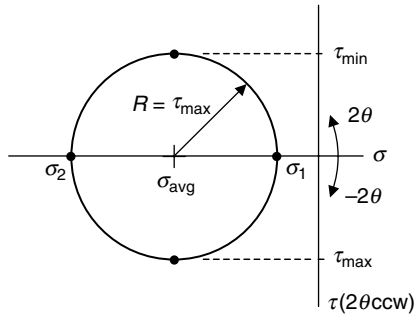

FIGURE 5.8 Mohr's circle.

Graphical Process. If this was all there was to Mohr's circle, merely a way to display values already found analytically from various equations, then it would not have been worth mentioning. However, Mohr's circle can be used to *graphically* determine the maximum and minimum principal stresses (σ_1) and (σ_2), the maximum and minimum shear stresses (τ_{\max}) and (τ_{\min}), the rotation angles (ϕ_p) and (ϕ_s), all from the given unrotated stresses (σ_{xx}), (σ_{yy}), and (τ_{xy}).

In most references, the steps of this process are discussed using a single figure that is one of the most complex diagrams in engineering. To hopefully make this process as simple as possible, a series of Mohr's circle figures for each step will be used to slowly lead up to the final diagram. Remember that positive shear stress (τ) is plotted downward. Furthermore, for the following process development assume all the unrotated stresses are positive and that (σ_{xx}) is greater than (σ_{yy}).

The first step in the process is to plot two points: one point having the coordinates (σ_{xx}, τ_{xy}) and the other point having the coordinates ($\sigma_{yy}, -\tau_{xy}$), as shown in Fig. 5.9.

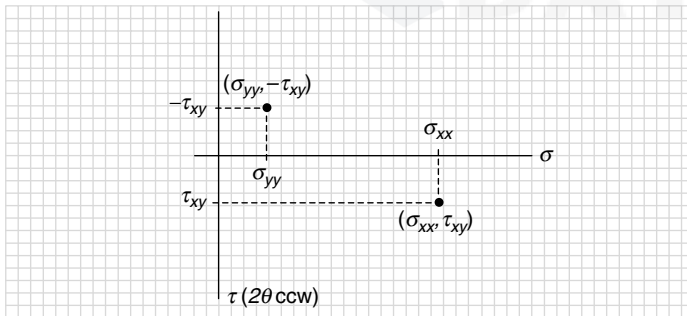

FIGURE 5.9 Plot points (σ_{xx}, τ_{xy}) and ($\sigma_{yy}, -\tau_{xy}$).

A line connecting these two points crosses the (σ) axis at the average stress (σ_{avg}) as shown in Fig. 5.10.

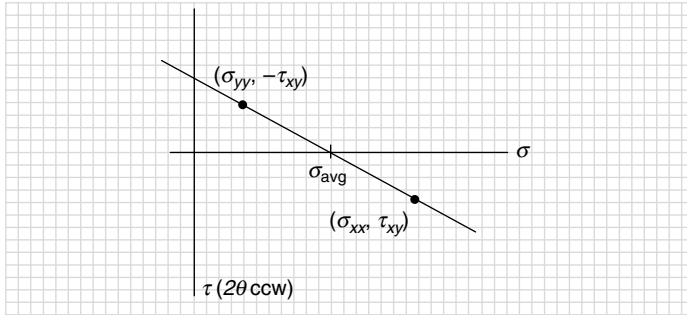

FIGURE 5.10 Connect points to find average stress (σ_{avg}).

Use distance from the average stress to either point as a radius and draw a circle as shown in Fig. 5.11.

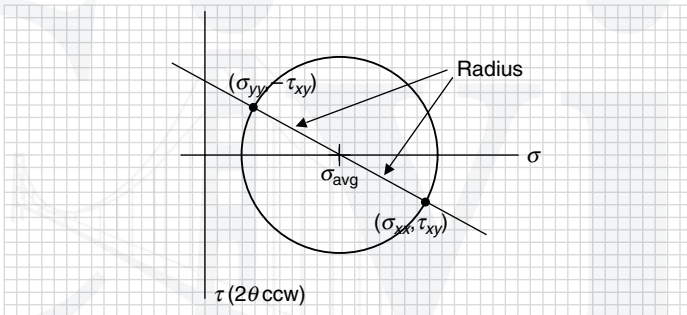

FIGURE 5.11 Draw circle.

Where this circle crosses the (σ) axis on the right locates the maximum principal stress (σ_1), and where it crosses on the left is the minimum principal stress (σ_2). The radius of the circle (R) is the maximum shear stress (τ_{max}) as shown in Fig. 5.12.

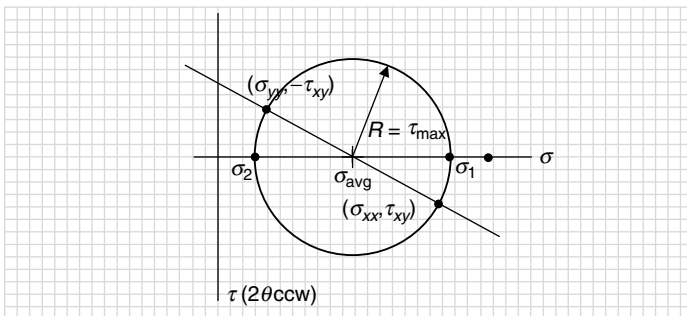

FIGURE 5.12 Principal stresses and radius of circle.

Figure 5.13 shows that at 90° to the principal stresses are the maximum and minimum shear stresses.

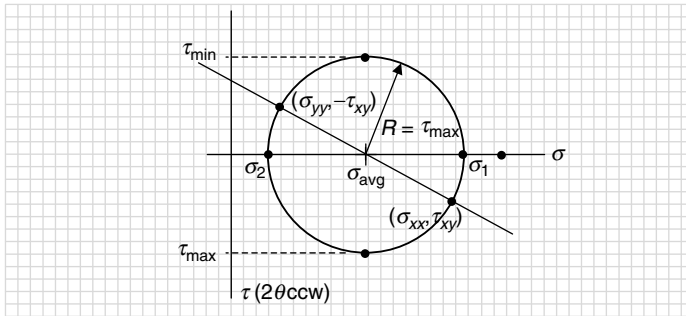

FIGURE 5.13 Maximum and minimum shear stresses.

This completes the determination, graphically, of the principal stresses, maximum and minimum shear stresses, and the average stress. Although modern personal calculators make using the various equations rather simple, finding these stresses graphically gives a feeling and an understanding of the relationship between the unrotated stresses and the rotated stresses not possible with just a calculator.

The angle between the line connecting the points (σ_{xx}, τ_{xy}) and $(\sigma_{xx}, -\tau_{xy})$ and the (σ) axis is the principal stress angle $(2\phi_p)$. Notice that to move from the point (σ_{xx}, τ_{xy}) to the (σ) axis, the rotation angle $(2\phi_p)$ is counterclockwise (5.14).

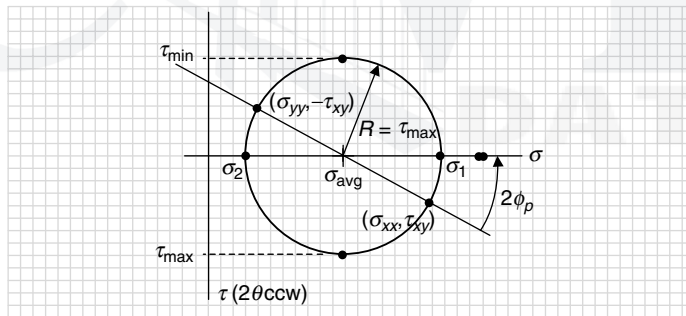

FIGURE 5.14 Principal stresses angle (ϕ_p) .

The angle between the line connecting the points (σ_{xx}, τ_{xy}) and $(\sigma_{xx}, -\tau_{xy})$ and the positive (τ) axis is the maximum stress angle $(2\phi_s)$. Notice that to move from the point (σ_{xx}, τ_{xy}) to the (τ) axis, the rotation angle $(2\phi_s)$ is clockwise.

Again, the proof of Eq. (5.18) is clear from Fig. 5.15 with the relationship:

$$\begin{aligned} 2\phi_s &= 2\phi_p - 90^\circ \\ \phi_s &= \phi_p - 45^\circ \end{aligned} \tag{5.18}$$

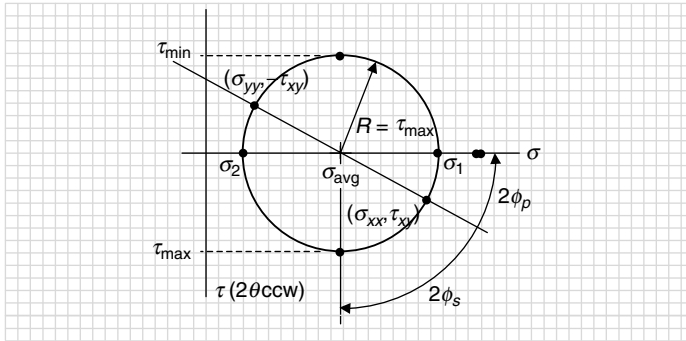

FIGURE 5.15 Maximum shear stress angle (ϕ_s).

Due to the graphical nature of the process, the following example will be presented first in the U.S. Customary system of units and then in the SI/metric system.

U.S. Customary

Example 1. Using the stresses below from Example 5, determine the principal stresses, maximum and minimum shear stresses, and rotation angles by the Mohr's circle process.

$$\sigma_{xx} = 10 \text{ kpsi} \quad \sigma_{yy} = -3 \text{ kpsi} \quad \tau_{xy} = -4 \text{ kpsi}$$

The first step in the process is to plot two points; one point having the coordinates (σ_{xx}, τ_{xy}) and the other point having the coordinates $(\sigma_{yy}, -\tau_{xy})$, that is $(10, -4)$ and $(-3, 4)$ as shown in Fig. 5.16.

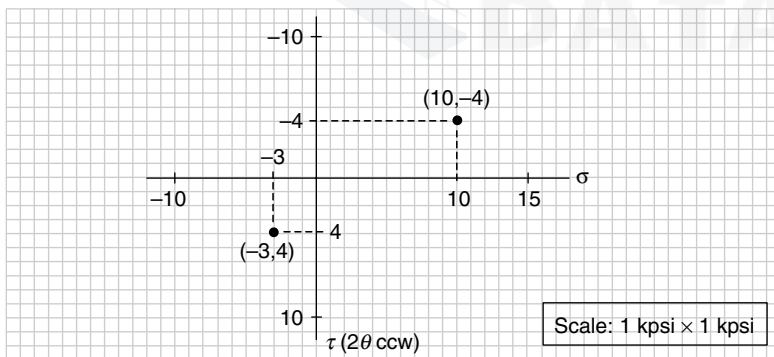

FIGURE 5.16 Plot points (σ_{xx}, τ_{xy}) and $(\sigma_{yy}, -\tau_{xy})$.

Figure 5.17 shows that a line connecting these two points crosses the (σ) axis at the average stress (3.5).

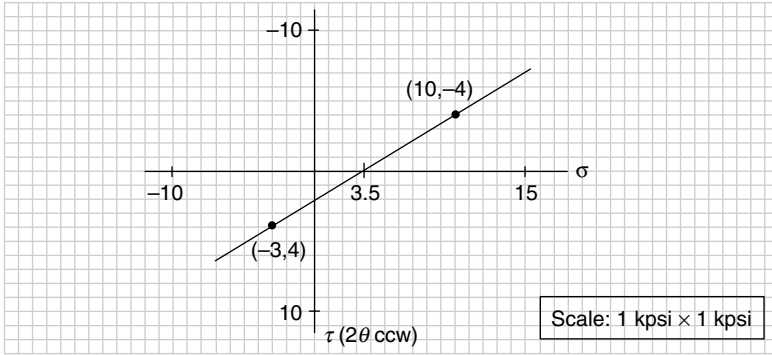

FIGURE 5.17 Connect points to find average stress (σ_{avg}).

Use distance from the average stress to either point as a radius and draw a circle (Fig. 5.18).

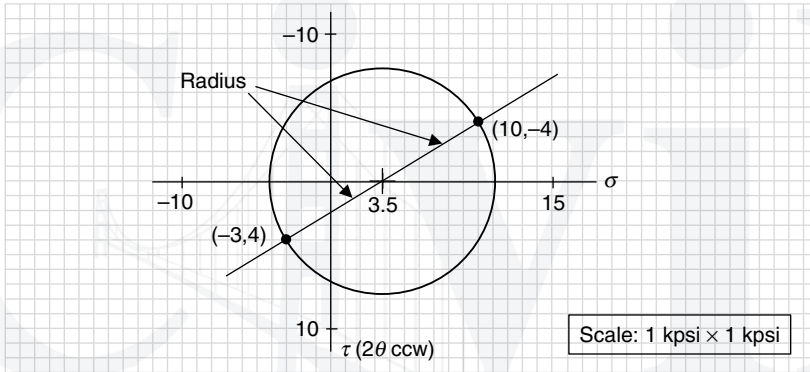

FIGURE 5.18 Draw circle.

Graphically from Fig. 5.19, the maximum principal stress is (11), and the minimum principal stress is (-4). The radius of the circle is the maximum shear stress, and scales to (7.5). These are the same values found in Example 5 in Sec. 5.2.

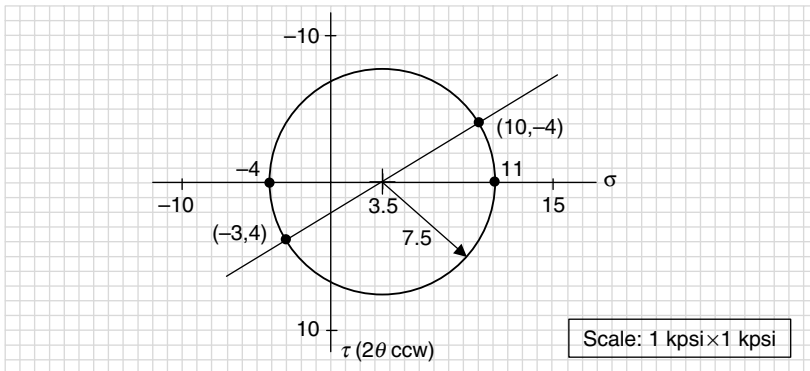

FIGURE 5.19 Principal stresses and radius of circle.

Figure 5.19 also verifies graphically Eqs. (5.15) and (5.16) for the maximum principal stress (σ_1) and a minimum principal stress (σ_2),

$$\sigma_1 = \sigma_{\text{avg}} + \tau_{\text{max}} = (3.5 + 7.5) \text{ kpsi} = 11 \text{ kpsi}$$

$$\sigma_2 = \sigma_{\text{avg}} - \tau_{\text{max}} = (3.5 - 7.5) \text{ kpsi} = -4 \text{ kpsi}$$

and since the principal stresses are on the (σ) axis, the shear stress is zero at these points.

At 90° to the principal stresses are the maximum and minimum shear stresses, (7.5) and (-7.5), with the normal stress at these points equal to the average stress (3.5) as shown in Fig. 5.20.

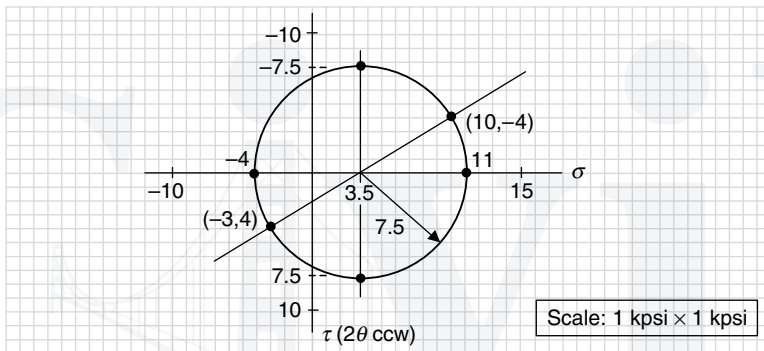

FIGURE 5.20 Maximum and minimum shear stresses.

The angle between the line connecting points (10, -4) and (-3, 4) and the (σ) axis is the principal stress angle ($2\phi_p$). From Fig. 5.21, this will be a clockwise, or negative, rotation.

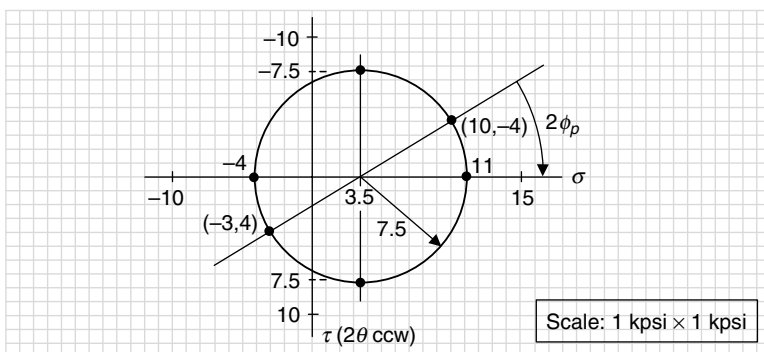
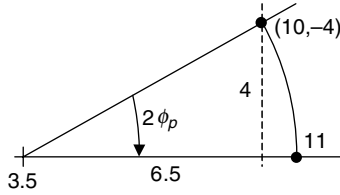

FIGURE 5.21 Principal stresses angle (ϕ_p).

Enlarging the section containing the principal stress angle ($2\phi_p$) gives:



Applying the definition of the tangent function to the right triangle containing the principal stress angle ($2\phi_p$), and using the dimensions shown, gives

$$\tan 2\phi_p = \frac{\text{opposite}}{\text{adjacent}} = \frac{4 \text{ kpsi}}{6.5 \text{ kpsi}} = 0.615$$

However, as the rotation is clockwise the principal stress angle (ϕ_p) will be negative. Changing the sign on ($\tan 2\phi_p$) and solving for the angle (ϕ_p) gives the same value as was found in Example 5 in Sec. 5.1, that is (-15.8°).

$$\tan 2\phi_p = -0.615$$

$$2\phi_p = -31.6^\circ$$

$$\phi_p = -15.8^\circ$$

Similarly, the angle between the line connecting points (10,-4) and (-3,4) and the positive (τ) axis is the maximum shear stress angle ($2\phi_s$). From Fig. 5.22, this will be a clockwise, or negative, rotation, and be 90° more than the principal stress angle ($2\phi_p$).

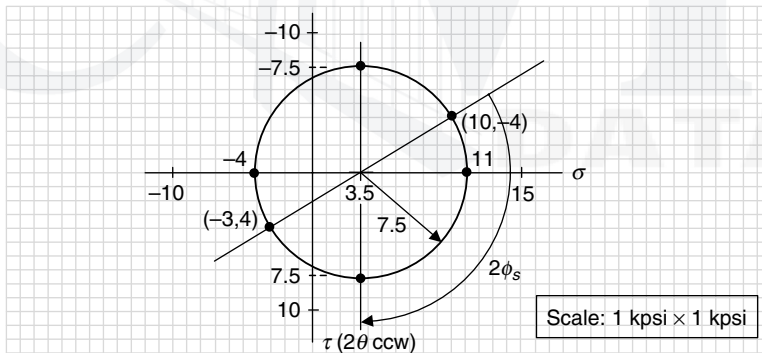

FIGURE 5.22 Maximum shear stress angle (ϕ_s).

From Fig. 5.22, and ($2\phi_p$) found above, the shear stress angle (ϕ_s) becomes

$$2\phi_s = 2\phi_p - 90^\circ = (-31.6^\circ) - 90^\circ = -121.6^\circ$$

$$\phi_s = -60.8^\circ$$

Again, this is the same value of (ϕ_s) found in Example 5 in Sec. 5.1, that is (-60.8°). So the design information found mathematically has been found graphically.

SI/Metric

Example 1. Using the stresses below from Example 5, determine the principal stresses, maximum and minimum shear stresses, and rotation angles by the Mohr's circle process.

$$\sigma_{xx} = 75 \text{ MPa} \quad \sigma_{yy} = -25 \text{ MPa} \quad \tau_{xy} = -30 \text{ MPa}$$

The first step in the process is to plot two points, one point having the coordinates (σ_{xx}, τ_{xy}) and the other having the coordinates $(\sigma_{yy}, -\tau_{xy})$, that is, $(75, -30)$ and $(-25, 30)$ as in Fig. 5.23.

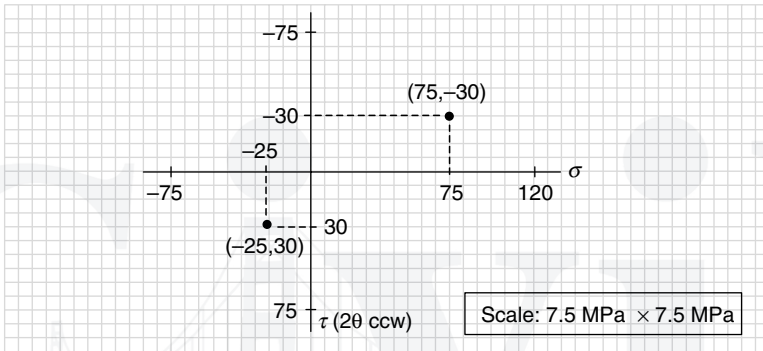

FIGURE 5.23 Plot points (σ_{xx}, τ_{xy}) and $(\sigma_{yy}, -\tau_{xy})$.

Figure 5.24 shows that a line connecting these two points crosses the (σ) axis at the average stress (26).

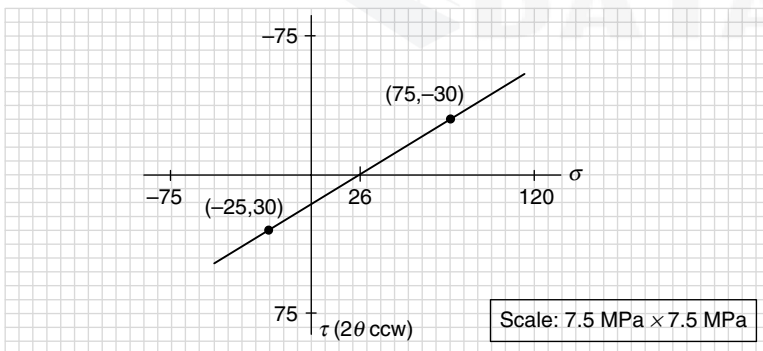

FIGURE 5.24 Connect points to find average stress (σ_{avg}) .

Use distance from the average stress to either point as a radius and draw a circle (Fig. 5.25).

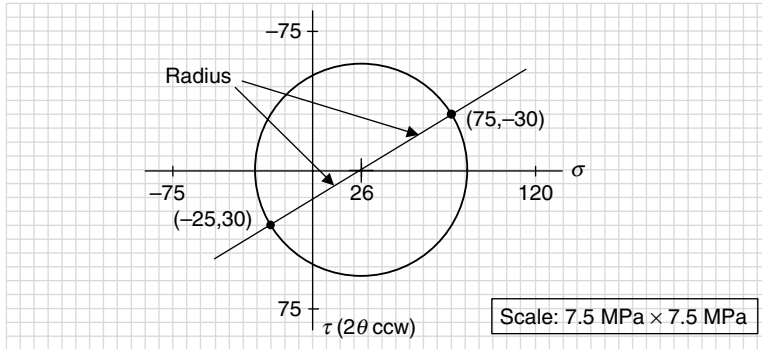

FIGURE 5.25 Draw circle.

Graphically from Fig. 5.26, the maximum principal stress is (82.5), and the minimum principal stress is (-30.5). The radius of the circle is the maximum shear stress, and scales to (56.5). These are very close to the values found in Example 5.

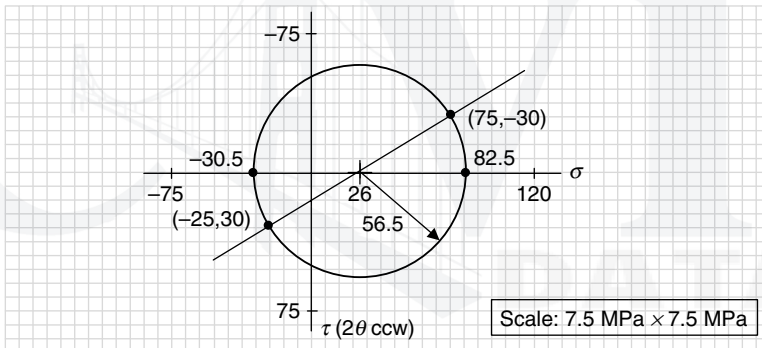

FIGURE 5.26 Principal stresses and radius of circle.

Figure 5.26 also verifies graphically Eqs. (5.15) and (5.16) for the maximum principal stress (σ_1) and a minimum principal stress (σ_2),

$$\sigma_1 = \sigma_{\text{avg}} + \tau_{\text{max}} = (26 + 56.5) \text{ MPa} = 82.5 \text{ MPa}$$

$$\sigma_2 = \sigma_{\text{avg}} - \tau_{\text{max}} = (26 - 56.5) \text{ MPa} = -30.5 \text{ MPa}$$

and as the principal stresses are on the (σ) axis, the shear stress is zero at these points.

At 90° to the principal stresses are the maximum and minimum shear stresses, (56.5) and (-56.5), with the normal stress at these points equal to the average stress (Fig. 27).

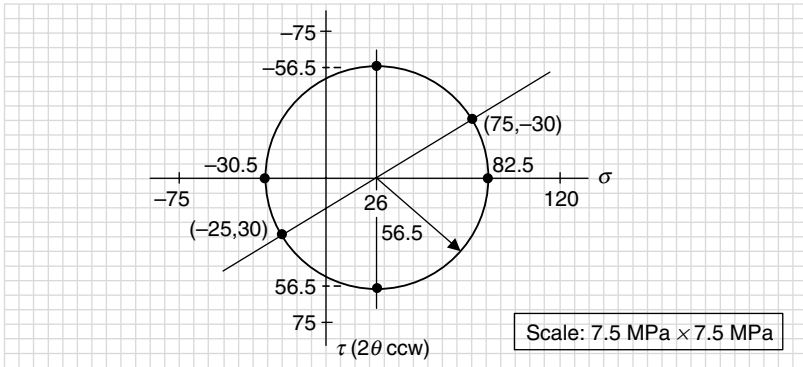

FIGURE 5.27 Maximum and minimum shear stresses.

The angle between the line connecting points (75, -30) and (-25, 30) and the (σ) axis is the principal stress angle ($2\phi_p$). From Fig. 5.28, this will be a clockwise, or negative, rotation.

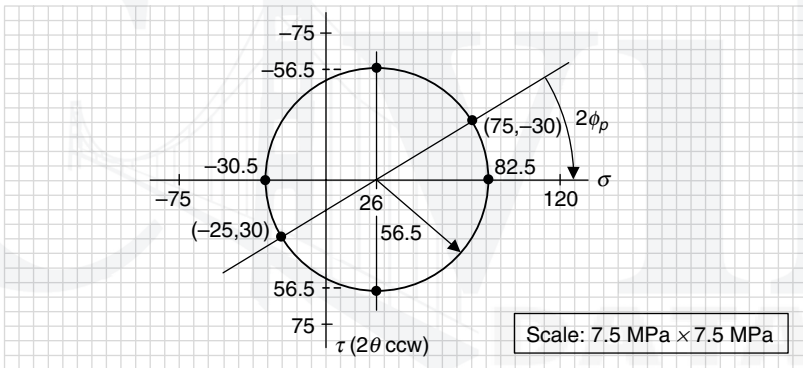
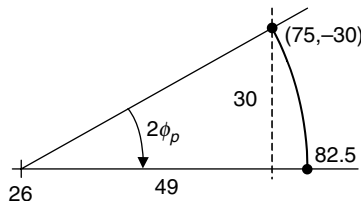

FIGURE 5.28 Principal stresses angle (ϕ_p).

Enlarging the section containing the principal stress angle ($2\phi_p$) gives:



Applying the definition of the tangent function to the right triangle containing the principal stress angle ($2\phi_p$), and using the dimensions shown, gives

$$\tan 2\phi_p = \frac{\text{opposite}}{\text{adjacent}} = \frac{30 \text{ MPa}}{49 \text{ MPa}} = 0.612$$

However, as the rotation is clockwise the principal stress angle (ϕ_p) will be negative. Changing the sign on ($\tan 2\phi_p$) and solving for angle (ϕ_p) gives a value that is very close to the value found in Example 5 in Sec. 5.2, that is (-15.7°).

$$\tan 2\phi_p = -0.612$$

$$2\phi_p = -31.4^\circ$$

$$\phi_p = -15.7^\circ$$

Similarly, the angle between the line connecting points (75, -30) and (-25, 30) and the positive (τ) axis is the maximum shear stress angle ($2\phi_s$). From Fig. 5.29, this is clockwise or negative rotation, and is 90° more than the principal stress angle ($2\phi_p$).

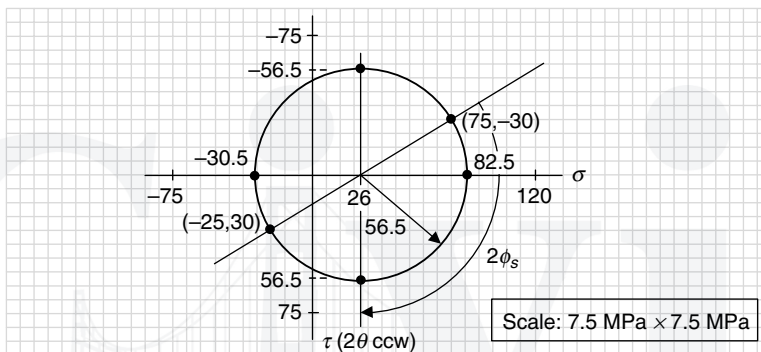

FIGURE 5.29 Maximum shear stress angle (ϕ_s).

From Fig. 5.29, and ($2\phi_p$) found above, the shear stress angle (ϕ_s) becomes

$$2\phi_s = 2\phi_p - 90^\circ = (-31.4^\circ) - 90^\circ = -121.4^\circ$$

$$\phi_s = -60.7^\circ$$

Again, this is the same value of (ϕ_s) found in Example 5 in Sec. 5.2, that is (-60.7°). So the design information found mathematically has been found graphically.

The scale and grid paper used in this graphical process greatly affects the accuracy of the information obtained. For Example 1 in the U.S. Customary system, the data points fell on the grid lines so that the values determined graphically were exactly those found mathematically in Example 5. In contrast, for Example 1 in the SI/metric system, the data points fell between grid lines and with the smaller scale, the values determined were not exact, but certainly within engineering accuracy.

The graphical use of Mohr's circle might seem obsolete in this age of powerful handheld calculators and computers; however, its elegance is timeless and provides an insight not available any other way.

Uniaxial, Biaxial, and Pure Shear Elements. In Chap. 4, three special elements were discussed: *uniaxial*, *biaxial*, and *pure shear*. A uniaxial element has only one nonzero normal stress, (σ_{xx}) or (σ_{yy}), with the shear stress (τ_{xy}) equal to zero. A uniaxial stress element is shown in Fig. 5.30.

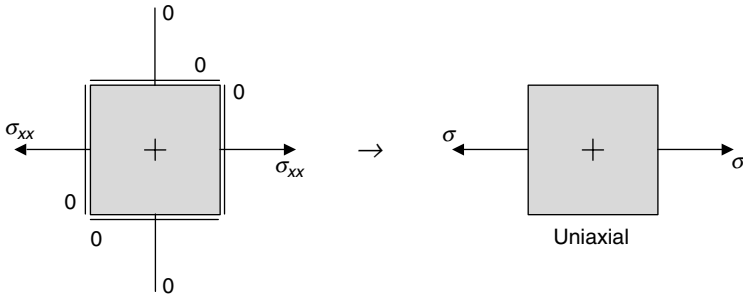

FIGURE 5.30 Uniaxial stress element.

A biaxial element has two nonzero normal stresses (σ_{xx}) and (σ_{yy}); however, the shear stress (τ_{xy}) is zero. A biaxial stress element is shown in Fig. 5.31. Typically, biaxial stress elements occur from pressure loadings.

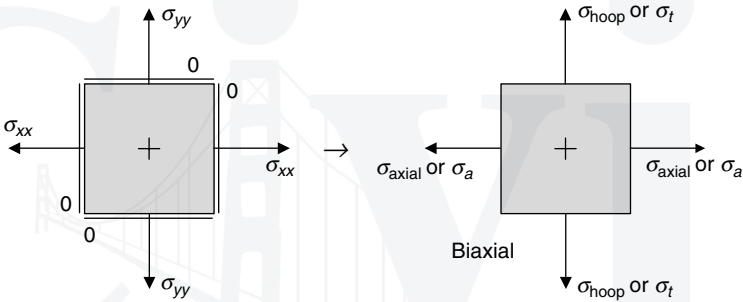

FIGURE 5.31 Biaxial stress element.

A pure shear element has both normal stresses (σ_{xx}) and (σ_{yy}) zero, with a nonzero shear stress (τ_{xy}). A pure shear element is shown in Fig. 5.32.

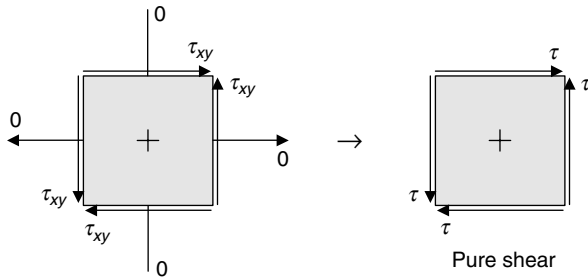

FIGURE 5.32 Pure shear stress element.

Consider the Mohr's circle graphical process for each of these special elements.

Uniaxial Element. For a uniaxial stress element, $\sigma_{xx} = \sigma$, $\sigma_{yy} = 0$, and $\tau_{xy} = 0$, where (σ) is some known stress caused by either a single or combined loading.

The first step in the process is to plot two points; one point having the coordinates (σ_{xx}, τ_{xy}) and the other having the coordinates $(\sigma_{yy}, -\tau_{xy})$, where for a uniaxial stress element these two points are $(\sigma, 0)$ and $(0, 0)$ as in Fig. 5.33.

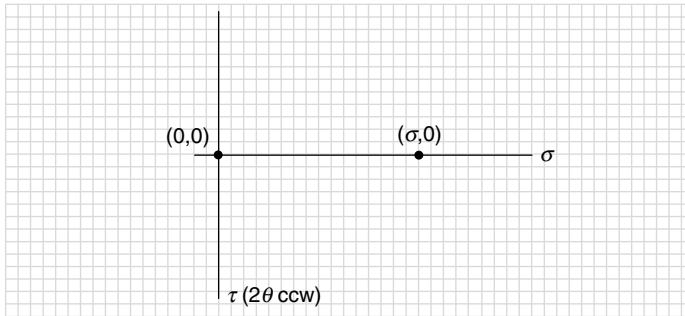

FIGURE 5.33 Plot points (σ_{xx}, τ_{xy}) and $(\sigma_{xx}, -\tau_{xy})$.

A line connecting these two points would cross the (σ) axis at the average stress (σ_{avg}) ; however, for a uniaxial element both points are on the (σ) axis, so the average stress is halfway between, or half the given stress, that is $(\sigma/2)$ as shown in Fig. 5.34.

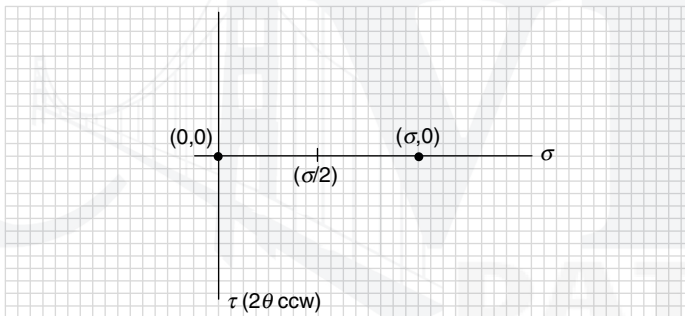

FIGURE 5.34 Connect points to find average stress (σ_{avg}) .

The radius of Mohr's circle will also be half the given stress, that is $(\sigma/2)$. Note that the circle in Fig. 5.35 touches the vertical (τ) axis at the origin of the coordinate system.

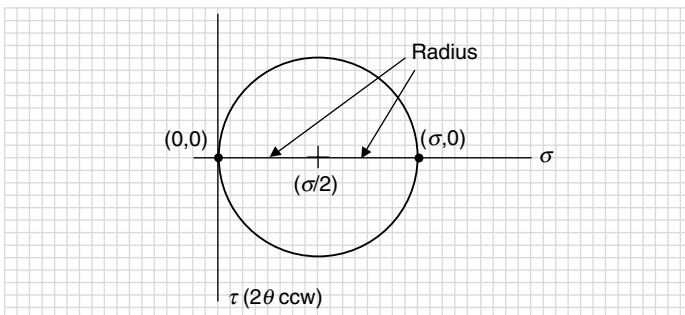

FIGURE 5.35 Draw circle.

Where the circle crosses the (σ) axis on the right, locates the maximum principal stress (σ_1) , and where it crosses on the left, is the minimum principal stress (σ_2) . For the uniaxial element, the maximum principal stress (σ_1) is the given stress (σ) and the minimum principal stress (σ_2) is zero. This means the uniaxial element is actually the principal stress element. Also, the radius of the circle (R) in Fig. 5.36 is the maximum shear stress (τ_{max}) , which here is the same as the average stress $(\sigma/2)$.

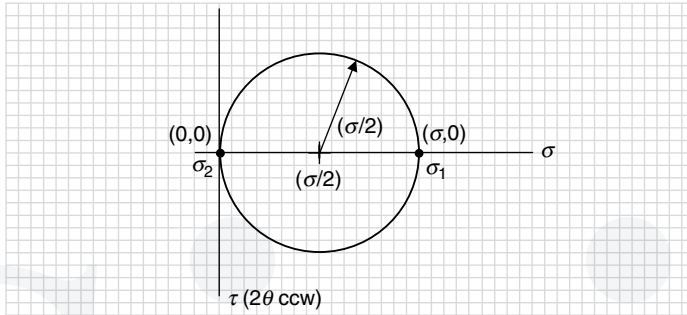

FIGURE 5.36 Principal stresses and radius of circle.

At 90° to the principal stresses are the maximum and minimum shear stresses. For a uniaxial element these shear stresses are equal to the average stress, that is, $(\sigma/2)$ and a minus $(\sigma/2)$, respectively, as shown in Fig. 5.37.

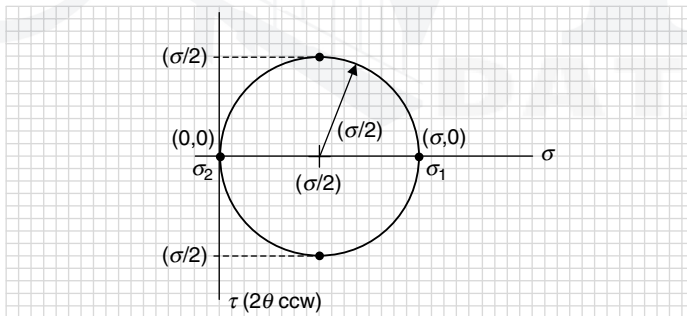

FIGURE 5.37 Maximum and minimum shear stresses.

The angle between the line connecting the points (σ_{xx}, τ_{xy}) and $(\sigma_{xx}, -\tau_{xy})$ and the (σ) axis is the principal stress angle $(2\phi_p)$. Here, as the uniaxial element is the principal stress element, the principal stress angle $(2\phi_p)$ is zero.

The angle between the line connecting the points (σ_{xx}, τ_{xy}) and $(\sigma_{xx}, -\tau_{xy})$ and the positive (τ) axis is the maximum stress angle $(2\phi_s)$. Here, for a uniaxial element, this would be a clockwise, or negative, rotation from the positive (σ) axis and equal to 90° (Fig. 5.38).

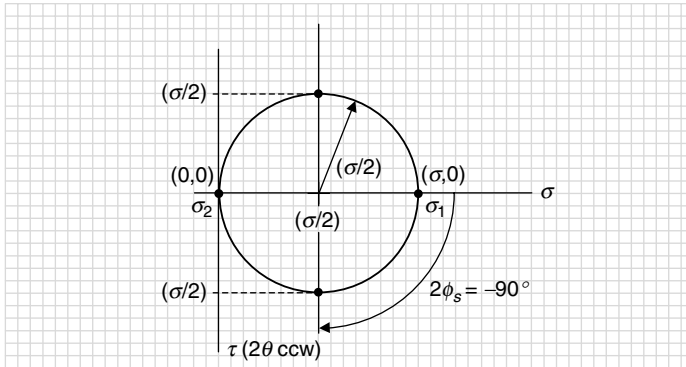

FIGURE 5.38 Maximum shear stress angle (ϕ_s).

From Fig. 5.38, and with $(2\phi_p)$ equal to zero, the shear stress angle (ϕ_s) is

$$2\phi_s = 2\phi_p - 90^\circ = (0^\circ) - 90^\circ = -90^\circ$$

$$\phi_s = -45^\circ$$

Consider the following example where the single normal stress is caused by a loading that produces a uniaxial stress element such as an axial tensile force on a bar.

U.S. Customary	SI/Metric
<p>Example 2. For a normal stress (σ) acting on a uniaxial stress element, find the principal stresses (σ_1) and (σ_2), the maximum and minimum shear stresses (τ_{\max}) and (τ_{\min}), and the special angles (ϕ_p) and (ϕ_s), using the graphical Mohr's circle process shown in Fig. 5.33 through 5.38, where</p> $\sigma = 12 \text{ kpsi}$ <p>solution</p> <p><i>Step 1.</i> Plot points $(0,0)$ and $(12,0)$ as in Fig. 5.33, and locate the center of Mohr's circle, which is the average stress, like that shown in Fig. 5.34.</p> $\sigma_{\text{avg}} = \frac{\sigma}{2} = \frac{12 \text{ kpsi}}{2} = 6 \text{ kpsi}$ <p><i>Step 2.</i> Draw Mohr's circle like that shown in Fig. 5.35 using a radius of (6 kpsi), so that where the circle crosses the (σ) axis it gives the principal stresses like that shown in Fig. 5.36.</p> $\begin{aligned} \sigma_1 &= \sigma_{\text{avg}} + \tau_{\max} = (6 + 6) \text{ kpsi} \\ &= 12 \text{ kpsi} \\ \sigma_2 &= \sigma_{\text{avg}} - \tau_{\max} = (6 - 6) \text{ kpsi} \\ &= 0 \text{ kpsi} \end{aligned}$	<p>Example 2. For a normal stress (σ) acting on a uniaxial stress element, find the principal stresses (σ_1) and (σ_2), the maximum and minimum shear stresses (τ_{\max}) and (τ_{\min}), and the special angles (ϕ_p) and (ϕ_s), using the graphical Mohr's circle process shown in Fig. 1.32 through 1.38, where</p> $\sigma = 84 \text{ MPa}$ <p>solution</p> <p><i>Step 1.</i> Plot points $(0,0)$ and $(84,0)$ as in Fig. 5.33, and locate the center of Mohr's circle, which is the average stress, like that shown in Fig. 5.34.</p> $\sigma_{\text{avg}} = \frac{\sigma}{2} = \frac{84 \text{ MPa}}{2} = 42 \text{ MPa}$ <p><i>Step 2.</i> Draw Mohr's circle like that shown in Fig. 5.35 using a radius of (42 MPa), so that where the circle crosses the (σ) axis it gives the principal stresses like that shown in Fig. 5.36.</p> $\begin{aligned} \sigma_1 &= \sigma_{\text{avg}} + \tau_{\max} = (42 + 42) \text{ MPa} \\ &= 84 \text{ MPa} \\ \sigma_2 &= \sigma_{\text{avg}} - \tau_{\max} = (42 - 42) \text{ MPa} \\ &= 0 \text{ MPa} \end{aligned}$

U.S. Customary	SI/Metric
<p><i>Step 3.</i> From Fig. 5.37, the maximum and minimum shear stresses are shown 90° to the principal stresses, and equal to the average stress.</p> $\tau_{\max} = \sigma_{\text{avg}} = \frac{\sigma}{2} = \frac{12 \text{ kpsi}}{2} = 6 \text{ kpsi}$ $\tau_{\min} = -\tau_{\max} = -6 \text{ kpsi}$ <p><i>Step 4.</i> As the uniaxial stress element is actually the principal stress element, the rotation angle ($2\phi_p$), and therefore the angle (ϕ_p), is zero.</p> $2\phi_p = 0 \text{ or } \phi_p = 0$ <p><i>Step 5.</i> Using Fig. 5.38, the rotation angle ($2\phi_s$) for the maximum shear stress is 90° clockwise, or negative, meaning</p> $2\phi_s = 2\phi_p - 90^\circ = 0 - 90^\circ = -90^\circ$ $\phi_s = -45^\circ$	<p><i>Step 3.</i> From Fig. 5.37, the maximum and minimum shear stresses are shown 90° to the principal stresses, and equal to the average stress.</p> $\tau_{\max} = \sigma_{\text{avg}} = \frac{\sigma}{2} = \frac{84 \text{ MPa}}{2} = 42 \text{ MPa}$ $\tau_{\min} = -\tau_{\max} = -42 \text{ MPa}$ <p><i>Step 4.</i> As the uniaxial stress element is actually the principal stress element, the rotation angle ($2\phi_p$), and therefore the angle (ϕ_p), is zero.</p> $2\phi_p = 0 \text{ or } \phi_p = 0$ <p><i>Step 5.</i> Using Fig. 5.38, the rotation angle ($2\phi_s$) for the maximum shear stress is 90° clockwise, or negative, meaning</p> $2\phi_s = 2\phi_p - 90^\circ = 0 - 90^\circ = -90^\circ$ $\phi_s = -45^\circ$

The important result from this example is that the given stress element is the principal stress element, and that the maximum shear stress in $(\sigma/2)$ acting at 45° .

Biaxial Element. For a biaxial stress element, suppose $\sigma_{xx} = \sigma$, $\sigma_{yy} = 2\sigma$, and $\tau_{xy} = 0$, where (σ) and (2σ) are the axial and hoop stresses in a thin-walled cylinder under an internal pressure.

The first step in the process is to plot two points; one point having the coordinates (σ_{xx}, τ_{xy}) and the other having the coordinates $(\sigma_{yy}, -\tau_{xy})$, where for a biaxial stress element these two points are $(\sigma, 0)$ and $(2\sigma, 0)$. This is shown in Fig. 5.39.

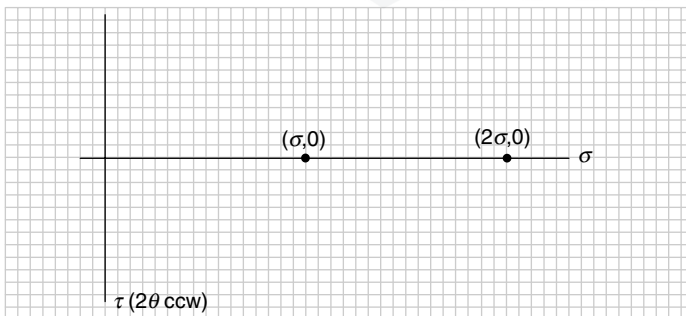

FIGURE 5.39 Plot points (σ_{xx}, t_{xy}) and $(\sigma_{xx}, -t_{xy})$.

A line connecting these two points would cross the (σ) axis at the average stress (σ_{avg}) ; however, for a biaxial element both points are on the (σ) axis, so the average stress is halfway between, that is, $(3\sigma/2)$ as in Fig. 5.40.

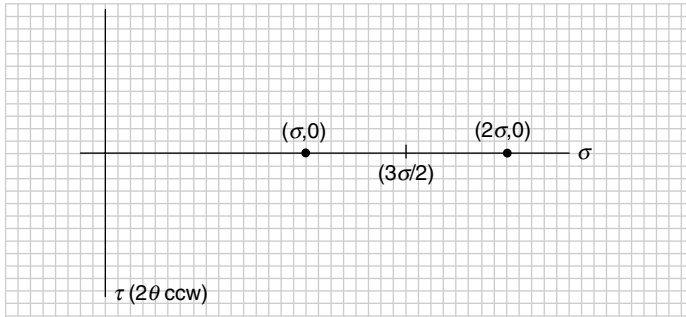

FIGURE 5.40 Connect points to find average stress (σ_{avg}).

In Fig. 5.41 the radius of Mohr's circle will be half the axial stress, that is $(\sigma/2)$.

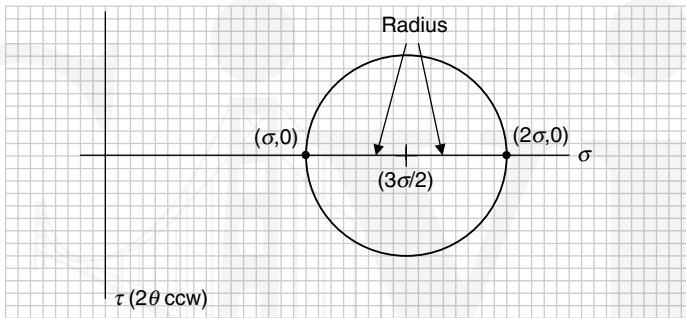

FIGURE 5.41 Draw circle.

Where the circle crosses the (σ) axis on the right, locates the maximum principal stress (σ_1), and where it crosses on the left, is the minimum principal stress (σ_2). For the biaxial element, the maximum principal stress is (2σ) and the minimum principal stress is (σ) . This means the biaxial element, like the uniaxial element, is actually the principal stress element. Also, the radius of the circle (R) is the maximum shear stress (τ_{max}) as shown in Fig. 5.42.

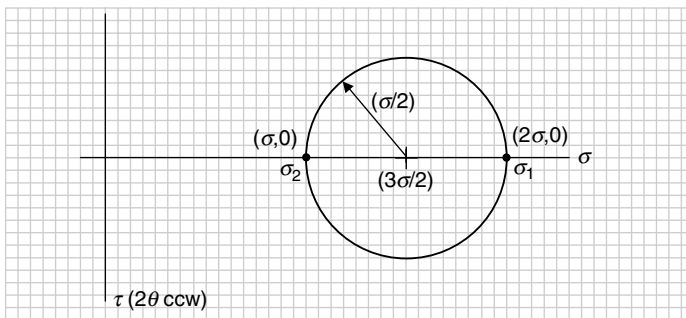

FIGURE 5.42 Principal stresses and radius of circle.

At 90° to the principal stresses are the maximum and minimum shear stresses. For a biaxial element these shear stresses are equal to $(\sigma/2)$ and a minus $(\sigma/2)$, respectively, as shown in Fig. 5.43.

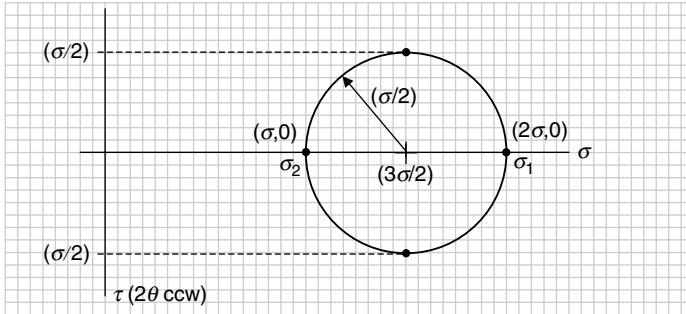

FIGURE 5.43 Maximum and minimum shear stresses.

The angle between the line connecting the points (σ_{xx}, τ_{xy}) and $(\sigma_{xx}, -\tau_{xy})$ and the (σ) axis is the principal stress angle $(2\phi_p)$. Here, as the biaxial element is the principal stress element, the principal stress angle $(2\phi_p)$ is zero.

The angle between the line connecting the points (σ_{xx}, τ_{xy}) and $(\sigma_{xx}, -\tau_{xy})$ and the positive (τ) axis is the maximum stress angle $(2\phi_s)$. Here, as in Fig. 5.44 for a biaxial element, this would be a clockwise, or negative, rotation from the positive (σ) axis and equal to 90° .

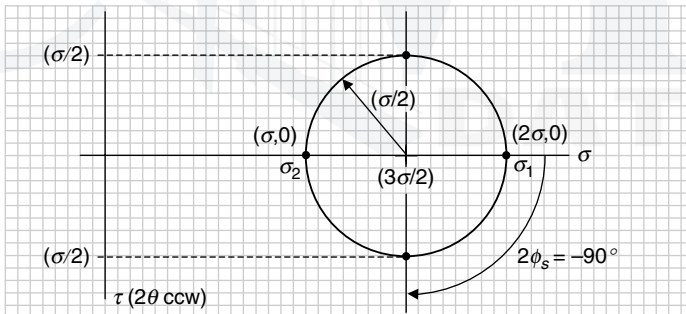

FIGURE 5.44 Maximum shear stress angle (ϕ_s) .

From Fig. 5.44, and with $(2\phi_p)$ equal to zero, the shear stress angle (ϕ_s) is

$$2\phi_s = 2\phi_p - 90^\circ = (0^\circ) - 90^\circ = -90^\circ$$

$$\phi_s = -45^\circ$$

Consider the following example where the two normal stresses are the axial and hoop stresses for a thin-walled cylinder under an internal pressure.

U.S. Customary	SI/Metric
<p>Example 3. For normal stresses (σ) and (2σ) acting on a biaxial stress element, find the principal stresses (σ_1) and (σ_2), the maximum and minimum shear stresses (τ_{\max}) and (τ_{\min}), and the special angles (ϕ_p) and (ϕ_s), using the graphical Mohr's circle process shown in Fig. 5.39 through 5.44, where</p> $\sigma = 8 \text{ kpsi and } 2\sigma = 16 \text{ kpsi}$ <p>solution</p> <p><i>Step 1.</i> Plot points (8,0) and (16,0) as in Fig. 5.39, and locate the center of Mohr's circle, which is the average stress, like that shown in Fig. 5.40.</p> $\begin{aligned}\sigma_{\text{avg}} &= \frac{\sigma + 2\sigma}{2} = \frac{(8 + 16) \text{ kpsi}}{2} \\ &= \frac{24 \text{ kpsi}}{2} = 12 \text{ kpsi}\end{aligned}$ <p><i>Step 2.</i> Draw Mohr's circle like that shown in Fig. 5.41 using a radius of (4 kpsi), so that where the circle crosses the (σ) axis it gives the principal stresses like that shown in Fig. 5.42.</p> $\begin{aligned}\sigma_1 &= \sigma_{\text{avg}} + \tau_{\max} = (12 + 4) \text{ kpsi} \\ &= 16 \text{ kpsi} \\ \sigma_2 &= \sigma_{\text{avg}} - \tau_{\max} = (12 - 4) \text{ kpsi} \\ &= 8 \text{ kpsi}\end{aligned}$ <p><i>Step 3.</i> From Fig. 5.43, the maximum and minimum shear stresses are shown 90° to the principal stresses, and equal to the following value.</p> $\begin{aligned}\tau_{\max} &= \frac{\sigma}{2} = \frac{8 \text{ kpsi}}{2} = 4 \text{ kpsi} \\ \tau_{\min} &= -\tau_{\max} = -4 \text{ kpsi}\end{aligned}$ <p><i>Step 4.</i> As the biaxial stress element is actually the principal stress element, the rotation angle ($2\phi_p$), and therefore the angle (ϕ_p), is zero.</p> $2\phi_p = 0 \quad \text{or} \quad \phi_p = 0$ <p><i>Step 5.</i> Using Fig. 5.44, the rotation angle ($2\phi_s$) for the maximum shear stress is 90° clockwise, or negative, meaning</p> $\begin{aligned}2\phi_s &= 2\phi_p - 90^\circ = 0 - 90^\circ = -90^\circ \\ \phi_s &= -45^\circ\end{aligned}$	<p>Example 3. For normal stresses (σ) and (2σ) acting on a biaxial stress element, find the principal stresses (σ_1) and (σ_2), the maximum and minimum shear stresses (τ_{\max}) and (τ_{\min}), and the special angles (ϕ_p) and (ϕ_s), using the graphical Mohr's circle process shown in Fig. 5.39 through 5.44, where</p> $\sigma = 56 \text{ MPa and } 2\sigma = 112 \text{ MPa}$ <p>solution</p> <p><i>Step 1.</i> Plot points (56,0) and (112,0) as in Fig. 5.39, and locate the center of Mohr's circle, which is the average stress, like that shown in Fig. 5.40.</p> $\begin{aligned}\sigma_{\text{avg}} &= \frac{\sigma + 2\sigma}{2} = \frac{(56 + 112) \text{ MPa}}{2} \\ &= \frac{168 \text{ MPa}}{2} = 84 \text{ MPa}\end{aligned}$ <p><i>Step 2.</i> Draw Mohr's circle like that shown in Fig. 5.41 using a radius of (28 MPa), so that where the circle crosses the (σ) axis it gives the principal stresses like that shown in Fig. 5.42.</p> $\begin{aligned}\sigma_1 &= \sigma_{\text{avg}} + \tau_{\max} = (84 + 28) \text{ MPa} \\ &= 112 \text{ MPa} \\ \sigma_2 &= \sigma_{\text{avg}} - \tau_{\max} = (84 - 28) \text{ MPa} \\ &= 56 \text{ MPa}\end{aligned}$ <p><i>Step 3.</i> From Fig. 5.43, the maximum and minimum shear stresses are shown 90° to the principal stresses, and equal to the following value.</p> $\begin{aligned}\tau_{\max} &= \frac{\sigma}{2} = \frac{56 \text{ MPa}}{2} = 28 \text{ MPa} \\ \tau_{\min} &= -\tau_{\max} = -28 \text{ MPa}\end{aligned}$ <p><i>Step 4.</i> As the biaxial stress element is actually the principal stress element, the rotation angle ($2\phi_p$), and therefore the angle (ϕ_p), is zero.</p> $2\phi_p = 0 \quad \text{or} \quad \phi_p = 0$ <p><i>Step 5.</i> Using Fig. 5.44, the rotation angle ($2\phi_s$) for the maximum shear stress is 90° clockwise, or negative, meaning</p> $\begin{aligned}2\phi_s &= 2\phi_p - 90^\circ = 0 - 90^\circ = -90^\circ \\ \phi_s &= -45^\circ\end{aligned}$

The important result from this example is that the given stress element is the principal stress element, and that the maximum shear stress is $(\sigma/2)$ acting at 45° .

Consider now the last of the three special elements, the pure shear element.

Pure Shear Element. For a pure shear stress element, suppose $\sigma_{xx} = 0$, $\sigma_{yy} = 0$, and $\tau_{xy} = \tau$, where (τ) is a known stress caused by either a single loading or a combination of loadings.

The first step in the process is to plot two points; one point having the coordinates (σ_{xx}, τ_{xy}) and the other having the coordinates $(\sigma_{yy}, -\tau_{xy})$, where for a pure shear stress element these two points are $(0, \tau)$ and $(0, -\tau)$ as shown in Fig. 5.45.

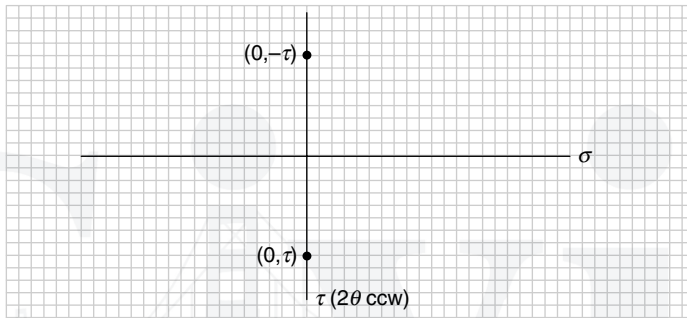

FIGURE 5.45 Plot points (σ_{xx}, τ_{xy}) and $(\sigma_{yy}, -\tau_{xy})$.

A line connecting these two points would cross the (σ) axis at the average stress (σ_{avg}) ; however, for a pure shear element both points are on the (τ) axis, so the average stress is halfway between, that is (0) as shown in Fig. 5.46.

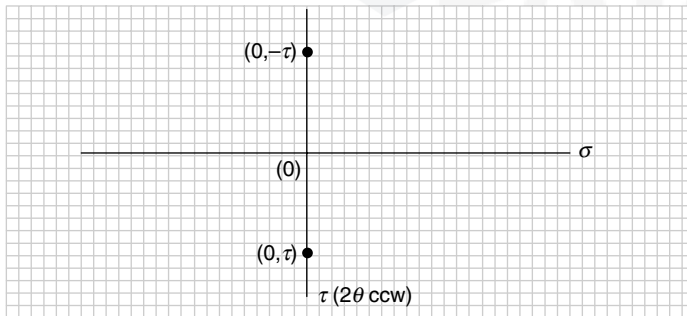

FIGURE 5.46 Connect points to find average stress (σ_{avg}) .

The radius of Mohr's circle will be the shear stress, that is (τ) as shown in Fig. 5.47.

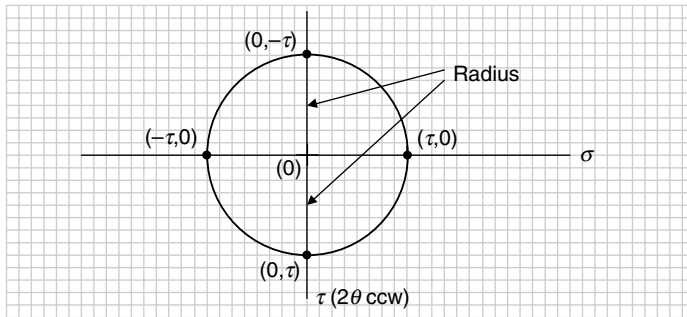

FIGURE 5.47 Draw circle.

Where the circle crosses the (σ) axis on the right locates the maximum principal stress (σ_1), and where it crosses on the left is the minimum principal stress (σ_2). For the pure shear element, the maximum principal stress is (τ) and the minimum principal stress is ($-\tau$). This means the pure element, unlike the uniaxial and biaxial elements, is actually the maximum shear stress element as in Fig. 5.48, where the radius is the maximum shear stress (τ_{\max}).

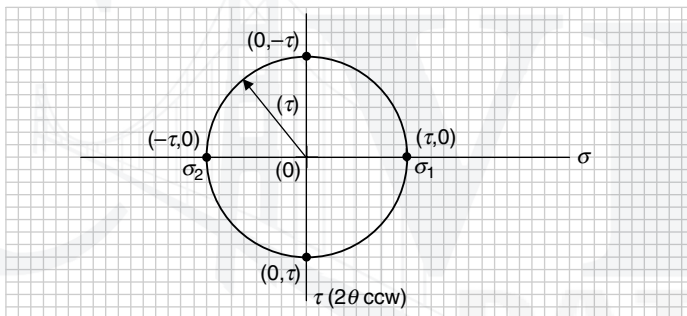

FIGURE 5.48 Principal stresses and radius of circle.

At 90° to the principal stresses are the maximum and minimum shear stresses. For a pure shear element these shear stresses are equal to (τ) and a minus ($-\tau$), respectively, as shown in Fig. 5.49.

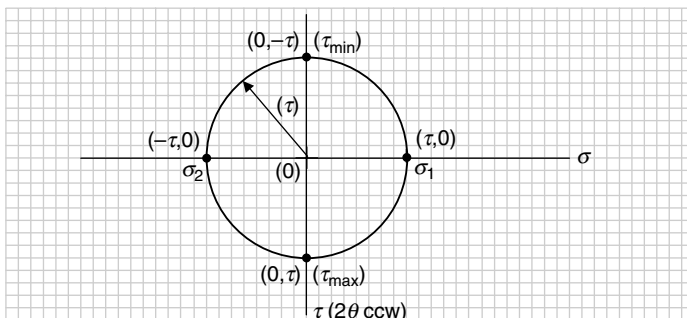

FIGURE 5.49 Maximum and minimum shear stresses.

The angle between the line connecting the points (σ_{xx}, τ_{xy}) and $(\sigma_{xx}, -\tau_{xy})$ and the (τ) axis is the maximum shear stress angle $(2\phi_s)$. Here, as the pure shear element is the maximum shear stress element, the maximum shear stress angle $(2\phi_s)$ is zero.

The angle between the line connecting the points (σ_{xx}, τ_{xy}) and $(\sigma_{xx}, -\tau_{xy})$ and the positive (σ) axis is the principal stress angle $(2\phi_p)$. Here, for a pure shear element, this would be a counterclockwise, or positive, rotation from the (τ) axis and equal to 90° (Fig. 5.50).

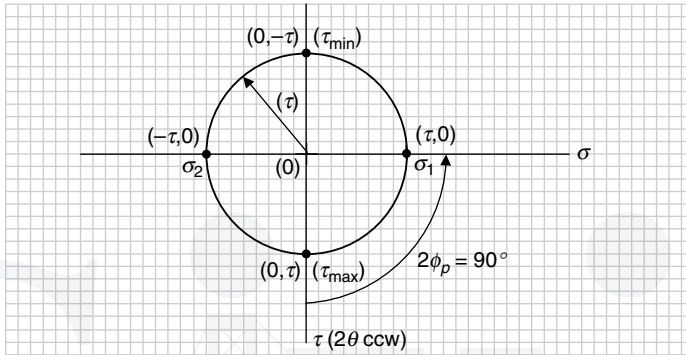

FIGURE 5.50 Maximum principal stress angle (ϕ_p) .

From Fig. 5.50, with $(2\phi_s)$ equal to zero, the principal stress angle (ϕ_p) is

$$2\phi_p = 90^\circ \rightarrow \phi_p = 45^\circ$$

Consider the following example where the shear stress (τ) is caused by either torsion or shear due to bending, or both, but where no normal stresses are present.

U.S. Customary	SI/Metric
<p>Example 4. For the shear stress (τ) acting on a pure shear stress element, find the principal stresses (σ_1) and (σ_2), maximum and minimum shear stresses (τ_{max}) and (τ_{min}), and the special angles (ϕ_p) and (ϕ_s), using the graphical Mohr's circle process shown in Fig. 5.45 through 5.45, where</p> <p style="text-align: center;">$\tau = 10 \text{ kpsi}$</p> <p>solution</p> <p><i>Step 1.</i> Plot points $(0,10)$ and $(0,-10)$ as in Fig. 5.45, and locate the center of Mohr's circle, which is the average stress, like that shown in Fig. 5.46.</p> $\sigma_{avg} = \frac{\sigma_{xx} + \sigma_{yy}}{2} = \frac{(0 + 0) \text{ kpsi}}{2} = 0 \text{ kpsi}$	<p>Example 4. For the shear stress (τ) acting on a pure shear stress element, find the principal stresses (σ_1) and (σ_2), maximum and minimum shear stresses (τ_{max}) and (τ_{min}), and the special angles (ϕ_p) and (ϕ_s), using the graphical Mohr's circle process shown in Figs. 5.44 through 5.45, where</p> <p style="text-align: center;">$\tau = 70 \text{ MPa}$</p> <p>solution</p> <p><i>Step 1.</i> Plot points $(0,70)$ and $(0,-70)$ as in Fig. 5.45, and locate the center of Mohr's circle, which is the average stress, like that shown in Fig. 5.46.</p> $\sigma_{avg} = \frac{\sigma_{xx} + \sigma_{yy}}{2} = \frac{(0 + 0) \text{ MPa}}{2} = 0 \text{ MPa}$

U.S. Customary	SI/Metric
<p><i>Step 2.</i> Draw Mohr's circle like that shown in Fig. 5.47 using a radius of (10 kpsi), so that where the circle crosses the (σ) axis it gives the principal stresses like that shown in Fig. 5.48.</p> $\sigma_1 = \sigma_{\text{avg}} + \tau_{\text{max}} = (0 + 10) \text{ kpsi}$ $= 10 \text{ kpsi}$ $\sigma_2 = \sigma_{\text{avg}} - \tau_{\text{max}} = (0 - 10) \text{ kpsi}$ $= -10 \text{ kpsi}$ <p><i>Step 3.</i> From Fig. 5.49, the maximum and minimum shear stresses are shown 90° to the principal stresses, and equal to the shear stress (τ).</p> $\tau_{\text{max}} = \tau = 10 \text{ kpsi}$ $\tau_{\text{min}} = -\tau_{\text{max}} = -10 \text{ kpsi}$ <p><i>Step 4.</i> As the pure shear stress element is actually the maximum shear stress element, the rotation angle ($2\phi_s$) and therefore the angle (ϕ_s), is zero.</p> $2\phi_s = 0 \rightarrow \phi_s = 0$ <p><i>Step 5.</i> Using Fig. 5.50, the rotation angle ($2\phi_p$) for the principal stress element is 90° counterclockwise, or positive, meaning</p> $2\phi_p = 90^\circ \rightarrow \phi_p = 45^\circ$	<p><i>Step 2.</i> Draw Mohr's circle like that shown in Fig. 5.47 using a radius of (70 MPa), so that where the circle crosses the (σ) axis it gives the principal stresses like that shown in Fig. 5.48.</p> $\sigma_1 = \sigma_{\text{avg}} + \tau_{\text{max}} = (0 + 70) \text{ MPa}$ $= 70 \text{ MPa}$ $\sigma_2 = \sigma_{\text{avg}} - \tau_{\text{max}} = (0 - 70) \text{ MPa}$ $= -70 \text{ MPa}$ <p><i>Step 3.</i> From Fig.5.49, the maximum and minimum shear stresses are shown 90° to the principal stresses, and equal to the shear stress (τ).</p> $\tau_{\text{max}} = \tau = 70 \text{ MPa}$ $\tau_{\text{min}} = -\tau_{\text{max}} = -70 \text{ MPa}$ <p><i>Step 4.</i> As the pure shear stress element is actually the maximum shear stress element, the rotation angle ($2\phi_s$) and therefore the angle (ϕ_s), is zero.</p> $2\phi_s = 0 \rightarrow \phi_s = 0$ <p><i>Step 5.</i> Using Fig. 5.50, the rotation angle ($2\phi_p$) for the principal stress element is 90° counterclockwise, or positive, meaning</p> $2\phi_p = 90^\circ \rightarrow \phi_p = 45^\circ$

The important result from this example is that the given element is the maximum shear stress element, and that the principal stresses are (τ) and ($-\tau$) acting at 45° .

Triaxial Stress. For a plane stress element, the maximum shear stress (τ_{max}) can be related to the principal stresses (σ_1) and (σ_2) by the relationship in Eq. (5.19).

$$\tau_{\text{max}} = \frac{\sigma_1 - \sigma_2}{2} \quad (5.19)$$

Equation (5.19) simply says that the distance between the principal stresses divided by two is the radius of Mohr's circle that is the maximum shear stress. However, there is a third principal stress (σ_3) acting perpendicular, or normal, to the plane stress element, so that Eq. (5.19) must be modified to become Eq. (5.20), where

$$\tau_{\text{max}} = \frac{\sigma_1 - \sigma_3}{2} \quad (5.20)$$

Even if this third principal stress is zero, Eq. (5.20) will yield a larger maximum shear stress than Eq. (5.19), unless the minimum principal stress (σ_2) is negative, in which case

Eq. (5.19) would still yield the maximum value for the maximum shear stress. In any case, this stress element is called a triaxial stress element.

The situation where Eq. (5.20) must be applied is when the third principal stress (σ_3) is less than the minimum principal stress (σ_2). For example, if the third principal stress is a negative value, such as an internal pressure (p_i) on the inside of a thin-walled vessel, the principal stresses (σ_1) and (σ_2) are both positive, and as already seen earlier form a biaxial stress element, then Eq. (5.20) will yield a much larger value for the maximum shear stress than Eq. (5.19).

This can be seen graphically using the Mohr's circle process, where the third principal stress (σ_3) is added as a point on the (σ) axis. As can be seen in Fig. 5.51, if (σ_3) is less than (σ_2), and particularly if it is negative, then the radius of Mohr's circle represented by Eq. (5.20) is much larger than the radius represented by Eq. (5.19).

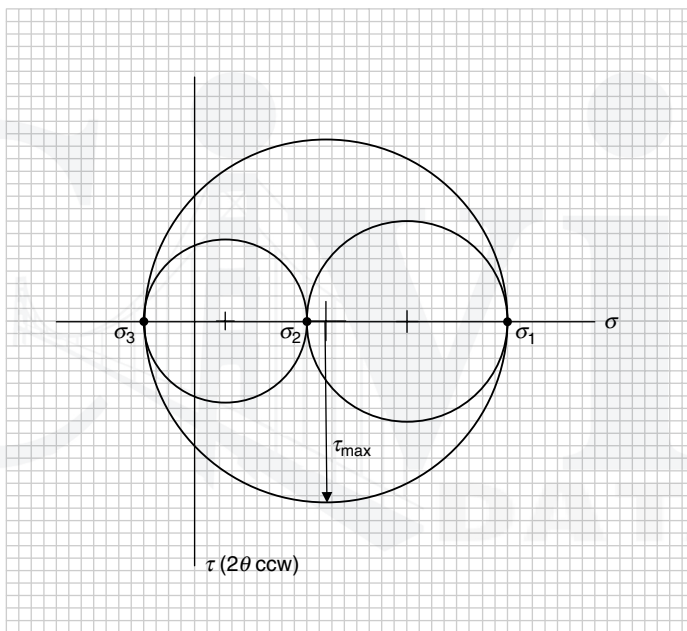

FIGURE 5.51 Mohr's circle for a triaxial stress element.

Notice that there is a circle represented by the difference between the principal stresses (σ_1) and (σ_2), a circle represented by the difference between the principal stresses (σ_2) and (σ_3), but the biggest circle is represented by the difference between the principal stresses (σ_1) and (σ_3) that is the maximum shear stress (τ_{\max}). The importance of finding the maximum shear stress, especially for ductile materials, will be discussed shortly. For now, it is just necessary to keep in mind what might be taking place normal to a plane stress element, even if this third stress is zero.

Let us look at a previous example to see how Eq. (5.20) comes into play.

Consider the following example where the two normal stresses are the axial and hoop stresses for a thin-walled cylinder under an internal pressure (p_i).

U.S. Customary	SI/Metric
<p>Example 5. For the biaxial stresses (σ) and (2σ) given in Example 3 that are the principal stresses (σ_1) and (σ_2), find the maximum shear stress (τ_{\max}) if the element is actually a triaxial stress element using Eq. (5.20), where</p> $2\sigma = 16 \text{ kpsi} = \sigma_1$ $\sigma = 8 \text{ kpsi} = \sigma_2$ $p_i = -4 \text{ kpsi} = \sigma_3$ <p>solution.</p> <p><i>Step 1.</i> Using Eq. (5.20), the maximum shear stress becomes</p> $\tau_{\max} = \frac{\sigma_1 - \sigma_3}{2} = \frac{[16 - (-4)] \text{ kpsi}}{2}$ $= \frac{20 \text{ kpsi}}{2} = 10 \text{ kpsi}$ <p><i>Step 2.</i> Compare this value for the maximum shear stress with that found in Example 8, where</p> $\tau_{\max} = \frac{\sigma}{2} = \frac{8 \text{ kpsi}}{2} = 4 \text{ kpsi}$	<p>Example 5. For the biaxial stresses (σ) and (2σ) given in Example 3 that are the principal stresses (σ_1) and (σ_2), find the maximum shear stress (τ_{\max}) if the element is actually a triaxial stress element using Eq. (5.20), where</p> $2\sigma = 112 \text{ MPa} = \sigma_1$ $\sigma = 56 \text{ MPa} = \sigma_2$ $p_i = -28 \text{ MPa} = \sigma_3$ <p>solution.</p> <p><i>Step 1.</i> Using Eq. (5.20), the maximum shear stress becomes</p> $\tau_{\max} = \frac{\sigma_1 - \sigma_3}{2} = \frac{[112 - (-28)] \text{ MPa}}{2}$ $= \frac{140 \text{ MPa}}{2} = 70 \text{ MPa}$ <p><i>Step 2.</i> Compare this value for the maximum shear stress with that found in Example 8, where</p> $\tau_{\max} = \frac{\sigma}{2} = \frac{56 \text{ MPa}}{2} = 28 \text{ MPa}$

Notice that the maximum shear stress found using Eq. (5.20) is two and a half times the maximum shear stress found in Example 8 where the stress element was treated as a biaxial stress element. This is obviously a nontrivial difference and cannot be ignored in a design.

Without providing the proof, the maximum shear stress found using Eq. (5.20) acts on a plane rotated 45° about the maximum principal axis (σ_1). This means the material tears at a 45° angle in the cross section rather than straight across the cross section. This is seen in actual failures and is a telltale sign that the vessel failed due to excessive pressure.

Three Dimensional Stress. While it is difficult to imagine a combination of loadings that would produce a set of stresses, three normal ($\sigma_{xx}, \sigma_{yy}, \sigma_{zz}$) and three shear stresses ($\tau_{xy}, \tau_{xz}, \tau_{yz}$) acting on the six sides of an element, the three associated principal stresses ($\sigma_1, \sigma_2, \sigma_3$) could be found by solving the following cubic equation. (A trial-and-error approach works well.)

$$\sigma^3 - (\sigma_{xx} + \sigma_{yy} + \sigma_{zz})\sigma^2 + (\sigma_{xx}\sigma_{yy} + \sigma_{xx}\sigma_{zz} + \sigma_{yy}\sigma_{zz} - \tau_{xy}^2 - \tau_{xz}^2 - \tau_{yz}^2)\sigma - (\sigma_{xx}\sigma_{yy}\sigma_{zz} + 2\tau_{xy}\tau_{xz}\tau_{yz} - \sigma_{xx}\tau_{yz}^2 - \sigma_{yy}\tau_{xz}^2 - \sigma_{zz}\tau_{xy}^2) = 0$$

If these three principal stresses are ordered such that ($\sigma_1 > \sigma_2 > \sigma_3$), then the maximum shear stress is given by Eq. (5.20), repeated here.

$$\tau_{\max} = \frac{\sigma_1 - \sigma_3}{2} \quad (5.20)$$

Again, it is very unusual to be faced with having to analyze an element with this level of complexity, but it is comforting to know that the methods, both analytical and graphical, presented in this section, could be used if necessary.

CHAPTER 6

STATIC DESIGN AND COLUMN BUCKLING

6.1 STATIC DESIGN

The question now arises as to whether the values of the principal stresses (σ_1) and (σ_2) and the maximum and minimum shear stresses (τ_{\max}) and (τ_{\min}) found for a machine element in Chap. 5, either mathematically or using the Mohr's circle graphical process, represent a safe operating condition. Depending on whether the material used for the machine element can be considered ductile or brittle, the most commonly accepted criteria, or theories, predicting that a design is safe under static conditions will be presented. The most common ways to define a factor-of-safety (n) for a machine element will also be presented, again based on whether the material being used is ductile or brittle.

Static Design Coordinate System. For the static design theories that follow, all the theories can be represented by mathematical expressions; however, as was the case with Mohr's circle, a graphical picture of these expressions provides a significant insight into what the theory really means in terms of predicting that a design is safe under static conditions. Figure 6.1 shows the coordinate system that will be used, where the horizontal axis is the maximum principal stress (σ_1) and the vertical axis is the minimum principal stress (σ_2).

For ductile materials, the yield strength (S_y) in tension and in compression are relatively equal in magnitude, whereas for brittle materials the ultimate compressive strength (S_{uc}) is significantly greater in magnitude than the ultimate tensile strength (S_{ut}). Figure 6.1 reflects the difference between the yield and ultimate strengths, and the difference between the magnitudes of the ultimate tensile and compressive strengths.

(Note that capital S is used for the term *strength* of a material, whereas the Greek letter σ is used for the calculated normal stresses and the principal stresses and τ for the calculated shear stresses and the maximum and minimum shear stresses.)

The four quadrants of this coordinate system, labeled I, II, III, and IV as shown, represent the possible combinations of the principal stresses (σ_1, σ_2). As it is usually assumed that the maximum principal stress (σ_1) is always greater than or at least equal to the minimum principal stress (σ_2), combinations in the second (II) quadrant where (σ_1) would be negative and (σ_2) would be positive, are not possible. However, the graphical representations of the analytical expressions will include the second quadrant just from a mathematical standpoint. Primarily, the most common combinations are in the first (I) quadrant where (σ_1) and (σ_2) are both positive and in the fourth (IV) quadrant where (σ_1) is positive and (σ_2) is negative. Combinations can occur in the third (III) quadrant where (σ_1) is negative, however (σ_2) must be equally or more negative.

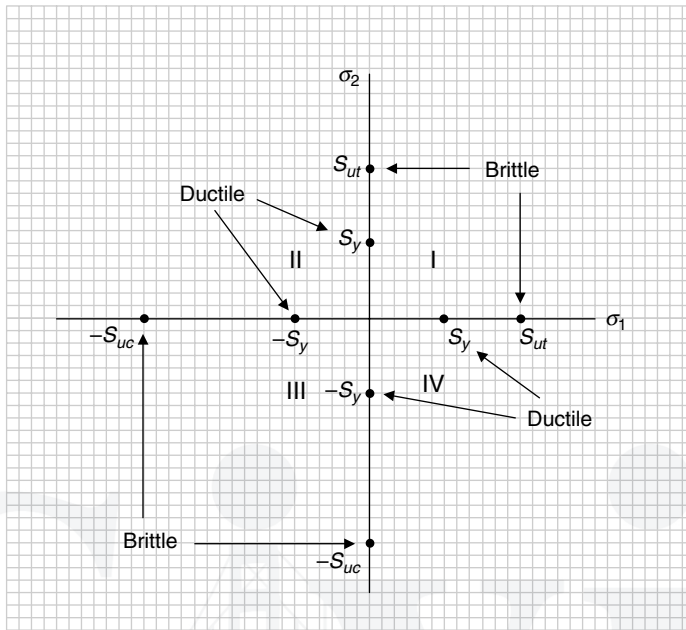

FIGURE 6.1 Static design coordinate system.

6.1.1 Static Design for Ductile Materials

A material is considered ductile if it exhibits a true strain at fracture that is greater than 5 percent. Failure of a machine element made of a ductile material is usually associated with the element changing shape, meaning it has visible yielding. Therefore, the important strength for determining if the design of the machine element under static conditions is safe is the yield strength (S_y). As mentioned earlier, the yield strength in tension and compression for a ductile material are relatively the same, so the compressive yield strength is ($-S_y$).

For ductile materials, there are three static design theories that fit the available experimental data on whether the combinations of (σ_1, σ_2) for a machine element are safe:

- Maximum-normal-stress theory
- Maximum-shear-stress theory
- Distortion-energy theory

Each of these three theories will be discussed separately, followed by the appropriate recommendations as to which theory is best for every possible combination of the principal stresses (σ_1, σ_2) . Remember, combinations in the second (II) quadrant are impossible if it is assumed that the maximum principal stress (σ_1) is always greater than or at least equal to the minimum principal stress (σ_2), even though the mathematical expressions and graphical representations that will be shown allow this combination.

Maximum-Normal-Stress Theory. The square in Fig. 6.2 represented by the tensile and compressive yield strengths (S_y) and ($-S_y$) shown in Fig. 6.1 is the graphical representation of the maximum-normal-stress theory. Any combination of the principal stresses (σ_1, σ_2) that falls inside this square represents a safe design, and any combination that falls outside the square is unsafe.

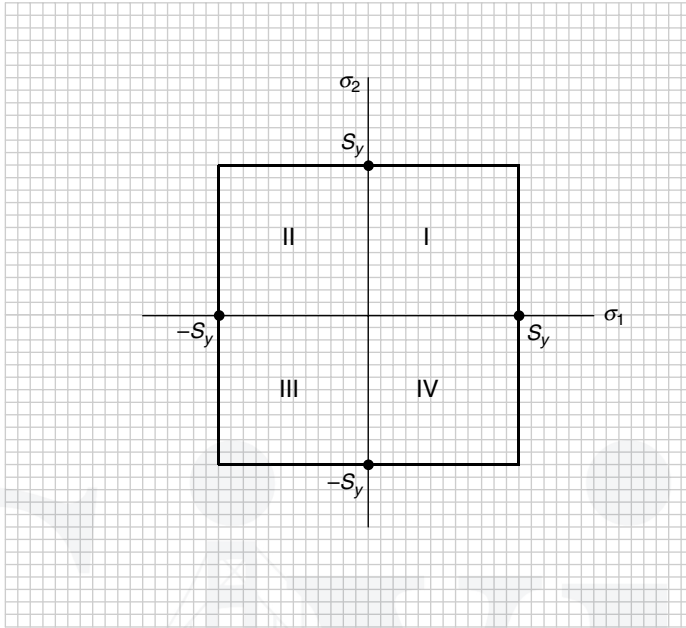

FIGURE 6.2 Maximum-normal-stress theory (ductile).

The mathematical expressions representing a safe design according to the maximum-normal-stress theory are given in Eq. (6.1).

$$\sigma_1 < S_y \quad \text{or} \quad \sigma_2 > -S_y \quad (6.1)$$

where the first expression in Eq. (6.1) results in a boundary at the vertical line, ($\sigma_1 = S_y$), and the second expression results in a boundary at the horizontal line at ($\sigma_2 = -S_y$). The boundaries at the vertical line, ($\sigma_1 = -S_y$), and the horizontal line, ($\sigma_2 = S_y$), are permissible by mathematics but are not relevant to the possible combinations of (σ_1, σ_2).

The factor-of-safety (n) for this theory is given in Eq. (6.2) that replaces the inequality signs in Eq. (6.1) with equals signs and are then rearranged to give

$$\frac{\sigma_1}{S_y} = \frac{1}{n} \quad \text{or} \quad \frac{\sigma_2}{-S_y} = \frac{1}{n} \quad (6.2)$$

The factor-of-safety (n) in either expression of Eq. (6.2) represents how close the combination of the principal stresses (σ_1, σ_2) is to the boundary defined by the theory. A factor-of-safety much greater than 1 means that the (σ_1, σ_2) combination is not only inside the boundary of the theory but far from it. A factor-of-safety equal to (1) means that the combination is on the boundary. Any factor-of-safety that is less than 1 is outside the boundary and represents an unsafe static loading condition.

Maximum-Shear-Stress Theory. It was shown in a previous section that the maximum shear stress (τ_{\max}) is related to the principal stresses (σ_1) and (σ_2) by the expression given

in Eq. (6.3).

$$\tau_{\max} = \frac{\sigma_1 - \sigma_2}{2} \quad (6.3)$$

From the tensile test that determines the yield strength (S_y), the maximum principal stress (σ_1) is equal to the yield strength and the minimum principal stress (σ_2) is zero. So the maximum shear stress in Eq. (6.3) becomes

$$\tau_{\max} = \frac{\sigma_1 - \sigma_2}{2} = \frac{S_y - 0}{2} = \frac{S_y}{2} = S_{sy} \quad (6.4)$$

where (S_{sy}) is the yield strength in shear of the material.

Eq. (6.4) can be used to establish the boundary of the maximum-shear-stress theory, given mathematically in the second expression of Eq. (6.5) as

$$\frac{\sigma_1 - \sigma_2}{2} < \frac{S_y}{2} \rightarrow \sigma_1 - \sigma_2 < S_y \quad (6.5)$$

where the straight lines at 45° , one in the fourth (IV) quadrant and one only allowed mathematically in the second (II) quadrant, represents this theory graphically.

As the maximum-shear-stress theory by itself would allow combinations of the principal stresses (σ_1, σ_2) to be outside a reasonable boundary, the horizontal and vertical lines in both the first (I) and third (III) quadrants of Fig. 6.3, which represent the maximum-normal-stress theory, create a closed region defining the safe combinations of the principal stresses (σ_1, σ_2). Remember, combinations in the second (II) quadrant are impossible if it is assumed that the maximum principal stress (σ_1) is greater than or at least equal to the

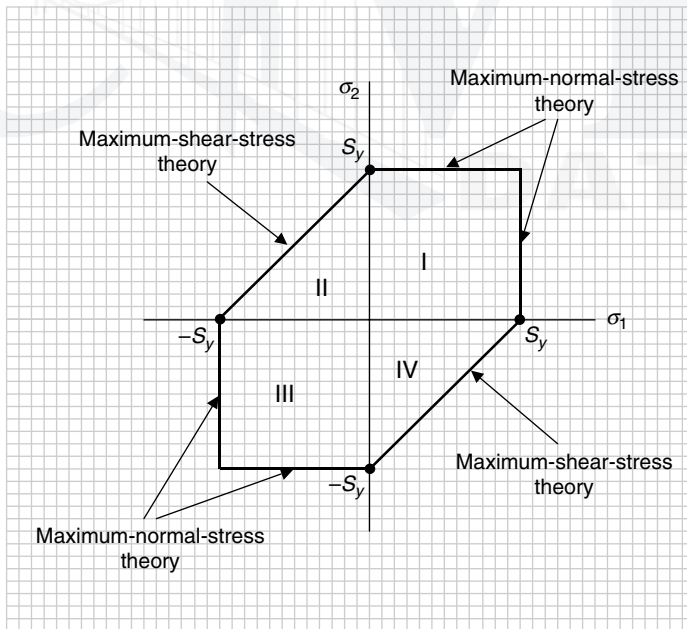

FIGURE 6.3 Maximum-shear-stress theory (ductile).

minimum principal stress (σ_2). Also, combinations in the third (III) quadrant require that the minimum principal stress (σ_2) be at least equal to or more negative than the maximum principal stress (σ_1).

The factor-of-safety (n) for this theory is given in Eq. (6.6), which replaces the inequality sign in Eq. (6.5) with an equal to sign, then rearranged to give

$$\frac{\sigma_1 - \sigma_2}{S_y} = \frac{1}{n} \quad (6.6)$$

An alternate expression commonly used in place of Eq. (6.6) for the factor-of-safety (n) for the maximum-shear-stress theory can be defined using the maximum shear stress (τ_{\max}) and the yield strength in shear (S_{sy}) from Eq. (6.4) as

$$\frac{\tau_{\max}}{S_{sy}} = \frac{1}{n} \quad (6.7)$$

Distortion-Energy Theory. Without presenting the many steps in its development that can be found in any number of references, the expression given in Eq. (6.8) represents the combinations of the principal stresses (σ_1, σ_2) for a safe design according to the distortion-energy theory.

$$\sigma_1^2 + \sigma_2^2 - \sigma_1\sigma_2 < S_y^2 \quad (6.8)$$

The expression in Eq. (6.8) represents the equation of an ellipse inclined at 45° as shown in Fig. 6.4. Surprisingly, this ellipse passes through the six corners of the enclosed shape

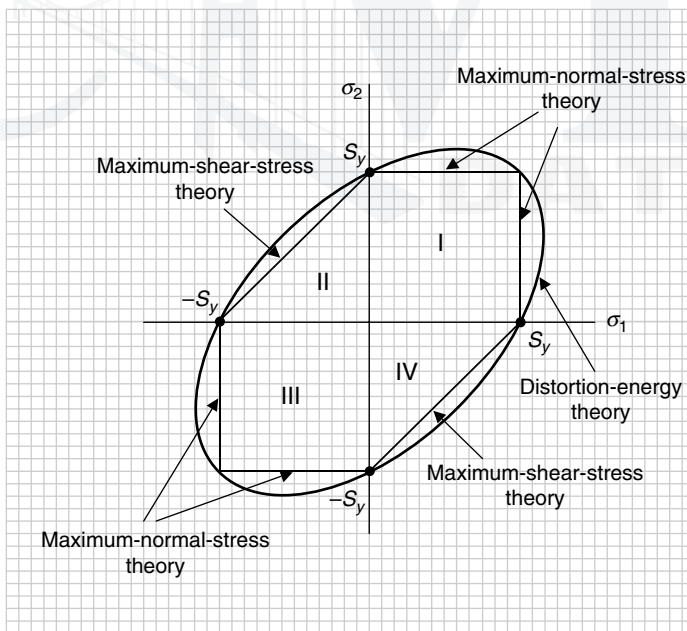

FIGURE 6.4 Distortion-energy theory (ductile).

shown in Fig. 6.3, which is a combination of the maximum-normal-stress theory in quadrants (I) and (III) and the maximum-shear-stress theory in quadrants (II) and (IV).

The factor-of-safety (n) for this theory is given in Eq. (6.9), which replaces the inequality sign in Eq. (6.8) with an equal to sign and is then rearranged to give

$$\frac{(\sigma_1^2 + \sigma_2^2 - \sigma_1\sigma_2)^{1/2}}{S_y} = \frac{1}{n} \quad (6.9)$$

Comparison to Experimental Data. These three theories would not be very useful in determining whether a design under static conditions is safe if they did not fit closely with the available experimental data. In Fig. 6.5, the available experimental data for known machine element failures under static conditions is shown by + symbols (see J. Marin, 1952).

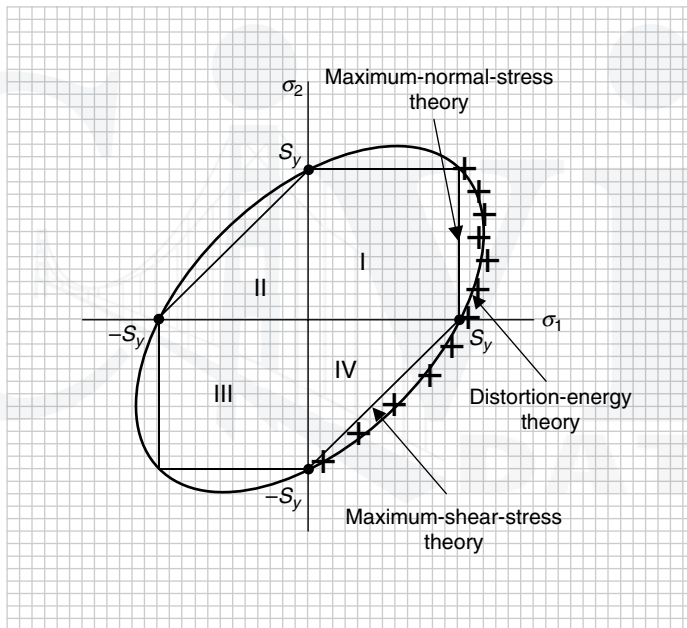

FIGURE 6.5 Comparison with experimental data (ductile).

Note that there is no experimental data in the second (II) and third (III) quadrants. This is not unexpected as combinations in the second (II) quadrant are impossible if the maximum principal stress (σ_1) is greater than or at least equal to the minimum principal stress (σ_2). Also, combinations in the third (III) quadrant require that the principal stress (σ_2) be at least equally or more negative than the principal stress (σ_1).

Recommendations for Ductile Materials. Based on the closeness of the fit of the experimental data shown in Fig. 6.5, the following are the recommendations as to which theory

best predicts whether a design is safe or not, specifically in the first (I) and fourth (IV) quadrants.

First (I): Distortion-energy theory is the most accurate. Maximum-normal-stress theory is okay, but conservative. Maximum-shear-stress theory does not apply.

Fourth (IV): Distortion-energy theory is the most accurate. Maximum-shear-stress theory is okay, but conservative. Maximum-normal-stress theory does not apply.

Graphically, these recommendations are shown in Fig. 6.6.

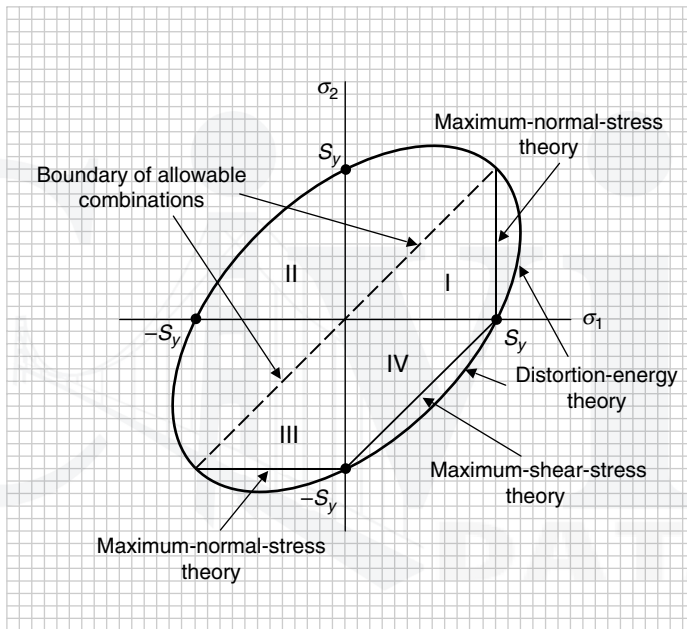

FIGURE 6.6 Summary of recommendations (ductile).

The line at 45° passing through the origin of the coordinate system in Fig. 6.6 establishes the left boundary of the possible combinations of the principal stresses (σ_1, σ_2). The vertical line in the first (I) quadrant represents the maximum-normal-stress theory, the line at 45° in the fourth (IV) quadrant represents the maximum-shear-stress theory, and the ellipse in both the first (I) and fourth (IV) quadrants represents the distortion-energy theory. Notice that the ellipse passes through the three corner points (S_y, S_y) , $(S_y, 0)$, and $(0, -S_y)$. Observe that the distortion-energy theory is the more accurate predictor for both quadrants, and is less conservative than the other two theories.

To conclude the discussion for ductile materials, Fig. 6.7 shows the load lines for uniaxial, biaxial, and pure shear combinations of the principal stresses (σ_1, σ_2).

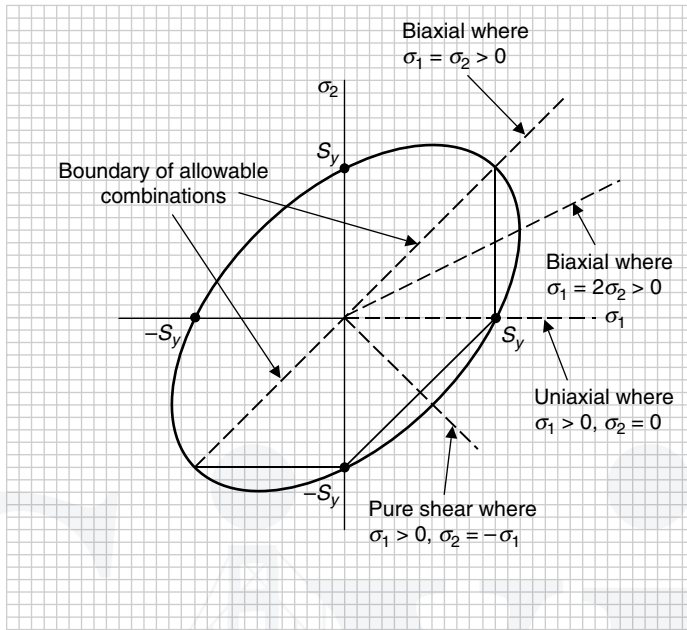

FIGURE 6.7 Load lines for uniaxial, biaxial, and pure shear combinations.

Consider the following example in both the U.S. Customary and SI/metric systems.

U.S. Customary

Example 1. Plot the combinations given in the table below of the principal stresses (σ_1, σ_2) from several selected examples presented earlier in Chap. 5, on a static design coordinate system for ductile materials. Show the boundaries of the recommended theories for determining if the combinations are safe, along with the four special load lines shown in Fig. 6.7. Also, determine the factor-of-safety for each combination. Use a yield strength (S_y) of 12 kpsi that is at the low end for magnesium alloys.

Summary of the principal stresses from selected examples (in kpsi)

Example	Principal stress (σ_1)	Principal stress (σ_2)
5 (§5.2)	11	-4
2 (§5.3)	12	0
3 (§5.3)	16	8
4 (§5.3)	10	-10

solution

Step 1. Plot the combinations of principal stresses from the given table.

This is shown in Fig. 6.8. Notice that the combination of principal stresses for Example 5 (Sec. 5.2) falls *outside* the boundary in the fourth (IV) quadrant, the combination for Example 2 (Sec. 5.3) falls on the uniaxial load line directly *on* the boundary, the combination

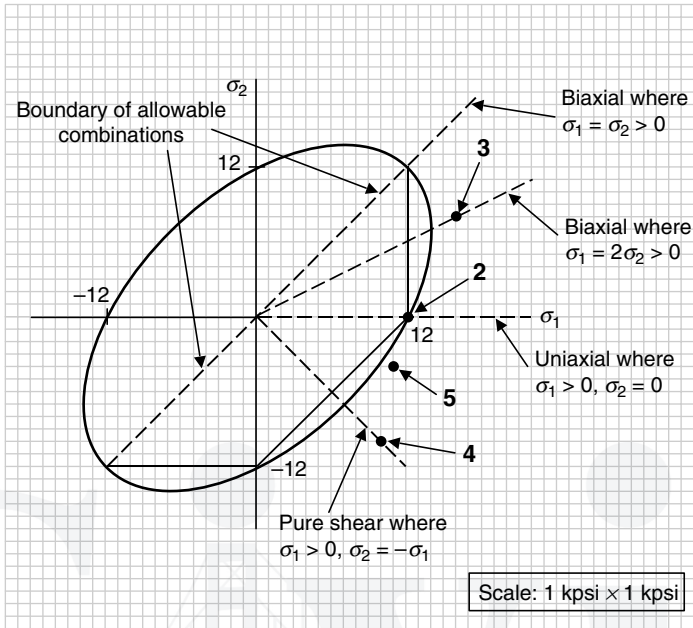

FIGURE 6.8 Principal stress combinations in Example 1 (U.S. Customary).

for Example 3 (Sec. 5.3) falls on the $(\sigma_1 = 2\sigma_2 > 0)$ biaxial load line *outside* the boundary, and the combination for Example 3 (Sec. 5.3) falls on the pure shear load line *outside* the boundary.

Step 2. Identify which theory is appropriate for each combination.

For all the examples the distortion-energy theory gives the most accurate information. However, for Example 5 (Sec. 5.2) and Example 4 (Sec. 5.3) the maximum-shear-stress theory would be okay, but would be more conservative. For Example 3 (Sec. 5.3), the maximum-normal-stress theory would be okay, but would be more conservative. For Example 2 (Sec. 5.3), all three theories are appropriate as they intersect at a point on the (σ_1) axis.

Step 3. Calculate the factor-of-safety for each combination, using the appropriate static design theory.

As stated in step 2, the distortion-energy theory gives the most accurate information, so use Eq. (6.9) to make the following calculations for each combination.

Example 5 (Sec. 5.2):

$$\frac{(\sigma_1^2 + \sigma_2^2 - \sigma_1\sigma_2)^{1/2}}{S_y} = \frac{1}{n} = \frac{((11)^2 + (-4)^2 - (11)(-4))^{1/2}}{12}$$

$$\frac{1}{n} = \frac{(121 + 16 + 44)^{1/2}}{12} = \frac{(181)^{1/2}}{12} = \frac{13.45}{12} = 1.12$$

$$n = \frac{1}{1.12} = 0.89 \text{ (unsafe)}$$

Example 2 (Sec. 5.3):

$$\frac{(\sigma_1^2 + \sigma_2^2 - \sigma_1\sigma_2)^{1/2}}{S_y} = \frac{1}{n} = \frac{((12)^2 + (0)^2 - (12)(0))^{1/2}}{12}$$

$$\frac{1}{n} = \frac{(144 + 0 + 0)^{1/2}}{12} = \frac{(144)^{1/2}}{12} = \frac{12}{12} = 1.0$$

$$n = \frac{1}{1.0} = 1.0 \text{ (okay, but marginal)}$$

Example 3 (Sec. 5.3):

$$\frac{(\sigma_1^2 + \sigma_2^2 - \sigma_1\sigma_2)^{1/2}}{S_y} = \frac{1}{n} = \frac{((16)^2 + (8)^2 - (16)(8))^{1/2}}{12}$$

$$\frac{1}{n} = \frac{(256 + 64 - 128)^{1/2}}{12} = \frac{(192)^{1/2}}{12} = \frac{13.86}{12} = 1.15$$

$$n = \frac{1}{1.15} = 0.87 \text{ (unsafe)}$$

Example 4 (Sec. 5.3):

$$\frac{(\sigma_1^2 + \sigma_2^2 - \sigma_1\sigma_2)^{1/2}}{S_y} = \frac{1}{n} = \frac{((10)^2 + (-10)^2 - (10)(-10))^{1/2}}{12}$$

$$\frac{1}{n} = \frac{(100 + 100 + 100)^{1/2}}{12} = \frac{(300)^{1/2}}{12} = \frac{17.32}{12} = 1.44$$

$$n = \frac{1}{1.44} = 0.69 \text{ (unsafe)}$$

Step 4. Compare the factors-of-safety found in step 3 with the maximum-normal-stress theory for Example 3 (Sec. 5.3) and the maximum-shear-stress theory for Examples 5 (Sec. 5.2) and 4 (Sec. 5.3).

As stated earlier, the combination for Example 2 (Sec. 5.3) falls directly on the boundary and where all three theories coincide. As both the principal stresses in Example 3 (Sec. 5.3) are positive, use the first expression in Eq. (6.2) to give

Example 3 (Sec. 5.3):

$$\frac{\sigma_1}{S_y} = \frac{1}{n} = \frac{16}{12} = 1.33$$

$$n = \frac{1}{1.33} = 0.75 \text{ (unsafe)}$$

where the factor-of-safety is smaller than obtained with the distortion-energy theory.

For Examples 5 (Sec. 5.2) and 4 (Sec. 5.3), use the expression in Eq. (6.6) to give

Example 5 (Sec. 5.2):

$$\frac{\sigma_1 - \sigma_2}{S_y} = \frac{1}{n} = \frac{11 - (-4)}{12} = \frac{15}{12} = 1.25$$

$$n = \frac{1}{1.25} = 0.80 \text{ (unsafe)}$$

Example 4 (Sec. 5.3):

$$\frac{\sigma_1 - \sigma_2}{S_y} = \frac{1}{n} = \frac{10 - (-10)}{12} = \frac{20}{12} = 1.67$$

$$n = \frac{1}{1.67} = 0.60 \text{ (unsafe)}$$

where again the factors-of-safety are smaller than obtained with the distortion-energy theory. This is what is meant by being more conservative, or more restrictive.

SI/Metric

Example 1. Plot the combinations given in the table below of the principal stresses (σ_1, σ_2) from several selected examples presented earlier in Chap. 5, on a static design coordinate system for ductile materials. Show the boundaries of the recommended theories for determining if the combinations are safe, along with the four special load lines shown in Fig. 6.7. Also, determine the factor-of-safety for each combination. Use a yield strength (S_y) of 84 MPa that is at the low end for magnesium alloys.

Summary of the principal stresses from selected examples (in MPa)

Example	Principal stress (σ_1)	Principal stress (σ_2)
5 (§5.2)	83	-33
2 (§5.3)	84	0
3 (§5.3)	112	56
4 (§5.3)	70	-70

solution

Step 1. Plot the combinations of principal stresses from the given table.

This is shown in Fig. 6.9. Notice that the combination of principal stresses for Example 5 (Sec. 5.2) falls *outside* the boundary in the fourth (IV) quadrant, the combination for Example 2 (Sec. 5.3) falls on the uniaxial load line directly *on* the boundary, the combination for Example 3 (Sec. 5.3) falls on the ($\sigma_1 = 2\sigma_2 > 0$) biaxial load line *outside* the boundary, and the combination for Example 4 (Sec. 5.3) falls on the pure shear load line *outside* the boundary.

Step 2. Identify which theory is appropriate for each combination.

For all the examples the distortion-energy theory gives the most accurate information. However, for Examples 5 and 4 the maximum-shear-stress theory would be okay, but would be more conservative. For Example 3, the maximum-normal-stress theory would be okay, but would be more conservative. For Example 2, all three theories are appropriate as they intersect at a point on the (σ_1) axis.

Step 3. Calculate the factor-of-safety for each combination, using the appropriate static design theory.

As stated in step 2, the distortion-energy theory gives the most accurate information, so use Eq. (6.9) to make the following calculations for each combination.

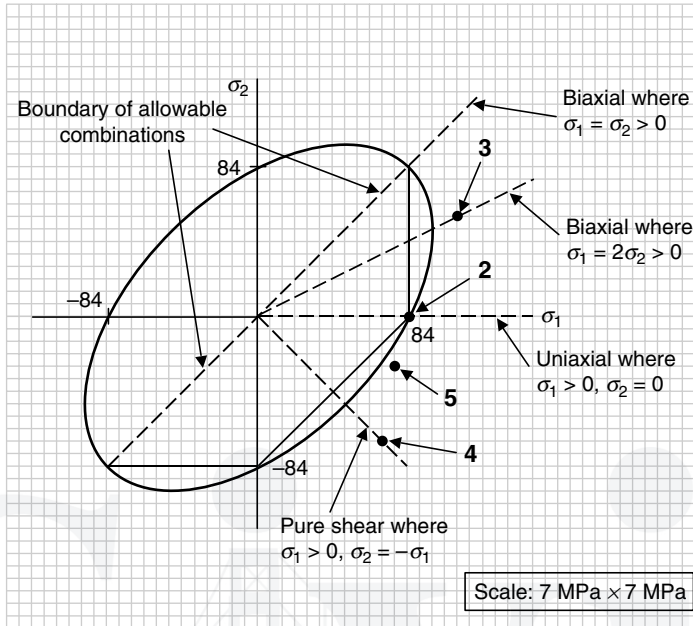

FIGURE 6.9 Principal stress combinations in Example 1 (SI/metric).

Example 5 (Sec. 5.2):

$$\frac{(\sigma_1^2 + \sigma_2^2 - \sigma_1\sigma_2)^{1/2}}{S_y} = \frac{1}{n} = \frac{((83)^2 + (-33)^2 - (83)(-33))^{1/2}}{84}$$

$$\frac{1}{n} = \frac{(6,889 + 1,089 + 2,739)^{1/2}}{84} = \frac{(10,717)^{1/2}}{84} = \frac{103.52}{84} = 1.23$$

$$n = \frac{1}{1.23} = 0.81 \text{ (unsafe)}$$

Example 2 (Sec. 5.3):

$$\frac{(\sigma_1^2 + \sigma_2^2 - \sigma_1\sigma_2)^{1/2}}{S_y} = \frac{1}{n} = \frac{((84)^2 + (0)^2 - (84)(0))^{1/2}}{84}$$

$$\frac{1}{n} = \frac{(7,056 + 0 + 0)^{1/2}}{84} = \frac{(7,056)^{1/2}}{84} = \frac{84}{84} = 1.0$$

$$n = \frac{1}{1.0} = 1.0 \text{ (okay, but marginal)}$$

Example 3 (Sec. 5.3):

$$\frac{(\sigma_1^2 + \sigma_2^2 - \sigma_1\sigma_2)^{1/2}}{S_y} = \frac{1}{n} = \frac{((112)^2 + (56)^2 - (112)(56))^{1/2}}{84}$$

$$\frac{1}{n} = \frac{(12,544 + 3,136 - 6,272)^{1/2}}{84} = \frac{(9,408)^{1/2}}{84} = \frac{96.99}{84} = 1.15$$

$$n = \frac{1}{1.15} = 0.87 \text{ (unsafe)}$$

Example 4 (Sec. 5.3):

$$\frac{(\sigma_1^2 + \sigma_2^2 - \sigma_1\sigma_2)^{1/2}}{S_y} = \frac{1}{n} = \frac{((70)^2 + (-70)^2 - (70)(-70))^{1/2}}{84}$$

$$\frac{1}{n} = \frac{(4,900 + 4,900 + 4,900)^{1/2}}{84} = \frac{(14,700)^{1/2}}{84} = \frac{121.24}{84} = 1.44$$

$$n = \frac{1}{1.44} = 0.69 \text{ (unsafe)}$$

Step 4. Compare the factors-of-safety found in step 3 with the maximum-normal-stress theory for Example 3 and the maximum-shear-stress theory for Examples 5 and 4.

As stated earlier, the combination for Example 2 falls directly on the boundary and where all three theories coincide. As both of the principal stresses in Example 3 are positive, use the first expression in Eq. (6.2) to give

Example 3 (Sec. 5.3):

$$\frac{\sigma_1}{S_y} = \frac{1}{n} = \frac{112}{84} = 1.33$$

$$n = \frac{1}{1.33} = 0.75 \text{ (unsafe)}$$

where the factor-of-safety is smaller than obtained with the distortion-energy theory.

For Examples 5 and 4, use the expression in Eq. (6.6) to give

Example 5 (Sec. 5.2):

$$\frac{\sigma_1 - \sigma_2}{S_y} = \frac{1}{n} = \frac{83 - (-33)}{84} = \frac{116}{84} = 1.38$$

$$n = \frac{1}{1.38} = 0.72 \text{ (unsafe)}$$

Example 4 (Sec. 5.3):

$$\frac{\sigma_1 - \sigma_2}{S_y} = \frac{1}{n} = \frac{70 - (-70)}{84} = \frac{140}{84} = 1.67$$

$$n = \frac{1}{1.67} = 0.60 \text{ (unsafe)}$$

where again the factors-of-safety are smaller than that obtained with the distortion-energy theory. This is what is meant by being more conservative, or more restrictive.

The fact that three of the four combinations in Example 1 resulted in unsafe designs, and the fourth was literally borderline, indicates that a stronger material should be used for these machine elements. For example, the yield stress (S_y) could be doubled by choosing cast iron, or tripled by choosing a structural steel like ASTM-A36.

Comparison of Maximum-Shear-Stress Theory and Distortion-Energy Theory. In Eq. (6.4), repeated here, the maximum shear stress (τ_{\max}) associated with the maximum-shear-stress theory was found to be related to the yield stress (S_y) as

$$\tau_{\max} = \frac{\sigma_1 - \sigma_2}{2} = \frac{S_y - 0}{2} = \frac{S_y}{2} = S_{sy} \quad (6.4)$$

or in decimal form

$$\tau_{\max} = 0.5 S_y \quad (6.10)$$

For special cases of torsion, which is a pure shear condition where the maximum principal stress (σ_1) is the shear stress (τ) and the minimum principal stress (σ_2) is the negative of the shear stress ($-\tau$), the distortion-energy theory from Eq. (6.8), repeated here, gives

$$\sigma_1^2 + \sigma_2^2 - \sigma_1\sigma_2 = S_y^2 \quad (6.8)$$

where the inequality sign has been replaced by an equal to sign. Substituting the shear stress (τ), which would actually be the maximum shear stress (τ_{\max}), and ($-\tau$) gives

$$\begin{aligned} (\tau)^2 + (-\tau)^2 - (\tau)(-\tau) &= \tau^2 + \tau^2 + \tau^2 = 3\tau^2 = S_y^2 \\ \tau^2 &= \frac{S_y^2}{3} \\ \tau &= \frac{S_y}{\sqrt{3}} = 0.577 S_y \end{aligned} \quad (6.11)$$

Summarizing Eqs. (6.10) and (6.11) gives

$$\tau_{\max} = \begin{cases} 0.5 S_y & \text{maximum-shear-stress theory} \\ 0.577 S_y & \text{distortion-energy theory} \end{cases} \quad (6.12)$$

It is common to see the distortion-energy theory rounded to ($0.60 S_y$) instead of the three decimal place result given in Eq. (6.12).

6.1.2 Static Design for Brittle Materials

In contrast to ductile materials, brittle materials exhibit a true strain at fracture of less than 5 percent. Failure of a machine element made of a brittle material is usually associated with the element suddenly fracturing. Therefore, the important strength for determining if the design of the machine element under static conditions is safe, is the ultimate strength (S_u). As mentioned earlier, brittle materials have an ultimate strength in compression, designated (S_{uc}), significantly greater than its ultimate strength in tension, designated (S_{ut}). (In Figs. 6.10 through 6.17 that follow, $S_{uc} = 3S_{ut}$.)

For brittle materials, there are three static design theories that fit the available experimental data on whether the combinations of (σ_1, σ_2) for a machine element are safe:

- Maximum-normal-stress theory
- Coulomb-Mohr theory
- Modified Coulomb-Mohr theory

Each of these three theories will be discussed separately, followed by the appropriate recommendations as to which theory is best for every possible combination of the principal stresses (σ_1, σ_2) . Remember, combinations in the second (II) quadrant are impossible if it is assumed that the maximum principal stress (σ_1) is always greater than or at least equal to the minimum principal stress (σ_2) , even though the mathematical expressions and graphical representations that will be shown allow this combination.

Maximum-Normal-Stress Theory. The square in Fig. 6.10 represented by the respective values of the tensile and compressive strengths shown in Fig. 6.1 is the graphical representation of the maximum-normal-stress theory of static failure. Any combination of the principal stresses (σ_1) and (σ_2) that are inside the square is a safe design and any combination outside the square is unsafe. Remember, the strengths (S_{ut}) and (S_{uc}) are positive values.

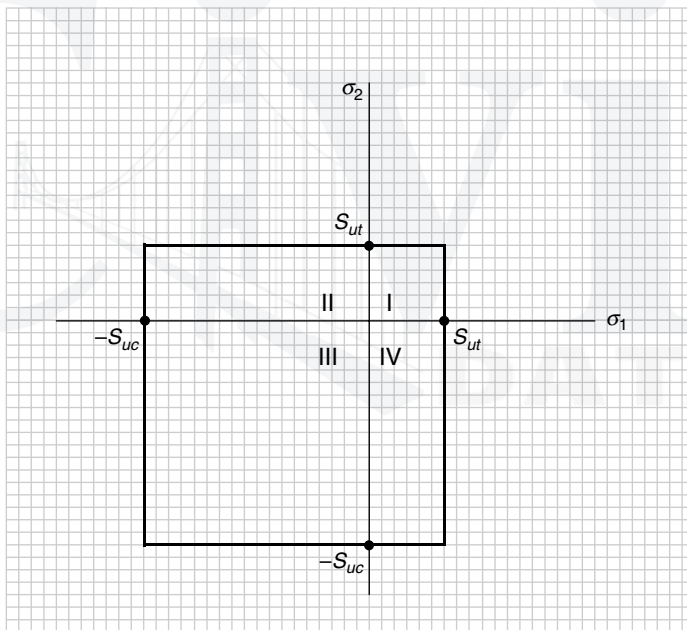

FIGURE 6.10 Maximum-normal-stress theory (brittle).

The mathematical expressions representing a safe design according to the maximum-normal-stress theory are given in Eq. (6.13),

$$\sigma_1 < S_{ut} \quad \text{or} \quad \sigma_2 > -S_{uc} \quad (6.13)$$

where the first expression in Eq. (6.13) results in a boundary at the vertical line, $(\sigma_1 = S_{ut})$, and the second expression results in a boundary at the horizontal line at, $(\sigma_2 = -S_{uc})$.

The boundaries at the vertical line, ($\sigma_1 = -S_{uc}$), and the horizontal line, ($\sigma_2 = S_{ut}$), are permissible by mathematics but are not allowable combinations of (σ_1, σ_2).

The factor-of-safety (n) for this theory is given in Eq. (6.14), which replaces the inequality signs in Eq. (6.13) with equal to signs and are then rearranged to give

$$\frac{\sigma_1}{S_{ut}} = \frac{1}{n} \quad \text{or} \quad \frac{\sigma_2}{-S_{uc}} = \frac{1}{n} \quad (6.14)$$

The factor-of-safety (n) in either expression of Eq. (6.14) represents how close the combination of the principal stresses (σ_1, σ_2) is to the boundary defined by the theory. A factor-of-safety much greater than 1 means the (σ_1, σ_2) combination is not only inside the boundary of the theory but far from it. A factor-of-safety equal to (1) means the combination is on the boundary. Any factor-of-safety less than 1 is outside the boundary and represents an unsafe static loading condition.

Coulomb-Mohr Theory. The lines connecting the ultimate strength in tension (S_{ut}) with the ultimate strength in compression ($-S_{uc}$), one in the second (II) quadrant and one in the fourth (IV) quadrant, as shown in Fig. 6.11, represent graphically the Coulomb-Mohr theory of static failure. To provide a closed boundary, the vertical and horizontal lines of the maximum-normal-stress theory in the first (I) and third (III) quadrants are used with the Coulomb-Mohr theory. Any combination of the principal stresses (σ_1) and (σ_2) that are inside this enclosed area is a safe design and any combination outside this area is unsafe.

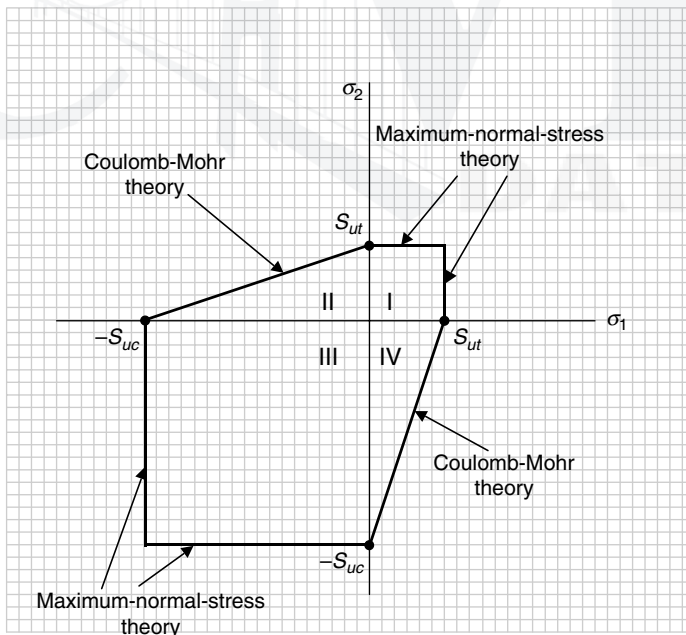

FIGURE 6.11 Coulomb-Mohr theory (brittle).

The mathematical expressions representing a safe design according to the Coulomb-Mohr theory are given in Eq. (6.15),

$$\frac{\sigma_1}{S_{ut}} - \frac{\sigma_2}{S_{uc}} < 1 \quad \text{or} \quad \frac{\sigma_2}{S_{ut}} - \frac{\sigma_1}{S_{uc}} < 1 \quad (6.15)$$

where the first expression in Eq. (6.15) specifies the line in the fourth (IV) quadrant and the second expression specifies the line, only mathematically, in the second (II) quadrant.

The factor-of-safety (n) for this theory is given in Eq. (6.16), which replaces the inequality signs in Eq. (6.15) with equal to signs to give

$$\frac{\sigma_1}{S_{ut}} - \frac{\sigma_2}{S_{uc}} = \frac{1}{n} \quad \text{or} \quad \frac{\sigma_2}{S_{ut}} - \frac{\sigma_1}{S_{uc}} = \frac{1}{n} \quad (6.16)$$

Modified Coulomb-Mohr Theory. The maximum-normal-stress theory can be expanded into the fourth (IV) quadrant if the vertical line at ($\sigma_1 = S_{ut}$) in the first (I) quadrant is extended downward until it reaches the point ($S_{ut}, -S_{ut}$). If a line is then drawn that connects the point ($0, -S_{uc}$) with the point ($S_{ut}, -S_{ut}$), then this new line represents the modified Coulomb-Mohr theory. These two new lines are shown dashed in Fig. 6.12. Although allowed mathematically, there are two lines in the second (II) quadrant, one connecting the points ($0, S_{ut}$) and ($-S_{ut}, S_{ut}$) representing an extension of the maximum-normal-stress theory and the other connecting the points ($-S_{ut}, S_{ut}$) and ($-S_{uc}, 0$) representing the modified Coulomb-Mohr theory, but as stated many times already, no combinations of (σ_1, σ_2) are possible in the second (II) quadrant if the principal stress (σ_1) is always noted as the greater of the two principal stresses.

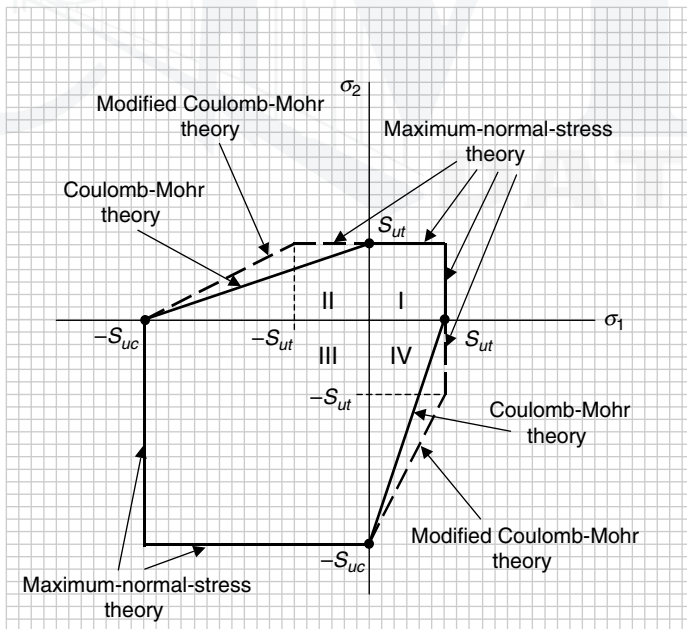

FIGURE 6.12 Modified Coulomb-Mohr theory (brittle).

The mathematical expressions representing a safe design according to the modified Coulomb-Mohr theory are given in Eq. (6.17),

$$\frac{\sigma_1}{S_{ut}} \left(1 - \frac{S_{ut}}{S_{uc}} \right) - \frac{\sigma_2}{S_{uc}} < 1 \quad \text{or} \quad \frac{\sigma_2}{S_{ut}} \left(1 - \frac{S_{ut}}{S_{uc}} \right) - \frac{\sigma_1}{S_{uc}} < 1 \quad (6.17)$$

where the first expression in Eq. (6.17) specifies the line in the fourth (IV) quadrant connecting the points $(0, -S_{uc})$ and $(S_{ut}, -S_{ut})$, and the second expression specifies the line in the second (II) quadrant connecting the points $(-S_{uc}, 0)$ and $(-S_{ut}, S_{ut})$.

The factor-of-safety (n) for this theory is given in Eq. (6.18), which replaces the inequality signs in Eq. (6.17) with equal to signs to give

$$\frac{\sigma_1}{S_{ut}} \left(1 - \frac{S_{ut}}{S_{uc}} \right) - \frac{\sigma_2}{S_{uc}} = \frac{1}{n} \quad \text{or} \quad \frac{\sigma_2}{S_{ut}} \left(1 - \frac{S_{ut}}{S_{uc}} \right) - \frac{\sigma_1}{S_{uc}} = \frac{1}{n} \quad (6.18)$$

Comparison to Experimental Data. As was said about the theories associated with ductile materials, these three theories would not be very useful in determining whether a design under static conditions is safe if they did not fit closely with the available experimental data. In Fig. 6.13, the available experimental data for known machine element failures under static conditions is shown by + symbols (see C. Walton, 1971).

Note that the data shown are primarily in the first (I) and fourth (IV) quadrants; none in the second (II) and third (III) quadrants. This is not unexpected as combinations in the second (II) quadrant are impossible if the principal stress (σ_1) is noted as the greater of the two principal stresses. Also, combinations in the third (III) quadrant require that the principal stress (σ_2) be at least equally or more negative than the principal stress (σ_1).

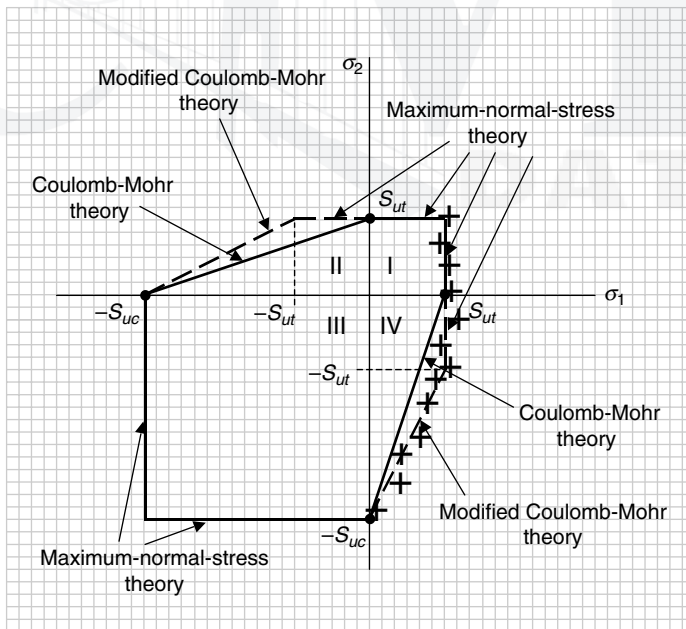

FIGURE 6.13 Comparison with experimental data (brittle).

Remember that for brittle materials, the ultimate strength in compression is significantly greater than the ultimate strength in tension.

Recommendations for Brittle Materials. Based on the closeness of the fit of the experimental data shown in Fig. 6.13, the following are the recommendations as to which theory best predicts whether a design is safe or not, specifically in the first (I) and fourth (IV) quadrants.

First (I): ($\sigma_1 > 0$ and $\sigma_2 > 0$)

Maximum-normal-stress theory is the most accurate. Coulomb-Mohr theory does not apply. Modified Coulomb-Mohr theory does not apply.

Fourth (IV): ($\sigma_1 > 0$ and $0 > \sigma_2 > -S_{ut}$)

Maximum-normal-stress theory is the most accurate. Coulomb-Mohr theory is okay, but conservative. Modified Coulomb-Mohr theory does not apply.

Fourth (IV): ($\sigma_1 > 0$ and $-S_{ut} > \sigma_2 > -S_{uc}$)

Modified Coulomb-Mohr theory is the most accurate. Coulomb-Mohr theory is okay, but conservative. Maximum-normal-stress theory does not apply.

Graphically, these recommendations are shown in Fig. 6.14.

The line at 45° passing through the origin of the coordinate system in Fig. 6.14 establishes the left boundary of the possible combinations of the principal stresses (σ_1, σ_2). The vertical line in the first (I) quadrant that extends downward to $(-S_{ut})$ in the fourth (IV) quadrant, and

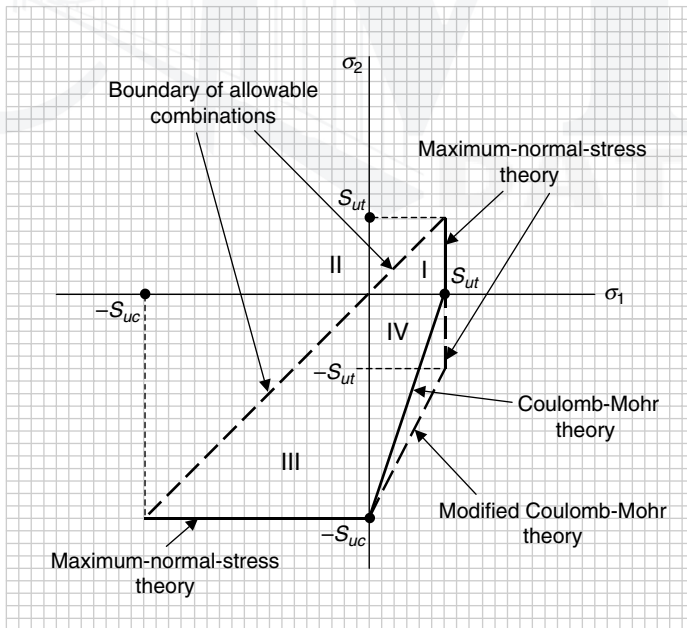

FIGURE 6.14 Summary of recommendations (brittle).

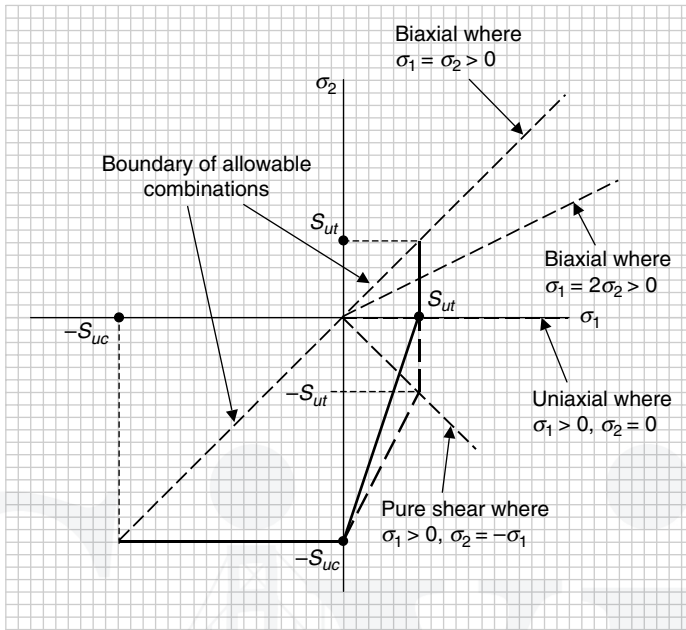

FIGURE 6.15 Load lines for uniaxial, biaxial, and pure shear combinations.

the horizontal line in the third (III) quadrant, represents the maximum-normal-stress theory. The solid line that connects the point $(0, -S_{uc})$ to the point $(S_{ut}, 0)$ represents the Coulomb-Mohr theory. The dotted line from point $(0, -S_{uc})$ to the point $(S_{ut}, -S_{ut})$ represents the modified Coulomb-Mohr theory.

To conclude the discussion for brittle materials, Fig. 6.15 shows the load lines for uniaxial, biaxial, and pure shear combinations of the principal stresses (σ_1, σ_2) .

Consider the following example in both the U.S. Customary and SI/metric systems.

U.S. Customary

Example 2. Plot the combinations given in the table below of the principal stresses (σ_1, σ_2) on a static design coordinate system for brittle materials. Show the boundaries of the recommended theories for determining if the combinations are safe, along with the four special load lines shown in Fig. 6.15. Also, determine the factor-of-safety for each combination. Use an ultimate strength in tension (S_{ut}) of 30 kpsi and an ultimate strength in compression (S_{uc}) of 90 kpsi that are the typical values for cast iron.

Principal stresses (in kpsi)		
Point	Principal stress (σ_1)	Principal stress (σ_2)
1	40	-15
2	30	0
3	20	20
4	25	-25
5	15	-55

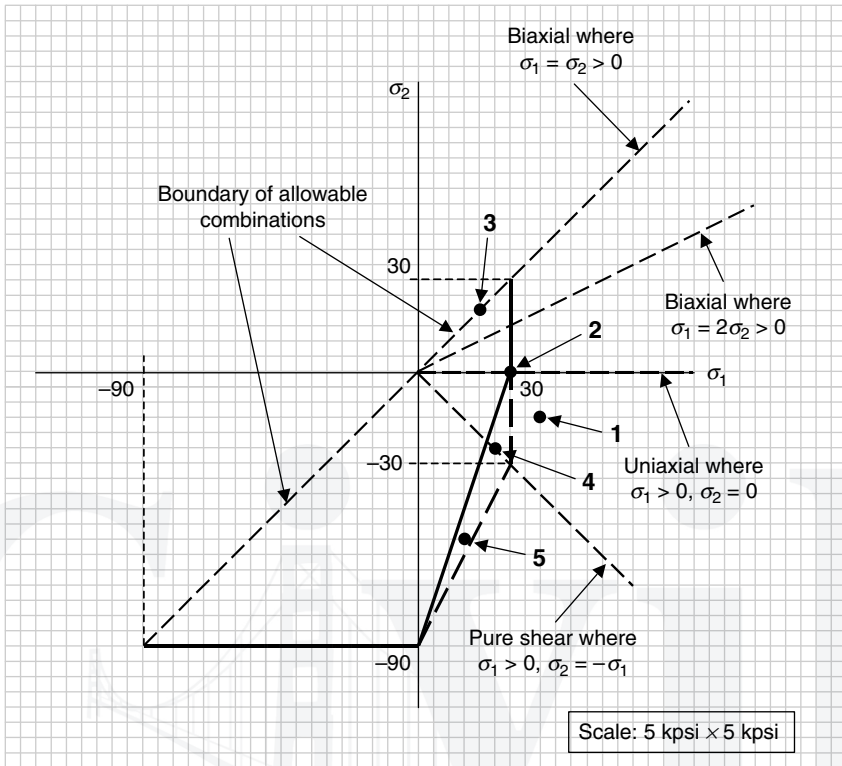

FIGURE 6.16 Principal stress combinations in Example 2 (U.S. Customary).

solution

Step 1. Plot the combinations of principal stresses from the given table.

This is shown in Fig. 6.16. Notice that the combination of principal stresses for point 1 falls *outside* the boundary in the fourth (IV) quadrant, the combination for point 2 falls on the uniaxial load line directly *on* the boundary, the combination for point 3 falls on the ($\sigma_1 = \sigma_2 > 0$) biaxial load line *inside* the boundary, the combination for point 4 falls on the pure shear load line *outside* the boundary defined by the Coulomb-Mohr theory, but *inside* the boundary defined by the maximum-normal-stress theory, and the combination for point 5 falls *outside* the boundary defined by the Coulomb-Mohr theory, but *inside* the boundary defined by the modified Coulomb-Mohr theory.

Step 2. Identify which theory is appropriate for each combination.

For points 1, 2, 3, and 4, the maximum-normal-stress theory gives the most accurate information, and for point 5 the modified Coulomb-Mohr theory gives the most accurate information. However, for points 4 and 5 the Coulomb-Mohr theory would be okay, but would be more conservative. For point 2, either the maximum-normal-stress theory or the Coulomb-Mohr theory are appropriate as they intersect at a point on the (σ_1) axis.

Step 3. Calculate the factor-of-safety for each combination, using the appropriate static design theory.

As stated in step 2, the maximum-normal-stress theory gives the most accurate information for points 1, 2, 3, and 4, so use Eq. (6.14) to make the following calculations for these combinations.

Point 1:

$$\frac{\sigma_1}{S_{ut}} = \frac{1}{n} = \frac{40}{30} = 1.33$$

$$n = \frac{1}{1.33} = 0.75 \text{ (unsafe)}$$

Point 2:

$$\frac{\sigma_1}{S_{ut}} = \frac{1}{n} = \frac{30}{30} = 1.0$$

$$n = \frac{1}{1.0} = 1.0 \text{ (okay, but marginal)}$$

Point 3:

$$\frac{\sigma_1}{S_{ut}} = \frac{1}{n} = \frac{20}{30} = 0.67$$

$$n = \frac{1}{0.67} = 1.5 \text{ (safe)}$$

Point 4:

$$\frac{\sigma_1}{S_{ut}} = \frac{1}{n} = \frac{25}{30} = 0.83$$

$$n = \frac{1}{0.83} = 1.2 \text{ (safe)}$$

Also stated in step 2, the modified Coulomb-Mohr theory gives the most accurate information for point 5, so use the first expression in Eq. (6.18) to make the following calculation for this combination.

Point 5:

$$\frac{\sigma_1}{S_{ut}} \left(1 - \frac{S_{ut}}{S_{uc}} \right) - \frac{\sigma_2}{S_{uc}} = \frac{1}{n} = \frac{15}{30} \left(1 - \frac{30}{90} \right) - \frac{-55}{90}$$

$$\frac{1}{n} = \frac{15}{30} \left(1 - \frac{30}{90} \right) - \frac{-55}{90} = \frac{1}{2} \left(\frac{60}{90} \right) + \frac{55}{90} = \frac{30}{90} + \frac{55}{90} = \frac{85}{90} = 0.94$$

$$n = \frac{1}{0.94} = 1.06 \text{ (safe, but just barely)}$$

Step 4. Compare the factors-of-safety found in step 3 for Points 4 and 5 with the Coulomb-Mohr theory given in the first expression of Eq. (6.16).

Point 4:

$$\frac{\sigma_1}{S_{ut}} - \frac{\sigma_2}{S_{uc}} = \frac{1}{n} = \frac{25}{30} - \frac{-25}{90}$$

$$\frac{1}{n} = \frac{25}{30} - \frac{-25}{90} = \frac{25}{30} + \frac{25}{90} = \frac{75}{90} + \frac{25}{90} = \frac{100}{90} = 1.11$$

$$n = \frac{1}{1.11} = 0.90 \text{ (unsafe)}$$

Point 5:

$$\frac{\sigma_1}{S_{ut}} - \frac{\sigma_2}{S_{uc}} = \frac{1}{n} = \frac{15}{30} - \frac{-55}{90}$$

$$\frac{1}{n} = \frac{15}{30} - \frac{-55}{90} = \frac{15}{30} + \frac{55}{90} = \frac{45}{90} + \frac{55}{90} = \frac{100}{90} = 1.11$$

$$n = \frac{1}{1.11} = 0.90 \text{ (unsafe)}$$

where the factors-of-safety found are less than one and indicates an unsafe static condition. This is why the Coulomb-Mohr theory is more conservative, or more restrictive, in this region of the diagram.

SI/Metric

Example 2. Plot the combinations given in the table below of the principal stresses (σ_1, σ_2) on a static design coordinate system for brittle materials. Show the boundaries of the recommended theories for determining if the combinations are safe, along with the four special load lines shown in Fig. 6.15. Also, determine the factor-of-safety for each combination. Use an ultimate strength in tension (S_{ut}) of 210 MPa and an ultimate strength in compression (S_{uc}) of 630 MPa that are typical values for cast iron.

Principal stresses (in MPa)

Point	Principal stress (σ_1)	Principal stress (σ_2)
1	280	-105
2	210	0
3	140	140
4	175	-175
5	105	-385

solution

Step 1. Plot the combinations of principal stresses from the given table.

This is shown in Fig. 6.17. Notice that the combination of principal stresses for point 1 falls *outside* the boundary in the fourth (IV) quadrant, the combination for point 2 falls on the uniaxial load line directly *on* the boundary, the combination for point 3 falls on the ($\sigma_1 = \sigma_2 > 0$) biaxial load line *inside* the boundary, the combination for point 4 falls on the pure shear load line *outside* the boundary defined by the Coulomb-Mohr theory, but *inside* the boundary defined by the maximum-normal-stress theory, and the combination for point 5 falls *outside* the boundary defined by the Coulomb-Mohr theory, but *inside* the boundary defined by the modified Coulomb-Mohr theory.

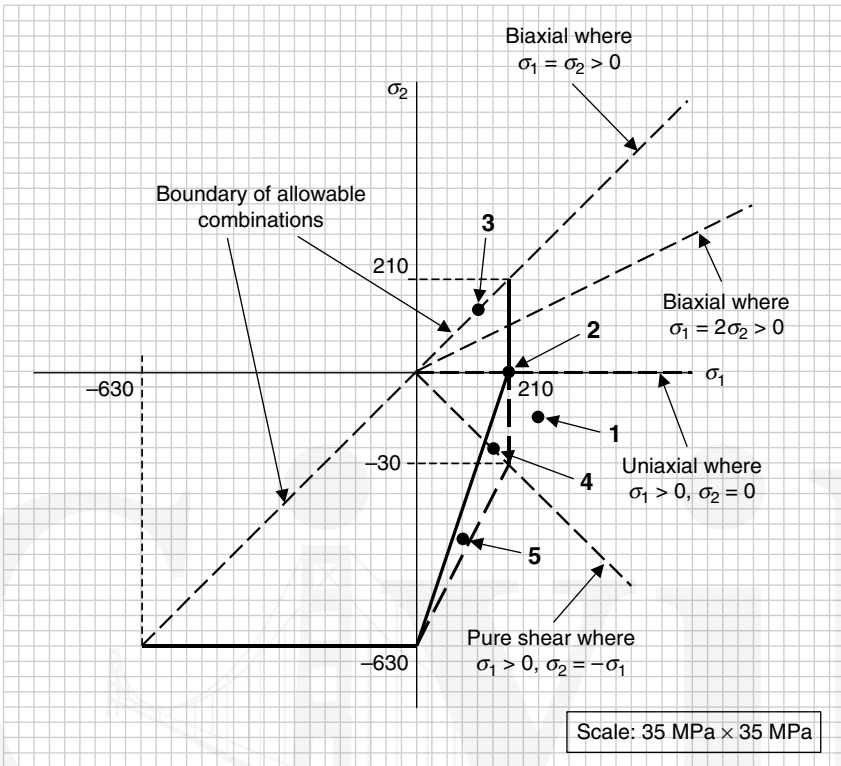

FIGURE 6.17 Principal stress combinations in Example 2 (SI/metric).

Step 2. Identify which theory is appropriate for each combination.

For points 1, 2, 3, and 4, the maximum-normal-stress theory gives the most accurate information, and for point 5 the modified Coulomb-Mohr theory gives the most accurate information. However, for points 4 and 5 the Coulomb-Mohr theory would be okay, but would be more conservative. For point 2, either the maximum-normal-stress theory or the Coulomb-Mohr theory are appropriate as they intersect at a point on the (σ_1) axis.

Step 3. Calculate the factor-of-safety for each combination, using the appropriate static design theory.

As stated in step 2, the maximum-normal-stress theory gives the most accurate information for points 1, 2, 3, and 4, so use Eq. (6.14) to make the following calculations for these combinations.

Point 1:

$$\frac{\sigma_1}{S_{ut}} = \frac{1}{n} = \frac{280}{210} = 1.33$$

$$n = \frac{1}{1.33} = 0.75 \text{ (unsafe)}$$

Point 2:

$$\frac{\sigma_1}{S_{ut}} = \frac{1}{n} = \frac{210}{210} = 1.0$$

$$n = \frac{1}{1.0} = 1.0 \text{ (okay, but marginal)}$$

Point 3:

$$\frac{\sigma_1}{S_{ut}} = \frac{1}{n} = \frac{140}{210} = 0.67$$

$$n = \frac{1}{0.67} = 1.5 \text{ (safe)}$$

Point 4:

$$\frac{\sigma_1}{S_{ut}} = \frac{1}{n} = \frac{175}{210} = 0.83$$

$$n = \frac{1}{0.83} = 1.2 \text{ (safe)}$$

Also stated in step 2, the modified Coulomb-Mohr theory gives the most accurate information for point 5, so use the first expression in Eq. (6.18) to make the following calculation for this combination.

Point 5:

$$\frac{\sigma_1}{S_{ut}} \left(1 - \frac{S_{ut}}{S_{uc}} \right) - \frac{\sigma_2}{S_{uc}} = \frac{1}{n} = \frac{105}{210} \left(1 - \frac{210}{630} \right) - \frac{-385}{630}$$

$$\frac{1}{n} = \frac{105}{210} \left(1 - \frac{210}{630} \right) - \frac{-385}{630} = \frac{1}{2} \left(\frac{420}{630} \right) + \frac{385}{630} = \frac{210}{630} + \frac{385}{630} = \frac{595}{630} = 0.94$$

$$n = \frac{1}{0.94} = 1.06 \text{ (safe, but just barely)}$$

Step 4. Compare the factors-of-safety found in step 3 for Points 4 and 5 with the Coulomb-Mohr theory given in the first expression of Eq. (6.16).

Point 4:

$$\frac{\sigma_1}{S_{ut}} - \frac{\sigma_2}{S_{uc}} = \frac{1}{n} = \frac{175}{210} - \frac{-175}{630}$$

$$\frac{1}{n} = \frac{175}{210} - \frac{-175}{630} = \frac{175}{210} + \frac{175}{630} = \frac{525}{630} + \frac{175}{630} = \frac{700}{630} = 1.11$$

$$n = \frac{1}{1.11} = 0.90 \text{ (unsafe)}$$

Point 5:

$$\frac{\sigma_1}{S_{ut}} - \frac{\sigma_2}{S_{uc}} = \frac{1}{n} = \frac{105}{210} - \frac{-385}{630}$$

$$\frac{1}{n} = \frac{105}{210} - \frac{-385}{630} = \frac{105}{210} + \frac{385}{630} = \frac{315}{630} + \frac{385}{630} = \frac{700}{630} = 1.11$$

$$n = \frac{1}{1.11} = 0.90 \text{ (unsafe)}$$

where the factors-of-safety found are less than 1 and indicates an unsafe static condition. This is why the Coulomb-Mohr theory is more conservative or more restrictive in this region of the diagram.

6.1.3 Stress-Concentration Factors

The normal (σ) and shear (τ) stress formulas presented in Chap. 1 for fundamental loadings and Chap. 3 for advanced loadings, and that were summarized in Tables 4.1 and 4.2 in Chap. 4 on combined loadings, were developed for machine elements having uniform geometric features. Adding such things as a hole or notches to a bar in tension or bending, or changing the diameter of a shaft in torsion or bending, produce what are called *stress concentrations* in the machine element at the change in geometry. Manufacturing processes can also create stress concentrations, such as shoulder fillets at the transition between two different diameters of a shaft. Even the welding process can produce significant stress concentrations.

As it turns out, stress concentrations are not a problem for machine elements made of ductile materials as the material will deform appropriately to adjust to these stress concentrations. However, machine elements made of brittle materials are very susceptible to stress concentrations, and therefore, stress-concentration factors should always be incorporated in the stress calculations.

As an example of a change in the geometry of a machine element, the rectangular bar with a transverse hole shown in Fig. 6.18 is loaded axially in tension by the two forces (P).

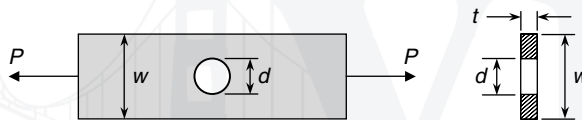

FIGURE 6.18 Bar with transverse hole in tension.

The cross-sectional area (A) for calculating the axial stress (σ_{axial}) is the width (w) times the thickness (t). The axial stress is therefore given by Eq. (6.19) as

$$\sigma_{\text{axial}} = \frac{P}{A} = \frac{P}{wt} \quad (6.19)$$

However, the cross-sectional area of the bar at the hole (A_o) is smaller than the area (A) and equal to the width ($w - d$) times the thickness (t), which means the stress in the bar at the hole (σ_o) is greater than the axial stress (σ_{axial}) and given by Eq. (6.20).

$$\sigma_o = \frac{P}{A_o} = \frac{P}{(w - d)(t)} \quad (6.20)$$

In addition to a reduced area, the axial stress at the hole (σ_o) must be multiplied by a stress-concentration factor (K_t) to provide the design normal stress (σ_{xx}) from which principal stresses (σ_1) and (σ_2) and the maximum shear stress (τ_{max}) can be determined. The design normal stress (σ_{xx}) is given in Eq. (6.21) as

$$\sigma_{xx} = K_t \sigma_o \quad (6.21)$$

Stress concentrations can also occur in machine elements under loadings that produce shear stresses. By analogy to Eq. (6.21), the design shear stress (τ_{xy}) is given by Eq. (6.22) as

$$\tau_{xy} = K_{ts} \tau_o \quad (6.22)$$

where (K_{ts}) is a stress-concentration factor in shear, and (τ_o) is the shear stress at a change in the geometry of the machine element.

For many common changes in geometry, stress-concentration factors, both (K_t) and (K_{ts}), have been developed (see Marks or Peterson, 1974). Stress-concentration factors are dependent on the geometry of the machine element, not on the material used. However, some materials are more sensitive to stress concentrations, or notches, so the stress-concentration factors will be modified according to their *notch sensitivity*.

U.S. Customary	SI/Metric
<p>Example 1. For the rectangular bar with a transverse hole in Fig. 6.18 loaded in tension, calculate the axial stress (σ_{axial}), the stress at the hole (σ_o), and the design normal stress (σ_{xx}) using Eqs. (6.19), (6.20), and (6.21), where</p> <p>$P = 1,200$ lb $w = 3$ in $t = 0.25$ in $d = 1$ in $K_t = 2.35$</p> <p>solution <i>Step 1.</i> Using Eq. (6.19) calculate the axial stress (σ_{axial}) as</p> $\sigma_{axial} = \frac{P}{A} = \frac{P}{wt} = \frac{1,200 \text{ lb}}{(3 \text{ in})(0.25 \text{ in})}$ $= \frac{1,200 \text{ lb}}{0.75 \text{ in}^2} = 1,600 \text{ lb/in}^2$ $= 1.6 \text{ kpsi}$ <p><i>Step 2.</i> Using Eq. (6.20) calculate the stress at the hole (σ_o) as</p> $\sigma_o = \frac{P}{A_o} = \frac{P}{(w-d)(t)}$ $= \frac{1,200 \text{ lb}}{([3 - 1] \text{ in})(0.25 \text{ in})}$ $= \frac{1,200 \text{ lb}}{0.5 \text{ in}^2} = 2,400 \text{ lb/in}^2$ $= 2.4 \text{ kpsi}$ <p><i>Step 3.</i> Using Eq. (6.21) calculate the design normal stress (σ_{xx}) as</p> $\sigma_{xx} = K_t \sigma_o = (2.35)(2.4 \text{ kpsi})$ $= 5.6 \text{ kpsi}$	<p>Example 1. For the rectangular bar with a transverse hole in Fig. 6.18 loaded in tension, calculate the axial stress (σ_{axial}), the stress at the hole (σ_o), and the design normal stress (σ_{xx}) using Eqs. (6.19), (6.20), and (6.21), where</p> <p>$P = 5,400$ N $w = 7.5$ cm = 0.075 m $t = 0.6$ cm = 0.006 m $d = 2.5$ = 0.025 m $K_t = 2.35$</p> <p>solution <i>Step 1.</i> Using Eq. (6.19) calculate the axial stress (σ_{axial}) as</p> $\sigma_{axial} = \frac{P}{A} = \frac{P}{wt} = \frac{5,400 \text{ N}}{(0.075 \text{ m})(0.006 \text{ m})}$ $= \frac{5,400 \text{ N}}{0.00045 \text{ m}^2} = 12,000,000 \text{ N/m}^2$ $= 12.0 \text{ MPa}$ <p><i>Step 2.</i> Using Eq. (6.20) calculate the stress at the hole (σ_o) as</p> $\sigma_{axial} = \frac{P}{A_o} = \frac{P}{(w-d)(t)}$ $= \frac{5,400 \text{ N}}{(0.05 \text{ m})(0.006 \text{ m})}$ $= \frac{5,400 \text{ N}}{0.0003 \text{ m}^2} = 18,000,000 \text{ N/m}^2$ $= 18.0 \text{ MPa}$ <p><i>Step 3.</i> Using Eq. (6.21) calculate the design normal stress (σ_{xx}) as</p> $\sigma_{xx} = K_t \sigma_o = (2.35)(18.0 \text{ MPa})$ $= 42.3 \text{ MPa}$

Notice that the stress at the hole (σ_o) is 50 percent greater than the axial stress (σ_{axial}), and that the design normal stress ($\sigma_{x,x}$) is almost three and a half times greater than the axial stress. It should be clear that stress concentrations cannot be ignored.

Notch Sensitivity. As mentioned earlier, some brittle materials are not as sensitive to stress concentrations as others, so a *reduced* value of the stress-concentration factor (K_t), denoted (K_f), is defined in Eq. (6.23),

$$K_f = 1 + q(K_t - 1) \quad (6.23)$$

where (q) is the *notch sensitivity*. The subscript f on this reduced value of the stress-concentration factor stands for *fatigue*, which will be discussed shortly in Chap. 7. However, notch sensitivity is important to static loading conditions, just as it is to dynamic or fatigue loading conditions.

Notch sensitivity (q), which ranges from 0 to 1, is a function not only of the material but the notch radius as well. The smaller the notch radius, the smaller the value of the notch sensitivity, and therefore, the smaller the reduced value of the stress-concentration factor (K_f). Based on Eq. (6.23), a notch sensitivity of zero gives a reduced stress-concentration factor (K_f) equal to 1, meaning the material is not sensitive to notches. For a notch sensitivity of 1, the reduced stress-concentration factor (K_f) equals the geometric stress-concentration factor (K_t), meaning the material is fully sensitive to notches. Values of the notch sensitivity (q) are available in various references; however, if a value of the notch sensitivity is not known, use a value of 1 to be safe.

6.2 COLUMN BUCKLING

Column buckling occurs when a compressive axial load acting on a machine element being modeled as a column exceeds a predetermined value. This machine element typically does not fail exactly at this value; however, the design is unsafe if this value is exceeded. The discussion on column buckling will be divided into four areas.

1. Euler formula for long slender columns
2. Parabolic formula for intermediate length columns
3. Secant formula for eccentric loading
4. Compression of short columns

These four areas are primarily differentiated relative to a slenderness ratio (L/k), where (L) is the length of the column and (k) is the radius of gyration of the cross-sectional area of the column. If the cross-sectional area has a weak and a strong axis, then the radius of gyration used in the slenderness ratio should be for the weak axis. The radius of gyration (k) is found from the relationship in Eq. (6.24),

$$I = Ak^2 \quad \text{or} \quad k = \sqrt{\frac{I}{A}} \quad (6.24)$$

where (I) is the area moment of inertia and (A) is the cross-sectional area of the column.

For example, suppose the cross section of a column is rectangular as shown in Fig. 6.19. As the height (h) is larger than the width (b), the x -axis is the strong axis and the y -axis is the weak axis. Therefore, the area moment of inertia for the weak axis is given in Eq. (6.25) as

$$I_{\text{weak}} = \frac{1}{12} hb^3 \quad (6.25)$$

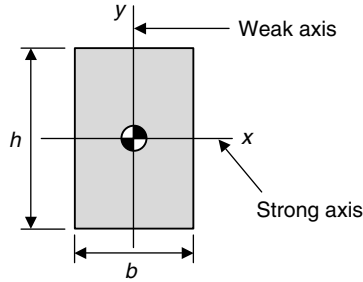

FIGURE 6.19 Rectangular cross section.

The area (A) of this rectangular cross section is (bh), so the radius of gyration (k) for the weak axis is given in Eq. (6.26) as

$$k = k_{\text{weak}} = \sqrt{\frac{I_{\text{weak}}}{A}} = \sqrt{\frac{\frac{1}{12}hb^3}{bh}} = \sqrt{\frac{1}{12}b^2} = \frac{b}{\sqrt{12}} = \frac{b}{2\sqrt{3}} \quad (6.26)$$

If the area moment of inertia for the strong axis were used in Eq. (6.26), then the radius of gyration (k_{strong}) would be too large by a factor of (h/b), where

$$k_{\text{strong}} = \frac{h}{b}k_{\text{weak}} = \frac{h}{b} \frac{b}{2\sqrt{3}} = \frac{h}{2\sqrt{3}}$$

6.2.1 Euler Formula

For long slender columns where the slenderness ratio (L/k) is greater than a certain value, for example, 130 for A36 steel or 70 for 6061-T6 aluminum, buckling of the column is predicted if the calculated axial stress (σ_{axial}) is greater than the critical stress (σ_{cr}) given in Eq. (6.27), called the Euler Buckling formula,

$$\sigma_{cr} = \frac{P_{cr}}{A} = \frac{C_{\text{ends}} \pi^2 E}{\left(\frac{L}{k}\right)^2} \quad (6.27)$$

where

$$\sigma_{\text{axial}} = \frac{P}{A} \quad (6.28)$$

and

- P = applied compressive axial force
- A = cross-sectional area of column
- P_{cr} = critical compressive axial force on column
- C_{ends} = coefficient for type of connection at each end of column
- E = modulus of elasticity of column material

There are two important points to make from Eq. (6.27). First, the only material property in this equation is the modulus of elasticity (E), so the critical stress is the same for low-strength steel as for high-strength steel. Second, as the length (L) of the column increases,

the critical stress is reduced by the inverse square, meaning that if the length is doubled the critical stress is reduced by a factor of 4.

There are four typical end-type pairs for columns: (1) pin–pin, (2) fixed–pin, (3) fixed–fixed, and (4) fixed–free, and are shown in Fig. 6.20.

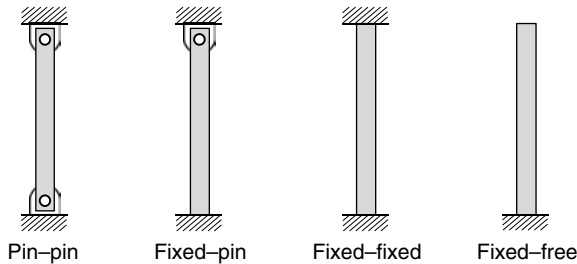

FIGURE 6.20 Column end type pairs.

The corresponding values of the coefficient (C_{ends}) are:

- | | |
|-----------------|------------|
| | C_{ends} |
| (1) pin–pin | 1 |
| (2) fixed–pin | 2 |
| (3) fixed–fixed | 4 |
| (4) fixed–free | 1/4 |

In practice, it is difficult to actually achieve a truly *fixed* end condition, so to be safe use a coefficient (C_{ends}) equal to 1, or at the most 1.2 to 1.5 for the fixed–pin or fixed–fixed conditions. Remember too that when a structure is being assembled, especially truss-like structures, all the joints start out loose, so if a higher coefficient has been used in the design phase, the structure may collapse before it can be tightened. This has happened more frequently than expected. For a fixed–free condition, it is certainly prudent to use a coefficient (C_{ends}) equal to one-quarter, as specified already.

U.S. Customary	SI/Metric
<p>Example 1. Determine whether the following rectangular ($b \times h$) column of length (L) with pin–pin ends is safe under a compressive axial force (P), where</p> <p style="margin-left: 20px;">$P = 24,000 \text{ lb}$ $L = 6 \text{ ft} = 72 \text{ in}$ $b = 1 \text{ in}$ $h = 3 \text{ in}$ $E = 30 \times 10^6 \text{ lb/in}^2 \text{ (steel)}$ $C_{ends} = 1 \text{ (pin–pin)}$</p> <p>solution <i>Step 1.</i> Using Eq. (6.26), calculate the radius of gyration (k) as</p> $k = \frac{b}{2\sqrt{3}} = \frac{1 \text{ in}}{2\sqrt{3}} = 0.29 \text{ in}$	<p>Example 1. Determine whether the following rectangular ($b \times h$) column of length (L) with pin–pin ends is safe under a compressive axial force (P), where</p> <p style="margin-left: 20px;">$P = 108,000 \text{ N}$ $L = 2 \text{ m}$ $b = 2.5 \text{ cm} = 0.025 \text{ m}$ $h = 7.5 \text{ cm} = 0.075 \text{ m}$ $E = 207 \times 10^9 \text{ N/m}^2 \text{ (steel)}$ $C_{ends} = 1 \text{ (pin–pin)}$</p> <p>solution <i>Step 1.</i> Using Eq. (6.26), calculate the radius of gyration (k) as</p> $k = \frac{b}{2\sqrt{3}} = \frac{0.025 \text{ m}}{2\sqrt{3}} = 0.0072 \text{ m}$

U.S. Customary	SI/Metric
<p><i>Step 2.</i> Calculate the slenderness ratio (L/k)</p> $\frac{L}{k} = \frac{72 \text{ in}}{0.29 \text{ in}} = 248$ <p>so the Euler's Buckling formula applies.</p> <p><i>Step 3.</i> Using Eq. (6.27), calculate the critical stress (σ_{cr}) as</p> $\begin{aligned}\sigma_{cr} &= \frac{C_{\text{ends}} \pi^2 E}{\left(\frac{L}{k}\right)^2} \\ &= \frac{(1)\pi^2(30 \times 10^6 \text{ lb/in}^2)}{(248)^2} \\ &= \frac{296 \times 10^6 \text{ lb/in}^2}{61,504} \\ &= 4,813 \text{ lb/in}^2 = 4.8 \text{ kpsi}\end{aligned}$ <p><i>Step 4.</i> Using Eq. (6.28), calculate the axial stress (σ_{axial}) as</p> $\begin{aligned}\sigma_{\text{axial}} &= \frac{P}{A} = \frac{24,000 \text{ lb}}{(1 \text{ in})(3 \text{ in})} \\ &= 8,000 \text{ lb/in}^2 = 8.0 \text{ kpsi}\end{aligned}$ <p><i>Step 5.</i> Comparing the critical stress found in step 3 with the axial stress found in step 4, it is clear the design is unsafe as</p> $\sigma_{\text{axial}} > \sigma_{cr}$	<p><i>Step 2.</i> Calculate the slenderness ratio (L/k)</p> $\frac{L}{k} = \frac{2 \text{ m}}{0.0072 \text{ m}} = 278$ <p>so the Euler's Buckling formula applies.</p> <p><i>Step 3.</i> Using Eq. (6.27), calculate the critical stress (σ_{cr}) as</p> $\begin{aligned}\sigma_{cr} &= \frac{C_{\text{ends}} \pi^2 E}{\left(\frac{L}{k}\right)^2} \\ &= \frac{(1)\pi^2(207 \times 10^9 \text{ N/m}^2)}{(278)^2} \\ &= \frac{2,043 \times 10^9 \text{ N/m}^2}{77,284} \\ &= 26,435,000 \text{ N/m}^2 = 26.4 \text{ MPa}\end{aligned}$ <p><i>Step 4.</i> Using Eq. (6.28), calculate the axial stress (σ_{axial}) as</p> $\begin{aligned}\sigma_{\text{axial}} &= \frac{P}{A} = \frac{108,000 \text{ N}}{(0.025 \text{ m})(0.075 \text{ m})} \\ &= 57,600,000 \text{ N/m}^2 = 57.6 \text{ MPa}\end{aligned}$ <p><i>Step 5.</i> Comparing the critical stress found in step 3 with the axial stress found in step 4, it is clear the design is unsafe as</p> $\sigma_{\text{axial}} > \sigma_{cr}$

6.2.2 Parabolic Formula

For columns where the slenderness ratio (L/k) is less than a certain value, the Euler formula does not accurately predict column buckling. As mentioned earlier, the Euler formula given in Eq. (6.27) states that the critical stress (σ_{cr}) is inversely proportional to the square of the slenderness ratio (L/k). This inverse relationship is presented graphically in Fig. 6.21 as the curve from point A to point B .

The lower limit of the slenderness ratio for which the Euler formula is appropriate is indicated by point D , denoted $(L/k)_D$, where the critical stress is set equal to the yield stress divided by two ($S_y/2$). The value of the slenderness ratio at this point is given in Eq. (6.29).

$$\left(\frac{L}{k}\right)_D = \left(\frac{2\pi^2 CE}{S_y}\right)^{1/2} \quad (6.29)$$

Also shown in Fig. 6.21 is point C , also on the Euler curve, that defines a slenderness ratio, denoted $(L/k)_C$, where the critical stress has been set equal to the yield stress (S_y).

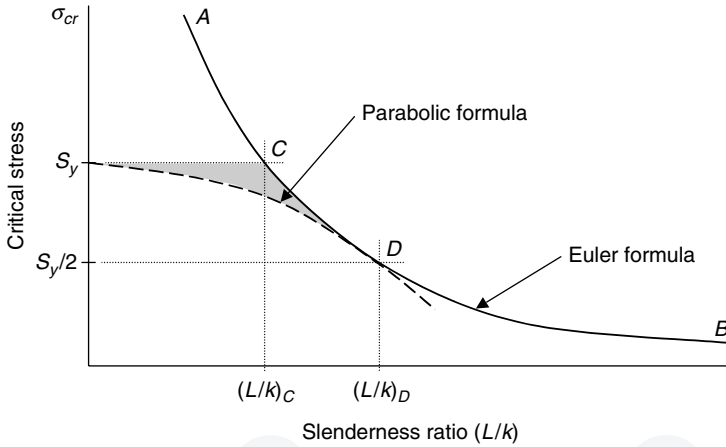

FIGURE 6.21 Euler and parabolic formulas.

The value of the slenderness ratio at this point is given in Eq. (6.30).

$$\left(\frac{L}{k}\right)_C = \left(\frac{\pi^2 CE}{S_y}\right)^{1/2} \quad (6.30)$$

If a parabola is now constructed between point *D* and the yield stress (S_y) on the critical stress (σ_{cr}) axis, then the following parabolic formula given in Eq. (6.31) will be obtained.

$$\sigma_{cr} = \frac{P_{cr}}{A} = S_y - \frac{1}{CE} \left(\frac{S_y L}{2\pi k}\right)^2 \quad (6.31)$$

Note that the values of the slenderness ratio (L/k) used in the parabolic formula given in Eq. (6.31) must be less than the value at point *D*, meaning the value denoted $(L/k)_D$ and given in Eq. (6.29).

The triangular-like region shown shaded in Fig. 6.21 is bounded by the following three points: the yield stress (S_y) point on the critical stress axis, point *C* on the Euler curve, and point *D* on both the Euler and parabolic curves. This is the region where the Euler formula might appear to be appropriate, but in practice is not. The reason for this is that columns with slenderness ratios in this region tend to be influenced more by the fact that the critical stress (σ_{cr}) is greater than the yield stress (S_y) rather than by the Euler formula buckling criteria.

There are two important points to make from Eq. (6.31). First, unlike the Euler formula, the yield stress (S_y) is important so the critical stress (σ_{cr}) for high-strength steel is greater than that for low-strength steel, even though the modulus of elasticity (E) is the same. Second, like the Euler formula, as the length (L) of the column increases, the critical stress is reduced, again as the square of the slenderness ratio.

For the following example, the cross-sectional area will be circular, so the radius of gyration (k) will be different than for a rectangular cross section given in Eq. (6.26). The area

moment of inertia for a circle is given by Eq. (6.32) as

$$I_{\text{circle}} = \frac{1}{4} \pi r^4 \quad (6.32)$$

The area (A) of this circular cross section is (πr^2), so the radius of gyration (k) for a circle is given in Eq. (6.33) as

$$k_{\text{circle}} = \sqrt{\frac{I_{\text{circle}}}{A_{\text{circle}}}} = \sqrt{\frac{\frac{1}{4} \pi r^4}{\pi r^2}} = \sqrt{\frac{1}{4} r^2} = \frac{r}{2} \quad (6.33)$$

U.S. Customary	SI/Metric
<p>Example 2. Determine whether the following circular column with diameter (d) and of length (L) with fixed-fixed ends is safe under a compressive axial force (P), where</p> <p>$P = 12,000$ lb $L = 3$ ft = 36 in $d = 2$ in $E = 10 \times 10^3$ kpsi (aluminum) $S_y = 40$ kpsi $C_{\text{ends}} = 1.5$ (fixed-fixed) adjusted</p> <p>solution <i>Step 1.</i> Using Eq. (6.33), calculate the radius of gyration (k) as</p> $k = \frac{r}{2} = \frac{1 \text{ in}}{2} = 0.5 \text{ in}$ <p><i>Step 2.</i> Calculate the slenderness ratio (L/k).</p> $\frac{L}{k} = \frac{36 \text{ in}}{0.5 \text{ in}} = 72$ <p><i>Step 3.</i> Calculate the minimum slenderness ratio ($(L/k)_D$) for the Euler formula from Eq. (6.29).</p> $\begin{aligned} \left(\frac{L}{k}\right)_D &= \left(\frac{2\pi^2 CE}{S_y}\right)^{1/2} \\ &= \left(\frac{2\pi^2(1.5)(10 \times 10^6 \text{ psi})}{40,000 \text{ psi}}\right)^{1/2} \\ &= \left(\frac{296 \times 10^6 \text{ psi}}{40,000 \text{ psi}}\right)^{1/2} \\ &= (740)^{1/2} = 86 \end{aligned}$	<p>Example 2. Determine whether the following circular column, with diameter (d), and of length (L) with fixed-fixed ends is safe under a compressive axial force (P), where</p> <p>$P = 54,000$ N $L = 1$ m $d = 5$ cm = 0.05 m $E = 70 \times 10^3$ MPa (aluminum) $S_y = 270$ MPa $C_{\text{ends}} = 1.5$ (fixed-fixed) adjusted</p> <p>solution <i>Step 1.</i> Using Eq. (6.33), calculate the radius of gyration (k) as</p> $k = \frac{r}{2} = \frac{0.025 \text{ m}}{2} = 0.0125 \text{ m}$ <p><i>Step 2.</i> Calculate the slenderness ratio (L/k).</p> $\frac{L}{k} = \frac{1 \text{ m}}{0.0125 \text{ m}} = 80$ <p><i>Step 3.</i> Calculate the minimum slenderness ratio ($(L/k)_D$) for the Euler formula from Eq. (6.29).</p> $\begin{aligned} \left(\frac{L}{k}\right)_D &= \left(\frac{2\pi^2 CE}{S_y}\right)^{1/2} \\ &= \left(\frac{2\pi^2(1.5)(70 \times 10^3 \text{ MPa})}{270 \text{ MPa}}\right)^{1/2} \\ &= \left(\frac{207.3 \times 10^4 \text{ MPa}}{270 \text{ MPa}}\right)^{1/2} \\ &= (7,676)^{1/2} = 88 \end{aligned}$

U.S. Customary	SI/Metric
<p>As the slenderness ratio calculated in step 2 is less than the minimum value found in step 3 for the Euler formula, the parabolic formula applies.</p> <p><i>Step 4.</i> Using Eq. (6.31), calculate the critical stress (σ_{cr}) as</p> $\begin{aligned}\sigma_{cr} &= S_y - \frac{1}{CE} \left(\frac{S_y L}{2\pi k} \right)^2 \\ &= (40 \text{ kpsi}) - \frac{1}{(1.5)(10 \times 10^3 \text{ kpsi})} \\ &\quad \times \left(\frac{40 \text{ kpsi}}{2\pi} (72) \right)^2 \\ &= (40 \text{ kpsi}) - \frac{1}{(15 \times 10^3 \text{ kpsi})} \\ &\quad \times (458 \text{ kpsi})^2 \\ &= (40 \text{ kpsi}) - \frac{21 \times 10^4 \text{ kpsi}^2}{15 \times 10^3 \text{ kpsi}} \\ &= (40 \text{ kpsi}) - (14 \text{ kpsi}) \\ &= 26 \text{ kpsi}\end{aligned}$ <p><i>Step 5.</i> Using Eq. (6.28), calculate the axial stress (σ_{axial}) as</p> $\begin{aligned}\sigma_{axial} &= \frac{P}{A} = \frac{12,000 \text{ lb}}{\pi (1 \text{ in})^2} \\ &= 3,820 \text{ lb/in}^2 = 3.8 \text{ kpsi}\end{aligned}$ <p><i>Step 6.</i> Comparing the critical stress found in step 4 with the axial stress found in step 5, the design is safe as</p> $\sigma_{axial} < \sigma_{cr}$	<p>As the slenderness ratio calculated in step 2 is less than the minimum value found in step 3 for the Euler formula, the parabolic formula applies.</p> <p><i>Step 4.</i> Using Eq. (6.31), calculate the critical stress (σ_{cr}) as</p> $\begin{aligned}\sigma_{cr} &= S_y - \frac{1}{CE} \left(\frac{S_y L}{2\pi k} \right)^2 \\ &= (270 \text{ MPa}) - \frac{1}{(1.5)(70 \times 10^3 \text{ MPa})} \\ &\quad \times \left(\frac{270 \text{ MPa}}{2\pi} (80) \right)^2 \\ &= (270 \text{ MPa}) - \frac{1}{(105 \times 10^3 \text{ MPa})} \\ &\quad \times (3,438 \text{ MPa})^2 \\ &= (270 \text{ MPa}) - \frac{11,820 \times 10^3 \text{ MPa}^2}{105 \times 10^3 \text{ MPa}} \\ &= (270 \text{ MPa}) - (113 \text{ MPa}) \\ &= 157 \text{ MPa}\end{aligned}$ <p><i>Step 5.</i> Using Eq. (6.28), calculate the axial stress (σ_{axial}) as</p> $\begin{aligned}\sigma_{axial} &= \frac{P}{A} = \frac{54,000 \text{ N}}{\pi (0.025 \text{ m})^2} \\ &= 27,500,000 \text{ N/m}^2 = 27.5 \text{ MPa}\end{aligned}$ <p><i>Step 6.</i> Comparing the critical stress found in step 4 with the axial stress found in step 5, the design is safe as</p> $\sigma_{axial} < \sigma_{cr}$

6.2.3 Secant Formula

The Euler and parabolic formulas are based on a column that is perfectly straight and is loaded directly along the axis of the column. However, if the column has eccentricities, either produced during manufacture or assembly, or an eccentricity in the application of the compressive load, the column can fail at a critical stress (σ_{cr}) value lower than predicted by either the Euler or parabolic formulas.

Without providing the details of its development, the appropriate formula for columns with an eccentricity, called the secant formula, is given in Eq. (6.34) as

$$\sigma_{cr} = \frac{P_{cr}}{A} = \frac{S_y}{1 + \left(\frac{ec}{k^2} \right) s \left[\frac{1}{2} \left(\frac{L}{k} \right) \sqrt{\frac{\sigma_{cr}}{E}} \right]} \quad (6.34)$$

where e = eccentricity

c = maximum distance from the neutral axis to farthest point in cross section

$\frac{ec}{k^2}$ = eccentricity ratio

The other terms in Eq. (6.34) are as already defined. Note the *secant* function in the denominator; that is where its name is derived from. (The secant function is the inverse of the cosine function, so at zero the secant is 1, and then becomes very large as it approaches $[\pi/2]$.)

The secant formula in Eq. (6.34) cannot be solved explicitly for the critical stress (σ_{cr}). Either a trial-and-error method or numerical methods are suggested in most references. Actually, the trial-and-error method is easy to employ, at least to an accuracy needed in the design of a machine element, so there is no need to be intimidated by the prospects of doing numerical methods.

The mathematical nature of the secant formula means that if a particular material is regularly used for a class of columns, then to avoid repetitive trial-and-error solutions a set of design curves for various values of the eccentricity ratio ec/k^2 is recommended, like those shown in Fig. 6.22.

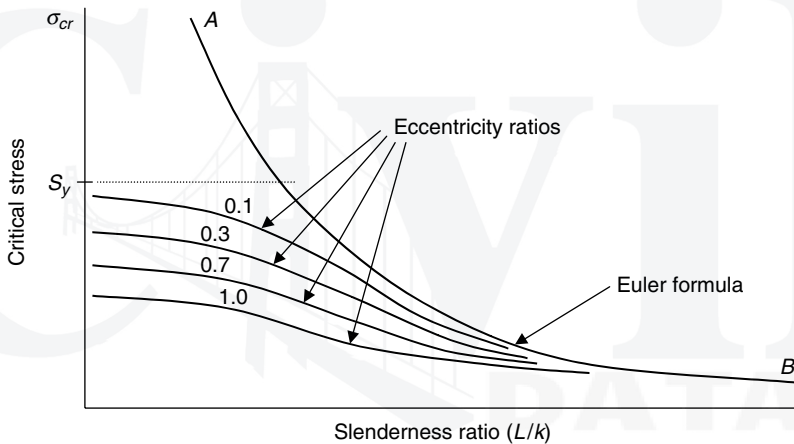

FIGURE 6.22 Euler and secant formulas.

Notice that as the slenderness ratio (L/k) increases, the series of secant formula curves for various eccentricity ratios approach the Euler formula curve asymptotically. For large values of the slenderness ratio, the Euler formula becomes the appropriate criteria for buckling.

There are two important points to make from Eq. (6.34). First, like the parabolic formula, the yield stress (S_y) is important so the critical stress (σ_{cr}) for high-strength steel is greater than that for low-strength steel, even though the modulus of elasticity (E) is the same. Second, as the length (L) increases the effect of the eccentricity (e) increases. This is because the column is not only subjected to an axial loading, but to a bending moment load as a result of deformation of the column before buckling.

U.S. Customary

Example 3. Determine the critical stress (σ_{cr}) using the secant formula for the column in Example 2 if there is an eccentricity (e) of 0.25 in, and where it was found that the radius of gyration (k) was (0.5 in) and the slenderness ratio (L/k) was (72). The yield stress (S_y)

was given as (40 kpsi) and the modulus of elasticity (E) was (10×10^3 kpsi). The distance (c) for a circle is the radius (r), which in Example 2 is (1 in).

solution

Step 1. Calculate the eccentricity ratio $\frac{ec}{k^2}$ as

$$\frac{ec}{k^2} = \frac{(0.25 \text{ in})(1 \text{ in})}{(0.5 \text{ in})^2} = 1$$

Step 2. Substitute the eccentricity ratio found in step 1 and the known values of the other terms in Eq. (6.10) to give Eq. (6.8) as

$$\begin{aligned} \sigma_{cr} &= \frac{S_y}{1 + \left(\frac{ec}{k^2}\right) s \left[\frac{1}{2} \left(\frac{L}{k}\right) \sqrt{\frac{\sigma_{cr}}{E}} \right]} \\ &= \frac{40 \text{ kpsi}}{1 + (1) s \left[\frac{1}{2} (72) \sqrt{\frac{\sigma_{cr}}{10 \times 10^3 \text{ kpsi}}} \right]} \\ &= \frac{40 \text{ kpsi}}{1 + s \left[\frac{(72)}{2(100)} \sqrt{\sigma_{cr}} \right]} \\ &= \frac{40 \text{ kpsi}}{1 + s [(0.36) \sqrt{\sigma_{cr}}]} \end{aligned} \quad (6.35)$$

where the units (kpsi) have been dropped for the modulus of elasticity (E) in the square root term because the critical stress (σ_{cr}) will also have units of (kpsi). This is compatible with the fact that the secant can only be evaluated for a nondimensional quantity.

As the critical stress (σ_{cr}) is on both sides of Eq. (6.8), it must be solved by trial-and-error or some other numerical method. To show how quickly the trial-and-error method can obtain a reasonably accurate value for the critical stress, start with an *educated* guess for the critical stress, then modify this guess in successive iterations until the guess equals the right hand side of Eq. (6.35). Stop when an appropriate level of accuracy is reached.

An excellent *educated* guess would be the yield stress divided by two, which would be 20 kpsi. Substitute the value 20 in the right hand side of Eq. (6.35) to give

$$\begin{aligned} \sigma_{cr} &= \frac{40 \text{ kpsi}}{1 + s [(0.36) \sqrt{\sigma_{cr}}]} \\ 20 &= \frac{40 \text{ kpsi}}{1 + s [(0.36) \sqrt{20}]} = \frac{40 \text{ kpsi}}{1 + s [1.61]} = \frac{40 \text{ kpsi}}{1 + (-25.5)} = \frac{40 \text{ kpsi}}{-24.5} \\ &= -1.6 \end{aligned}$$

As the right hand side came out negative, try a new guess of 10.

$$\begin{aligned} \sigma_{cr} &= \frac{40 \text{ kpsi}}{1 + s [(0.36) \sqrt{\sigma_{cr}}]} \\ 10 &= \frac{40 \text{ kpsi}}{1 + s [(0.36) \sqrt{10}]} = \frac{40 \text{ kpsi}}{1 + s [1.14]} = \frac{40 \text{ kpsi}}{1 + (2.4)} = \frac{40 \text{ kpsi}}{3.4} \\ &= 11.8 \end{aligned}$$

As the right hand side came out just slightly greater than the guess, try 11.

$$\begin{aligned}\sigma_{cr} &= \frac{40 \text{ kpsi}}{1 + s [(0.36)\sqrt{\sigma_{cr}}]} \\ 11 &= \frac{40 \text{ kpsi}}{1 + s [(0.36)\sqrt{11}]} = \frac{40 \text{ kpsi}}{1 + s [1.194]} = \frac{40 \text{ kpsi}}{1 + (2.72)} = \frac{40 \text{ kpsi}}{3.72} \\ &= 10.8\end{aligned}$$

To get one decimal place accuracy, try as a last guess, 10.9.

$$\begin{aligned}\sigma_{cr} &= \frac{40 \text{ kpsi}}{1 + s [(0.36)\sqrt{\sigma_{cr}}]} \\ 10.9 &= \frac{40 \text{ kpsi}}{1 + s [(0.36)\sqrt{10.9}]} = \frac{40 \text{ kpsi}}{1 + s [1.188]} = \frac{40 \text{ kpsi}}{1 + (2.68)} = \frac{40 \text{ kpsi}}{3.68} \\ &= 10.9 \\ &= \sigma_{cr}\end{aligned}$$

Notice that it required only four iterations to get one decimal place accuracy for the critical stress. Also, this value of the critical stress would still predict a safe design.

SI/Metric

Example 3. Determine the critical stress (σ_{cr}) using the secant formula for the column in Example 2 if there is an eccentricity (e) of 0.01 m, and where it was found that the radius of gyration (k) was (0.0125 m) and the slenderness ratio (L/k) was (80). The yield stress (S_y) was given as (270 MPa) and the modulus of elasticity (E) was (70×10^3 MPa). The distance (c) for a circle is the radius (r), which in Example 2 is (0.025 m).

solution

Step 1. Calculate the eccentricity ratio $\frac{ec}{k^2}$ as

$$\frac{ec}{k^2} = \frac{(0.01 \text{ m})(0.025 \text{ m})}{(0.0125 \text{ m})^2} = 1.6$$

Step 2. Substitute the eccentricity ratio found in step 1 and the known values of the other terms in Eq. (6.34) to give Eq. (6.36) as

$$\begin{aligned}\sigma_{cr} &= \frac{S_y}{1 + \left(\frac{ec}{k^2}\right) s \left[\frac{1}{2} \left(\frac{L}{k}\right) \sqrt{\frac{\sigma_{cr}}{E}} \right]} \\ &= \frac{270 \text{ MPa}}{1 + (1.6) s \left[\frac{1}{2} (80) \sqrt{\frac{\sigma_{cr}}{70 \times 10^3 \text{ MPa}}} \right]} \\ &= \frac{270 \text{ MPa}}{1 + (1.6) s \left[\frac{(80)}{2(264.6)} \sqrt{\sigma_{cr}} \right]} \\ &= \frac{270 \text{ MPa}}{1 + (1.6) s [(0.15)\sqrt{\sigma_{cr}}]}\end{aligned} \tag{6.36}$$

where the units (MPa) have been dropped for the modulus of elasticity (E) in the square root term as the critical stress (σ_{cr}) will also have units of (MPa). This is compatible with the fact that the secant can only be evaluated for a nondimensional quantity.

As the critical stress (σ_{cr}) is on both sides of Eq. (6.36) it must be solved by trial and error or some other numerical method. To show how quickly the trial-and-error method can obtain a reasonably accurate value for the critical stress, start with an *educated* guess for the critical stress, then modify this guess in successive iterations until the guess equals the right hand side of Eq. (6.36). Stop when an appropriate level of accuracy is reached.

An excellent *educated* guess would be the yield stress divided by two, which would be 135 MPa. Substitute this value into the right hand side of Eq. (6.36) to give

$$\begin{aligned}\sigma_{cr} &= \frac{270 \text{ MPa}}{1 + (1.6) s [(0.15)\sqrt{\sigma_{cr}}]} \\ 135 &= \frac{270 \text{ MPa}}{1 + (1.6) s [(0.15)\sqrt{135}]} = \frac{270 \text{ MPa}}{1 + (1.6) s [1.74]} = \frac{270 \text{ MPa}}{1 + (-9.3)} \\ &= \frac{270 \text{ MPa}}{-8.3} = -32.4\end{aligned}$$

As the right hand side came out negative, try a new guess of 70.

$$\begin{aligned}\sigma_{cr} &= \frac{270 \text{ MPa}}{1 + (1.6) s [(0.15)\sqrt{\sigma_{cr}}]} \\ 70 &= \frac{270 \text{ MPa}}{1 + (1.6) s [(0.15)\sqrt{70}]} = \frac{270 \text{ MPa}}{1 + (1.6) s [1.25]} = \frac{270 \text{ MPa}}{1 + (5.15)} \\ &= \frac{270 \text{ MPa}}{6.15} = 43.9\end{aligned}$$

Split the difference between 70 and 43.9 and try 57.

$$\begin{aligned}\sigma_{cr} &= \frac{270 \text{ MPa}}{1 + (1.6) s [(0.15)\sqrt{\sigma_{cr}}]} \\ 57 &= \frac{270 \text{ MPa}}{1 + (1.6) s [(0.15)\sqrt{57}]} = \frac{270 \text{ MPa}}{1 + (1.6) s [1.13]} = \frac{270 \text{ MPa}}{1 + (3.77)} \\ &= \frac{270 \text{ MPa}}{4.77} = 56.6 = \sigma_{cr}\end{aligned}$$

Notice that it required only three iterations, compared to four iterations for the U.S. Customary calculation, to get one decimal place accuracy for the critical stress. Also, this value of the critical stress would still predict a safe design.

6.2.4 Short Columns

The big question is how short is short? The machine element could be so short that it can be considered as a pure compression member, where failure is a shortening of the column at the yield stress (S_y).

For columns having slenderness ratios between for pure compression and for one which would mean that the secant formula would apply, the critical stress (σ_{cr})

is given by Eq. (6.37) as

$$\sigma_{cr} = \frac{P_{cr}}{A} = \frac{S_y}{1 + \left(\frac{ec}{k^2}\right)} \quad (6.37)$$

Notice that Eq. (6.37) does not contain the length (L) or the slenderness ratio (L/k), so an artificial value of a transition slenderness ratio must be established. If the amount of lateral deflection owing to bending from the axis of the compressive loading is to be some percentage of the eccentricity (e), then if this percentage is 1 percent, the transition slenderness ratio is given by Eq. (6.38) as

$$\left(\frac{L}{k}\right)_{\text{transition}} = 0.282 \left(\frac{E}{\sigma_{cr}}\right) \quad (6.38)$$

If the slenderness ratio is less than this transition value, then the column is short. However, if the slenderness ratio is greater than this transition value, then the secant formula applies.

U.S. Customary	SI/Metric
<p>Example 4. Determine whether the column in Example 2 is short, where</p> <p style="padding-left: 40px;">eccentricity ratio = 1 $S_y = 40$ kpsi $E = 10 \times 10^3$ kpsi</p> <p>solution</p> <p><i>Step 1.</i> Using Eq. (6.37), calculate the critical stress as</p> $\sigma_{cr} = \frac{P_{cr}}{A} = \frac{S_y}{1 + \left(\frac{ec}{k^2}\right)}$ $= \frac{40 \text{ kpsi}}{1 + (1)} = \frac{40 \text{ kpsi}}{2} = 20 \text{ kpsi}$ <p><i>Step 2.</i> Using the critical stress found in step 1 calculate the transition slenderness ratio using Eq. (6.38).</p> $\left(\frac{L}{k}\right)_{\text{transition}} = 0.282 \left(\frac{E}{\sigma_{cr}}\right)$ $= 0.282 \left(\frac{10 \times 10^3 \text{ kpsi}}{20 \text{ kpsi}}\right)$ $= 0.282 (50) = 14$ <p><i>Step 3.</i> As the transition slenderness ratio is less than the slenderness ratio from Example 2, the column is not short.</p>	<p>Example 4. Determine whether the column in Example 2 is short, where</p> <p style="padding-left: 40px;">eccentricity ratio = 1.6 $S_y = 270$ MPa $E = 70 \times 10^3$ MPa</p> <p>solution</p> <p><i>Step 1.</i> Using Eq. (6.37), calculate the critical stress as</p> $\sigma_{cr} = \frac{P_{cr}}{A} = \frac{S_y}{1 + \left(\frac{ec}{k^2}\right)}$ $= \frac{270 \text{ MPa}}{1 + (1.6)} = \frac{270 \text{ MPa}}{2.6} = 104 \text{ MPa}$ <p><i>Step 2.</i> Using the critical stress found in step 1 calculate the transition slenderness ratio using Eq. (6.38).</p> $\left(\frac{L}{k}\right)_{\text{transition}} = 0.282 \left(\frac{E}{\sigma_{cr}}\right)$ $= 0.282 \left(\frac{70 \times 10^3 \text{ MPa}}{104 \text{ MPa}}\right)$ $= 0.282 (673) = 190$ <p><i>Step 3.</i> As the transition slenderness ratio is greater than the slenderness ratio from Example 2, the column is short.</p>



CHAPTER 7

FATIGUE AND DYNAMIC DESIGN

7.1 INTRODUCTION

A machine element may have been designed to be safe under static conditions, only to fail under repeated dynamic loading, called a fatigue failure. This repeated loading could be a complete reversal of the load, be a fluctuating load, or be due to a combination of loadings. The loading may produce either normal stresses or shear stresses, or the loading can produce a combination of both normal and shear stresses so that either by Mohr's circle or by the appropriate equations the principal stresses are found. All of these types of loading conditions will be discussed in this section.

If the design of a machine element becomes unsafe under dynamic conditions, it usually fails suddenly and below the static strengths of the material, either the yield strength (S_y) for ductile materials or the ultimate tensile strength (S_{ut}) for brittle materials. It is interesting, although not unexpected, that a brittle material would fail suddenly under either static or dynamic conditions. Ductile materials fail as if they were brittle from excessive repeated loading at a stress level below the yield strength (S_y). The most accepted method of determining this critical stress level will be presented shortly.

The mode of failure under dynamic conditions appears to be a result of a very small crack, too small to see with the naked eye, developing at a point where the geometry of the machine element changes, usually on the surface. A crack can even develop at a part identification stamp, or at a surface scratch accidentally put on the part during assembly or repair. Under repeated loading, this crack grows due to stress concentrations until the area over which the load must be carried is reduced rapidly, causing the stress to increase just as rapidly. Sudden failure, without any warning, occurs when the stress level exceeds a critical value for a specified number of cycles. Therefore, a fatigue failure can be differentiated visually from a static failure by the appearance of two regions on the failed part. The first region is due to the propagation of the crack, and the second region is due to the sudden fracture, not unlike what would be seen in the static failure of a brittle material, such as cast iron. This is in contrast to what would be seen in the static failure of a ductile material, where considerable yielding would be visible.

Some materials, like steel, have a critical stress value, which if never exceeded, ensure the machine element has an infinite life. For other materials, like aluminum, there is no such value at any number of cycles so the machine element will fail at some point no matter how low the stress level is kept.

The study of fatigue is relatively recent and commenced only post-World War II. However, some machines designed even in the middle-to-late nineteenth century have been operating

over very long periods of time. Unknowingly, the designers of these machines used such large factors-of-safety that the stress levels were kept below a value that allowed an infinite life of the machine. This was clearly the source of the first law of machine design: “When in doubt, make it stout!”

7.2 REVERSED LOADING

The first type of dynamic loading to be presented is called reversed loading, where the load on the machine element varies from some positive value to the same value but negative, and back. The cycle repeats itself some number of times, or cycles, denoted (N). Three square wave cycles of this type of loading are shown in Fig. 7.1, where the mean stress (σ_m) is zero and the amplitude stress (σ_a) is the magnitude of the stress (σ) produced by the reversed loading.

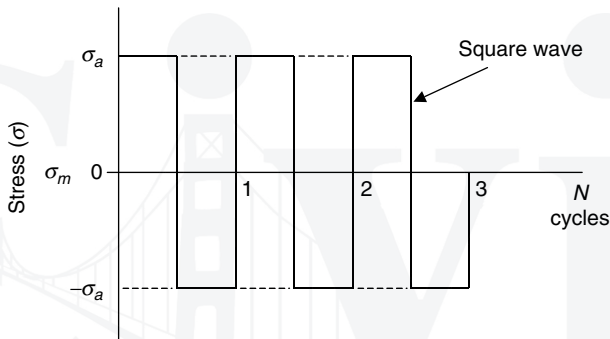

FIGURE 7.1 Reversed loading (square wave).

The reversed loading could also be represented by a saw tooth wave form like that shown in Fig. 7.2, or as the sinusoidal wave form shown in Fig. 7.3, which is the most common form, and is the basis for determining the critical level of stress for a safe design under dynamic conditions. However, whatever wave form the reversed loading represents,

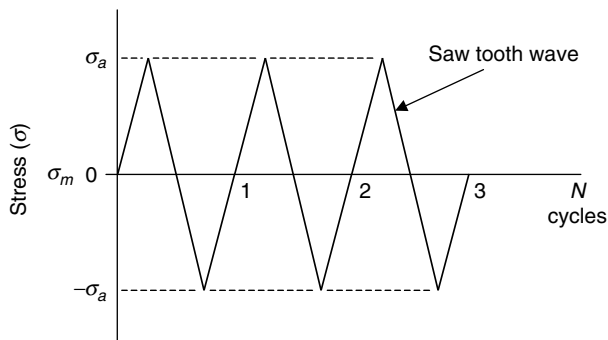

FIGURE 7.2 Reversed loading (saw tooth wave).

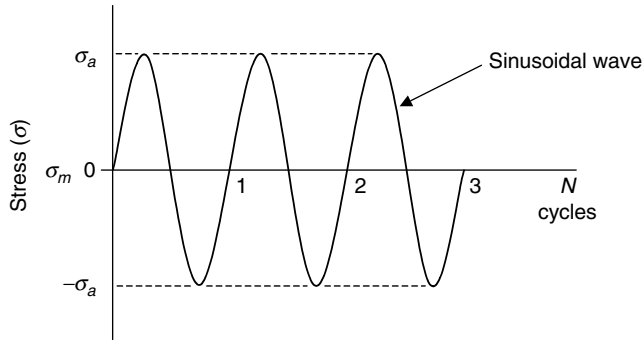

FIGURE 7.3 Reversed loading (sinusoidal wave).

the analysis that follows requires that the loading be periodic, with a constant period over the entire range of the number of cycles.

S-N Diagram. To determine the critical level of stress under repeated reversed loading, an experimental testing device called the R. R. Moore rotating-beam machine is used. The principle of its design is that bending of a test specimen with a symmetrical cross-sectional area produces a positive normal stress on one side, an equal negative normal stress on the other side, and zero stress at the neutral axis. If this test specimen under bending is then rotated about its neutral axis, it will experience repeated reversed loading. A typical test specimen for the R. R. Moore rotating-beam machine, of which many are needed to determine the critical level of stress, is shown in Fig. 7.4.

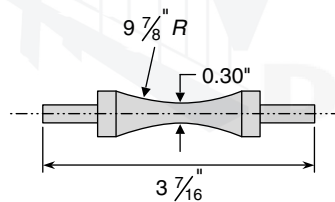

FIGURE 7.4 Test specimen for R. R. Moore rotating-beam machine.

To obtain the necessary data to determine the critical level of stress for repeated reversed loading, the testing begins with a bending load on the first test specimen that produces failure in the first revolution, or cycle, meaning ($N = 1$). The corresponding stress at failure, called the fatigue strength (S_f), is recorded. This fatigue strength for ($N = 1$) is actually the ultimate tensile strength (S_{ut}).

The bending load is then reduced for the second test specimen, and the number of cycles (N) and corresponding stress at failure, meaning the fatigue strength, is recorded. This process continues until a sufficient number of data points are available, which are then plotted in an S-N diagram, where the S stands for strength and N for the number of cycles. It turns out that plotting these points on a log-log grid, as shown in Fig. 7.5, is best. The three straight lines shown connect data points (not shown) for a particular type of steel.

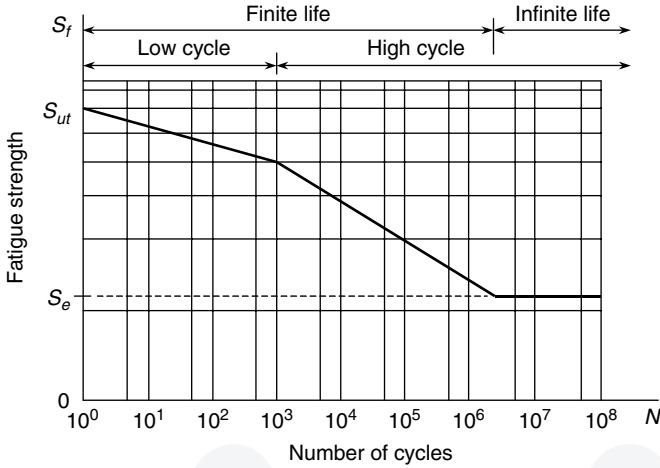

FIGURE 7.5 S-N diagram (steel).

Notice that there are two types of regions identified in an S-N diagram. One region separates *low cycle* loading from *high cycle* loading at ($N = 10^3$) cycles, whereas the other region separates *finite life* from *infinite life* somewhere between ($N = 10^6$) cycles and ($N = 10^7$) cycles. The exact points of separation for these two regions are dependent on the specific material being tested.

The most important thing to observe in an S-N diagram, if the material being tested is ferrous like steel, is that the straight line at the lower right of the diagram becomes horizontal somewhere between ($N = 10^6$) cycles and ($N = 10^7$) cycles and stays horizontal thereafter. This means there is a stress level, called the endurance limit (S_e), that if the stress in the test specimen is reduced to below this value the specimen never fails. This means it has an infinite life. Unfortunately, for nonferrous materials like aluminum there is no endurance limit, meaning the test specimen will eventually fail at some number of cycles, usually near ($N = 10^8$) cycles, no matter how much the stress level is reduced. This is why critical aluminum parts, especially those in aircraft where the number of reversed loadings can become very high in a short period of time, must be inspected regularly and replaced prior to reaching an unsafe number of cycles.

Endurance Limit. A sufficient number of ferrous materials (carbon steels, alloy steels, and wrought irons) have been tested using the R. R. Moore rotating-beam machine so that the following relationship between the ultimate tensile strength (S_{ut}) and the endurance limit (S'_e) that would have been obtained from a fatigue test can be assumed to give an accurate value even if the material has not been tested. This relationship is given in Eq. (7.1) for both the U.S. Customary and SI/metric system of units.

$$\begin{aligned}
 \text{U.S. Customary : } S'_e &= \begin{cases} 0.504 S_{ut} & S_{ut} \leq 200 \text{ kpsi} \\ 100 \text{ kpsi} & S_{ut} > 200 \text{ kpsi} \end{cases} \\
 \text{SI/metric : } S'_e &= \begin{cases} 0.504 S_{ut} & S_{ut} \leq 1400 \text{ MPa} \\ 700 \text{ MPa} & S_{ut} > 1400 \text{ MPa} \end{cases}
 \end{aligned} \tag{7.1}$$

Note that the *prime* on the endurance limit (S'_e) in Eq. (7.1) differentiates the endurance limit obtained from a fatigue test and the actual endurance limit (S_e) for a machine element that usually differs in surface finish, size, loading, temperature, and other miscellaneous effects from the test specimen. These factors, which modify the value of the endurance limit (S'_e) obtained from Eq. (7.1), will be discussed shortly.

To get a feel of the difference between ($N = 10^3$) cycles and ($N = 10^6$) cycles, consider the following example.

U.S. Customary	SI/Metric
<p>Example 1. How far must a car be driven at 30 mph at an engine speed of 2,500 rpm for the crankshaft to rotate 10^6 cycles? How far for 10^3 cycles? How long will each take?</p> <p>solution</p> <p><i>Step 1.</i> Convert mph to mi/rev.</p> $30 \frac{\text{mi}}{\text{h}} \times \frac{1 \text{ h}}{60 \text{ min}} \times \frac{1 \text{ min}}{2,500 \text{ rev}} = \frac{1}{5,000} \frac{\text{mi}}{\text{rev}}$ <p><i>Step 2.</i> Multiply the mi/rev found in step 1 by 10^6 cycles or revolutions to find the distance traveled as</p> $\text{dist}_{10^6} = \frac{1}{5,000} \frac{\text{mi}}{\text{rev}} \times 10^6 \text{ rev} = 200 \text{ mi}$ <p><i>Step 3.</i> Multiply the mi/rev found in step 1 by 10^3 cycles or revolutions to find the distance traveled as</p> $\text{dist}_{10^3} = \frac{1}{5,000} \frac{\text{mi}}{\text{rev}} \times 10^3 \text{ rev} = 0.2 \text{ mi}$ $= 1,056 \text{ ft}$ <p><i>Step 4.</i> Divide the distance found in step 2 by 30 mph to find the time for 10^6 cycles</p> $\text{time}_{10^6} = \frac{200 \text{ mi}}{30 \text{ mi/h}} = 6.7 \text{ h}$ <p><i>Step 5.</i> Divide the distance found in step 3 by 30 mph to find the time 10^3 cycles</p> $\text{time}_{10^3} = \frac{0.2 \text{ mi}}{30 \text{ mi/h}} = 0.0067 \text{ h}$ $= 0.4 \text{ min} = 24 \text{ s}$	<p>Example 1. How far must a car be driven at 50 kph at an engine speed of 2,500 rpm for the crankshaft to rotate 10^6 cycles? How far for 10^3 cycles? How long will each take?</p> <p>solution</p> <p><i>Step 1.</i> Convert kph to km/rev.</p> $50 \frac{\text{km}}{\text{h}} \times \frac{1 \text{ h}}{60 \text{ min}} \times \frac{1 \text{ min}}{2,500 \text{ rev}} = \frac{1}{3,000} \frac{\text{km}}{\text{rev}}$ <p><i>Step 2.</i> Multiply the km/rev found in step 1 by 10^6 cycles or revolutions to find the distance traveled as</p> $\text{dist}_{10^6} = \frac{1}{3,000} \frac{\text{km}}{\text{rev}} \times 10^6 \text{ rev} = 333 \text{ km}$ <p><i>Step 3.</i> Multiply the mi/r found in step 1 by 10^3 cycles or revolutions to find the distance traveled as</p> $\text{dist}_{10^3} = \frac{1}{3,000} \frac{\text{km}}{\text{rev}} \times 10^3 \text{ rev} = 0.333 \text{ km}$ $= 333 \text{ m}$ <p><i>Step 4.</i> Divide the distance found in step 2 by 50 kph to find the time for 10^6 cycles</p> $\text{time}_{10^6} = \frac{333 \text{ km}}{50 \text{ km/h}} = 6.7 \text{ h}$ <p><i>Step 5.</i> Divide the distance found in step 3 by 50 kph to find the time 10^3 cycles</p> $\text{time}_{10^3} = \frac{0.333 \text{ km}}{50 \text{ km/h}} = 0.0067 \text{ h}$ $= 0.4 \text{ min} = 24 \text{ s}$

The distances and the times found in Example 1 show strikingly how different 10^3 cycles and 10^6 cycles can be.

Finite Life. For cycles less than ($N = 10^6$) the test specimen has a finite life. For most materials the fatigue strength data falls on two straight lines, one from ($N = 1$) to ($N = 10^3$) cycles, and one from ($N = 10^3$) cycles to ($N = 10^6$) cycles.

The equation of the straight line from ($N = 1$) where the fatigue strength (S_f) is the ultimate tensile strength (S_{ut}) to the knee at ($N = 10^3$) cycles has the form

$$S_f = S_{ut} N^{-0.01525} \tag{7.2}$$

where the fatigue strength (S_f) has the value ($0.9 S_{ut}$) at ($N = 10^3$) cycles.

The equation of the straight line from the knee at ($N = 10^3$) cycles where the fatigue strength (S_f) is ($0.9 S_{ut}$) to the knee at ($N = 10^6$) cycles where the fatigue strength (S_f) is (S_e) has the form in Eq. (7.3)

$$S_f = a N^b \tag{7.3}$$

where the coefficient (a) has units of stress and is given by Eq. (7.4)

$$a = \frac{(0.9 S_{ut})^2}{S_e} \tag{7.4}$$

and the exponent (b) is dimensionless and given by Eq. (7.5)

$$b = -\frac{1}{3} \log \frac{0.9 S_{ut}}{S_e} \tag{7.5}$$

If the amplitude stress (σ_a) is known, then substitute this value in Eq. (7.5) and solve for the number of cycles (N), which is given in Eq. (7.6) as

$$N = \left(\frac{\sigma_a}{a}\right)^{1/b} \tag{7.6}$$

Consider the following example using the above equations for finite life.

U.S. Customary	SI/Metric
<p>Example 2. Estimate the following design information for a machine element made of a particular steel:</p> <p>a. Rotating-beam endurance limit (S'_e)</p> <p>b. Fatigue strength (S_f) at 10^5 cycles</p> <p>c. Expected life for a stress level of 60 kpsi</p> <p>where S_{ut} is 90 kpsi and S_y is 70 kpsi.</p> <p>solution</p> <p><i>Step 1.</i> Using the guidelines in Eq. (7.1) where the ultimate tensile strength (S_{ut}) is less than 100 kpsi, the rotating-beam endurance limit (S'_e) is</p> $S'_e = 0.504 S_{ut} = 0.504 (90 \text{ kpsi})$ $= 45.4 \text{ kpsi}$ <p><i>Step 2.</i> Using Eq. (7.4), calculate the coefficient (a) as</p> $a = \frac{(0.9 S_{ut})^2}{S_e} = \frac{(0.9 (90 \text{ kpsi}))^2}{45.4 \text{ kpsi}}$ $= \frac{6,561 \text{ kpsi}^2}{45.4 \text{ kpsi}} = 144.5 \text{ kpsi}$	<p>Example 2. Estimate the following design information for a machine element made of a particular steel:</p> <p>a. Rotating-beam endurance limit (S'_e)</p> <p>b. Fatigue strength (S_f) at 10^5 cycles</p> <p>c. Expected life for a stress level of 420 MPa</p> <p>where S_{ut} is 630 MPa and S_y is 490 MPa.</p> <p>solution</p> <p><i>Step 1.</i> Using the guidelines in Eq. (7.1) where the ultimate tensile strength (S_{ut}) is less than 1400 MPa, the rotating-beam endurance limit (S'_e) is</p> $S'_e = 0.504 S_{ut} = 0.504 (630 \text{ MPa})$ $= 317.5 \text{ MPa}$ <p><i>Step 2.</i> Using Eq. (7.4), calculate the coefficient (a) as</p> $a = \frac{(0.9 S_{ut})^2}{S_e} = \frac{(0.9 (630 \text{ MPa}))^2}{317.5 \text{ MPa}}$ $= \frac{321,489 \text{ MPa}^2}{317.5 \text{ MPa}} = 1,013 \text{ MPa}$

U.S. Customary	SI/Metric
<p><i>Step 3.</i> Using Eq. (7.5), calculate the exponent (<i>b</i>) as</p> $b = -\frac{1}{3} \log \frac{0.9 S_{ut}}{S_e}$ $= -\frac{1}{3} \log \frac{0.9 (90 \text{ kpsi})}{45.4 \text{ kpsi}}$ $= -\frac{1}{3} \log (1.784) = -0.084$ <p><i>Step 4.</i> Using Eq. (7.3), calculate the fatigue strength (S_f) as</p> $S_f = aN^b = (144.5 \text{ kpsi}) (10)^{(5)(-0.084)}$ $= (144.5 \text{ kpsi}) (0.38)$ $= 54.9 \text{ kpsi}$ <p>which is greater than the rotating-beam endurance limit (S'_e) but less than the yield strength (S_y).</p> $\begin{matrix} S'_e \leq S_f \leq S_y \\ 45.4 \leq 54.9 \leq 70 \end{matrix}$ <p><i>Step 5.</i> Using Eq. (7.6), calculate the expected life (N) for the given amplitude stress (σ_a) of 60 kpsi as</p> $N = \left(\frac{\sigma_a}{a}\right)^{1/b} = \left(\frac{60 \text{ kpsi}}{144.5 \text{ kpsi}}\right)^{1/(-0.084)}$ $= (0.4152)^{-11.9} = 35,014 \text{ cycles}$	<p><i>Step 3.</i> Using Eq. (7.5), calculate the exponent (<i>b</i>) as</p> $b = -\frac{1}{3} \log \frac{0.9 S_{ut}}{S_e}$ $= -\frac{1}{3} \log \frac{0.9 (630 \text{ MPa})}{317.5 \text{ MPa}}$ $= -\frac{1}{3} \log (1.786) = -0.084$ <p><i>Step 4.</i> Using Eq. (7.3), calculate the fatigue strength (S_f) as</p> $S_f = aN^b = (1,013 \text{ MPa}) (10)^{(5)(-0.084)}$ $= (1,013 \text{ MPa}) (0.38)$ $= 384.9 \text{ MPa}$ <p>which is greater than the rotating-beam endurance limit (S'_e) but less than the yield strength (S_y).</p> $\begin{matrix} S'_e \leq S_f \leq S_y \\ 317.5 \leq 384.9 \leq 490 \end{matrix}$ <p><i>Step 5.</i> Using Eq. (7.6), calculate the expected life (N) for the given amplitude stress (σ_a) of 420 MPa as</p> $N = \left(\frac{\sigma_a}{a}\right)^{1/b} = \left(\frac{420 \text{ MPa}}{1,013 \text{ MPa}}\right)^{1/(-0.084)}$ $= (0.4146)^{-11.9} = 35,637 \text{ cycles}$

7.3 MARIN EQUATION

The endurance limit (S'_e) determined using the guidelines in Eq. (7.1) that were established from fatigue tests on a standard test specimen must be modified for factors that will usually be different for an actual machine element. These factors account for differences in surface finish, size, load type, temperature, and other miscellaneous effects that may differ from those for the test specimen.

The mathematical model commonly used to apply these factors is credited to Joseph Marin (1962) and is given in Eq. (7.7) as

$$S_e = k_a k_b k_c k_d k_e S'_e \quad (7.7)$$

where S_e = endurance limit for machine element under investigation

S'_e = endurance limit obtained from guidelines in Eq. (7.1)

k_a = surface finish factor

k_b = size factor

k_c = load type factor

k_d = temperature factor

k_e = miscellaneous effects factor

Each of these five factors will be discussed separately, then an example will be presented to pull them together to provide an estimate of the endurance limit (S_e) for a particular machine element design.

The first factor to discuss is the surface finish factor (k_a), probably the most important of the five factors.

Surface Finish Factor. The surface finish of the R. R. Moore rotating-beam machine test specimen is highly polished, particularly to remove any circumferential scratches or marks that would cause premature failure and thereby corrupt the data. The actual machine element under investigation may have a relatively rough surface finish, thereby providing a place for a crack to develop, eventually leading to a fatigue failure.

The surface finish factor (k_a), therefore, depends on the level of smoothness of the surface and the ultimate tensile strength (S_{ut}) and is given in Eq. (7.8) as

$$k_a = aS_{ut}^b \quad (7.8)$$

where the coefficient (a) has units of stress and the exponent (b), which is negative and dimensionless, are found in Table 7.1.

TABLE 7.1 Surface Finish Factors

Surface finish	Factor (a)		Exponent (b)
	kpsi	Mpa	
Ground	1.34	1.58	- 0.085
Machined	2.70	4.51	- 0.265
Cold-drawn	2.70	4.51	- 0.265
Hot-rolled	14.4	57.7	- 0.718
As forged	39.9	272	- 0.995

Notice that as the finish becomes less polished, the coefficient (a) and exponent (b) increase accordingly. It is interesting to compare the surface finish factor for two very different finishes and two different ultimate tensile strengths as shown in the following summary.

Ultimate Tensile Strength (S_{ut})			
Surface finish	kpsi	Mpa	Surface factor (k_a)
Machined	65	455	0.89
As forged	65	455	0.63
Machined	125	875	0.75
As forged	125	875	0.33

Notice that for the lower ultimate tensile strength (S_{ut}) and a machined surface, the reduction is just over 10 percent. However, for the higher ultimate tensile stress and an *as forged* surface, the reduction is over 65 percent. This is why surface finish is so important.

Size Factor. As seen in Fig. 7.4, the R. R. Moore rotating-beam machine test specimen is somewhat small compared to most machine elements. Therefore, the size factor (k_b) accounts for the difference between the machine element and the test specimen.

For axial loading, the size factor (k_b) is not an issue, so use the following value:

$$k_b = 1 \quad (7.9)$$

For bending or torsion, use the following relationships for the range of sizes indicated in Eq. (7.10).

$$k_b = \begin{cases} \left(\frac{d}{0.3}\right)^{-0.1133} & 0.11 \text{ in} \leq d \leq 2 \text{ in} \\ \left(\frac{d}{7.62}\right)^{-0.1133} & 2.79 \text{ mm} \leq d \leq 51 \text{ mm} \end{cases} \quad (7.10)$$

For bending and torsion of larger sizes, the size factor (k_b) varies between 0.60 and 0.75.

For machine elements that are round but not rotating, or shapes that are not round, an *effective diameter*, denoted (d_e), must be used in Eq. (7.10). For a nonrotating round or hollow cross section, the effective diameter (d_e) is given in Eq. (7.11) as

$$d_e = 0.370 D \quad (7.11)$$

where the diameter (D) is the outside diameter of either the solid or hollow cross section.

For a rectangular cross section ($b \times h$), the effective diameter (d_e) is given in Eq. (7.12) as

$$d_e = 0.808 (bh)^{1/2} \quad (7.12)$$

Consider the following example using the above size factor (k_b) equations.

U.S. Customary	SI/Metric
<p>Example 1. Compare the size factor (k_b) for a 2-in diameter solid shaft in torsion to a 2-in diameter but hollow nonrotating shaft.</p> <p>solution</p> <p><i>Step 1.</i> Using Eq. (7.10) calculate the size factor (k_b) as</p> $k_b = \left(\frac{d}{0.3}\right)^{-0.1133} = \left(\frac{2}{0.3}\right)^{-0.1133} = (6.67)^{-0.1133} = 0.81$ <p><i>Step 2.</i> Using Eq. (7.11), calculate the effective diameter (d_e) as</p> $d_e = 0.370 D = 0.370 (2 \text{ in}) = 0.74 \text{ in}$ <p><i>Step 3.</i> Using the effective diameter (d_e) from step 2 in Eq. (7.10) gives the size factor (k_b) for the hollow cross section as</p> $k_b = \left(\frac{d}{0.3}\right)^{-0.1133} = \left(\frac{0.74}{0.3}\right)^{-0.1133} = (2.47)^{-0.1133} = 0.90$ <p>Notice that there is almost a 10 percent difference between these two size factors.</p>	<p>Example 1. Compare the size factor (k_b) for a 51-mm diameter solid shaft in torsion to a 51-mm diameter but hollow nonrotating shaft.</p> <p>solution</p> <p><i>Step 1.</i> Using Eq. (7.10) calculate the size factor (k_b) as</p> $k_b = \left(\frac{d}{7.62}\right)^{-0.1133} = \left(\frac{51}{7.62}\right)^{-0.1133} = (6.69)^{-0.1133} = 0.81$ <p><i>Step 2.</i> Using Eq. (7.11), calculate the effective diameter (d_e) as</p> $d_e = 0.370 D = 0.370 (51 \text{ mm}) = 18.87 \text{ mm}$ <p><i>Step 3.</i> Using the effective diameter (d_e) from step 2 in Eq. (7.10) gives the size factor (k_b) for the hollow cross section as</p> $k_b = \left(\frac{d}{7.62}\right)^{-0.1133} = \left(\frac{18.87}{7.62}\right)^{-0.1133} = (2.48)^{-0.1133} = 0.90$ <p>Notice that there is almost a 10 percent difference between these two size factors.</p>

Load Type Factor. The load type factor (k_c) for axial loading is given in Eq. (7.13) as

$$\begin{aligned} \text{U.S. Customary: } k_c &= \begin{cases} 0.923 & S_{ut} \leq 220 \text{ kpsi} \\ 1 & S_{ut} > 220 \text{ kpsi} \end{cases} \\ \text{SI/metric: } k_c &= \begin{cases} 0.923 & S_{ut} \leq 1,540 \text{ MPa} \\ 1 & S_{ut} > 1,540 \text{ MPa} \end{cases} \end{aligned} \quad (7.13)$$

For bending, torsion, or shear, the load type factor (k_c) is given in Eq. (7.14) as

$$k_c = \begin{cases} 1 & \text{bending} \\ 0.577 & \text{torsion and shear} \end{cases} \quad (7.14)$$

where the value for torsion and shear is related to the distortion-energy theory for determining whether a design is safe under static loading conditions.

Temperature Factor. For temperatures very much lower than room temperature materials like ductile steel become brittle. Materials like aluminum seem to be unaffected by similar low temperatures.

The temperature factor (k_d) is given in Eq. (7.15) as

$$k_d = \frac{S_T}{S_{RT}} \quad (7.15)$$

where (S_T) is the ultimate tensile strength at some specific temperature (T) and (S_{RT}) is the ultimate tensile strength at room temperature (RT). Values of the ratio (S_T/S_{RT}), which is actually the temperature factor (k_d), are given in Table 7.2.

TABLE 7.2 Temperature Factors

°F	k_d	°C	k_d
70	1.000	20	1.000
100	1.008	50	1.010
200	1.020	100	1.020
300	1.024	150	1.025
400	1.018	200	1.020
500	0.995	250	1.000
600	0.963	300	0.975
700	0.927	350	0.927
800	0.872	400	0.922
900	0.797	450	0.840
1000	0.698	500	0.766
1100	0.567	550	0.670

Notice that the temperature factor (k_d) initially increases as the temperature increases, then begins to decrease as the temperature continues to increase. The temperature of most materials can reach values that induce creep and yielding becomes more important than fatigue.

Miscellaneous Effects Factor. All the following effects are important in the dynamic loading of machine elements, however, only one can be quantified. These effects are residual

stresses, corrosion, electrolytic plating, metal spraying, cyclic frequency, fretage corrosion, and stress concentration.

Residual stresses can improve the endurance limit if they increase the compressive stresses, especially at the surface through such processes as shot peening and most cold working. However, residual stresses that increase the tensile stresses, again especially at the surface, tend to reduce the endurance limit.

Corrosion tends to reduce the endurance limit as it produces imperfections at the surface of the machine element where the small cracks associated with fatigue failure can develop.

Electrolytic plating such as chromium or cadmium plating can reduce the endurance limit by as much as 50 percent.

Like corrosion, metal spraying produces imperfections at the surface so it tends to reduce the endurance limit.

Cyclic frequency is usually not important, unless the temperature is relatively high and there is the presence of corrosion. The lower the frequency of the repeated reversed loading and the higher the temperature, the faster the propagation of cracks once they develop, and therefore, the shorter the fatigue life of the machine element.

Fretage is a type of corrosion where very tightly fitted parts (bolted and riveted joints, press or fits between gears, pulleys, and shafts, and bearing races in close tolerance seats) move ever so slightly producing pitting and discoloration similar to normal corrosion. The result is a reduced fatigue life because small cracks can develop in these microscopic areas. Depending on the material, fretage corrosion can reduce the fatigue life from 10 to 80 percent, so it is an important issue to consider.

Stress concentration is the only miscellaneous effect that can be accurately quantified. In Chap. 6, Sec. 6.1.3, a *reduced* stress concentration factor (K_f) needed to be applied to the design of brittle materials. As fatigue failure is similar to brittle failure, stress concentrations need to be considered for both ductile and brittle materials under repeated loadings, whether they are completely reversed or fluctuating. The reduced stress concentration factor (K_f) was determined from Eq. (6.23), repeated here.

$$K_f = 1 + q(K_t - 1) \quad (6.23)$$

where the geometric stress concentration factor (K_t) is modified or *reduced* due to any notch sensitivity (q) of the material. Values for the stress concentration factor (K_t) for various types of geometric discontinuities are given in any number of references (Marks). Charts for the notch sensitivity (q) are also given in these references.

The miscellaneous effects factor for stress concentration (k_e) is therefore the reciprocal of the reduced stress concentration factor (K_f) and given in Eq. (7.16) as

$$k_e = \frac{1}{K_f} \quad (7.16)$$

where as (K_f) is usually greater than one, the miscellaneous effects factor (k_e) will be less than 1 and thereby reduce the test specimen endurance limit (S'_e) accordingly.

Note that the miscellaneous effects factor (k_e) for stress concentration applies to the endurance limit (S'_e) at ($N = 10^6$) and greater. However, below ($N = 10^3$) cycles it has no effect, meaning ($K_f = 1$) or ($k_e = 1$). Similar to the process for finite life, between ($N = 10^3$) and ($N = 10^6$) cycles define a modified stress concentration factor (K'_f) where

$$K'_f = aN^b \quad (7.17)$$

and the coefficients (a) and (b), both dimensionless, are given in Eq. (7.18) as

$$a = \frac{1}{K_f} \quad \text{and} \quad b = -\frac{1}{3} \log \frac{1}{K_f} \quad (7.18)$$

where the reduced stress concentration factor (K_f) is found from Eq. (6.23).

Consider the following example that brings together all the modifying factors in the Marin equation for a particular machine element.

U.S. Customary	SI/Metric
<p>Example 2. Determine the endurance limit (S_e) using the Marin equation for a 1.0-in diameter machined shaft with a transverse hole under reversed bending at room temperature, where</p> <p>$S_{ut} = 120$ kpsi $S_y = 80$ kpsi $K_t = 2.15$ (0.125-in transverse hole) $q = 0.8$ (notch sensitivity)</p> <p>solution</p> <p><i>Step 1.</i> Using Eq. (7.8) and values for the coefficient (a) and exponent (b) from Table 7.1, calculate the surface finish factor (k_a) as</p> $k_a = aS_{ut}^b$ $= (2.70 \text{ kpsi}) (120 \text{ kpsi})^{-0.265}$ $= (2.70) (0.2812)$ $= 0.76$ <p><i>Step 2.</i> Using Eq. (7.10) calculate the size factor (k_b) as</p> $k_b = \left(\frac{d}{0.3}\right)^{-0.1133} = \left(\frac{1}{0.3}\right)^{-0.1133}$ $= (3.33)^{-0.1133} = 0.87$ <p><i>Step 3.</i> As the shaft is bending, the load type factor (k_c) from Eq. (7.14) is</p> $k_c = 1$ <p><i>Step 4.</i> As the shaft is operating at room temperature, the temperature factor (k_d) from Eq. (7.15) and Table 7.2 is</p> $k_d = 1$	<p>Example 2. Determine the endurance limit (S_e) using the Marin equation for a 25-mm diameter machined shaft with a transverse hole under reversed bending at room temperature, where</p> <p>$S_{ut} = 840$ MPa $S_y = 560$ MPa $K_t = 2.15$ (3.2-mm transverse hole) $q = 0.8$ (notch sensitivity)</p> <p>solution</p> <p><i>Step 1.</i> Using Eq. (7.8) and values for the coefficient (a) and exponent (b) from Table 7.1, calculate the surface finish factor (k_a) as</p> $k_a = aS_{ut}^b$ $= (4.51 \text{ MPa}) (840 \text{ MPa})^{-0.265}$ $= (4.51) (0.1679)$ $= 0.76$ <p><i>Step 2.</i> Using Eq. (7.10) calculate the size factor (k_b) as</p> $k_b = \left(\frac{d}{7.62}\right)^{-0.1133} = \left(\frac{25}{7.62}\right)^{-0.1133}$ $= (3.28)^{-0.1133} = 0.87$ <p><i>Step 3.</i> As the shaft is bending, the load type factor (k_c) from Eq. (7.14) is</p> $k_c = 1$ <p><i>Step 4.</i> As the shaft is operating at room temperature, the temperature factor (k_d) from Eq. (7.15) and Table 7.2 is</p> $k_d = 1$

U.S. Customary	SI/Metric
<p><i>Step 5.</i> Using Eq. (6.23), along with the given values for the geometric stress concentration factor (K_t) and notch sensitivity (q), calculate the reduced stress concentration factor (K_f) as</p> $K_f = 1 + q(K_t - 1) = 1 + (0.8)(2.15 - 1)$ $= 1 + 0.92 = 1.92$ <p><i>Step 6.</i> Using the reduced stress concentration factor (K_f) found in step 5, calculate the miscellaneous effects factor (k_e) using Eq. (7.16) as</p> $k_e = \frac{1}{K_f} = \frac{1}{1.92} = 0.52$ <p><i>Step 7.</i> Using the given ultimate tensile stress (S_{ut}) and Eq. (7.1), calculate the test specimen endurance limit (S'_e) as</p> $S'_e = 0.504 S_{ut} = (0.504)(120 \text{ kpsi})$ $= 60.5 \text{ kpsi}$ <p><i>Step 8.</i> Using the test specimen endurance limit (S'_e) found in step 7 and the modifying factors found in steps 1 through 6, calculate the endurance limit (S_e) for the machine element using the Marin equation in Eq. (7.7) as</p> $S_e = k_a k_b k_c k_d k_e S'_e$ $= (0.76)(0.87)(1)(1)(0.52)(60.5 \text{ kpsi})$ $= (0.344)(60.5 \text{ kpsi}) = 20.8 \text{ kpsi}$	<p><i>Step 5.</i> Using Eq. (6.23), along with the given values for the geometric stress concentration factor (K_t) and notch sensitivity (q), calculate the reduced stress concentration factor (K_f) as</p> $K_f = 1 + q(K_t - 1) = 1 + (0.8)(2.15 - 1)$ $= 1 + 0.92 = 1.92$ <p><i>Step 6.</i> Using the reduced stress concentration factor (K_f) found in step 5, calculate the miscellaneous effects factor (k_e) using Eq. (7.16) as</p> $k_e = \frac{1}{K_f} = \frac{1}{1.92} = 0.52$ <p><i>Step 7.</i> Using the given ultimate tensile stress (S_{ut}) and Eq. (7.1), calculate the test specimen endurance limit (S'_e) as</p> $S'_e = 0.504 S_{ut} = (0.504)(840 \text{ MPa})$ $= 423.4 \text{ MPa}$ <p><i>Step 8.</i> Using the test specimen endurance limit (S'_e) found in step 7 and the modifying factors found in steps 1 through 6, calculate the endurance limit (S_e) for the machine element using the Marin equation in Eq. (7.7) as</p> $S_e = k_a k_b k_c k_d k_e S'_e$ $= (0.76)(0.87)(1)(1)(0.52)(423.4 \text{ MPa})$ $= (0.344)(423.4 \text{ MPa}) = 145.6 \text{ MPa}$

Notice that the biggest reduction, almost 50 percent, in the endurance limit (S_e) for the machine element came from the stress concentration caused by the transverse hole in the shaft. Accounting for all five factors reduced the endurance limit (S_e) to one-third the test specimen endurance limit (S'_e) found from the R. R. Moore rotating-beam machine. This translates into a minimum factor-of-safety ($n = 3$) to have a safe design under repeated reversed loading. Again, this is why the first law of machine design is "When in doubt, make it stout!"

Consider now the possibility that the dynamic loading is fluctuating rather than being completely reversed as has been the assumption so far.

7.4 FLUCTUATING LOADING

The second type of dynamic loading to be presented is called fluctuating loading, where the load on the machine element varies about some mean stress (σ_m), which can be positive or negative, by an amount called the alternating stress (σ_a). Note that if the

mean stress is zero, then the loading is completely reversed as presented in the previous section.

Although fluctuating loading, like reversed loading, can be represented by a square wave, saw tooth wave, sinusoidal wave, or some other wave form as long as it has a constant period, the remainder of the discussion in this section assumes a sinusoidal wave form like that shown in Fig. 7.6.

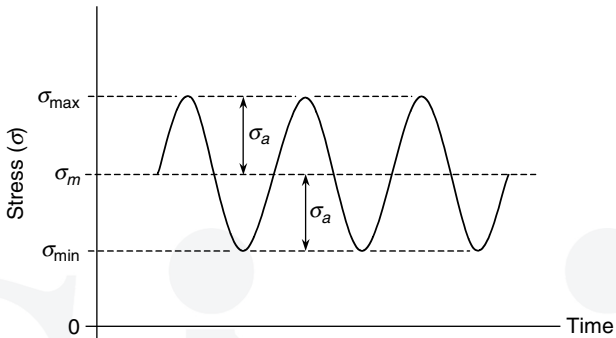

FIGURE 7.6 Fluctuating loading (positive stresses).

In Fig. 7.6, the mean stress (σ_m) has been shown positive and the alternating stress (σ_a) has a magnitude such that the maximum stress (σ_{max}) and the minimum stress (σ_{min}) are also positive. However, a second possibility is for the mean stress (σ_m) to be positive and the alternating stress (σ_a) having a magnitude such that the maximum stress (σ_{max}) is still positive; whereas the minimum stress (σ_{min}) becomes negative as shown in Fig. 7.7.

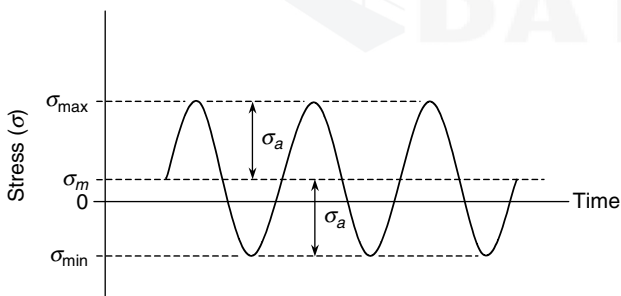

FIGURE 7.7 Fluctuating loading (positive and negative stresses).

The third possibility is that the mean stress (σ_m) is negative and the alternating stress (σ_a) has a magnitude such that the maximum stress (σ_{max}) and the minimum stress (σ_{min}) are also negative, as shown in Fig. 7.8.

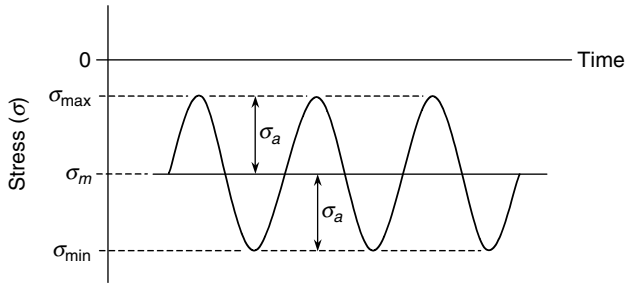

FIGURE 7.8 Fluctuating loading (negative stresses).

For any of the these three possibilities, the mean stress (σ_m) and the alternating stress (σ_a) can be related to the maximum stress (σ_{max}) and the minimum stress (σ_{min}) by the following relationships:

$$\sigma_m = \frac{\sigma_{max} + \sigma_{min}}{2} \tag{7.19}$$

$$\sigma_a = \frac{\sigma_{max} - \sigma_{min}}{2} \tag{7.20}$$

Design Criteria. Data from fatigue tests with fluctuating loading can be plotted in a diagram where the horizontal axis is the ratio of the mean strength (S_m) to either the ultimate tensile strength (S_{ut}) or the ultimate compressive strength (S_{uc}) and the vertical axis is the ratio of the alternating strength (S_a) to the endurance limit (S_e). Such a diagram is shown in Fig. 7.9, where the test data (not shown) fall close to the horizontal line in the compressive region and close to the 45° line in the tensile region.

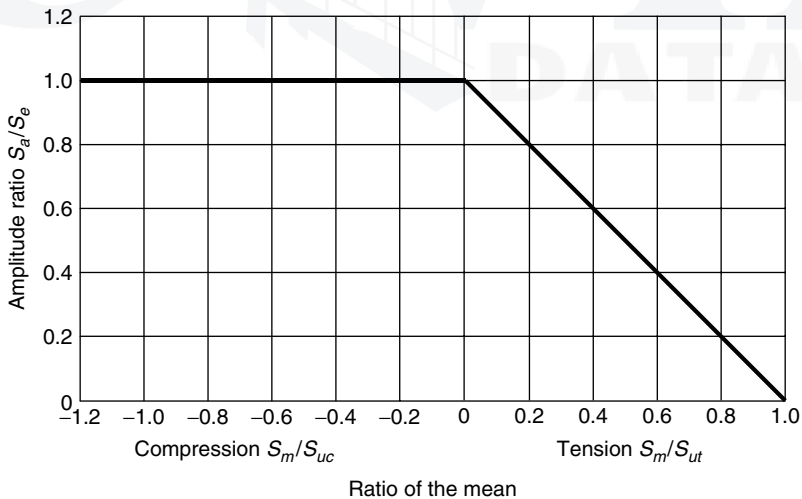

FIGURE 7.9 Plot of test data for fluctuating loading.

It is clear that if the mean stress (σ_m) is compressive, then the design is safe if the alternating stress (σ_a) is less than the endurance limit (S_e), as long as the maximum stress (σ_{\max}) is less than the compressive yield strength (S_{yc}). These two conditions can be seen graphically to the left of the vertical axis in Fig. 7.10, where the horizontal line represents the first condition, ($\sigma_a < S_e$) and the 45° line represents the second ($\sigma_{\max} < S_{yc}$).

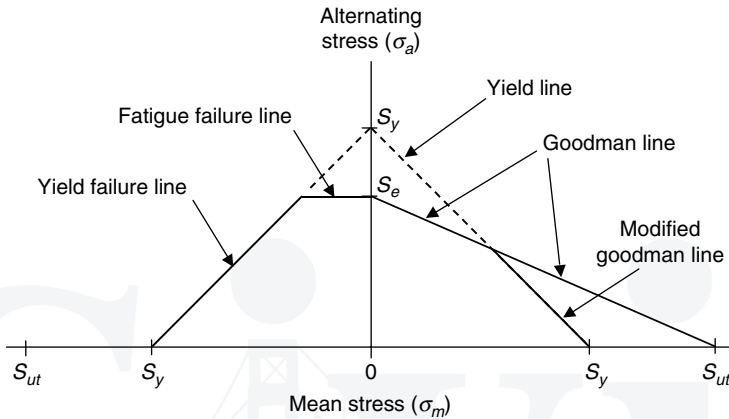

FIGURE 7.10 Goodman theory and modified Goodman theory.

The line connecting the endurance limit (S_e) with the ultimate tensile strength (S_{ut}) in Fig. 7.10 represents the Goodman theory, suggested by the line at 45° on the tensile side of Fig. 7.9. The modified Goodman theory moves the boundary on the tensile side for safe designs so as not to exceed the yield strength (S_y). In fact, in many references the two lines on the left side of the vertical axis in Fig. 7.10, the one that is horizontal and the one at a 45° angle, are also included in the modified Goodman theory because both are suggested by the data summarized in Fig. 7.9 and both represent boundaries for both fatigue and yield stress failures. The remaining discussion on the design criteria for fluctuating loading need only consider a positive mean stress (σ_m).

There are three theories that are commonly used to predict whether a design is safe under fluctuating loading: (1) the Goodman theory, (2) the Soderberg theory, and (3) the Gerber theory. All three can be expressed mathematically; however a graphical representation is considered very useful. The Goodman theory is probably the most used by designers; however, the other two are important enough to be discussed as well.

These three theories are shown as lines in the diagram in Fig. 7.11, where the horizontal axis is the mean stress (σ_m) and the vertical axis is the alternating stress (σ_a).

Note that the endurance limit (S_e) plotted on the vertical axis is assumed to have already been modified according to the Marin equation. Also, the yield strength (S_y) has been plotted on both the horizontal and vertical axes and a *yield line* drawn to make sure this design limitation is not omitted.

From Fig. 7.11, several important points can be made. First, the Soderberg theory is the most conservative of the three shown, and is the only one that is completely below the yield line. Secondly, the Gerber line fits the available test data the best of the three theories; however, it is the most difficult to draw accurately.

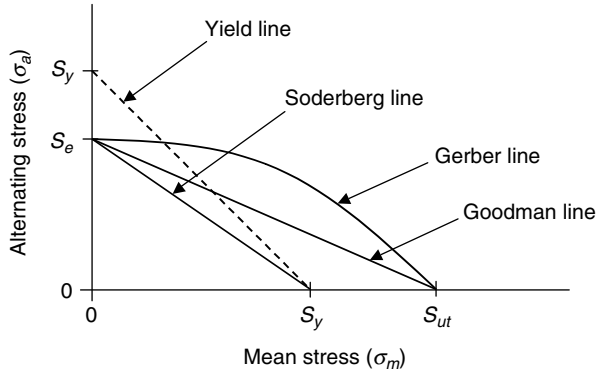

FIGURE 7.11 Goodman, Soderberg, and Gerber lines.

The mathematical expression for the Soderberg theory is given in Eq. (7.21),

$$\frac{S_a}{S_e} + \frac{S_m}{S_y} = 1 \tag{7.21}$$

the mathematical expression for the Goodman theory is given in Eq. (7.22),

$$\frac{S_a}{S_e} + \frac{S_m}{S_{ut}} = 1 \tag{7.22}$$

and the mathematical expression for the Gerber theory is given in Eq. (7.23),

$$\frac{S_a}{S_e} + \left(\frac{S_m}{S_{ut}}\right)^2 = 1 \tag{7.23}$$

where (S_m) is the mean strength and (S_a) is the alternating strength.

Factors-of-safety (n) can be established for each of these three theories by substituting the actual mean stress (σ_m) for the mean strength (S_m), substituting the actual alternating stress (σ_a) for the alternating strength (S_a), and substituting $(1/n)$ for 1.

For the Soderberg theory the factor-of-safety (n) is found from Eq. (7.24),

$$\frac{\sigma_a}{S_e} + \frac{\sigma_m}{S_y} = \frac{1}{n} \tag{7.24}$$

for the Goodman theory the factor-of-safety (n) is found from Eq. (7.25),

$$\frac{\sigma_a}{S_e} + \frac{\sigma_m}{S_{ut}} = \frac{1}{n} \tag{7.25}$$

and for the Gerber theory the factor-of-safety is found from Eq. (7.26),

$$\frac{n\sigma_a}{S_e} + \left(\frac{n\sigma_m}{S_{ut}}\right)^2 = 1 \tag{7.26}$$

As the Goodman theory is the most commonly used, it is shown by itself in Fig. 7.12 where the mean stress (σ_m) and alternating stress (σ_a) are plotted.

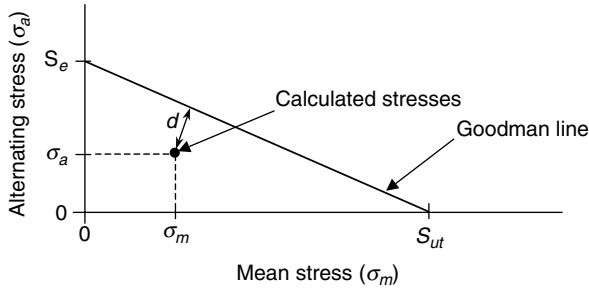

FIGURE 7.12 Graphical approach using the Goodman theory.

The point with coordinates (σ_m, σ_a) is shown inside the Goodman line, therefore the perpendicular distance (d) from this point to the Goodman line represents graphically the factor-of-safety (n) of the design. If this point had been outside the Goodman line, then the design is not safe.

Sometimes the factor-of-safety (n) is desired where either the mean stress (σ_m) or the alternating stress (σ_a) is held constant. For the case where the mean stress (σ_m) is held constant, the factor-of-safety (n_m) is represented by a vertical distance from the point (σ_m, σ_a) to the Goodman line. This is shown as the distance (d_m) in Fig. 7.13. The corresponding alternating stress is denoted by $(\sigma_a|_{\sigma_m})$ forming a right triangle with the endurance limit (S_e).

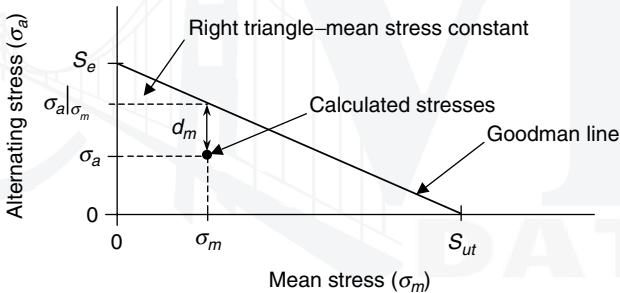

FIGURE 7.13 Factor-of-safety (n_m) holding the mean stress constant.

The factor-of-safety (n_m) is therefore the ratio

$$n_m = \frac{\sigma_a|_{\sigma_m}}{\sigma_a} \tag{7.27}$$

whereby in similar triangles, the alternating stress $(\sigma_a|_{\sigma_m})$ can be found from Eq. (7.28) as

$$\sigma_a|_{\sigma_m} = S_e \left(1 - \frac{\sigma_m}{S_{ut}} \right) \tag{7.28}$$

The alternating stress $(\sigma_a|_{\sigma_m})$ can also be found graphically if all the information is plotted to scale in a diagram similar to Fig. 7.13, as will be done shortly in an example.

For the case where the alternating stress (σ_a) is held constant, the factor-of-safety (n_a) is represented by a horizontal line from the point (σ_m, σ_a) to the Goodman line. This is shown as the distance (d_a) in Fig. 7.14. The corresponding mean stress is denoted as $(\sigma_m|_{\sigma_a})$ forming a right triangle with the ultimate tensile strength (S_{ut}).

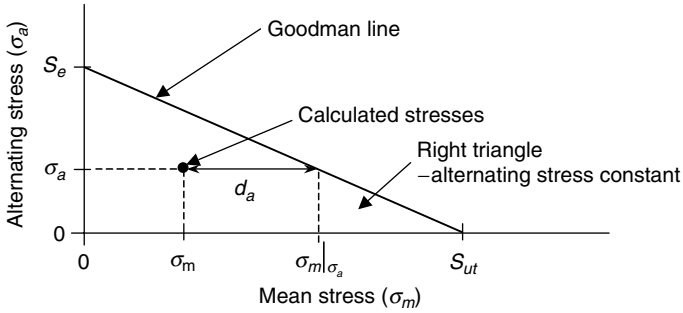

FIGURE 7.14 Factor-of-safety (n_a) holding the alternating stress constant.

The factor-of-safety (n_a) is therefore the ratio

$$n_a = \frac{\sigma_m | \sigma_a}{\sigma_m} \tag{7.29}$$

whereby in similar triangles, the mean stress ($\sigma_m | \sigma_a$) can be found from Eq. (7.30) as

$$\sigma_m | \sigma_a = S_{ut} \left(1 - \frac{\sigma_a}{S_e} \right) \tag{7.30}$$

The mean stress ($\sigma_m | \sigma_a$) can also be found graphically if all the information is plotted to scale in a diagram similar to Fig. 7.14, as will be done shortly in an example.

There is a third possibility where the line connecting the origin of the coordinate system to the point (σ_m, σ_a) is extended to the Goodman line. This means that the ratio of the alternating stress (σ_a) to the mean stress (σ_m) is held constant. This line may or may not intersect the Goodman line at a right angle. The factor-of-safety (n_c) is represented by the distance (d_c) in Fig. 7.15. The corresponding mean stress ($\sigma_m | c$), alternating stress ($\sigma_a | c$), and endurance limit (S_e) form a right triangle as shown.

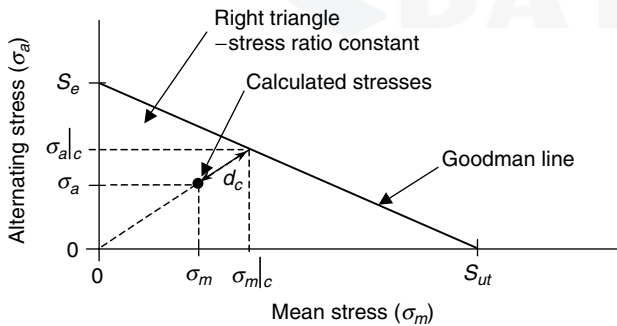

FIGURE 7.15 Factor-of-safety (n_c) holding the alternating stress constant.

The factor-of-safety (n_c) is either of the two ratios in Eq. (7.31); however, the first is preferred.

$$n_c = \frac{\sigma_m | c}{\sigma_m} = \frac{\sigma_a | c}{\sigma_a} \tag{7.31}$$

By similar triangles, the mean stress ($\sigma_m|_c$) can be found from Eq. (7.32) as

$$\sigma_m|_c = \frac{S_e}{\frac{S_e}{S_{ut}} + \frac{\sigma_a}{\sigma_m}} \quad (7.32)$$

The mean stress ($\sigma_m|_c$), or the alternating stress ($\sigma_a|_c$), can also be found graphically if all the information is plotted to scale in a diagram similar to Fig. 7.15, as will be done shortly in an example.

Remember, the factor-of-safety (n) associated with the perpendicular distance (d) from the point (σ_m, σ_a) to the Goodman line is given by Eq. (7.25), or it too can be found graphically by plotting all the information in a diagram similar to Fig. 7.12.

The following examples, in both the U.S. Customary and SI/metric system of units, will use both the mathematical expressions presented on the previous pages, as well as a graphical approach, to determine the various factors-of-safety for a particular design.

U.S. Customary

Example 1. For the cantilevered beam shown in Fig. 7.16, which is acted upon by a fluctuating tip force (F) of between 2.4 lb and 5.6 lb, determine

- a. The factor-of-safety (n) using the Goodman theory
- b. The factor-of-safety (n_m) where the mean stress (σ_m) is held constant
- c. The factor-of-safety (n_a) where the alternating stress (σ_a) is held constant
- d. The factor-of-safety (n_c) where the ratio of the alternating stress (σ_a) to the mean stress (σ_m) is held constant



FIGURE 7.16 Cantilevered beam for Example 1 (U.S. Customary).

The beam is made of cold-drawn steel, ground to the dimensions shown, then welded to the vertical support at its left end. The beam operates at room temperature. Also, S_{ut} is 85 kpsi and K_f is 1.2 (due to welds at left end of beam).

solution

Step 1. Using Eq. (7.8) and values for the coefficient (a) and exponent (b) from Table 7.1, calculate the surface finish factor (k_a) as

$$k_a = aS_{ut}^b = (1.34 \text{ kpsi})(85 \text{ kpsi})^{-0.085} = (1.34)(0.6855) = 0.92$$

Step 2. Using Eq. (7.12) calculate the effective diameter (d_e) as

$$\begin{aligned} d_e &= 0.808(bh)^{1/2} = 0.808\sqrt{\left(\frac{1}{16} \text{ in}\right)\left(\frac{1}{2} \text{ in}\right)} = (0.808)\sqrt{(0.03125 \text{ in}^2)} \\ &= (0.808)(0.1768 \text{ in}) = 0.143 \text{ in} \end{aligned}$$

Step 3. Using Eq. (7.10) calculate the size factor (k_b) as

$$k_b = \left(\frac{d_e}{0.3}\right)^{-0.1133} = \left(\frac{0.143}{0.3}\right)^{-0.1133} = (0.477)^{-0.1133} = 1.09 \cong 1$$

Step 4. As the beam is bending, the load type factor (k_c) from Eq. (7.14) is

$$k_c = 1$$

Step 5. As the beam is operating at room temperature, the temperature factor (k_d) from Eq. (7.15) and Table 7.2 is

$$k_d = 1$$

Step 6. Using the given reduced stress concentration factor (K_f), calculate the miscellaneous effect factor (k_e) using Eq. (7.16) as

$$k_e = \frac{1}{K_f} = \frac{1}{1.2} = 0.83$$

Step 7. Using the given ultimate tensile stress (S_{ut}) and the guidelines in Eq. (7.1), calculate the test specimen endurance limit (S'_e) as

$$S'_e = 0.504 S_{ut} = (0.504)(85 \text{ kpsi}) = 42.8 \text{ kpsi}$$

Step 8. Using the test specimen endurance limit (S'_e) found in step 7 and the modifying factors found in steps 1 through 6, calculate the endurance limit (S_e) for the cantilevered beam using the Marin equation in Eq. (7.7) as

$$\begin{aligned} S_e &= k_a k_b k_c k_d k_e S'_e = (0.92)(1)(1)(1)(0.83)(42.8 \text{ kpsi}) \\ &= (0.764)(42.8 \text{ kpsi}) = 32.7 \text{ kpsi} \end{aligned}$$

Step 9. Calculate the mean force (F_m) and the alternating force (F_a) as

$$\begin{aligned} F_m &= \frac{F_{\max} + F_{\min}}{2} = \frac{(5.6 \text{ lb}) + (2.4 \text{ lb})}{2} = \frac{8 \text{ lb}}{2} = 4 \text{ lb} \\ F_a &= \frac{F_{\max} - F_{\min}}{2} = \frac{(5.6 \text{ lb}) - (2.4 \text{ lb})}{2} = \frac{3.2 \text{ lb}}{2} = 1.6 \text{ lb} \end{aligned}$$

Step 10. Calculate the mean bending moment (M_m) and the alternating bending moment (M_a) as

$$\begin{aligned} M_m &= F_m L = (4 \text{ lb})(2.5 \text{ in}) = 10 \text{ in} \cdot \text{lb} \\ M_a &= F_a L = (1.6 \text{ lb})(2.5 \text{ in}) = 4 \text{ in} \cdot \text{lb} \end{aligned}$$

Step 11. Calculate the area moment of inertia (I) for the rectangular cross section as

$$I = \frac{1}{12}bh^3 = \frac{1}{12}(0.5 \text{ in})(0.0625 \text{ in})^3 = 1.02 \times 10^{-5} \text{ in}^4$$

Step 12. Calculate the mean bending stress (σ_m) and the alternating bending stress (σ_a) as

$$\sigma_m = \frac{M_m c}{I} = \frac{(10 \text{ in} \cdot \text{lb})(0.03125 \text{ in})}{1.02 \times 10^{-5} \text{ in}^4} = 30.6 \text{ kpsi}$$

$$\sigma_a = \frac{M_a c}{I} = \frac{(4 \text{ in} \cdot \text{lb})(0.03125 \text{ in})}{1.02 \times 10^{-5} \text{ in}^4} = 12.3 \text{ kpsi}$$

Step 13. Plot the mean bending stress (σ_m) and alternating bending stress (σ_a) from step 12, the given ultimate tensile strength (S_{ut}), and the endurance limit (S_e) calculated in step 8 in a Goodman diagram like that shown in Fig. 7.17.

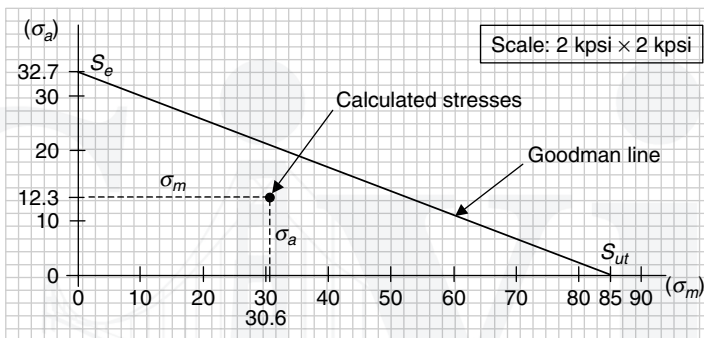

FIGURE 7.17 Goodman diagram for Example 1 (U.S. Customary).

Step 14. To answer question (a), calculate the factor-of-safety (n) using Eq. (7.25), which represents the distance (d) in Fig. 7.12.

$$\frac{1}{n} = \frac{\sigma_a}{S_e} + \frac{\sigma_m}{S_{ut}} = \frac{12.3 \text{ kpsi}}{32.7 \text{ kpsi}} + \frac{30.6 \text{ kpsi}}{85 \text{ kpsi}} = (0.376) + (0.360) = 0.736$$

$$n = \frac{1}{0.736} = 1.36$$

Step 15. To answer question (b), calculate the factor-of-safety (n_m) using Eq. (7.27), which represents the distance (d_m) in Fig. 7.13.

$$\begin{aligned} n_m &= \frac{\sigma_a | \sigma_m}{\sigma_a} = \frac{S_e \left(1 - \frac{\sigma_m}{S_{ut}}\right)}{\sigma_a} = \frac{(32.7 \text{ kpsi}) \left(1 - \frac{30.6 \text{ kpsi}}{85 \text{ kpsi}}\right)}{12.3 \text{ kpsi}} = \frac{(32.7 \text{ kpsi}) (0.640)}{12.3 \text{ kpsi}} \\ &= \frac{20.93 \text{ kpsi}}{12.3 \text{ kpsi}} = 1.70 \end{aligned}$$

where the alternating stress ($\sigma_a | \sigma_m$) was substituted from Eq. (7.28).

Step 16. To answer question (c), calculate the factor-of-safety (n_a) using Eq. (7.29), which represents the distance (d_a) in Fig. 7.14.

$$\begin{aligned} n_a &= \frac{\sigma_m |_{\sigma_a}}{\sigma_m} = \frac{S_{ut} \left(1 - \frac{\sigma_a}{S_e}\right)}{\sigma_m} = \frac{(85 \text{ kpsi}) \left(1 - \frac{12.3 \text{ kpsi}}{32.7 \text{ kpsi}}\right)}{30.6 \text{ kpsi}} = \frac{(85 \text{ kpsi}) (0.624)}{30.6 \text{ kpsi}} \\ &= \frac{53.04 \text{ kpsi}}{30.6 \text{ kpsi}} = 1.73 \end{aligned}$$

where the alternating stress ($\sigma_m |_{\sigma_a}$) was substituted from Eq. (7.30).

Step 17. To answer question (d), calculate the factor-of-safety (n_c) using Eq. (7.31), which represents the distance (d_c) in Fig. 7.15.

$$\begin{aligned} n_c &= \frac{\sigma_m |_c}{\sigma_m} = \frac{\frac{S_e}{\frac{S_{ut}}{S_e} + \frac{\sigma_a}{\sigma_m}}}{\sigma_m} = \frac{S_e}{\sigma_m \left(\frac{S_{ut}}{S_e} + \frac{\sigma_a}{\sigma_m}\right)} \\ &= \frac{32.7 \text{ kpsi}}{(30.6 \text{ kpsi}) \left(\frac{32.7 \text{ kpsi}}{85 \text{ kpsi}} + \frac{12.3 \text{ kpsi}}{30.6 \text{ kpsi}}\right)} = \frac{32.7 \text{ kpsi}}{(30.6 \text{ kpsi})(0.385 + 0.402)} \\ &= \frac{32.7 \text{ kpsi}}{(30.6 \text{ kpsi})(0.787)} = \frac{32.7 \text{ kpsi}}{24.08 \text{ kpsi}} = 1.36 \end{aligned}$$

where the alternating stress ($\sigma_m |_c$) was substituted from Eq. (7.32).

Notice that the factors-of-safety for parts (a) and (d) are the same, and the factors-of-safety for parts (b) and (c) are very close. This is not unexpected. Also, the factors-of-safety for all four parts could have been found graphically by scaling the appropriate distances in Fig. 7.17.

SI/Metric

Example 1. For the cantilevered beam shown in Fig. 7.18, which is acted upon by a fluctuating tip force (F) of between (10.8 N) and (25.2 N), determine

- The factor-of-safety (n) using the Goodman theory
- The factor-of-safety (n_m) where the mean stress (σ_m) is held constant
- The factor-of-safety (n_a) where the alternating stress (σ_a) is held constant
- The factor-of-safety (n_c) where the ratio of the alternating stress (σ_a) to the mean stress (σ_m) is held constant

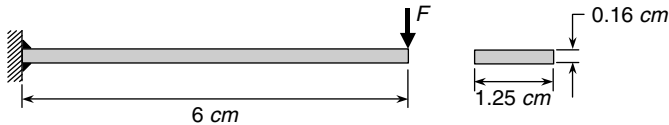

FIGURE 7.18 Cantilevered beam for Example 1 (SI/metric).

The beam is made of cold-drawn steel, ground to the dimensions shown, then welded to the vertical support at its left end. The beam operates at room temperature. Also, S_{ut} is 595 MPa and K_f is 1.2 (due to welds at left end of beam).

solution

Step 1. Using Eq. (7.8) and values for the coefficient (a) and exponent (b) from Table 7.1, calculate the surface finish factor (k_a) as

$$k_a = aS_{ut}^b = (1.58 \text{ MPa}) (595 \text{ MPa})^{-0.085} = (1.58) (0.5810) = 0.92$$

Step 2. Using Eq. (7.12) calculate the effective diameter (d_e) as

$$\begin{aligned} d_e &= 0.808 (bh)^{1/2} = 0.808 \sqrt{(0.16 \text{ cm}) (1.25 \text{ cm})} = (0.808) \sqrt{(0.20 \text{ cm}^2)} \\ &= (0.808) (0.4472 \text{ cm}) = 0.361 \text{ cm} = 3.61 \text{ mm} \end{aligned}$$

Step 3. Using Eq. (7.10) calculate the size factor (k_b) as

$$k_b = \left(\frac{d_e}{7.62} \right)^{-0.1133} = \left(\frac{3.61}{7.62} \right)^{-0.1133} = (0.474)^{-0.1133} = 1.09 \cong 1$$

Step 4. As the beam is in bending the load type factor (k_c) from Eq. (7.14) is

$$k_c = 1$$

Step 5. As the beam is operating at room temperature, the temperature factor (k_d) from Eq. (7.15) and Table 7.2 is

$$k_d = 1$$

Step 6. Using the given reduced stress concentration factor (K_f), calculate the miscellaneous effect factor (k_e) using Eq. (7.16) as

$$k_e = \frac{1}{K_f} = \frac{1}{1.2} = 0.83$$

Step 7. Using the given ultimate tensile stress (S_{ut}) and the guidelines in Eq. (7.1), calculate the test specimen endurance limit (S'_e) as

$$S'_e = 0.504 S_{ut} = (0.504) (595 \text{ MPa}) = 300 \text{ MPa}$$

Step 8. Using the test specimen endurance limit (S'_e) found in Step 7 and the modifying factors found in Steps 1 through 6, calculate the endurance limit (S_e) for the cantilevered beam using the Marin equation in Eq. (7.7) as

$$\begin{aligned} S_e &= k_a k_b k_c k_d k_e S'_e = (0.92)(1)(1)(1)(0.83) (300 \text{ MPa}) \\ &= (0.764)(300 \text{ MPa}) = 229.1 \text{ MPa} \end{aligned}$$

Step 9. Calculate the mean force (F_m) and the alternating force (F_a) as

$$\begin{aligned} F_m &= \frac{F_{\max} + F_{\min}}{2} = \frac{(25.2 \text{ N}) + (10.8 \text{ N})}{2} = \frac{36 \text{ N}}{2} = 18 \text{ N} \\ F_a &= \frac{F_{\max} - F_{\min}}{2} = \frac{(25.2 \text{ N}) - (10.8 \text{ N})}{2} = \frac{14.4 \text{ N}}{2} = 7.2 \text{ N} \end{aligned}$$

Step 10. Calculate the mean bending moment (M_m) and the alternating bending moment (M_a) as

$$\begin{aligned} M_m &= F_m L = (18 \text{ N}) (6 \text{ cm}) = 108 \text{ N} \cdot \text{cm} = 1.08 \text{ N} \cdot \text{m} \\ M_a &= F_a L = (7.2 \text{ N}) (6 \text{ cm}) = 43.2 \text{ N} \cdot \text{cm} = 0.43 \text{ N} \cdot \text{m} \end{aligned}$$

Step 11. Calculate the area moment of inertia (I) for the rectangular cross section as

$$I = \frac{1}{12}bh^3 = \frac{1}{12}(1.25 \text{ cm})(0.16 \text{ cm})^3 = 4.27 \times 10^{-4} \text{ cm}^4 = 4.27 \times 10^{-12} \text{ m}^4$$

Step 12. Calculate the mean bending stress (σ_m) and the alternating bending stress (σ_a) as

$$\sigma_m = \frac{M_m c}{I} = \frac{(1.08 \text{ N} \cdot \text{m})(0.0008 \text{ m})}{4.27 \times 10^{-12} \text{ m}^4} = 202.3 \text{ MPa}$$

$$\sigma_a = \frac{M_a c}{I} = \frac{(0.43 \text{ N} \cdot \text{m})(0.0008 \text{ m})}{4.27 \times 10^{-12} \text{ m}^4} = 80.6 \text{ MPa}$$

Step 13. Plot the mean bending stress (σ_m) and alternating bending stress (σ_a) from step 12, the given ultimate tensile strength (S_{ut}), and the endurance limit (S_e) calculated in step 8 in a Goodman diagram like that shown in Fig. 7.19.

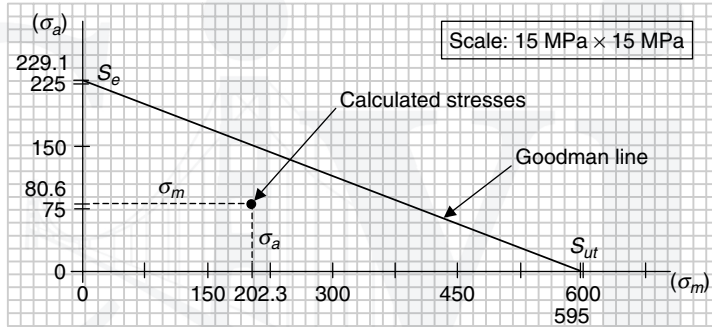

FIGURE 7.19 Goodman diagram for Example 1 (SI/metric).

Step 14. To answer question (a), calculate the factor-of-safety (n) using Eq. (7.25), which represents the distance (d) in Fig. 7.12.

$$\frac{1}{n} = \frac{\sigma_a}{S_e} + \frac{\sigma_m}{S_{ut}} = \frac{80.6 \text{ MPa}}{229.1 \text{ MPa}} + \frac{202.3 \text{ MPa}}{595 \text{ MPa}} = (0.352) + (0.340) = 0.692$$

$$n = \frac{1}{0.692} = 1.45$$

Step 15. To answer question (b), calculate the factor-of-safety (n_m) using Eq. (7.27), which represents the distance (d_m) in Fig. 7.13.

$$n_m = \frac{\sigma_a |_{\sigma_m}}{\sigma_a} = \frac{S_e \left(1 - \frac{\sigma_m}{S_{ut}}\right)}{\sigma_a} = \frac{(229.1 \text{ MPa}) \left(1 - \frac{202.3 \text{ MPa}}{595 \text{ MPa}}\right)}{80.6 \text{ MPa}} = \frac{(229.1 \text{ MPa})(0.660)}{80.6 \text{ MPa}}$$

$$= \frac{151.2 \text{ MPa}}{80.6 \text{ MPa}} = 1.88$$

where the alternating stress ($\sigma_a |_{\sigma_m}$) was substituted from Eq. (7.28).

Step 16. To answer question (c), calculate the factor-of-safety (n_a) using Eq. (7.29), which represents the distance (d_a) in Fig. 7.14.

$$\begin{aligned} n_a &= \frac{\sigma_m |_{\sigma_a}}{\sigma_m} = \frac{S_{ut} \left(1 - \frac{\sigma_a}{S_e}\right)}{\sigma_m} = \frac{(595 \text{ MPa}) \left(1 - \frac{80.6 \text{ MPa}}{229.1 \text{ MPa}}\right)}{202.3 \text{ MPa}} = \frac{(595 \text{ MPa})(0.648)}{202.3 \text{ MPa}} \\ &= \frac{385.6 \text{ MPa}}{202.3 \text{ MPa}} = 1.91 \end{aligned}$$

where the alternating stress ($\sigma_m |_{\sigma_a}$) was substituted from Eq. (7.30).

Step 17. To answer question (d), calculate the factor-of-safety (n_c) using Eq. (7.31), which represents the distance (d_c) in Fig. 7.15.

$$\begin{aligned} n_c &= \frac{\sigma_m |_c}{\sigma_m} = \frac{\frac{S_e}{S_{ut} + \frac{\sigma_a}{\sigma_m}}}{\sigma_m} = \frac{S_e}{\sigma_m \left(\frac{S_e}{S_{ut}} + \frac{\sigma_a}{\sigma_m}\right)} \\ &= \frac{229.1 \text{ MPa}}{(202.3 \text{ MPa}) \left(\frac{229.1 \text{ MPa}}{595 \text{ MPa}} + \frac{80.6 \text{ MPa}}{202.3 \text{ MPa}}\right)} = \frac{229.1 \text{ MPa}}{(202.3 \text{ MPa})(0.385 + 0.398)} \\ &= \frac{229.1 \text{ MPa}}{(202.3 \text{ MPa})(0.783)} = \frac{229.1 \text{ MPa}}{158.4 \text{ MPa}} = 1.45 \end{aligned}$$

where the alternating stress ($\sigma_m |_c$) was substituted from Eq. (7.32).

Notice that the factors-of-safety for parts (a) and (d) are the same, and the factors-of-safety for parts (b) and (c) are very close. This is not unexpected. Also, the factors-of-safety for all four parts could have been found graphically by scaling the appropriate distances in Fig. 7.19.

Consider another example where a fluctuating axial load is acting together with a constant axial load.

U.S. Customary

Example 2. For the stepped rod shown in Fig. 7.20, which is acted upon by both a fluctuating axial force (F_1) of between -200 lb and 800 lb and a constant axial force (F_2) of 500 lb, determine

- a. The factor-of-safety (n) using the Goodman theory
- b. The maximum range of values for the fluctuating axial force (F_1) if the mean force (F_m) is held constant

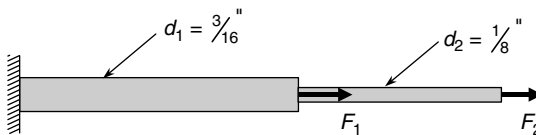

FIGURE 7.20 Stepped rod for Example 2 (U.S. Customary).

The stepped rod is made of high-strength steel, ground to the dimensions shown. The stepped rod operates at room temperature. Also, the test specimen endurance limit (S'_e) is

given, rather than obtained from the guidelines in Eq. (7.1).

$$S_{ut} = 105 \text{ kpsi}$$

$$S'_e = 65 \text{ kpsi}$$

$$K_f = 1.15 \text{ (due to change in diameter)}$$

solution

Step 1. Using Eq. (7.8) and values for the coefficient (a) and exponent (b) from Table 7.1, calculate the surface finish factor (k_a) as

$$k_a = a S_{ut}^b = (1.34 \text{ kpsi}) (105 \text{ kpsi})^{-0.085} = (1.34) (0.6733) = 0.90$$

Step 2. Only the larger diameter region of the stepped rod experiences the fluctuating axial force (F_1), so use diameter (d_1) in Eq. (7.10) to calculate the size factor (k_b) as

$$k_b = \left(\frac{d}{0.3} \right)^{-0.1133} = \left(\frac{0.1875}{0.3} \right)^{-0.1133} = (0.625)^{-0.1133} = 1.05 \cong 1$$

Step 3. The stepped rod is axially loaded, so the load type factor (k_c) from the guidelines in Eq. (7.13) is

$$k_c = 0.923$$

Step 4. As the stepped rod is operating at room temperature, the temperature factor (k_d) from Eq. (7.15) and Table 7.2 is

$$k_d = 1$$

Step 5. Using the given reduced stress concentration factor (K_f), calculate the miscellaneous effect factor (k_e) using Eq. (7.16) as

$$k_e = \frac{1}{K_f} = \frac{1}{1.15} = 0.87$$

Step 6. Using the given test specimen endurance limit (S'_e) and the modifying factors found in steps 1 through 5, calculate the endurance limit (S_e) for the stepped rod using the Marin equation in Eq. (7.7) as

$$\begin{aligned} S_e &= k_a k_b k_c k_d k_e S'_e = (0.90)(1)(0.923)(1)(0.87) (65 \text{ kpsi}) \\ &= (0.723)(65 \text{ kpsi}) = 47.0 \text{ kpsi} \end{aligned}$$

Step 7. Calculate the maximum axial force (F_{\max}) and minimum axial force (F_{\min}) as

$$F_{\max} = F_1^{\max} + F_2 = (800 \text{ lb}) + (500 \text{ lb}) = 1300 \text{ lb}$$

$$F_{\min} = F_1^{\min} + F_2 = (-200 \text{ lb}) + (500 \text{ lb}) = 300 \text{ lb}$$

Step 8. Calculate the mean axial force (F_m) and the alternating axial force (F_a) as

$$F_m = \frac{F_{\max} + F_{\min}}{2} = \frac{(1,300 \text{ lb}) + (300 \text{ lb})}{2} = \frac{1,600 \text{ lb}}{2} = 800 \text{ lb}$$

$$F_a = \frac{F_{\max} - F_{\min}}{2} = \frac{(1,300 \text{ lb}) - (300 \text{ lb})}{2} = \frac{1,000 \text{ lb}}{2} = 500 \text{ lb}$$

Step 9. Calculate the area (A) of the larger diameter (d_1) for the stepped rod as

$$A = \frac{\pi}{4} d_1^2 = \frac{\pi}{4} \left(\frac{3}{16} \text{ in} \right)^2 = 0.0276 \text{ in}^2$$

Step 10. Calculate the mean axial stress (σ_m) and the alternating axial stress (σ_a) as

$$\sigma_m = \frac{F_m}{A} = \frac{800 \text{ lb}}{0.0276 \text{ in}^2} = 29.0 \text{ kpsi}$$

$$\sigma_a = \frac{F_a}{A} = \frac{500 \text{ lb}}{0.0276 \text{ in}^2} = 18.1 \text{ kpsi}$$

Step 11. Plot the mean axial stress (σ_m) and alternating axial stress (σ_a) from step 10, the given ultimate tensile strength (S_{ut}), and the endurance limit (S_e) calculated in step 6 in a Goodman diagram like that shown in Fig. 7.21.

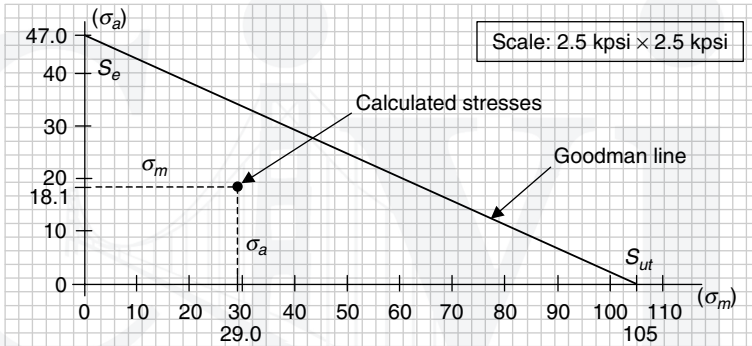

FIGURE 7.21 Goodman diagram for Example 2 (U.S. Customary).

Step 12. To answer question (a), calculate the factor-of-safety (n) using Eq. (7.25), which represents the distance (d) in Fig. 7.12.

$$\frac{1}{n} = \frac{\sigma_a}{S_e} + \frac{\sigma_m}{S_{ut}} = \frac{18.1 \text{ kpsi}}{47.0 \text{ kpsi}} + \frac{29.0 \text{ kpsi}}{105 \text{ kpsi}} = (0.385) + (0.276) = 0.661$$

$$n = \frac{1}{0.661} = 1.51$$

Step 13. To answer question (b), calculate the factor-of-safety (n_m) using Eq. (7.27), which represents the distance (d_m) in Fig. 7.13.

$$\begin{aligned} n_m &= \frac{\sigma_a |_{\sigma_m}}{\sigma_a} = \frac{S_e \left(1 - \frac{\sigma_m}{S_{ut}} \right)}{\sigma_a} = \frac{(47.0 \text{ kpsi}) \left(1 - \frac{29.0 \text{ kpsi}}{105 \text{ kpsi}} \right)}{18.1 \text{ kpsi}} = \frac{(47.0 \text{ kpsi}) (0.724)}{18.1 \text{ kpsi}} \\ &= \frac{34.03 \text{ kpsi}}{18.1 \text{ kpsi}} = 1.88 \end{aligned}$$

where the alternating stress ($\sigma_a |_{\sigma_m}$) was substituted from Eq. (7.28).

Step 14. Multiply the factor-of-safety (n_m) found in step 13 times the alternating axial force (F_a) to give a maximum alternating axial force (F_a^{\max}) as

$$F_a^{\max} = n_m F_a = (1.88) (500 \text{ lb}) = 940 \text{ lb}$$

Step 15. Use the maximum alternating axial force (F_a^{\max}) found in step 14 to determine the limiting values of the maximum axial force (F_{\max}) and the minimum axial force (F_{\min}).

$$F_{\max}^{\text{lim}} = F_m + F_a^{\max} = (800 \text{ lb}) + (940 \text{ lb}) = 1,740 \text{ lb}$$

$$F_{\min}^{\text{lim}} = F_m - F_a^{\max} = (800 \text{ lb}) - (940 \text{ lb}) = -140 \text{ lb}$$

Step 16. Subtract the constant axial force (F_2) from the limiting values in step 15 to give the limiting range of the fluctuating axial force (F_1) forcing the factor-of-safety to be 1.

$$F_1^{\max} = F_{\max}^{\text{lim}} - F_2 = (1,740 \text{ lb}) - (500 \text{ lb}) = 1,240 \text{ lb}$$

$$F_1^{\min} = F_{\min}^{\text{lim}} - F_2 = (-140 \text{ lb}) - (500 \text{ lb}) = -640 \text{ lb}$$

This means the limiting range on the fluctuating force (F_1) is -640 lb to $1,240 \text{ lb}$.

SI/metric

Example 2. For the stepped rod shown in Fig. 7.22, which is acted upon by both a fluctuating axial force (F_1) of between -900 N and $3,600 \text{ N}$ and a constant axial force (F_2) of $2,250 \text{ N}$, determine

- The factor-of-safety (n) using the Goodman theory
- The maximum range of values for the fluctuating axial force (F_1) if the mean force (F_m) is held constant

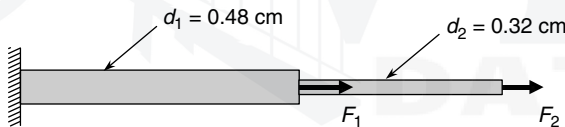

FIGURE 7.22 Stepped rod for Example 2 (SI/metric).

The stepped rod is made of high-strength steel, ground to the dimensions shown. The stepped rod operates at room temperature. Also, the test specimen endurance limit (S'_e) is given, rather than obtained from the guidelines in Eq. (7.1).

$$S_{ut} = 735 \text{ MPa}$$

$$S'_e = 455 \text{ MPa}$$

$$K_f = 1.15 \text{ (due to change in diameter)}$$

solution

Step 1. Using Eq. (7.8) and values for the coefficient (a) and exponent (b) from Table 7.1, calculate the surface finish factor (k_a) as

$$k_a = a S_{ut}^b = (1.58 \text{ MPa})(735 \text{ MPa})^{-0.085} = (1.58) (0.5706) = 0.90$$

Step 2. Only the larger diameter region of the stepped rod experiences the fluctuating axial force (F_1), so use diameter (d_1) in Eq. (7.10) to calculate the size factor (k_b) as

$$k_b = \left(\frac{d}{7.62}\right)^{-0.1133} = \left(\frac{4.8}{7.62}\right)^{-0.1133} = (0.630)^{-0.1133} = 1.05 \cong 1$$

Step 3. The stepped rod is axially loaded, so the load type factor (k_c) from the guidelines in Eq. (7.13) is

$$k_c = 0.923$$

Step 4. As the stepped rod is operating at room temperature, the temperature factor (k_d) from Eq. (7.15) and Table 7.2 is

$$k_d = 1$$

Step 5. Using the given reduced stress concentration factor (K_f), calculate the miscellaneous effect factor (k_e) using Eq. (7.16) as

$$k_e = \frac{1}{K_f} = \frac{1}{1.15} = 0.87$$

Step 6. Using the given test specimen endurance limit (S'_e) and the modifying factors found in steps 1 through 5, calculate the endurance limit (S_e) for the stepped rod using the Marin equation in Eq. (7.7) as

$$\begin{aligned} S_e &= k_a k_b k_c k_d k_e S'_e = (0.90)(1)(0.923)(1)(0.87)(455 \text{ MPa}) \\ &= (0.723)(455 \text{ MPa}) = 329.0 \text{ MPa} \end{aligned}$$

Step 7. Calculate the maximum axial force (F_{\max}) and minimum axial force (F_{\min}) as

$$\begin{aligned} F_{\max} &= F_1^{\max} + F_2 = (3,600 \text{ N}) + (2,250 \text{ N}) = 5,850 \text{ N} \\ F_{\min} &= F_1^{\min} + F_2 = (-900 \text{ N}) + (2,250 \text{ N}) = 1,350 \text{ N} \end{aligned}$$

Step 8. Calculate the mean axial force (F_m) and the alternating axial force (F_a) as

$$\begin{aligned} F_m &= \frac{F_{\max} + F_{\min}}{2} = \frac{(5,850 \text{ N}) + (1,350 \text{ N})}{2} = \frac{7,200 \text{ lb}}{2} = 3,600 \text{ N} \\ F_a &= \frac{F_{\max} - F_{\min}}{2} = \frac{(5,850 \text{ N}) - (1,350 \text{ N})}{2} = \frac{4,500 \text{ lb}}{2} = 2,250 \text{ N} \end{aligned}$$

Step 9. Calculate the area (A) of the larger diameter (d_1) for stepped rod as

$$A = \frac{\pi}{4} d_1^2 = \frac{\pi}{4} (0.48 \text{ cm})^2 = 0.181 \text{ cm}^2 = 1.81 \times 10^{-5} \text{ m}^2$$

Step 10. Calculate the mean axial stress (σ_m) and the alternating axial stress (σ_a) as

$$\begin{aligned} \sigma_m &= \frac{F_m}{A} = \frac{3,600 \text{ N}}{1.81 \times 10^{-5} \text{ m}^2} = 198.9 \text{ MPa} \\ \sigma_a &= \frac{F_a}{A} = \frac{2,250 \text{ N}}{1.81 \times 10^{-5} \text{ m}^2} = 124.3 \text{ MPa} \end{aligned}$$

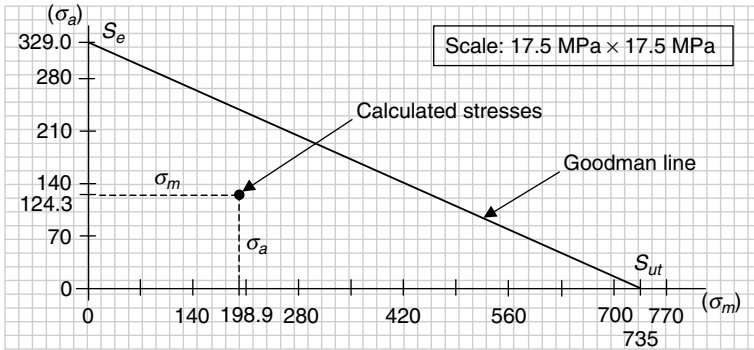

FIGURE 7.23 Goodman diagram for Example 2 (SI/metric).

Step 11. Plot the mean axial stress (σ_m) and alternating axial stress (σ_a) from step 10, the given ultimate tensile strength (S_{ut}), and the endurance limit (S_e) calculated in step 6 in a Goodman diagram like that shown in Fig. 7.23.

Step 12. To answer question (a), calculate the factor-of-safety (n) using Eq. (7.25), which represents the distance (d) in Fig. 7.12.

$$\frac{1}{n} = \frac{\sigma_a}{S_e} + \frac{\sigma_m}{S_{ut}} = \frac{124.3 \text{ MPa}}{329.0 \text{ MPa}} + \frac{198.9 \text{ MPa}}{735 \text{ MPa}} = (0.378) + (0.271) = 0.649$$

$$n = \frac{1}{0.649} = 1.54$$

Step 13. To answer question (b), calculate the factor-of-safety (n_m) using Eq. (7.27), which represents the distance (d_m) in Fig. 7.13.

$$n_m = \frac{\sigma_a |_{\sigma_m}}{\sigma_a} = \frac{S_e \left(1 - \frac{\sigma_m}{S_{ut}}\right)}{\sigma_a} = \frac{(329.0 \text{ MPa}) \left(1 - \frac{198.9 \text{ MPa}}{735 \text{ MPa}}\right)}{124.3 \text{ MPa}} = \frac{(329.0 \text{ MPa})(0.729)}{124.3 \text{ MPa}}$$

$$= \frac{239.84 \text{ MPa}}{124.3 \text{ MPa}} = 1.93$$

where the alternating stress ($\sigma_a |_{\sigma_m}$) was substituted from Eq. (7.28).

Step 14. Multiply the factor-of-safety (n_m) found in step 13 with the alternating axial force (F_a) to give a maximum alternating axial force (F_a^{\max}) as

$$F_a^{\max} = n_m F_a = (1.93)(2,250 \text{ N}) = 4,343 \text{ N}$$

Step 15. Use the maximum alternating axial force (F_a^{\max}) found in step 14 to determine the limiting values of the maximum axial force (F_{\max}) and the minimum axial force (F_{\min}).

$$F_{\max}^{\text{lim}} = F_m + F_a^{\max} = (3,600 \text{ N}) + (4,343 \text{ N}) = 7,943 \text{ N}$$

$$F_{\min}^{\text{lim}} = F_m - F_a^{\max} = (3,600 \text{ N}) - (4,343 \text{ N}) = -743 \text{ N}$$

Step 16. Subtract the constant axial force (F_2) from the limiting values in step 15 to give the limiting range of the fluctuating axial force (F_1) forcing the factor-of-safety to be 1.

$$F_1^{\max} = F_{\max}^{\text{lim}} - F_2 = (7,943 \text{ N}) - (2,250 \text{ N}) = 5,693 \text{ N}$$

$$F_1^{\min} = F_{\min}^{\text{lim}} - F_2 = (-743 \text{ N}) - (2,250 \text{ N}) = -2,993 \text{ N}$$

This means the limiting range on the fluctuating force (F_1) is $-2,993$ to $5,693$ N.

Alternative Method to Account for Stress Concentrations. The factor-of-safety (n) according to the Goodman theory was by Eq. (7.25), repeated here

$$\frac{\sigma_a}{S_e} + \frac{\sigma_m}{S_{ut}} = \frac{1}{n} \quad (7.25)$$

In the determination of the endurance limit (S_e) in the denominator of the first term, one of the modifying factors in the Marin equation was the miscellaneous effect factor (k_e), where if there were stress concentrations, this factor was given by Eq. (7.16), also repeated here

$$k_e = \frac{1}{K_f} \quad (7.16)$$

where the reduced stress concentration factor (K_f) was found from Eq. (6.23) as

$$K_f = 1 + q(K_t - 1) \quad (6.23)$$

with (K_t) being the geometric stress concentration factor and (q) being the notch sensitivity.

If the miscellaneous effect factor (k_e) is separated from the endurance limit (S_e) in the Goodman theory equation, then Eq. (7.25) can be rearranged as follows:

$$\underbrace{\frac{\sigma_a}{S_e(k_e)} + \frac{\sigma_m}{S_{ut}}}_{\text{separate out } k_e} = \frac{\sigma_a}{S_e \left(\frac{1}{K_f} \right)} + \frac{\sigma_m}{S_{ut}} = \underbrace{\frac{K_f \sigma_a}{S_e} + \frac{\sigma_m}{S_{ut}}}_{\text{move } K_f \text{ to numerator}} = \frac{1}{n}$$

substitute for K_f

where now the reduced stress concentration factor (K_f) is multiplied by the alternating stress (σ_a). This is a very important point, that any stress concentrations affect *only* the alternating stress (σ_a), not the mean stress (σ_m). However, extreme care must be taken to make sure the reduced stress concentration factor (K_f) is not left out, or included twice.

Fluctuations in Torsional Loading. If the fluctuating loading on a machine element is torsional, then there will be a mean *shear* stress (τ_m) and an alternating *shear* stress (τ_a). The test specimen endurance limit (S'_e) is still determined from the guidelines in Eq. (7.1); however, there will be an ultimate *shear* strength (S_{us}) defined as

$$S_{us} = (0.67)S_{ut} \quad (7.33)$$

where the factor 0.67 is due to the work by Robert E. Joerres [Chap. 6, Springs, in Shigley, Mischke, & Brown, 2004] at Associated Spring—Barnes Group.

Also, when calculating the endurance limit (S_e) from the Marin equation, Eq. (7.7), use a loading factor (k_c) of 0.577. The other modifying factors are the same.

The Goodman theory can be used to determine if a design is safe under fluctuating torsional loading; however, use the ultimate shear strength (S_{us}) instead of the ultimate tensile strength (S_{ut}). This changes the equation for the factor-of-safety (n) according to the Goodman theory to be

$$\frac{\tau_a}{S_e} + \frac{\tau_m}{S_{us}} = \frac{1}{n} \quad (7.34)$$

and plotted as the straight line in Fig. 7.24.

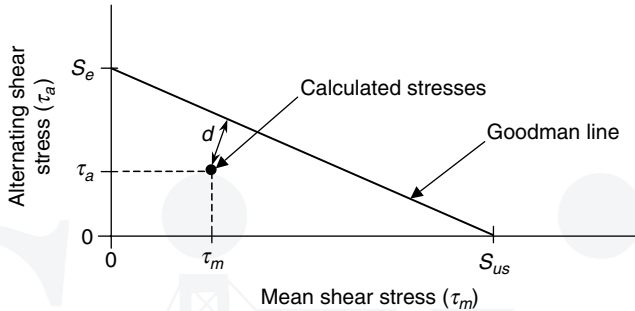

FIGURE 7.24 Goodman theory for fluctuating torsional loading.

Consider the following example of a solid circular shaft under fluctuating torsional loading, in both the U.S. Customary and SI/metric system of units.

U.S. Customary

Example 3. For the solid shaft shown in Fig. 7.25, which is acted upon by a fluctuating torque (T) of between (1,800 ft · lb) and (2,200 ft · lb), determine the factor-of-safety (n) using the Goodman theory.

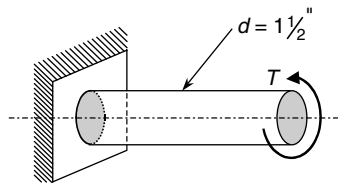

FIGURE 7.25 Shaft for Example 3 (U.S. Customary).

The solid shaft is *as forged* steel at the diameter shown, and has a (1/8 in) wide hemispherical groove (not shown) around the circumference of the shaft. The shaft operates at room temperature. Also,

$$\begin{aligned} S_{ut} &= 90 \text{ kpsi} \\ K_{ts} &= 1.65 \text{ (due to circumferential groove)} \\ q &= 0.9 \text{ (notch sensitivity)} \end{aligned}$$

solution

Step 1. Using Eq. (7.8) and the values for the coefficient (a) and exponent (b) from Table 7.1, calculate the surface finish factor (k_a) as

$$k_a = a S_{ut}^b = (39.9 \text{ kpsi}) (90 \text{ kpsi})^{-0.995} = (39.9) (0.0114) = 0.45$$

Step 2. Using Eq. (7.10) and the given diameter, calculate the size factor (k_b) as

$$k_b = \left(\frac{d}{0.3} \right)^{-0.1133} = \left(\frac{1.5}{0.3} \right)^{-0.1133} = (5)^{-0.1133} = 0.83$$

Step 3. The shaft is in torsion so the load type factor (k_c) from Eq. (7.14) is

$$k_c = 0.577$$

Step 4. As the shaft is operating at room temperature, the temperature factor (k_d) from Eq. (7.15) and Table 7.2 is

$$k_d = 1$$

Step 5. Using the given geometric shear stress concentration factor (K_{ts}) and the notch sensitivity (q), calculate the reduced concentration factor (K_f) from Eq. (6.23) as

$$K_f = 1 + q(K_{ts} - 1) = 1 + (0.9)(1.65 - 1) = 1 + 0.585 = 1.585$$

Step 6. Using the reduced stress concentration factor (K_f) found in step 5, calculate the miscellaneous effect factor (k_e) using Eq. (7.16) as

$$k_e = \frac{1}{K_f} = \frac{1}{1.585} = 0.63$$

Step 7. Using the given ultimate tensile stress (S_{ut}) and the guidelines in Eq. (7.1), calculate the test specimen endurance limit (S'_e) as

$$S'_e = 0.504 S_{ut} = (0.504)(90 \text{ kpsi}) = 45.4 \text{ kpsi}$$

Step 8. Using the test specimen endurance limit (S'_e) found in step 7, and the modifying factors found in steps 1 through 6, calculate the endurance limit (S_e) for the solid shaft using the Marin equation in Eq. (7.7) as

$$\begin{aligned} S_e &= k_a k_b k_c k_d k_e S'_e = (0.45)(0.83)(0.577)(1)(0.63) (45.4 \text{ kpsi}) \\ &= (0.136)(45.4 \text{ kpsi}) = 6.2 \text{ kpsi} \end{aligned}$$

Step 9. Calculate the mean torque (T_m) and the alternating torque (T_a) as

$$\begin{aligned} T_m &= \frac{T_{\max} + T_{\min}}{2} = \frac{(2,200 \text{ ft} \cdot \text{lb}) + (1,800 \text{ ft} \cdot \text{lb})}{2} \\ &= \frac{4,000 \text{ ft} \cdot \text{lb}}{2} = 2,000 \text{ ft} \cdot \text{lb} = 24,000 \text{ in} \cdot \text{lb} \\ T_a &= \frac{T_{\max} - T_{\min}}{2} = \frac{(2,200 \text{ ft} \cdot \text{lb}) - (1,800 \text{ ft} \cdot \text{lb})}{2} \\ &= \frac{400 \text{ ft} \cdot \text{lb}}{2} = 200 \text{ ft} \cdot \text{lb} = 2,400 \text{ in} \cdot \text{lb} \end{aligned}$$

Step 10. Calculate the polar moment of inertia (J) of the circular cross section as

$$J = \frac{1}{2}\pi R^4 = \frac{1}{2}\pi(0.75 \text{ in})^4 = 0.497 \text{ in}^4$$

Step 11. Calculate the mean shear stress (τ_m) and the alternating shear stress (τ_a) as

$$\tau_m = \frac{T_m R}{J} = \frac{(24,000 \text{ in} \cdot \text{lb})(0.75 \text{ in})}{0.497 \text{ in}^4} = 36.2 \text{ kpsi}$$

$$\tau_a = \frac{T_a R}{J} = \frac{(2,400 \text{ in} \cdot \text{lb})(0.75 \text{ in})}{0.497 \text{ in}^4} = 3.6 \text{ kpsi}$$

Step 12. Using the given ultimate tensile stress (S_{ut}) and Eq. (7.33), calculate the ultimate shear strength (S_{us}) as

$$S_{us} = 0.67 S_{ut} = (0.67)(90 \text{ kpsi}) = 60.3 \text{ kpsi}$$

Step 13. Calculate the factor-of-safety (n) using Eq. (7.34), which represents the distance (d) in Fig. 7.24, as

$$\frac{1}{n} = \frac{\tau_a}{S_e} + \frac{\tau_m}{S_{us}} = \frac{3.6 \text{ kpsi}}{6.2 \text{ kpsi}} + \frac{36.2 \text{ kpsi}}{60.3 \text{ kpsi}} = (0.581) + (0.600) = 1.181$$

$$n = \frac{1}{1.181} = 0.85 \text{ (unsafe!)}$$

which means the design is unsafe because the factor-of-safety n is less than 1.

Step 14. Plot the mean shear stress (τ_m) and alternating shear stress (τ_a) from step 11, the ultimate shear strength (S_{us}) found from step 12, and the endurance limit (S_e) calculated in step 8 in a Goodman diagram like that shown in Fig. 7.26.

Notice the point (τ_m, τ_a) representing the calculated shear stresses falls outside the Goodman line, which confirms that the design is unsafe as determined mathematically in step 13. The main reason the design is unsafe is the fact that in step 8 the test specimen endurance limit (S'_e) was reduced by over 85 percent, primarily due to the surface finish factor (k_a) that was calculated in step 1 to be 0.45, which is a 55 percent reduction by itself.

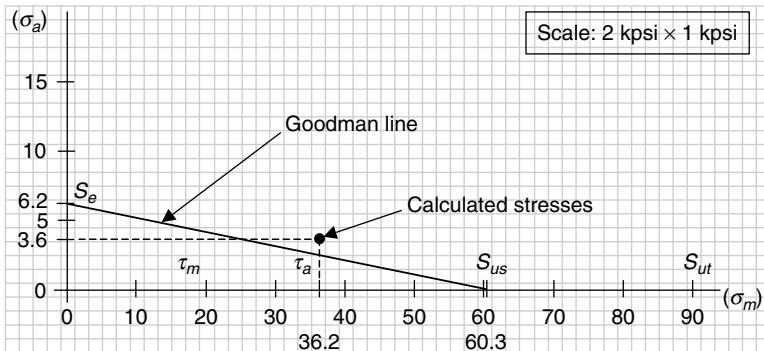

FIGURE 7.26 Goodman diagram for Example 3 (U.S. Customary).

Just for curiosity, what if the endurance limit were doubled, from 6.2 kpsi to 12.4 kpsi, how would this change the factor-of-safety (n)? Substituting this new value for the endurance limit (S_e) into the Goodman theory, previously calculated in step 13 above, gives a safe value.

$$\frac{1}{n} = \frac{\tau_a}{S_e} + \frac{\tau_m}{S_{us}} = \frac{3.6 \text{ kpsi}}{12.4 \text{ kpsi}} + \frac{36.2 \text{ kpsi}}{60.3 \text{ kpsi}} = (0.290) + (0.600) = 0.89$$

$$n = \frac{1}{0.89} = 1.12 \text{ (safe!)}$$

SI/metric

Example 3. For the solid shaft shown in Fig. 7.27, which is acted upon by a fluctuating torque (T) of between 2,700 N · m and 3,300 N · m, determine the factor-of-safety (n) using the Goodman theory.

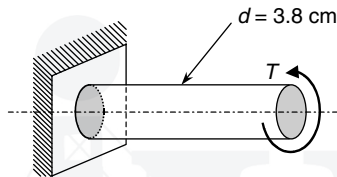

FIGURE 7.27 Shaft for Example 3 (SI/metric).

The solid shaft is *as forged* steel at the diameter shown, and has a (3 mm) wide hemispherical groove (not shown) around the circumference of the shaft. The shaft operates at room temperature. Also,

$$S_{ut} = 630 \text{ MPa}$$

$$K_{ts} = 1.65 \text{ (due to circumferential groove)}$$

$$q = 0.9 \text{ (notch sensitivity)}$$

solution

Step 1. Using Eq. (7.8) and values for the coefficient (a) and exponent (b) from Table 7.1, calculate the surface finish factor (k_a) as

$$k_a = aS_{ut}^b = (272 \text{ MPa})(630 \text{ MPa})^{-0.995} = (272)(0.00164) = 0.45$$

Step 2. Using Eq. (7.10) and the given diameter, calculate the size factor (k_b) as

$$k_b = \left(\frac{d}{7.62} \right)^{-0.1133} = \left(\frac{38}{7.62} \right)^{-0.1133} = (5)^{-0.1133} = 0.83$$

Step 3. The shaft is in torsion so the load type factor (k_c) from Eq. (7.14) is

$$k_c = 0.577$$

Step 4. As the shaft is operating at room temperature, the temperature factor (k_d) from Eq. (7.15) and Table 7.2 is

$$k_d = 1$$

Step 5. Using the given geometric shear stress concentration factor (K_{ts}) and the notch sensitivity (q), calculate the reduced concentration factor (K_f) from Eq. (6.23) as

$$K_f = 1 + q(K_{ts} - 1) = 1 + (0.9)(1.65 - 1) = 1 + 0.585 = 1.585$$

Step 6. Using the reduced stress concentration factor (K_f) found in step 5, calculate the miscellaneous effect factor (k_e) using Eq. (7.16) as

$$k_e = \frac{1}{K_f} = \frac{1}{1.585} = 0.63$$

Step 7. Using the given ultimate tensile stress (S_{ut}) and the guidelines in Eq. (7.1), calculate the test specimen endurance limit (S'_e) as

$$S'_e = 0.504 S_{ut} = (0.504)(630 \text{ MPa}) = 317.5 \text{ MPa}$$

Step 8. Using the test specimen endurance limit (S'_e) found in step 7, and the modifying factors found in steps 1 through 6, calculate the endurance limit (S_e) for the solid shaft using the Marin equation in Eq. (7.7) as

$$\begin{aligned} S_e &= k_a k_b k_c k_d k_e S'_e = (0.45)(0.83)(0.577)(1)(0.63)(317.5 \text{ MPa}) \\ &= (0.136)(317.5 \text{ MPa}) = 43.2 \text{ MPa} \end{aligned}$$

Step 9. Calculate the mean torque (T_m) and the alternating torque (T_a) as

$$\begin{aligned} T_m &= \frac{T_{\max} + T_{\min}}{2} = \frac{(3,300 \text{ N} \cdot \text{m}) + (2,700 \text{ N} \cdot \text{m})}{2} \\ &= \frac{6,000 \text{ N} \cdot \text{m}}{2} = 3,000 \text{ N} \cdot \text{m} \end{aligned}$$

$$\begin{aligned} T_a &= \frac{T_{\max} - T_{\min}}{2} = \frac{(3,300 \text{ N} \cdot \text{m}) - (2,700 \text{ N} \cdot \text{m})}{2} \\ &= \frac{600 \text{ N} \cdot \text{m}}{2} = 300 \text{ N} \cdot \text{m} \end{aligned}$$

Step 10. Calculate the polar moment of inertia (J) of the circular cross section as

$$J = \frac{1}{2} \pi R^4 = \frac{1}{2} \pi (1.9 \text{ cm})^4 = 20.47 \text{ cm}^4 = 2.05 \times 10^{-7} \text{ m}^4$$

Step 11. Calculate the mean shear stress (τ_m) and the alternating shear stress (τ_a) as

$$\begin{aligned} \tau_m &= \frac{T_m R}{J} = \frac{(3,000 \text{ N} \cdot \text{m})(0.019 \text{ m})}{2.05 \times 10^{-7} \text{ m}^4} = 278.0 \text{ MPa} \\ \tau_a &= \frac{T_a R}{J} = \frac{(300 \text{ N} \cdot \text{m})(0.019 \text{ m})}{2.05 \times 10^{-7} \text{ m}^4} = 27.8 \text{ MPa} \end{aligned}$$

Step 12. Using the given ultimate tensile stress (S_{ut}) and Eq. (7.33), calculate the ultimate shear strength (S_{us}) as

$$S_{us} = 0.67 S_{ut} = (0.67)(630 \text{ MPa}) = 422.1 \text{ MPa}$$

Step 13. Calculate the factor-of-safety (n) using Eq. (7.34), which represents the distance (d) in Fig. 7.24, as

$$\frac{1}{n} = \frac{\tau_a}{S_e} + \frac{\tau_m}{S_{us}} = \frac{27.8 \text{ MPa}}{43.2 \text{ MPa}} + \frac{278.0 \text{ MPa}}{422.1 \text{ MPa}} = (0.644) + (0.659) = 1.303$$

$$n = \frac{1}{1.303} = 0.77 \text{ (unsafe!)}$$

which means the design is unsafe, because the factor-of-safety n is less than 1.

The main reason the design is unsafe is the fact that in step 8 the test specimen endurance limit (S'_e) was reduced by over 85 percent, primarily due to the surface finish factor (k_a) that was calculated in step 1 to be 0.45, which is a 55 percent reduction by itself.

Just for curiosity, what if the endurance limit were doubled, from 43.2 MPa to 86.4 MPa, how would this change the factor-of-safety (n)? Substituting this new value for the endurance limit (S_e) into the Goodman theory, previously calculated in step 13 above, gives a safe value.

$$\frac{1}{n} = \frac{\tau_a}{S_e} + \frac{\tau_m}{S_{us}} = \frac{27.8 \text{ MPa}}{86.4 \text{ MPa}} + \frac{278.0 \text{ MPa}}{422.1 \text{ MPa}} = (0.322) + (0.659) = 0.981$$

$$n = \frac{1}{0.981} = 1.02 \text{ (not by much, but safe!)}$$

Step 14. Plot the mean shear stress (τ_m) and alternating shear stress (τ_a) from step 11, the ultimate shear strength (S_{us}) found from step 12, and the endurance limit (S_e) calculated in step 8 in a Goodman diagram like that shown in Fig. 7.28.

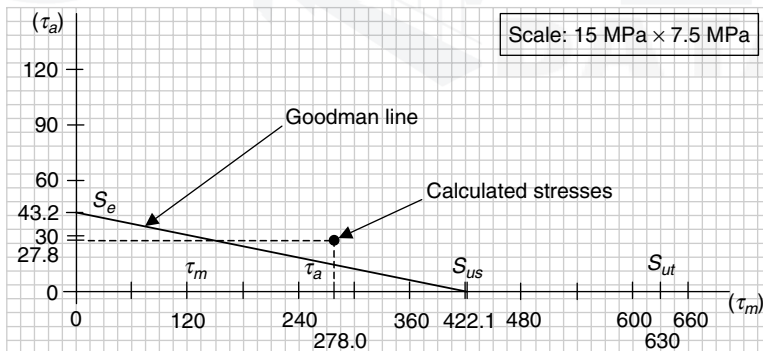

FIGURE 7.28 Goodman diagram for Example 3 (SI/metric).

Notice the point (τ_m, τ_a) representing the calculated shear stresses falls outside the Goodman line, which confirms that the design is unsafe as determined mathematically in step 13.

7.5 COMBINED LOADING

The third type of dynamic loading to be presented is combined loading, where the total load on the machine element is a combination of both normal (σ) and shear (τ) stresses, whether constant, reversed, or fluctuating. The steps of the analysis to determine whether the design is safe are as follows:

1. Calculate the endurance limit (S_e), except use a load type factor ($k_c = 1$) for bending, and do not apply the miscellaneous effects factor (k_e) due to the reduced stress concentration factors (K_f) as given in Eq. (7.35).

$$S_e = k_a k_b (1) k_d S'_e \quad (7.35)$$

2. Determine the normal (σ) and shear (τ) stresses, whether constant, reversed, or fluctuating, and display on a plane stress element.
3. Determine the maximum and minimum normal and shear stresses, that is, (σ_{\max}), (σ_{\min}), (τ_{\max}), and (τ_{\min}).
4. Determine the mean and alternating normal and shear stresses, that is, (σ_m), (σ_a), (τ_m), and (τ_a).
5. Apply any reduced stress concentration factors to the alternating stresses only, meaning multiply (K_f) times the appropriate (σ_a) or (τ_a).
6. Multiply any alternating axial stress by (1.083 = 1/0.923) to account for the load type factor ($k_c = 0.923$), because the endurance limit (S_e) determined in step 1 above assumes a load type factor for bending.
7. Use Mohr's circle, or the applicable equations, to determine two sets of principal stresses (σ_1) and (σ_2); one set for the mean stresses, (σ_m) and (τ_m), and the other set for the alternating stresses, (σ_a) and (τ_a).

$$\sigma_1^m, \sigma_2^m = \frac{\sigma_m}{2} \pm \sqrt{\left(\frac{\sigma_m}{2}\right)^2 + \tau_m^2} \quad (7.36)$$

$$\sigma_1^a, \sigma_2^a = \frac{\sigma_a}{2} \pm \sqrt{\left(\frac{\sigma_a}{2}\right)^2 + \tau_a^2} \quad (7.37)$$

8. Use the distortion-energy theory, normally used for the static design of ductile materials, to calculate both an effective mean stress (σ_m^{eff}) and an effective alternating stress (σ_a^{eff}).

$$\sigma_m^{\text{eff}} = \sqrt{(\sigma_1^m)^2 + (\sigma_2^m)^2 - (\sigma_1^m)(\sigma_2^m)} \quad (7.38)$$

$$\sigma_a^{\text{eff}} = \sqrt{(\sigma_1^a)^2 + (\sigma_2^a)^2 - (\sigma_1^a)(\sigma_2^a)} \quad (7.39)$$

9. Use the Goodman theory, either the mathematical equation or by plotting graphically the appropriate stresses to determine if the design is safe. The mathematical equation for the Goodman theory would therefore be

$$\frac{\sigma_a^{\text{eff}}}{S_e} + \frac{\sigma_m^{\text{eff}}}{S_{ut}} = \frac{1}{n} \quad (7.40)$$

where the factor-of-safety (n) represents the distance (d) in Fig. 7.29.

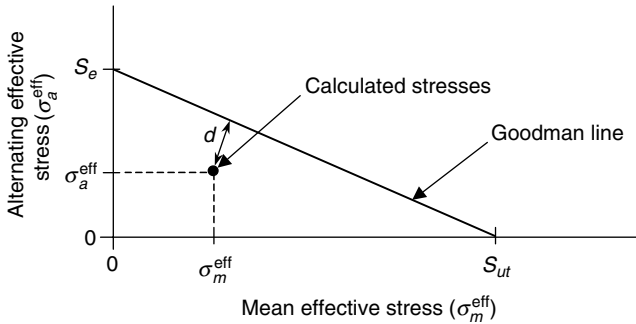

FIGURE 7.29 Goodman theory for combined loading.

Consider the following example that is a combination of both constant and varying loads, which produce both normal and shear stresses, and is presented in both the U.S. Customary and SI/metric system of units.

U.S. Customary

Example 1. A circular shaft is acted upon by a combination of loadings: an applied torque that produces a constant shear stress of 8 kpsi, an axial force that produces a constant normal stress of 10 kpsi, and a bending moment that produces a completely reversed normal stress of ± 20 kpsi. Determine the factor-of-safety (n) using the Goodman theory for combined loading.

The shaft is machined to a diameter of 1 in and has a keyway that results in a reduced stress concentration factor (K_f) equal to (1.15). The shaft operates at 200°F. Also, the ultimate tensile strength (S_{ut}) is 75 kpsi.

solution

Step 1A. Using Eq. (7.8) and values for the coefficient (a) and exponent (b) from Table 7.1, calculate the surface finish factor (k_a) as

$$k_a = a S_{ut}^b = (2.70 \text{ kpsi}) (75 \text{ kpsi})^{-0.265} = (2.70) (0.3185) = 0.86$$

Step 1B. Using Eq. (7.10) and the given diameter, calculate the size factor (k_b) as

$$k_b = \left(\frac{d}{0.3} \right)^{-0.1133} = \left(\frac{1}{0.3} \right)^{-0.1133} = (3.33)^{-0.1133} = 0.87$$

Step 1C. As required by the process, use the load type factor (k_c) for bending from Eq. (7.14) to be

$$k_c = 1$$

Step 1D. The shaft is operating at 200°F so the temperature factor (k_d) from Eq. (7.15) and Table 7.2 is

$$k_d = 1.020$$

Step 1E. Using the given ultimate tensile stress (S_{ut}) and the guidelines in Eq. (7.1), calculate the test specimen endurance limit (S'_e) as

$$S'_e = 0.504 S_{ut} = (0.504)(75 \text{ kpsi}) = 37.8 \text{ kpsi}$$

Step 1F. Using the test specimen endurance limit (S'_e) found in step 1E, and the modifying factors found in steps 1A through 1D, calculate the endurance limit (S_e) for the solid shaft using the Marin equation for combined loading in Eq. (7.35) as

$$\begin{aligned} S_e &= k_a k_b (1) k_d S'_e = (0.86)(0.87)(1)(1.020)(37.8 \text{ kpsi}) \\ &= (0.763)(37.8 \text{ kpsi}) = 28.8 \text{ kpsi} \end{aligned}$$

Step 2. The normal and shear stresses are given, and displayed in Fig. 7.30.

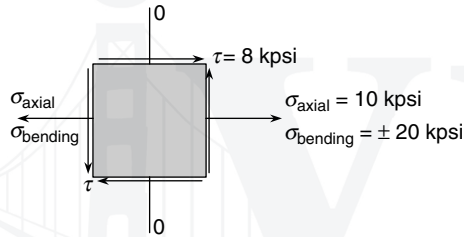

FIGURE 7.30 Plane stress element for Example 1 (U.S. Customary).

Step 3. Calculate the maximum normal stress (σ_{\max}) and the minimum normal stress (σ_{\min}) as

$$\sigma_{\max} = \sigma_{\text{axial}} + \sigma_{\text{bending}} = (10 \text{ kpsi}) + (20 \text{ kpsi}) = 30 \text{ kpsi}$$

$$\sigma_{\min} = \sigma_{\text{axial}} - \sigma_{\text{bending}} = (10 \text{ kpsi}) - (20 \text{ kpsi}) = -10 \text{ kpsi}$$

Step 4A. Calculate the mean normal stress (σ_m) and the alternating normal stress (σ_a) as

$$\sigma_m = \frac{\sigma_{\max} + \sigma_{\min}}{2} = \frac{(30 \text{ kpsi}) + (-10 \text{ kpsi})}{2} = \frac{20 \text{ kpsi}}{2} = 10 \text{ kpsi}$$

$$\sigma_a = \frac{\sigma_{\max} - \sigma_{\min}}{2} = \frac{(30 \text{ kpsi}) - (-10 \text{ kpsi})}{2} = \frac{40 \text{ kpsi}}{2} = 20 \text{ kpsi}$$

Step 4B. As the shear stress due to the torque is constant, the mean shear stress (τ_m) and alternating shear stress (τ_a) are

$$\tau_m = 8 \text{ kpsi}$$

$$\tau_a = 0 \text{ kpsi}$$

Step 5. Multiply the alternating normal stress (σ_a) by the reduced stress concentration factor (K_f) to give

$$\sigma_a = (1.15)(20 \text{ kpsi}) = 23 \text{ kpsi}$$

Step 6. There are no alternating axial stresses, so proceed to step 7.

Step 7. Calculate the two sets of principal stresses using Eqs. (7.36) and (7.37); one set for the mean normal and shear stresses and one set for the alternating normal and shear stresses.

$$\begin{aligned}\sigma_1^m, \sigma_2^m &= \frac{\sigma_m}{2} \pm \sqrt{\left(\frac{\sigma_m}{2}\right)^2 + \tau_m^2} = \frac{(10 \text{ kpsi})}{2} \pm \sqrt{\left(\frac{10 \text{ kpsi}}{2}\right)^2 + (8 \text{ kpsi})^2} \\ &= (5 \text{ kpsi}) \pm \sqrt{(25 + 64) \text{ kpsi}^2} = (5 \text{ kpsi}) \pm \sqrt{(89) \text{ kpsi}^2} \\ &= (5 \text{ kpsi}) \pm (9.4 \text{ kpsi}) = 14.4 \text{ kpsi}, -4.4 \text{ kpsi} \\ \sigma_1^a, \sigma_2^a &= \frac{\sigma_a}{2} \pm \sqrt{\left(\frac{\sigma_a}{2}\right)^2 + \tau_a^2} = \frac{(23 \text{ kpsi})}{2} \pm \sqrt{\left(\frac{23 \text{ kpsi}}{2}\right)^2 + (0 \text{ kpsi})^2} \\ &= (11.5 \text{ kpsi}) \pm \sqrt{(11.5 \text{ kpsi})^2} = (11.5 \text{ kpsi}) \pm (11.5 \text{ kpsi}) \\ &= 23 \text{ kpsi}, 0 \text{ kpsi}\end{aligned}$$

Step 8. Using Eqs. (7.38) and (7.39) calculate the effective mean stress and the effective alternating stress.

$$\begin{aligned}\sigma_m^{\text{eff}} &= \sqrt{(\sigma_1^m)^2 + (\sigma_2^m)^2 - (\sigma_1^m)(\sigma_2^m)} = \sqrt{(14.4)^2 + (-4.4)^2 - (14.4)(-4.4) \text{ kpsi}^2} \\ &= \sqrt{(207.36) + (19.36) + (63.36) \text{ kpsi}^2} = \sqrt{(290.08) \text{ kpsi}^2} \\ &= 17 \text{ kpsi} \\ \sigma_a^{\text{eff}} &= \sqrt{(\sigma_1^a)^2 + (\sigma_2^a)^2 - (\sigma_1^a)(\sigma_2^a)} = \sqrt{(23)^2 + (0)^2 - (23)(0) \text{ kpsi}^2} \\ &= 23 \text{ kpsi}\end{aligned}$$

Step 9A. Using Eq. (7.40) calculate the factor-of-safety (n) as

$$\begin{aligned}\frac{\sigma_a^{\text{eff}}}{S_e} + \frac{\sigma_m^{\text{eff}}}{S_{ut}} &= \frac{1}{n} = \frac{23 \text{ kpsi}}{28.8 \text{ kpsi}} + \frac{17 \text{ kpsi}}{75 \text{ kpsi}} = (0.799) + (0.227) = 1.026 \\ n &= \frac{1}{1.026} = 0.975 \text{ (unsafe!)}\end{aligned}$$

which as the factor-of-safety (n) is less than 1 means the design is unsafe.

Step 9B. Plot the mean effective stress (σ_m^{eff}) and alternating effective stress (σ_a^{eff}) from step 8, the given ultimate shear strength (S_{ut}), and the endurance limit (S_e) calculated in step 1F in a Goodman diagram like that shown in Fig. 7.31.

Notice that the point ($\sigma_m^{\text{eff}}, \sigma_a^{\text{eff}}$) is just outside the Goodman line, confirming the calculation in step 9A that the design is unsafe.

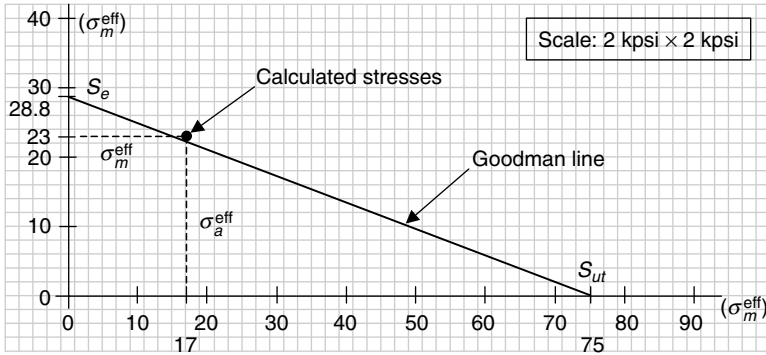

FIGURE 7.31 Goodman diagram for Example 1 (U.S. Customary).

SI/metric

Example 1. A circular shaft is acted upon by a combination of loadings: an applied torque that produces a constant shear stress of 56 MPa, an axial force that produces a constant normal stress of 70 MPa, and a bending moment that produces a completely reversed normal stress of ± 140 MPa. Determine the factor-of-safety (n) using the Goodman theory for combined loading.

The shaft is machined to a diameter of (2.5 cm) and has a keyway that results in a reduced stress concentration factor (K_f) equal to (1.15). The shaft operates at 100 °C. Also, the ultimate tensile strength (S_{ut}) is 525 MPa.

solution

Step 1A. Using Eq. (7.8) and values for the coefficient (a) and exponent (b) from Table 7.1, calculate the surface finish factor (k_a) as

$$k_a = a S_{ut}^b = (4.51 \text{ MPa}) (525 \text{ MPa})^{-0.265} = (4.51) (0.1902) = 0.86$$

Step 1B. Using Eq. (7.10) and the given diameter, calculate the size factor (k_b) as

$$k_b = \left(\frac{d}{7.62} \right)^{-0.1133} = \left(\frac{25}{7.62} \right)^{-0.1133} = (3.28)^{-0.1133} = 0.87$$

Step 1C. As required by the process, use the load type factor (k_c) for bending from Eq. (7.14) to be

$$k_c = 1$$

Step 1D. The shaft is operating at 100°C, so the temperature factor (k_d) from Eq. (7.15) and Table 7.2 is

$$k_d = 1.020$$

Step 1E. Using the given ultimate tensile stress (S_{ut}) and the guidelines in Eq. (7.1), calculate the test specimen endurance limit (S'_e) as

$$S'_e = 0.504 S_{ut} = (0.504) (525 \text{ MPa}) = 264.6 \text{ MPa}$$

Step 1F. Using the test specimen endurance limit (S'_e) found in step 1E, and the modifying factors found in steps 1A through 1D, calculate the endurance limit (S_e) for the solid shaft using the Marin equation for combined loading in Eq. (7.35) as

$$\begin{aligned} S_e &= k_a k_b (1) k_d S'_e = (0.86)(0.87)(1)(1.020) (264.6 \text{ MPa}) \\ &= (0.763)(264.6 \text{ MPa}) = 202 \text{ MPa} \end{aligned}$$

Step 2. The normal and shear stresses are given and displayed in Fig. 7.32.

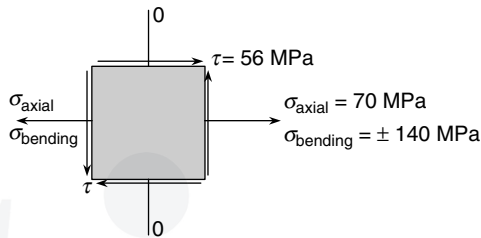

FIGURE 7.32 Plane stress element for Example 4 (SI/metric).

Step 3. Calculate the maximum normal stress (σ_{\max}) and the minimum normal stress (σ_{\min}) as

$$\sigma_{\max} = \sigma_{\text{axial}} + \sigma_{\text{bending}} = (70 \text{ MPa}) + (140 \text{ MPa}) = 210 \text{ MPa}$$

$$\sigma_{\min} = \sigma_{\text{axial}} - \sigma_{\text{bending}} = (70 \text{ MPa}) - (140 \text{ MPa}) = -70 \text{ MPa}$$

Step 4A. Calculate the mean normal stress (σ_m) and the alternating normal stress (σ_a) as

$$\sigma_m = \frac{\sigma_{\max} + \sigma_{\min}}{2} = \frac{(210 \text{ MPa}) + (-70 \text{ MPa})}{2} = \frac{140 \text{ MPa}}{2} = 70 \text{ MPa}$$

$$\sigma_a = \frac{\sigma_{\max} - \sigma_{\min}}{2} = \frac{(210 \text{ MPa}) - (-70 \text{ MPa})}{2} = \frac{280 \text{ MPa}}{2} = 140 \text{ MPa}$$

Step 4B. As the shear stress due to the torque is constant, the mean shear stress (τ_m) and alternating shear stress (τ_a) are

$$\tau_m = 56 \text{ MPa}$$

$$\tau_a = 0 \text{ MPa}$$

Step 5. Multiply the alternating normal stress (σ_a) by the reduced stress concentration factor (K_f) to give

$$\sigma_a = (1.15) (140 \text{ MPa}) = 161 \text{ MPa}$$

Step 6. There are no alternating axial stresses, so proceed to Step 7.

Step 7. Calculate the two sets of principal stresses using Eqs. (7.36) and (7.37); one set for the mean normal and shear stresses and one set for the alternating normal and shear stresses.

$$\begin{aligned}\sigma_1^m, \sigma_2^m &= \frac{\sigma_m}{2} \pm \sqrt{\left(\frac{\sigma_m}{2}\right)^2 + \tau_m^2} = \frac{(70 \text{ MPa})}{2} \pm \sqrt{\left(\frac{70 \text{ MPa}}{2}\right)^2 + (56 \text{ MPa})^2} \\ &= (25 \text{ MPa}) \pm \sqrt{(1,225 + 3,136) \text{ MPa}^2} = (35 \text{ MPa}) \pm \sqrt{(4,361) \text{ MPa}^2} \\ &= (35 \text{ MPa}) \pm (66 \text{ MPa}) = 101 \text{ MPa}, -31 \text{ MPa} \\ \sigma_1^a, \sigma_2^a &= \frac{\sigma_a}{2} \pm \sqrt{\left(\frac{\sigma_a}{2}\right)^2 + \tau_a^2} = \frac{(161 \text{ MPa})}{2} \pm \sqrt{\left(\frac{161 \text{ MPa}}{2}\right)^2 + (0 \text{ MPa})^2} \\ &= (80.5 \text{ MPa}) \pm \sqrt{(80.5 \text{ MPa})^2} = (80.5 \text{ MPa}) \pm (80.5 \text{ MPa}) \\ &= 161 \text{ MPa}, 0 \text{ MPa}\end{aligned}$$

Step 8. Using Eqs. (7.38) and (7.39) calculate the effective mean stress and the effective alternating stress.

$$\begin{aligned}\sigma_m^{\text{eff}} &= \sqrt{(\sigma_1^m)^2 + (\sigma_2^m)^2 - (\sigma_1^m)(\sigma_2^m)} = \sqrt{(101)^2 + (-31)^2 - (101)(-31) \text{ MPa}^2} \\ &= \sqrt{(10,201) + (961) + (3,131) \text{ MPa}^2} = \sqrt{(14,293) \text{ MPa}^2} \\ &= 120 \text{ MPa} \\ \sigma_a^{\text{eff}} &= \sqrt{(\sigma_1^a)^2 + (\sigma_2^a)^2 - (\sigma_1^a)(\sigma_2^a)} = \sqrt{(161)^2 + (0)^2 - (161)(0) \text{ MPa}^2} \\ &= 161 \text{ MPa}\end{aligned}$$

Step 9A. Using Eq. (7.40) calculate the factor-of-safety (n) as

$$\begin{aligned}\frac{\sigma_a^{\text{eff}}}{S_e} + \frac{\sigma_m^{\text{eff}}}{S_{ut}} &= \frac{1}{n} = \frac{161 \text{ MPa}}{202 \text{ MPa}} + \frac{120 \text{ MPa}}{525 \text{ MPa}} = (0.797) + (0.229) = 1.026 \\ n &= \frac{1}{1.026} = 0.975 \text{ (unsafe!)}\end{aligned}$$

which means the design is unsafe as the factor-of-safety n is less than 1.

Step 9B. Plot the mean effective stress (σ_m^{eff}) and alternating effective stress (σ_a^{eff}) from step 8, the given ultimate shear strength (S_{ut}), and the endurance limit (S_e) calculated in step 1F on a Goodman diagram like that shown in Fig. 7.33.

Notice that the point ($\sigma_m^{\text{eff}}, \sigma_a^{\text{eff}}$) is just outside the Goodman line, confirming the calculation in step 9A that the design is unsafe.

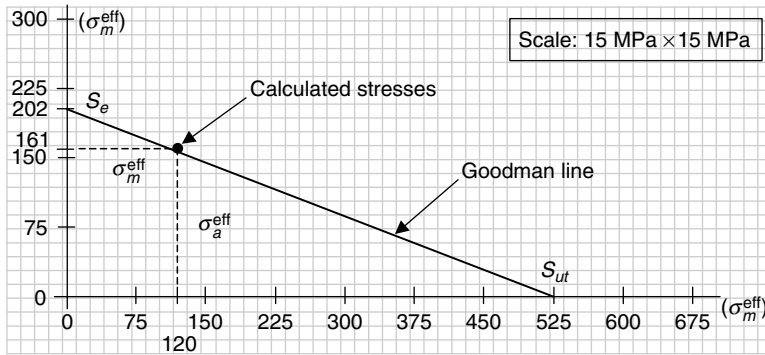

FIGURE 7.33 Goodman diagram for Example 1 (SI/metric).

This concludes Part I, Strength of Machines. Part II, Application to Machines, covers the most common types of machine elements, divided into three chapters. These three chapters represent the main themes of machine design:

1. Assembly
2. Energy
3. Motion

The principles and analysis methods, both mathematical and graphical, presented in the seven chapters of Part I will be used to determine the critical design parameters for these machine elements in Part II. These parameters will then be used to establish whether the design is safe under static or dynamic operating conditions.

P · A · R · T · 2

APPLICATION TO MACHINES





This page intentionally left blank.

CHAPTER 8

MACHINE ASSEMBLY

8.1 INTRODUCTION

In this chapter two important ways of connecting individual machine elements into an assembly will be discussed: bolted connections and welded connections. Both ways can be subjected to either static or dynamic conditions; therefore the safe design of both is important to the designer. Each type of connection will be discussed in detail with examples in both the U.S. Customary and SI/metric system of units.

Bolted connections are typically used when the assembly must allow for future access during service or repair, or when welded connections are not appropriate for the materials being assembled. Bolted connections are also used in permanent structural installations, where high-strength bolts are actually yielded during assembly to provide the maximum compressive joint, and therefore must be discarded if ever disassembled. Many bolted connections function in groups, where redundancy in the system is important.

In contrast, welded connections are appropriate when disassembly is not required, or when a weldment is more economical than a casting. For example, the advantages of a weldment design for use as a composite flywheel will be discussed in Chap. 9. In this chapter, welded connections under both static and dynamic loading conditions will be presented. Principles presented in many of the chapters of Part 1 will be applied extensively to weld joints carrying a variety of load types: axial, direct, torsion, bending, and combinations of these types.

8.2 BOLTED CONNECTIONS

As the overall theme of this book is to uncover the mystery of the formulas used in machine design for the practicing engineer, it will be assumed that the details of the nomenclature of cap screws, bolts, nuts, and washers, and the standard sizes and dimensions in both the U.S. Customary and SI/metric systems of units, is unnecessary. Therefore, the discussion will proceed directly to the first important topic, the fastener assembly itself, whether cap screw or bolt.

8.2.1 The Fastener Assembly

The fastener can either be a component of a bolt, two washers, and a nut assembly, or a component in a cap screw, single washer, and threaded hole assembly. In either case, the cap screw or bolt are under tension and the members being held together by the assembly, including the washers, are under compression. These two types of connections are shown in Fig. 8.1.

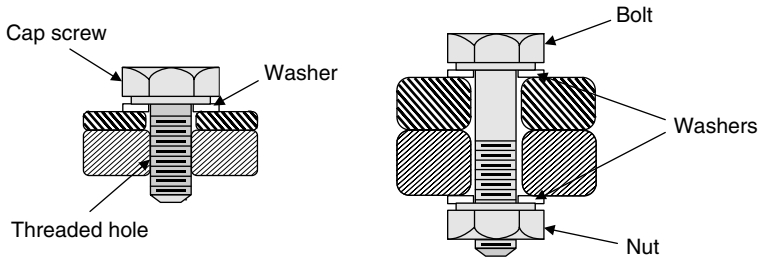

FIGURE 8.1 Bolt and cap screw connections.

One of the important design considerations is the stiffness, or spring rate, of the assembly, where insufficient stiffness will allow the joint to separate under load. Essentially, the cap screw or bolt acts as a linear spring, where the force (P) on the assembly is related to the change in length (δ) of the cap screw or bolt by the familiar spring force—deflection relationship given in Eq. 8.1.

$$P = k\delta \quad (8.1)$$

where (k) is the stiffness, or spring rate, and has units of force per unit length. Solving for the stiffness (k) in Eq. (8.1) gives

$$k = \frac{P}{\delta} \quad (8.2)$$

In the discussion on axial loading in Chap. 1, the change in length (δ) of a prismatic bar under a force (P) was given by Eq. (1.7), and repeated here

$$\delta = \frac{PL}{AE} \quad (1.7)$$

Where P = axial load on bar
 L = length of bar
 A = cross-sectional area of bar
 E = modulus of elasticity of bar material

Solving for (P/δ) in Eq. (1.7) gives

$$\frac{P}{\delta} = \frac{AE}{L} \quad (8.3)$$

Comparing Eqs. (8.2) and (8.3) gives the stiffness of a prismatic bar as

$$k = \frac{AE}{L} \quad (8.4)$$

For the cap screw, almost its entire length is threaded; therefore its stiffness is a single term given by Eq. (8.5) as

$$k_{\text{cap screw}} = \frac{A_T E}{L_T} \quad (8.5)$$

where (A_T) is the cross-sectional area of the threaded portion of the cap screw, which is also known as the tensile-stress area, and (L_T) is the length of the threaded portion that is equal to the thickness of the top member plus the thickness of the washer.

As for the bolt, part of its length is threaded and part of it is unthreaded. Therefore, its stiffness is the series combination of two separate stiffnesses; one for the threaded portion and one for the unthreaded portion, given by the following two relationships:

$$k_T = \frac{A_T E}{L_T} \quad (8.6)$$

$$k_{UT} = \frac{A_{UT} E}{L_{UT}} \quad (8.7)$$

where (A_T) and (L_T) are the threaded cross-sectional area and threaded length, respectively; and (A_{UT}) and (L_{UT}) are the unthreaded cross-sectional area and unthreaded length, respectively, of the bolt. The two lengths (L_T) and (L_{UT}) must add up to the thickness of the members plus the thickness of the washers, not the total length of the bolt. The unthreaded cross-sectional area (A_{UT}) is found using the major diameter of the bolt. If a cap screw has a significant unthreaded length, then treat its stiffness like a bolt.

The two stiffnesses given in Eqs. (8.6) and (8.7) act in series; therefore the overall stiffness of the bolt is given by Eq. (8.8) as

$$\frac{1}{k_{\text{bolt}}} = \frac{1}{k_T} + \frac{1}{k_{UT}} \quad (8.8)$$

which can be rearranged as

$$k_{\text{bolt}} = \frac{k_T k_{UT}}{k_T + k_{UT}} \quad (8.9)$$

Note that if one of the stiffnesses is very different from the other, it will dominate the overall stiffness. Also, use Eq. (8.9) for a cap screw with an unthreaded length.

As mentioned above, the threaded and unthreaded lengths, (L_T) and (L_{UT}), do not add up to the total length (L_{total}) of the threaded and unthreaded portions of a cap screw or bolt. They add up to what is called the *grip*, which is the thickness of the unthreaded members plus the thickness of the washers. This relationship is given in Eq. (8.10) as

$$L_{\text{grip}} = L_{\substack{\text{unthreaded} \\ \text{members}}} + L_{\text{washers}} = L_{UT} + L_T \quad (8.10)$$

For a cap screw assembly, one member is threaded. For a nut and bolt assembly, none of the members is threaded. Also, washers are recommended to avoid stress concentrations on the cap screw, bolt, or nut from the sharp edges of machined holes; however, they must be hardened so as not to compromise the stiffness of the joint, which will be discussed in the next section. Washers should be installed with the rounded stamped side facing the cap screw or bolt head, or the washer face of the nut.

The total length (L_{total}) of a cap screw can therefore be separated into three lengths as given by Eq. (8.11).

$$L_{\text{total}} = L_{\text{grip}} + L_{\text{hole}} + L_{\text{extra}} \quad (8.11)$$

where the grip length (L_{grip}) may only be the threaded length (L_T), and where (L_{hole}) is the length of the cap screw in the threaded hole, and (L_{extra}) is the extra length of the cap screw past the threaded hole, if any. Cap screws may have a short unthreaded length.

Similarly, the total length (L_{total}) of a nut and bolt assembly can be separated into three lengths as given by Eq. (8.12).

$$L_{\text{total}} = L_{\text{grip}} + L_{\text{nut}} + L_{\text{extra}} \quad (8.12)$$

where the grip length (L_{grip}) is the sum of two lengths, (L_T) and (L_{UT}), as given in Eq. (8.10), and where (L_{nut}) is the full length of the nut, and (L_{extra}) is the extra length of the bolt past the nut that typically should be one to two threads after tightening.

However, the actual threaded length of the bolt (L_{threaded}) is also the sum of three lengths, given by Eq. (8.13) as

$$L_{\text{threaded}} = L_T + L_{\text{nut}} + L_{\text{extra}} \quad (8.13)$$

or solving for the threaded length (L_T) needed to determine the stiffness of the threaded length (k_T) from Eq. (8.6) gives

$$L_T = L_{\text{threaded}} - (L_{\text{nut}} + L_{\text{extra}}) \quad (8.14)$$

Using Eq. (8.12), the sum (L_{nut}) plus (L_{extra}) in Eq. (8.14) can be replaced with

$$L_{\text{nut}} + L_{\text{extra}} = L_{\text{total}} - L_{\text{grip}} \quad (8.15)$$

so that the threaded length (L_T) becomes

$$\begin{aligned} L_T &= L_{\text{threaded}} - (L_{\text{total}} - L_{\text{grip}}) \\ &= L_{\text{threaded}} - L_{\text{total}} + L_{\text{grip}} \end{aligned} \quad (8.16)$$

Therefore, solving for the unthreaded length of the bolt (L_{UT}) in Eq. (8.10), needed to determine the stiffness of the unthreaded length (k_{UT}) from Eq. (8.7), gives

$$L_{UT} = L_{\text{grip}} - L_T \quad (8.17)$$

where the grip length (L_{grip}) will be known from the design drawings, and the total length (L_{total}) and threaded length (L_{threaded}) of the bolt can be found from standard references such as *Marks' Standard Handbook for Mechanical Engineers*.

Also, the threaded cross-sectional area (A_T), which is the tensile-stress area, would be found in these same standard references, such as Marks', whereas the unthreaded cross-sectional area (A_{UT}) would be simply calculated using the nominal bolt diameter.

Consider the following example for a bolted connection like that shown in Fig. 8.1, except that no washers are used.

U.S. Customary	SI/Metric
<p>Example 1. Determine the stiffness of a high-strength diameter steel bolt and nut assembly, with no installed washers, where</p> $\begin{aligned} d_{\text{bolt}} &= 0.5 \text{ in (nominal)} \\ L_{\text{total}} &= 2.5 \text{ in} \\ L_{\text{threaded}} &= 1.25 \text{ in} \\ L_{\text{grip}} &= 1.75 \text{ in} \\ A_T &= 0.142 \text{ in}^2 = 1.42 \times 10^{-1} \text{ in}^2 \\ E &= 30 \times 10^6 \text{ lb/in}^2 \end{aligned}$	<p>Example 1. Determine the stiffness of a high-strength diameter steel bolt and nut assembly, with no installed washers, where</p> $\begin{aligned} d_{\text{bolt}} &= 12 \text{ mm} = 0.012 \text{ m (nominal)} \\ L_{\text{total}} &= 60 \text{ mm} = 0.06 \text{ m} \\ L_{\text{threaded}} &= 30 \text{ mm} = 0.03 \text{ m} \\ L_{\text{grip}} &= 45 \text{ mm} = 0.045 \text{ m} \\ A_T &= 84.3 \text{ mm}^2 = 8.43 \times 10^{-5} \text{ m}^2 \\ E &= 207 \text{ GPa} = 207 \times 10^9 \text{ N/m}^2 \end{aligned}$

U.S. Customary	SI/Metric
<p>solution</p> <p><i>Step 1.</i> Using Eq. (8.16), calculate the threaded length (L_T) as</p> $\begin{aligned} L_T &= L_{\text{threaded}} - L_{\text{total}} + L_{\text{grip}} \\ &= (1.25 \text{ in}) - (2.5 \text{ in}) + (1.75 \text{ in}) \\ &= 0.5 \text{ in} \end{aligned}$ <p><i>Step 2.</i> Using Eq. (8.17), calculate the unthreaded length (L_{UT}) as</p> $\begin{aligned} L_{UT} &= L_{\text{grip}} - L_T \\ &= (1.75 \text{ in}) - (0.5 \text{ in}) \\ &= 1.25 \text{ in} \end{aligned}$ <p><i>Step 3.</i> Using the nominal bolt diameter, calculate the unthreaded cross-sectional area (A_{UT}) as</p> $\begin{aligned} A_{UT} &= \frac{\pi d_{\text{bolt}}^2}{4} \\ &= \frac{\pi(0.5 \text{ in})^2}{4} \\ &= 1.96 \times 10^{-1} \text{ in}^2 \end{aligned}$ <p><i>Step 4.</i> Using the threaded length (L_T) found in step 1, the given threaded cross-sectional area (A_T), and the modulus of elasticity (E), calculate the threaded stiffness (k_T) using Eq. (8.6) as</p> $\begin{aligned} k_T &= \frac{A_T E}{L_T} \\ &= \frac{(1.42 \times 10^{-1} \text{ in}^2)(30 \times 10^6 \text{ lb/in}^2)}{(0.5 \text{ in})} \\ &= 8.52 \times 10^6 \text{ lb/in} \end{aligned}$ <p><i>Step 5.</i> Using the unthreaded length (L_{UT}) found in step 2, the unthreaded cross-sectional area (A_{UT}) found in step 3, and the modulus of elasticity (E), calculate the unthreaded stiffness (k_{UT}) using Eq. (8.7) as</p> $\begin{aligned} k_{UT} &= \frac{A_{UT} E}{L_{UT}} \\ &= \frac{(1.96 \times 10^{-1} \text{ in}^2)(30 \times 10^6 \text{ lb/in}^2)}{(1.25 \text{ in})} \\ &= 4.70 \times 10^6 \text{ lb/in} \end{aligned}$	<p>solution</p> <p><i>Step 1.</i> Using Eq. (8.16), calculate the threaded length (L_T) as</p> $\begin{aligned} L_T &= L_{\text{threaded}} - L_{\text{total}} + L_{\text{grip}} \\ &= (0.03 \text{ m}) - (0.06 \text{ m}) + (0.045 \text{ m}) \\ &= 0.015 \text{ m} \end{aligned}$ <p><i>Step 2.</i> Using Eq. (8.17), calculate the unthreaded length (L_{UT}) as</p> $\begin{aligned} L_{UT} &= L_{\text{grip}} - L_T \\ &= (0.045 \text{ m}) - (0.015 \text{ m}) \\ &= 0.03 \text{ m} \end{aligned}$ <p><i>Step 3.</i> Using the nominal bolt diameter, calculate the unthreaded cross-sectional area (A_{UT}) as</p> $\begin{aligned} A_{UT} &= \frac{\pi d_{\text{bolt}}^2}{4} \\ &= \frac{\pi(0.012 \text{ m})^2}{4} \\ &= 1.13 \times 10^{-4} \text{ m}^2 \end{aligned}$ <p><i>Step 4.</i> Using the threaded length (L_T) found in step 1, the given threaded cross-sectional area (A_T), and the modulus of elasticity (E), calculate the threaded stiffness (k_T) using Eq. (8.6) as</p> $\begin{aligned} k_T &= \frac{A_T E}{L_T} \\ &= \frac{(8.43 \times 10^{-5} \text{ m}^2)(207 \times 10^9 \text{ N/m}^2)}{(0.015 \text{ m})} \\ &= 1.16 \times 10^9 \text{ N/m} \end{aligned}$ <p><i>Step 5.</i> Using the unthreaded length (L_{UT}) found in step 2, the unthreaded cross-sectional area (A_{UT}) found in step 3, and the modulus of elasticity (E), calculate the unthreaded stiffness (k_{UT}) using Eq. (8.7) as</p> $\begin{aligned} k_{UT} &= \frac{A_{UT} E}{L_{UT}} \\ &= \frac{(1.13 \times 10^{-4} \text{ m}^2)(207 \times 10^9 \text{ N/m}^2)}{(0.03 \text{ m})} \\ &= 7.80 \times 10^8 \text{ N/m} \end{aligned}$

U.S. Customary	SI/Metric
<p><i>Step 6.</i> Using the threaded stiffness (k_T) found in step 4 and the unthreaded stiffness (k_{UT}) found in step 5, calculate the bolt stiffness (k_{bolt}) using Eq. (8.9) as</p> $k_{\text{bolt}} = \frac{k_T k_{UT}}{k_T + k_{UT}}$ $= \frac{(8.52 \times 10^6)(4.70 \times 10^6) \text{ lb}^2/\text{in}^2}{(8.52 \times 10^6) + (4.70 \times 10^6) \text{ lb/in}}$ $= \frac{4.00 \times 10^{13} \text{ lb}^2/\text{in}^2}{1.32 \times 10^7 \text{ lb/in}}$ $= 3.03 \times 10^6 \text{ lb/in}$ $= 3,030 \text{ kip/in}$	<p><i>Step 6.</i> Using the threaded stiffness (k_T) found in step 4 and the unthreaded stiffness (k_{UT}) found in step 5, calculate the bolt stiffness (k_{bolt}) using Eq. (8.9) as</p> $k_{\text{bolt}} = \frac{k_T k_{UT}}{k_T + k_{UT}}$ $= \frac{(1.16 \times 10^9)(7.80 \times 10^8) \text{ N}^2/\text{m}^2}{(1.16 \times 10^9) + (7.80 \times 10^8) \text{ N/m}}$ $= \frac{9.05 \times 10^{17} \text{ N}^2/\text{m}^2}{1.94 \times 10^9 \text{ N/m}}$ $= 4.66 \times 10^8 \text{ N/m}$ $= 466 \text{ MN/m}$

8.2.2 The Members

As stated earlier, the members in a bolted connection, including any washers, are under compression, and they too act as linear springs. Therefore, the expression for the series combination of the threaded and unthreaded stiffnesses given in Eq. (8.8) can be extended to allow for more than two member stiffnesses as given in Eq. (8.18) as

$$\frac{1}{k_{\text{members}}} = \frac{1}{k_1} + \frac{1}{k_2} + \frac{1}{k_3} + \cdots + \frac{1}{k_N} \quad (8.18)$$

where (N) is the number of members in the joint.

If one of the members within the joint is a gasket, which usually has a significantly lower stiffness than the other members, then it will dominate the overall stiffness of the joint in a negative way. For this reason gaskets should never be used in a structural joint, one that is primarily carrying high loads. This is in contrast to joints that are merely sealing off a gas or a liquid in a tank or pipeline. However, if both strength and sealing are important, such as in pressure vessel applications, then special designs are needed to provide the necessary sealing without compromising the stiffness of the joint.

The stiffness of a member in compression is not as straightforward as was the case for a cap screw or bolt in tension. Much research has been conducted and is continuing. The most accepted of the theories currently in practice proposes that the distribution of pressure in the members spreads out from under the washer face of the bolt and the washer face of the nut in a volume resembling the frustum of a hollow cone. The geometry and notation for this theory is shown in Fig. 8.2.

Note that the hollow frustum from the washer face of the bolt and the hollow frustum from the washer face of the nut meet at the midpoint of the grip. As the thicknesses of the two members (t_1) and (t_2) shown in Fig. 8.2 are not equal, there is a third thickness in the middle, denoted by (t_{middle}), and given by Eq. (8.19) as

$$t_{\text{middle}} = t_2 - \left(\frac{L_{\text{grip}}}{2} \right) - t_{\text{washer}} \quad (8.19)$$

Therefore, there are actually five hollow frusta that act as linear springs; one for each washer, two in the member with the greater thickness, and one in the other member.

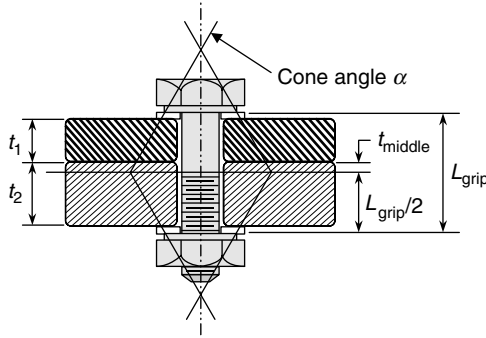

FIGURE 8.2 Pressure distribution as frusta of hollow cones.

Without presenting the details of its development, which includes the integration of a very complex integral, the stiffness of a frustum of a hollow cone (k_{frustum}) is given by Eq. (8.20) as

$$k_{\text{frustum}} = \frac{(\pi \tan \alpha) E d}{\ln \left[\frac{(2t \tan \alpha + D - d)(D + d)}{(2t \tan \alpha + D + d)(D - d)} \right]} \quad (8.20)$$

where (α) is the cone angle of the frustum, (E) is the modulus of elasticity of the member, (d) is the nominal diameter of the bolt, or cap screw, and (D) is the diameter of the washer face. As stated earlier, if the members have different thicknesses, there will be a third thickness (t_{middle}), for which the diameter (D) will be the smaller of the two diameters of the frustum. This special diameter (D^*) for the third thickness (t_{middle}) can be found from Eq. (8.21) as

$$D^* = D + (L_{\text{grip}} - 2 t_{\text{middle}}) \tan \alpha \quad (8.21)$$

Current practice sets the cone angle (α) equal to 30° , and the standard washer face diameter (D) for both the bolt and nut is equal to one and a half times the nominal diameter of the bolt, that is ($D = 1.5d$).

Therefore, the frustum stiffness (k_{frustum}) given in Eq. (8.20) becomes the expression given in Eq. (8.22)

$$k_{\text{frustum}} = \frac{(\pi \tan 30^\circ) E d}{\ln \left[5 \frac{2t \tan 30^\circ + 0.5d}{2t \tan 30^\circ + 2.5d} \right]} \quad (8.22)$$

where again (d) is the nominal diameter of the bolt, or cap screw, and (t) is the thickness of the frustum. Also, the special diameter (D^*) given in Eq. (8.21) becomes

$$D^* = 1.5d + (L_{\text{grip}} - 2 t_{\text{middle}}) \tan 30^\circ \quad (8.23)$$

Once calculated, the stiffness of each frustum is then used in Eq. (8.18) to determine the overall stiffness of the members (k_{members}).

In Example 1, the length of the grip (L_{grip}) was given, but not the individual thicknesses of the two members. Example 2 determines the overall stiffnesses of members in an assembly when there is a third thickness (t_{middle}) resulting in three hollow cone frusta.

U.S. Customary	SI/Metric
<p>Example 2. Determine the stiffness of the members in a bolted assembly, with no installed washers, where</p> $d_{\text{bolt}} = 0.5 \text{ in (nominal)}$ $D = 1.5 d_{\text{bolt}} \text{ (washer face)}$ $\alpha = 30^\circ \text{ (cone angle)}$ $L_{\text{grip}} = 1.75 \text{ in}$ $t_1 = 0.75 \text{ in (steel)}$ $t_2 = 1 \text{ in (cast iron)}$ $E_1 = 30 \times 10^6 \text{ lb/in}^2$ $E_2 = 16 \times 10^6 \text{ lb/in}^2$ <p>solution</p> <p><i>Step 1.</i> As the thicknesses (t_1) and (t_2) are not equal, a third thickness (t_{middle}) is found from Eq. (8.19) as</p> $t_{\text{middle}} = t_2 - \left(\frac{L_{\text{grip}}}{2} \right) - t_{\text{washer}}$ $= (1 \text{ in}) - \left(\frac{1.75 \text{ in}}{2} \right) - (0 \text{ in})$ $= 0.125 \text{ in}$ <p><i>Step 2.</i> Using the third thickness (t_{middle}) found in step 1 in Eq. (8.23), calculate the special diameter (D^*) as</p> $D^* = 1.5 d + (L_{\text{grip}} - 2 t_{\text{middle}}) \tan 30^\circ$ $= (1.5)(0.5 \text{ in})$ $+ (1.75 \text{ in} - 2 (0.125 \text{ in}))(0.577)$ $= (0.75 \text{ in}) + (1.5 \text{ in})(0.577)$ $= 1.62 \text{ in}$ <p><i>Step 3.</i> Substitute the special diameter (D^*) found in step 2, the third thickness (t_{middle}) found in step 1, and the given cone angle (α) and modulus of elasticity (E_2), in Eq. (8.20) to find the stiffness (k_{middle}) as</p> $k_{\text{middle}} = \frac{(\pi \tan \alpha) Ed}{\ln \left[\frac{(2t \tan \alpha + D - d)(D + d)}{(2t \tan \alpha + D + d)(D - d)} \right]}$ $= \frac{(\pi \tan 30^\circ) E_2 d_{\text{bolt}}}{\ln \left[\frac{C_1}{C_2} \right]}$	<p>Example 2. Determine the stiffness of the members in a bolted assembly, with no installed washers, where</p> $d_{\text{bolt}} = 12 \text{ mm} = 0.012 \text{ m (nominal)}$ $D = 1.5 d_{\text{bolt}} \text{ (washer face)}$ $\alpha = 30^\circ \text{ (cone angle)}$ $L_{\text{grip}} = 45 \text{ mm} = 0.045 \text{ m}$ $t_1 = 20 \text{ mm} = 0.02 \text{ m (steel)}$ $t_2 = 25 \text{ mm} = 0.025 \text{ m (cast iron)}$ $E_1 = 207 \text{ GPa} = 207 \times 10^9 \text{ N/m}^2$ $E_2 = 110 \text{ GPa} = 110 \times 10^9 \text{ N/m}^2$ <p>solution</p> <p><i>Step 1.</i> As the thicknesses (t_1) and (t_2) are not equal, a third thickness (t_{middle}) is found from Eq. (8.19) as</p> $t_{\text{middle}} = t_2 - \left(\frac{L_{\text{grip}}}{2} \right) - t_{\text{washer}}$ $= (0.025 \text{ m}) - \left(\frac{0.045}{2} \text{ m} \right) - (0 \text{ m})$ $= 0.0025 \text{ m}$ <p><i>Step 2.</i> Using the third thickness (t_{middle}) found in step 1 in Eq. (8.23), calculate the special diameter (D^*) as</p> $D^* = 1.5 d + (L_{\text{grip}} - 2 t_{\text{middle}}) \tan 30^\circ$ $= (1.5)(0.012 \text{ m})$ $+ (0.045 \text{ m} - 2 (0.0025 \text{ m}))(0.577)$ $= (0.018 \text{ m}) + (0.040 \text{ m})(0.577)$ $= 0.041 \text{ m}$ <p><i>Step 3.</i> Substitute the special diameter (D^*) found in step 2, the third thickness (t_{middle}) found in step 1, and the given cone angle (α) and modulus of elasticity (E_2), in Eq. (8.20) to find the stiffness (k_{middle}) as</p> $k_{\text{middle}} = \frac{(\pi \tan \alpha) Ed}{\ln \left[\frac{(2t \tan \alpha + D - d)(D + d)}{(2t \tan \alpha + D + d)(D - d)} \right]}$ $= \frac{(\pi \tan 30^\circ) E_2 d_{\text{bolt}}}{\ln \left[\frac{C_1}{C_2} \right]}$

U.S. Customary	SI/Metric
where	where
$C_1 = (2t \tan \alpha + D - d)(D + d)$ $= (2t_{\text{middle}} \tan 30^\circ + D^* - d_{\text{bolt}})$ $\times (D^* + d_{\text{bolt}})$ $= \left((2)(0.125 \text{ in})(0.577) \right)$ $+ (1.62 \text{ in}) - (0.5 \text{ in})$ $\times ((1.62 \text{ in}) + (0.5 \text{ in}))$ $= (1.26 \text{ in})(2.12 \text{ in})$ $= 2.68 \text{ in}^2$	$C_1 = (2t \tan \alpha + D - d)(D + d)$ $= (2t_{\text{middle}} \tan 30^\circ + D^* - d_{\text{bolt}})$ $\times (D^* + d_{\text{bolt}})$ $= \left((2)(0.0025 \text{ m})(0.577) \right)$ $+ (0.041 \text{ m}) - (0.012 \text{ m})$ $\times ((0.041 \text{ m}) + (0.012 \text{ m}))$ $= (0.032 \text{ m})(0.053 \text{ m})$ $= 0.00170 \text{ m}^2$
and	and
$C_2 = (2t \tan \alpha + D + d)(D - d)$ $= (2t_{\text{middle}} \tan 30^\circ + D^* + d_{\text{bolt}})$ $\times (D^* - d_{\text{bolt}})$ $= \left((2)(0.125 \text{ in})(0.577) \right)$ $+ (1.62 \text{ in}) + (0.5 \text{ in})$ $\times ((1.62 \text{ in}) - (0.5 \text{ in}))$ $= (2.26 \text{ in})(1.12 \text{ in})$ $= 2.54 \text{ in}^2$	$C_2 = (2t \tan \alpha + D + d)(D - d)$ $= (2t_{\text{middle}} \tan 30^\circ + D^* + d_{\text{bolt}})$ $\times (D^* - d_{\text{bolt}})$ $= \left((2)(0.0025 \text{ m})(0.577) \right)$ $+ (0.041 \text{ m}) + (0.012 \text{ m})$ $\times ((0.041 \text{ m}) - (0.012 \text{ m}))$ $= (0.056 \text{ m})(0.029 \text{ m})$ $= 0.00162 \text{ m}^2$
Therefore,	Therefore,
$k_{\text{middle}} = \frac{(1.814) \left(16 \times 10^6 \frac{\text{lb}}{\text{in}^2} \right) (0.5 \text{ in})}{\ln \left[\frac{2.68 \text{ in}^2}{2.54 \text{ in}^2} \right]}$ $= \frac{1.45 \times 10^7 \text{ lb/in}}{0.054}$ $= 2.69 \times 10^8 \text{ lb/in}$	$k_{\text{middle}} = \frac{(1.814) \left(1.1 \times 10^{11} \frac{\text{N}}{\text{m}^2} \right) (0.012 \text{ m})}{\ln \left[\frac{0.00170 \text{ m}^2}{0.00162 \text{ m}^2} \right]}$ $= \frac{2.39 \times 10^9 \text{ N/m}}{0.048}$ $= 4.98 \times 10^{10} \text{ N/m}$
<p><i>Step 4.</i> The remaining thickness of the cast iron member is the thickness (t_2) minus the third thickness (t_{middle}), which from Eq. (8.19) is half the grip length ($L_{\text{grip}}/2$). Substitute this remaining thickness ($L_{\text{grip}}/2$), the given bolt diameter (d_{bolt}), and the modulus of elasticity (E_2) in Eq. (8.22) to find the stiffness (k_2) as</p>	<p><i>Step 4.</i> The remaining thickness of the cast iron member is the thickness (t_2) minus the third thickness (t_{middle}), which from Eq. (8.19) is half the grip length ($L_{\text{grip}}/2$). Substitute this remaining thickness ($L_{\text{grip}}/2$), the given bolt diameter (d_{bolt}), and the modulus of elasticity (E_2) in Eq. (8.22) to find the stiffness (k_2) as</p>
$k_2 = \frac{(\pi \tan 30^\circ) Ed}{\ln \left[5 \frac{2t \tan 30^\circ + 0.5d}{2t \tan 30^\circ + 2.5d} \right]}$ $= \frac{(\pi \tan 30^\circ) E_2 d_{\text{bolt}}}{\ln \left[5 \frac{C_1}{C_2} \right]}$	$k_2 = \frac{(\pi \tan 30^\circ) Ed}{\ln \left[5 \frac{2t \tan 30^\circ + 0.5d}{2t \tan 30^\circ + 2.5d} \right]}$ $= \frac{(\pi \tan 30^\circ) E_2 d_{\text{bolt}}}{\ln \left[5 \frac{C_1}{C_2} \right]}$

U.S. Customary	SI/Metric
<p>where</p> $C_1 = 2t \tan 30^\circ + 0.5d$ $= 2(L_{\text{grip}}/2) \tan 30^\circ + 0.5d_{\text{bolt}}$ $= 2(1.75 \text{ in}/2) \tan 30^\circ + 0.5(0.5 \text{ in})$ $= 1.26 \text{ in}$ <p>and</p> $C_2 = 2t \tan 30^\circ + 2.5d$ $= 2(L_{\text{grip}}/2) \tan 30^\circ + 2.5d_{\text{bolt}}$ $= 2(1.75 \text{ in}/2) \tan 30^\circ + 2.5(0.5 \text{ in})$ $= 2.26 \text{ in}$ <p>Therefore,</p> $k_2 = \frac{(1.814) \left(16 \times 10^6 \frac{\text{lb}}{\text{in}^2} \right) (0.5 \text{ in})}{\ln \left[5 \frac{1.26 \text{ in}}{2.26 \text{ in}} \right]}$ $= \frac{1.45 \times 10^7 \text{ lb/in}}{1.025}$ $= 1.42 \times 10^7 \text{ lb/in}$ <p><i>Step 5.</i> Substitute the thickness (t_1), the bolt diameter (d_{bolt}), and the modulus of elasticity (E_1) in Eq. (8.22) to find the stiffness (k_1) as</p> $k_1 = \frac{(\pi \tan 30^\circ) Ed}{\ln \left[5 \frac{2t \tan 30^\circ + 0.5d}{2t \tan 30^\circ + 2.5d} \right]}$ $= \frac{(\pi \tan 30^\circ) E_1 d_{\text{bolt}}}{\ln \left[5 \frac{C_1}{C_2} \right]}$ <p>where</p> $C_1 = 2t \tan 30^\circ + 0.5d$ $= 2t_1 \tan 30^\circ + 0.5d_{\text{bolt}}$ $= 2(0.75 \text{ in}) \tan 30^\circ + 0.5(0.5 \text{ in})$ $= 1.17 \text{ in}$ <p>and</p> $C_2 = 2t \tan 30^\circ + 2.5d$ $= 2t_1 \tan 30^\circ + 2.5d_{\text{bolt}}$ $= 2(0.75 \text{ in}) \tan 30^\circ + 2.5(0.5 \text{ in})$ $= 2.17 \text{ in}$	<p>where</p> $C_1 = 2t \tan 30^\circ + 0.5d$ $= 2(L_{\text{grip}}/2) \tan 30^\circ + 0.5d_{\text{bolt}}$ $= 2(0.045 \text{ m}/2) \tan 30^\circ + 0.5(.012 \text{ m})$ $= 0.032 \text{ m}$ <p>and</p> $C_2 = 2t \tan 30^\circ + 2.5d$ $= 2(L_{\text{grip}}/2) \tan 30^\circ + 2.5d_{\text{bolt}}$ $= 2(0.045 \text{ m}/2) \tan 30^\circ + 2.5(.012 \text{ m})$ $= 0.056 \text{ m}$ <p>Therefore,</p> $k_2 = \frac{(1.814) \left(1.1 \times 10^{11} \frac{\text{N}}{\text{m}^2} \right) (.012 \text{ m})}{\ln \left[5 \frac{0.032 \text{ m}}{0.056 \text{ m}} \right]}$ $= \frac{2.39 \times 10^9 \text{ N/m}}{1.05}$ $= 2.28 \times 10^9 \text{ N/m}$ <p><i>Step 5.</i> Substitute the thickness (t_1), the bolt diameter (d_{bolt}), and the modulus of elasticity (E_1) in Eq. (8.22) to find the stiffness (k_1) as</p> $k_1 = \frac{(\pi \tan 30^\circ) Ed}{\ln \left[5 \frac{2t \tan 30^\circ + 0.5d}{2t \tan 30^\circ + 2.5d} \right]}$ $= \frac{(\pi \tan 30^\circ) E_1 d_{\text{bolt}}}{\ln \left[5 \frac{C_1}{C_2} \right]}$ <p>where</p> $C_1 = 2t \tan 30^\circ + 0.5d$ $= 2t_1 \tan 30^\circ + 0.5d_{\text{bolt}}$ $= 2(0.02 \text{ m}) \tan 30^\circ + 0.5(.012 \text{ m})$ $= 0.029 \text{ m}$ <p>and</p> $C_2 = 2t \tan 30^\circ + 2.5d$ $= 2t_1 \tan 30^\circ + 2.5d_{\text{bolt}}$ $= 2(0.02 \text{ m}) \tan 30^\circ + 2.5(.012 \text{ m})$ $= 0.053 \text{ m}$

U.S. Customary	SI/Metric
<p>Therefore,</p> $k_1 = \frac{(1.814) \left(30 \times 10^6 \frac{\text{lb}}{\text{in}^2} \right) (0.5 \text{ in})}{\ln \left[5 \frac{1.17 \text{ in}}{2.17 \text{ in}} \right]}$ $= \frac{2.72 \times 10^7 \text{ lb/in}}{0.992}$ $= 2.74 \times 10^7 \text{ lb/in}$ <p><i>Step 6.</i> Substitute the middle stiffness (k_{middle}) found in step 3, the stiffness (k_2) found in step 4, and the stiffness (k_1) found in step 5 in Eq. (8.18) to determine the overall stiffness of the members (k_{members}) as</p> $\frac{1}{k_{\text{members}}} = \frac{1}{k_1} + \frac{1}{k_2} + \frac{1}{k_{\text{middle}}}$ $= \frac{1}{2.74 \times 10^7 \text{ lb/in}} + \frac{1}{1.42 \times 10^7 \text{ lb/in}} + \frac{1}{2.69 \times 10^8 \text{ lb/in}}$ $= \left(\begin{array}{l} 3.65 \times 10^{-8} \\ +7.04 \times 10^{-8} \\ +3.72 \times 10^{-9} \end{array} \right) \frac{\text{in}}{\text{lb}}$ $= 1.106 \times 10^{-7} \text{ in/lb}$ <p>Therefore,</p> $k_{\text{members}} = \frac{1}{1.106 \times 10^{-7} \text{ in/lb}}$ $= 9.04 \times 10^6 \text{ lb/in}$ $= 9,040 \text{ kip/in}$	<p>Therefore,</p> $k_1 = \frac{(1.814) \left(2.07 \times 10^{11} \frac{\text{N}}{\text{m}^2} \right) (.012 \text{ m})}{\ln \left[5 \frac{0.029 \text{ m}}{0.053 \text{ m}} \right]}$ $= \frac{4.51 \times 10^9 \text{ N/m}}{1.006}$ $= 4.48 \times 10^9 \text{ N/m}$ <p><i>Step 6.</i> Substitute the middle stiffness (k_{middle}) found in step 3, the stiffness (k_2) found in step 4, and the stiffness (k_1) found in step 5 in Eq. (8.18) to determine the overall stiffness of the members (k_{members}) as</p> $\frac{1}{k_{\text{members}}} = \frac{1}{k_1} + \frac{1}{k_2} + \frac{1}{k_{\text{middle}}}$ $= \frac{1}{4.48 \times 10^9 \text{ N/m}} + \frac{1}{2.28 \times 10^9 \text{ N/m}} + \frac{1}{4.98 \times 10^{10} \text{ N/m}}$ $= \left(\begin{array}{l} 2.23 \times 10^{-10} \\ +4.39 \times 10^{-10} \\ +2.01 \times 10^{-11} \end{array} \right) \frac{\text{m}}{\text{N}}$ $= 6.821 \times 10^{-10} \text{ m/N}$ <p>Therefore,</p> $k_{\text{members}} = \frac{1}{6.821 \times 10^{-10} \text{ m/N}}$ $= 1.47 \times 10^9 \text{ N/m}$ $= 1,470 \text{ MN/m}$

Note that the stiffness of the members found in Example 2 is about three times the stiffness of the bolt found in Example 1. Also, the stiffness (k_{middle}) could have been neglected as it was over ten times the stiffness (k_1) and over 20 times the stiffness (k_2). Remember, in a series combination of stiffnesses, the lowest stiffness governs, not the highest.

8.2.3 Bolt Strength and Preload

The bolt strength, denoted by (S_{proof}), is the *proof load*, denoted by (F_{proof}), divided by the tensile-stress area (A_T) and given in Eq. (8.24) as

$$S_{\text{proof}} = \frac{F_{\text{proof}}}{A_T} \quad (8.24)$$

or rearranging gives

$$F_{\text{proof}} = S_{\text{proof}} A_T \quad (8.25)$$

The proof strength (S_{proof}) is the maximum allowable stress in the bolt before a permanent set is developed. This occurs at approximately 90 percent of the yield strength (S_y) of the bolt material. Values for the quantities in Eqs. (8.24) and (8.25) are available in references, such as *Marks' Standard Handbook for Mechanical Engineers*. If the proof strength is not available, then use a value of 85 percent of the yield strength of the material.

The stress-strain diagram for a typical high-strength bolt, or cap screw, which is considered to be a brittle material, is shown in Fig. 8.3.

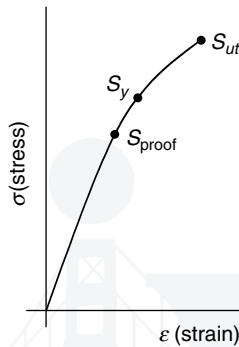

FIGURE 8.3 Stress-strain diagram for a high-strength bolt or cap screw.

Depending on whether the bolted joint will be permanent or whether it may be disassembled from time to time, the *preload* on the bolt should follow the guidelines in Eq. (8.26).

$$F_{\text{preload}} = \begin{cases} 0.90 F_{\text{proof}} & \text{permanent joint} \\ 0.75 F_{\text{proof}} & \text{disassemblable} \end{cases} \quad (8.26)$$

The preload on a bolt can be verified by three techniques:

1. Measure elongation after bolt is tight
2. Use a torque wrench with dial indicator
3. Use the turn-of-the-nut method

Measuring the elongation is the most accurate, but the most difficult to measure; using a torque wrench with a dial indicator is the most common but can be improperly calibrated; and the turn-of-the-nut method, 180° beyond *snug-tight*, is hard to define.

None of these three methods is foolproof.

8.2.4 The External Load

The external load (P) shown in Fig. 8.4 is not carried entirely by the bolt as the members have finite stiffness as calculated in Example 2.

Therefore, the total load (P) is divided between the bolt and the members, by the relationship given in Eq. (8.27) as

$$P = P_{\text{bolt}} + P_{\text{members}} \quad (8.27)$$

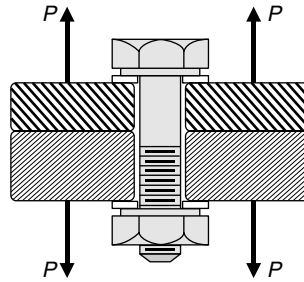

FIGURE 8.4 External load on bolted joint.

where (P_{bolt}) is the portion of the total load carried by the bolt and (P_{members}) is the portion of the total load carried by the members.

As the deflection (δ) of the bolt in tension must equal the deflection (δ) of the members in compression, Eq. (8.1) can be rearranged to give another relationship between the portion of the load carried by the bolt (P_{bolt}) and the portion carried by the members (P_{members}) as

$$\delta = \frac{P_{\text{bolt}}}{k_{\text{bolt}}} = \frac{P_{\text{members}}}{k_{\text{members}}} \quad (8.28)$$

Solve for the portion of the load carried by the bolt (P_{bolt}) in Eq. (8.28) to give

$$P_{\text{bolt}} = \frac{k_{\text{bolt}}}{k_{\text{members}}} P_{\text{members}} \quad (8.29)$$

or solve for the portion of the load carried by the members (P_{members}) in Eq. (8.28) to give

$$P_{\text{members}} = \frac{k_{\text{members}}}{k_{\text{bolt}}} P_{\text{bolt}} \quad (8.30)$$

Substitute (P_{bolt}) from Eq. (8.29) in Eq. (8.27) to give

$$\begin{aligned} P &= P_{\text{bolt}} + P_{\text{members}} = \frac{k_{\text{bolt}}}{k_{\text{members}}} P_{\text{members}} + P_{\text{members}} \\ &= \left(\frac{k_{\text{bolt}}}{k_{\text{members}}} + 1 \right) P_{\text{members}} = \left(\frac{k_{\text{bolt}} + k_{\text{members}}}{k_{\text{members}}} \right) P_{\text{members}} \end{aligned} \quad (8.31)$$

then solve for (P_{members}) to give

$$P_{\text{members}} = \left(\frac{k_{\text{members}}}{k_{\text{bolt}} + k_{\text{members}}} \right) P \quad (8.32)$$

Substitute (P_{members}) from Eq. (8.30) in Eq. (8.27) to give

$$\begin{aligned} P &= P_{\text{bolt}} + P_{\text{members}} = P_{\text{bolt}} + \frac{k_{\text{members}}}{k_{\text{bolt}}} P_{\text{bolt}} \\ &= \left(1 + \frac{k_{\text{members}}}{k_{\text{bolt}}} \right) P_{\text{bolt}} = \left(\frac{k_{\text{bolt}} + k_{\text{members}}}{k_{\text{bolt}}} \right) P_{\text{bolt}} \end{aligned} \quad (8.33)$$

then solve for (P_{bolt}) to give

$$P_{\text{bolt}} = \left(\frac{k_{\text{bolt}}}{k_{\text{bolt}} + k_{\text{members}}} \right) P \quad (8.34)$$

If a joint constant (C) is defined as

$$C = \frac{k_{\text{bolt}}}{k_{\text{bolt}} + k_{\text{members}}} \quad (8.35)$$

then ($1 - C$) is therefore

$$1 - C = 1 - \frac{k_{\text{bolt}}}{k_{\text{bolt}} + k_{\text{members}}} = \frac{k_{\text{members}}}{k_{\text{bolt}} + k_{\text{members}}} \quad (8.36)$$

Using the definition of the joint constant (C), the portion of the load carried by the bolt (P_{bolt}) given in Eq. (8.34) becomes simply

$$P_{\text{bolt}} = CP \quad (8.37)$$

and using the definition of ($1 - C$), the portion of the load carried by the members (P_{members}) given in Eq. (8.32) becomes simply

$$P_{\text{members}} = (1 - C)P \quad (8.38)$$

Therefore, the total load on the bolt (F_{bolt}) is the portion of the load (P) carried by the bolt (P_{bolt}) plus the preload (F_{preload}) and given by Eq. (8.39) as

$$F_{\text{bolt}} = P_{\text{bolt}} + F_{\text{preload}} = CP + F_{\text{preload}} \quad (8.39)$$

Similarly, the total load on the members (F_{members}) is the portion of the load (P) carried by the members (P_{members}) minus the preload (F_{preload}) and given by Eq. (8.40) as

$$F_{\text{members}} = P_{\text{members}} - F_{\text{preload}} = (1 - C)P - F_{\text{preload}} \quad (8.40)$$

where the total force on the members (F_{members}) must remain negative to make sure the joint does not separate, that is,

$$F_{\text{members}} < 0 \quad (8.41)$$

Experimental results indicate that the members can carry as much as 80 percent of the external load (P), and therefore the bolt only carries 20 percent of the load.

Consider the following example using the stiffnesses of the bolt and members found in Examples 1 and 2.

U.S. Customary	SI/Metric
<p>Example 3. Using the stiffness of the bolt (k_{bolt}) found in Example 1 and the stiffness of the members (k_{members}) found in Example 2, determine the joint constant (C), where</p> $k_{\text{bolt}} = 3.03 \times 10^6 \text{ lb/in}$ $k_{\text{members}} = 9.04 \times 10^6 \text{ lb/in}$	<p>Example 3. Using the stiffness of the bolt (k_{bolt}) found in Example 1 and the stiffness of the members (k_{members}) found in Example 2, determine the joint constant (C), where</p> $k_{\text{bolt}} = 4.66 \times 10^8 \text{ N/m}$ $k_{\text{members}} = 1.47 \times 10^9 \text{ N/m}$

U.S. Customary	SI/Metric
<p>solution <i>Step 1.</i> Using the given stiffness of the bolt and members, calculate the joint constant (C) from Eq. (8.35) as</p> $C = \frac{k_{\text{bolt}}}{k_{\text{bolt}} + k_{\text{members}}}$ $= \frac{3.03 \times 10^6 \text{ lb/in}}{(3.03 \times 10^6 + 9.04 \times 10^6) \text{ lb/in}}$ $= \frac{3.03 \times 10^6 \text{ lb/in}}{12.07 \times 10^6 \text{ lb/in}}$ $= 0.25$	<p>solution <i>Step 1.</i> Using the given stiffness of the bolt and members, calculate the joint constant (C) from Eq. (8.35) as</p> $C = \frac{k_{\text{bolt}}}{k_{\text{bolt}} + k_{\text{members}}}$ $= \frac{4.66 \times 10^8 \text{ N/m}}{(4.66 \times 10^8 + 1.47 \times 10^9) \text{ N/m}}$ $= \frac{4.66 \times 10^8 \text{ N/m}}{19.36 \times 10^8 \text{ N/m}}$ $= 0.24$

8.2.5 Static Loading

If the total load on the bolt (F_{bolt}) given by Eq. (8.39) is divided by the tensile-stress area (A_T) then the following expression is obtained.

$$\frac{F_{\text{bolt}}}{A_T} = \frac{CP}{A_T} + \frac{F_{\text{preload}}}{A_T} \quad (8.42)$$

The maximum value of the left-hand side of Eq. (8.42) is the proof strength (S_{proof}). If a load factor (n_{load}) is used, which will act like a factor-of-safety for the bolt, then Eq. (8.42) becomes

$$S_{\text{proof}} = \frac{n_{\text{load}} CP}{A_T} + \frac{F_{\text{preload}}}{A_T} \quad (8.43)$$

Solve for the load factor (n_{load}) in Eq. (8.43) to give

$$n_{\text{load}} = \frac{S_{\text{proof}} A_T - F_{\text{preload}}}{CP} \quad (8.44)$$

Using Eq. (8.25), Eq. (8.44) can be written as

$$n_{\text{load}} = \frac{F_{\text{proof}} - F_{\text{preload}}}{CP} \quad (8.45)$$

In Eq. (8.41) it was stated that the total force in the members (F_{members}) must always be negative, or compressive, to ensure that the joint will not separate, thereby placing the entire load (P) on the bolt. Therefore, a factor-of-safety against separation ($n_{\text{separation}}$) can be defined for when the total force in the members goes to zero. Setting (F_{members}) equal to zero in Eq. (8.40) gives

$$F_{\text{members}} = 0 = (1 - C)P_o - F_{\text{preload}} \quad (8.46)$$

where (P_o) is the value of the external load for separation of the joint. Solving for (P_o) in Eq. (8.46) gives

$$P_o = \frac{F_{\text{preload}}}{(1 - C)} \quad (8.47)$$

If a factor-of-safety against separation ($n_{\text{separation}}$) is defined as

$$n_{\text{separation}} = \frac{P_o}{P} \tag{8.48}$$

Substitute (P_o) from Eq. (8.47) in Eq. (8.48) to give

$$n_{\text{separation}} = \frac{F_{\text{preload}}}{P(1 - C)} \tag{8.49}$$

U.S. Customary	SI/Metric
<p>Example 4. Using the joint constant (C) found in Example 3, determine the load factor (n_{load}) and the factor-of-safety against separation ($n_{\text{separation}}$) for a bolted connection that allows periodic disassembly, where</p> <p style="margin-left: 40px;">$C = 0.25$ $P = 2,500 \text{ lb}$ $S_{\text{proof}} = 86 \text{ kpsi} = 86 \times 10^3 \text{ lb/in}^2$ $A_T = 0.142 \text{ in}^2 = 1.42 \times 10^{-1} \text{ in}^2$</p> <p>solution</p> <p><i>Step 1.</i> Use the given proof strength (S_{proof}) and tensile-stress area (A_T) in Eq. (8.25) to determine the proof load (F_{proof})</p> $F_{\text{proof}} = S_{\text{proof}} A_T$ $= (86 \times 10^3 \text{ lb/in}^2)(1.42 \times 10^{-1} \text{ in}^2)$ $= 12,200 \text{ lb}$ <p><i>Step 2.</i> Use the guidelines in Eq. (8.26) to determine the bolt preload (F_{preload}) as</p> $F_{\text{preload}} = 0.75 F_{\text{proof}}$ $= (0.75)(12,200 \text{ lb})$ $= 9,150 \text{ lb}$ <p><i>Step 3.</i> Substitute the proof load (F_{proof}) found in step 1, the bolt preload (F_{preload}) found in step 2, and the given joint constant (C) and external load (P) in Eq. (8.45) to determine the load factor (n_{load}) as</p> $n_{\text{load}} = \frac{F_{\text{proof}} - F_{\text{preload}}}{CP}$ $= \frac{(12,200 \text{ lb}) - (9,150 \text{ lb})}{(0.25)(2,500 \text{ lb})}$ $= \frac{3,050 \text{ lb}}{625 \text{ lb}} = 4.9 \cong 5$	<p>Example 4. Using the joint constant (C) found in Example 3, determine the load factor (n_{load}) and the factor-of-safety against separation ($n_{\text{separation}}$) for a bolted connection that allows periodic disassembly, where</p> <p style="margin-left: 40px;">$C = 0.24$ $P = 11,000 \text{ N}$ $S_{\text{proof}} = 600 \text{ MPa} = 600 \times 10^6 \text{ N/m}^2$ $A_T = 83.4 \text{ mm}^2 = 8.43 \times 10^{-5} \text{ m}^2$</p> <p>solution</p> <p><i>Step 1.</i> Use the given proof strength (S_{proof}) and tensile-stress area (A_T) in Eq. (8.25) to determine the proof load (F_{proof})</p> $F_{\text{proof}} = S_{\text{proof}} A_T$ $= (600 \times 10^6 \text{ N/m}^2)(8.43 \times 10^{-5} \text{ m}^2)$ $= 50,600 \text{ N}$ <p><i>Step 2.</i> Use the guidelines in Eq. (8.26) to determine the bolt preload (F_{preload}) as</p> $F_{\text{preload}} = 0.75 F_{\text{proof}}$ $= (0.75)(50,600 \text{ N})$ $= 37,950 \text{ N}$ <p><i>Step 3.</i> Substitute the proof load (F_{proof}) found in step 1, the bolt preload (F_{preload}) found in step 2, and the given joint constant (C) and external load (P) in Eq. (8.45) to determine the load factor (n_{load}) as</p> $n_{\text{load}} = \frac{F_{\text{proof}} - F_{\text{preload}}}{CP}$ $= \frac{(50,600 \text{ N}) - (37,950 \text{ N})}{(0.24)(11,000 \text{ N})}$ $= \frac{12,650 \text{ N}}{2,640 \text{ N}} = 4.8 \cong 5$

U.S. Customary	SI/Metric
<p><i>Step 4.</i> Substitute the bolt preload (F_{preload}) found in step 2, and the given joint constant (C) and external load (P) in Eq. (8.49) to determine the factor-of-safety against separation ($n_{\text{separation}}$) as</p> $n_{\text{separation}} = \frac{F_{\text{preload}}}{P(1 - C)}$ $= \frac{9,150 \text{ lb}}{(2,500 \text{ lb})(1 - 0.25)}$ $= \frac{9,150 \text{ lb}}{1,875 \text{ lb}} = 4.9 \cong 5$	<p><i>Step 4.</i> Substitute the bolt preload (F_{preload}) found in step 2, and the given joint constant (C) and external load (P) in Eq. (8.49) to determine the factor-of-safety against separation ($n_{\text{separation}}$) as</p> $n_{\text{separation}} = \frac{F_{\text{preload}}}{P(1 - C)}$ $= \frac{37,950 \text{ N}}{(11,000 \text{ N})(1 - 0.24)}$ $= \frac{37,950 \text{ N}}{8,360 \text{ N}} = 4.5$

Notice that the load factor (n_{load}) and the factor-of-safety against separation ($n_{\text{separation}}$) are very similar. This is not unexpected.

Examples 1 through 4 summarize the steps to determine if a design is safe under static loading conditions. In list form, they are:

Example 1: Determine the stiffness of the bolt (k_{bolt}), or cap screw.

Example 2: Determine the stiffness of the members (k_{members}).

Example 3: Determine the joint constant (C).

Example 4: Determine the load factor (n_{load}) and factor-of-safety against separation ($n_{\text{separation}}$).

The development of the formulas needed to determine these design parameters might have seemed at times to be excessive. However, it is important for the design engineer to feel comfortable with the formulas in a design analysis, and if only a few basic principles and simple algebra are required to show how these formulas are obtained, it is believed these developments were worthwhile.

8.2.6 Fatigue Loading

The following discussion on fatigue loading applies only to the bolt or cap screw in a connection, not the members. As the bolt or cap screw will always have a bolt preload (F_{preload}), the bolt or cap screw will experience fluctuating loading, as was discussed in Chap. 7. The maximum load on the bolt is the total bolt load (F_{bolt}) given by Eq. (8.39) and the minimum load is the bolt preload (F_{preload}) given by the guidelines of Eq. (8.26). Therefore, the mean force on the bolt (F_m) is given by Eq. (8.50) as

$$F_m = \frac{F_{\text{bolt}} + F_{\text{preload}}}{2} \quad (8.50)$$

Substitute the total bolt load (F_{bolt}) from Eq. (8.39) in Eq. (8.50) to give

$$F_m = \frac{(CP + F_{\text{preload}}) + F_{\text{preload}}}{2} = \frac{CP + 2F_{\text{preload}}}{2} = \frac{CP}{2} + F_{\text{preload}} \quad (8.51)$$

Similarly, the alternating force on the bolt (F_a) is given by Eq. (8.52) as

$$F_a = \frac{F_{\text{bolt}} - F_{\text{preload}}}{2} \quad (8.52)$$

Substitute the total bolt load (F_{bolt}) from Eq. (8.39) in Eq. (8.52) to give

$$F_a = \frac{(CP + F_{\text{preload}}) - F_{\text{preload}}}{2} = \frac{CP}{2} \quad (8.53)$$

Dividing the mean force on the bolt (F_m) given in Eq. (8.51) by the tensile-stress area (A_T) gives the mean stress on the bolt (σ_m) as

$$\sigma_m = \frac{F_m}{A_T} = \frac{CP}{2 A_T} + \frac{F_{\text{preload}}}{A_T} \quad (8.54)$$

Similarly, dividing the alternating force on the bolt (F_a) given in Eq. (8.53) by the tensile-stress area (A_T) gives the alternating stress on the bolt (σ_a) as

$$\sigma_a = \frac{F_a}{A_T} = \frac{CP}{2 A_T} \quad (8.55)$$

Comparing Eqs. (8.54) and (8.55), the mean stress on the bolt (σ_m) can be expressed as the sum of two terms

$$\sigma_m = \sigma_a + \frac{F_{\text{preload}}}{A_T} \quad (8.56)$$

where the first term (σ_a) varies with the external load (P) and the second term is constant.

If the Goodman theory is used to determine if the design is safe, then a fatigue factor-of-safety (n_{fatigue}) can be defined as

$$n_{\text{fatigue}} = \frac{S_a}{\sigma_a} \quad (8.57)$$

where (S_a) is the alternating strength of the bolt.

An expression for the mean strength of the bolt (S_m) can be found from Eq. (8.56) as

$$S_m = S_a + \frac{F_{\text{preload}}}{A_T} \quad (8.58)$$

As discussed in Chap. 7 on fluctuating loading, a graphical approach to using the Goodman theory is useful. A Goodman diagram, similar to Fig. 7.12, is shown in Fig. 8.5.

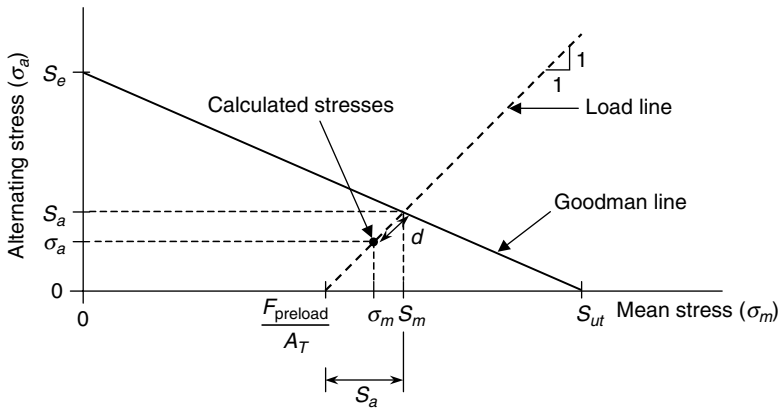

FIGURE 8.5 Graphical approach using the Goodman theory.

There are several things to notice in Fig. 8.5. First, the load line is at a 45° angle; however, it starts at the constant value of the bolt preload divided by the tensile-stress area (F_{preload}/A_T). Second, the distance (d) represents the fatigue factor-of-safety (n_{fatigue}), where the vertical distance ($S_a - \sigma_a$) is equal to the horizontal distance ($S_m - \sigma_m$). Third, the endurance limit (S_e) and ultimate tensile strength (S_{ut}) are found as usual.

Again from Chap. 7, the Goodman theory was presented mathematically in Eq. (7.22), and repeated here as

$$\frac{S_a}{S_e} + \frac{S_m}{S_{ut}} = 1 \quad (7.22)$$

As an expression is needed for the alternating strength of the bolt (S_a) to use in Eq. (8.57) to determine the fatigue factor-of-safety (n_{fatigue}), substitute the mean strength of the bolt (S_m) from Eq. (8.58) into the Goodman theory formula in Eq. (7.22) to give

$$\frac{S_a}{S_e} + \frac{S_a + \frac{F_{\text{preload}}}{A_T}}{S_{ut}} = 1 \quad (8.59)$$

Leaving out the numerous algebra steps, Eq. (8.59) can be rearranged to give the alternating strength of the bolt (S_a) as

$$S_a = \frac{S_{ut} - \frac{F_{\text{preload}}}{A_T}}{1 + \frac{S_{ut}}{S_e}} \quad (8.60)$$

Remember, the stress-concentration factor (K_f) for the bolt, which is due to the short-radius fillet under the head of the bolt and the imperfections at the start of the threads from the nominal diameter of the bolt, must be incorporated in the endurance limit (S_e) through the miscellaneous effects factor (k_e) of the Marin equation. Otherwise, the load line will not be at 45° . Stress-concentration factors (K_f) can be found in references such as *Marks' Standard Handbook for Mechanical Engineers*.

Before declaring the bolted assembly design safe, it is a good practice to determine the factor-of-safety against yielding (n_{yield}), where

$$n_{\text{yield}} = \frac{S_y}{\sigma_{\text{max}}} = \frac{S_y}{\sigma_m + \sigma_a} \quad (8.61)$$

Examples 1 through 4 considered a bolt and nut assembly, but without washers. Example 5 will consider a cap screw assembly with a single washer. The geometry and notation for a cap screw assembly is shown in Fig. 8.6.

The length of the grip (L_{grip}) is the sum of three terms as given in Eq.

$$L_{\text{grip}} = t_{\text{washer}} + t_1 + h \quad (8.62)$$

where (h) is the effective depth of the threads of the cap screw into the thickness (t_2) of the threaded member and determined by the guidelines given in Eq. (8.63) as

$$h = \begin{cases} \frac{t_2}{2} & t_2 < d \\ \frac{d}{2} & t_2 \geq d \end{cases} \quad (8.63)$$

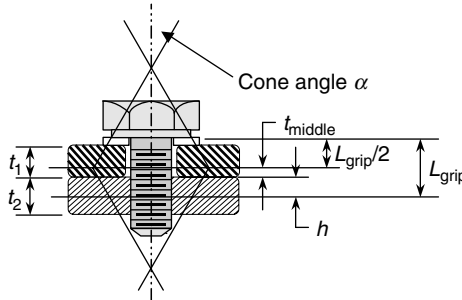

FIGURE 8.6 Cap screw connection.

As was the case with the bolt and nut assembly, the hollow frustum from under the washer face diameter of the cap screw, and the hollow frustum from the depth (h) at the same washer face diameter, meet at the midpoint of the grip ($L_{grip}/2$) as shown in Fig. 8.6. And certainly if the thicknesses of the two members (t_1) and (t_2) are not equal but even if they are equal because of the depth (h), there is a third thickness in the middle, denoted by (t_{middle}), and given by Eq. (8.64) as

$$t_{middle} = \left(\frac{L_{grip}}{2} \right) - h \tag{8.64}$$

Therefore, there are four hollow frusta that act as linear springs; one in the washer, two in the member with greater thickness, and one in the other member. To find the individual stiffness, use Eq. (8.20) for the middle thickness (t_{middle}) and Eq. (8.22) for the other three thicknesses. For the middle thickness (t_{middle}), use a corresponding special diameter (D^*) given in Eq. (8.65) as

$$D^* = D + 2h \tan \alpha \tag{8.65}$$

If the cone angle (α) is equal to 30° , and the standard washer face diameter (D) for both the bolt and the nut is equal to one and a half times the nominal diameter of the bolt, that is ($D = 1.5d$), then the special diameter (D^*) given in Eq. (8.66) becomes

$$D^* = 1.5d + 2h \tan 30^\circ \tag{8.66}$$

Once calculated, the stiffness of each frustum is then used in Eq. (8.18) to determine the overall stiffness of the members ($k_{members}$).

The effective threaded length of a cap screw (L_T) is equal to the thickness of the washer (t_{washer}) plus the thickness of the top member (t_1) plus the effective depth (h), which is the grip length (L_{grip}) and given as

$$L_T = t_{washer} + t_1 + h = L_{grip} \tag{8.67}$$

and used in Eq. (8.5) along with the tensile-stress area (A_T) and the modulus of elasticity of the cap screw (E) to determine the stiffness of the cap screw (k_T).

Consider now an example where a cap screw is used in a bolted assembly (see Fig. 8.6) under dynamic conditions. This will be a combination of steps in Examples 1 through 4, plus fatigue loading calculations; therefore this will be a long presentation.

U.S. Customary	SI/Metric
<p>Example 5. Determine the load factor (n_{load}), factor-of-safety against separation ($n_{separation}$), fatigue factor-of-safety ($n_{fatigue}$), and the factor-of-safety against yielding (n_{yield}) for a permanent high-strength cap screw and washer assembly like that shown in Fig. 8.6, where</p> $d_{capscrew} = 0.625 \text{ in (nominal)}$ $A_T = 0.226 \text{ in}^2 = 2.26 \times 10^{-1} \text{ in}^2$ $S_{proof} = 85 \text{ kpsi} = 85 \times 10^3 \text{ lb/in}^2$ $S_e = 18.6 \text{ kpsi} = 18.6 \times 10^3 \text{ lb/in}^2$ $S_{ut} = 120 \text{ kpsi} = 120 \times 10^3 \text{ lb/in}^2$ $S_y = 92 \text{ kpsi} = 92 \times 10^3 \text{ lb/in}^2$ $D = 1.5 d_{bolt} \text{ (washer face)}$ $\alpha = 30^\circ \text{ (cone angle)}$ $t_{washer} = 0.125 \text{ in (steel)}$ $t_1 = 0.625 \text{ in (steel)}$ $t_2 = 0.75 \text{ in (cast iron)}$ $E_{steel} = 30 \times 10^6 \text{ lb/in}^2$ $E_{cast iron} = 16 \times 10^6 \text{ lb/in}^2$ $P = 4,000 \text{ lb}$ <p>solution</p> <p><i>Step 1.</i> As the thickness (t_2) is greater than the nominal diameter (d), the guidelines in Eq. (8.63) give the effective depth (h) as</p> $h = \frac{d}{2} = \frac{0.625 \text{ in}}{2} = 0.3125 \text{ in}$ <p><i>Step 2.</i> Substitute the effective depth (h) found in step 1, the given thicknesses (t_{washer}) and (t_1) in Eq. (8.62) to determine the length of the grip (L_{grip}) as</p> $L_{grip} = t_{washer} + t_1 + h$ $= (0.125 \text{ in}) + (0.625 \text{ in})$ $+ (0.3125 \text{ in})$ $= 1.0625 \text{ in}$ <p><i>Step 3.</i> Using Eq. (8.67), the effective threaded length of the cap screw (L_T) is equal to the grip length (L_{grip}), therefore</p> $L_T = L_{grip} = 1.0625 \text{ in}$ <p><i>Step 4.</i> Using the threaded length (L_T) found in step 3, the given tensile-stress area (A_T), and the modulus of elasticity (E_{steel}), calculate the cap screw stiffness (k_T) using Eq. (8.5) as</p>	<p>Example 5. Determine the load factor (n_{load}), factor-of-safety against separation ($n_{separation}$), fatigue factor-of-safety ($n_{fatigue}$), and the factor-of-safety against yielding (n_{yield}) for a permanent high-strength cap screw and washer assembly like that shown in Fig. 8.6, where</p> $d_{bolt} = 16 \text{ mm} = 0.016 \text{ m (nominal)}$ $A_T = 157 \text{ mm}^2 = 1.57 \times 10^{-4} \text{ m}^2$ $S_{proof} = 600 \text{ MPa} = 600 \times 10^6 \text{ N/m}^2$ $S_e = 129 \text{ MPa} = 129 \times 10^6 \text{ N/m}^2$ $S_{ut} = 830 \text{ MPa} = 830 \times 10^6 \text{ N/m}^2$ $S_y = 660 \text{ MPa} = 660 \times 10^6 \text{ N/m}^2$ $D = 1.5 d_{bolt} \text{ (washer face)}$ $\alpha = 30^\circ \text{ (cone angle)}$ $t_{washer} = 3 \text{ mm} = 0.003 \text{ m (steel)}$ $t_1 = 16 \text{ mm} = 0.016 \text{ m (steel)}$ $t_2 = 20 \text{ mm} = 0.02 \text{ m (cast iron)}$ $E_{steel} = 207 \text{ GPa} = 207 \times 10^9 \text{ N/m}^2$ $E_{cast iron} = 110 \text{ GPa} = 110 \times 10^9 \text{ N/m}^2$ $P = 18,000 \text{ N}$ <p>solution</p> <p><i>Step 1.</i> As the thickness (t_2) is greater than the nominal diameter (d), the guidelines in Eq. (8.63) give the effective depth (h) as</p> $h = \frac{d}{2} = \frac{0.016 \text{ m}}{2} = 0.008 \text{ m}$ <p><i>Step 2.</i> Substitute the effective depth (h) found in step 1, the given thicknesses (t_{washer}) and (t_1) in Eq. (8.62) to determine the length of the grip (L_{grip}) as</p> $L_{grip} = t_{washer} + t_1 + h$ $= (0.003 \text{ m}) + (0.016 \text{ m})$ $+ (0.008 \text{ m})$ $= 0.027 \text{ m}$ <p><i>Step 3.</i> Using Eq. (8.67), the effective threaded length of the cap screw (L_T) is equal to the grip length (L_{grip}), therefore</p> $L_T = L_{grip} = 0.019 \text{ m}$ <p><i>Step 4.</i> Using the threaded length (L_T) found in step 1, the given tensile-stress area (A_T), and the modulus of elasticity (E_{steel}), calculate the cap screw stiffness (k_T) using Eq. (8.5) as</p>

U.S. Customary	SI/Metric
$k_T = \frac{A_T E_{\text{steel}}}{L_T}$ $= \frac{(2.26 \times 10^{-1} \text{ in}^2)(30 \times 10^6 \text{ lb/in}^2)}{(1.0625 \text{ in})}$ $= 6.38 \times 10^6 \text{ lb/in}$	$k_T = \frac{A_T E_{\text{steel}}}{L_T}$ $= \frac{(1.57 \times 10^{-4} \text{ m}^2)(207 \times 10^9 \text{ N/m}^2)}{(0.027 \text{ m})}$ $= 1.20 \times 10^9 \text{ N/m}$
<p>Step 5. As the thicknesses (t_1) and (t_2) are not equal, a third thickness (t_{middle}) is found from Eq. (8.64) as</p> $t_{\text{middle}} = \left(\frac{L_{\text{grip}}}{2} \right) - h$ $= \left(\frac{1.0625 \text{ in}}{2} \right) - (0.3125 \text{ in})$ $= 0.219 \text{ in}$	<p>Step 5. As the thicknesses (t_1) and (t_2) are not equal, a third thickness (t_{middle}) is found from Eq. (8.64) as</p> $t_{\text{middle}} = \left(\frac{L_{\text{grip}}}{2} \right) - h$ $= \left(\frac{0.027 \text{ m}}{2} \right) - (0.008 \text{ m})$ $= 0.0055 \text{ m}$
<p>Step 6. Using the third thickness (t_{middle}) found in step 5 in Eq. (8.66), calculate the special diameter (D^*) as</p> $D^* = 1.5d + 2h \tan 30^\circ$ $= (1.5)(0.625 \text{ in})$ $+ (2)(0.3125 \text{ in})(0.577)$ $= (0.9375 \text{ in}) + (0.625 \text{ in})(0.577)$ $= 1.30 \text{ in}$	<p>Step 6. Using the third thickness (t_{middle}) found in step 5 in Eq. (8.66), calculate the special diameter (D^*) as</p> $D^* = 1.5d + 2h \tan 30^\circ$ $= (1.5)(0.016 \text{ m})$ $+ (2)(0.008 \text{ m})(0.577)$ $= (0.024 \text{ m}) + (0.016 \text{ m})(0.577)$ $= 0.033 \text{ m}$
<p>Step 7. Substitute the special diameter (D^*) found in step 6, the third thickness (t_{middle}) found in step 5, and the given cone angle (α) and modulus of elasticity (E_{steel}), in Eq. (8.20) to find the stiffness (k_{middle}) as</p> $k_{\text{middle}} = \frac{(\pi \tan \alpha) Ed}{\ln \left[\frac{(2t \tan \alpha + D - d)(D + d)}{(2t \tan \alpha + D + d)(D - d)} \right]}$ $= \frac{(\pi \tan 30^\circ) E_{\text{steel}} d_{\text{bolt}}}{\ln \left[\frac{C_1}{C_2} \right]}$	<p>Step 7. Substitute the special diameter (D^*) found in step 6, the third thickness (t_{middle}) found in step 5, and the given cone angle (α) and modulus of elasticity (E_{steel}), in Eq. (8.20) to find the stiffness (k_{middle}) as</p> $k_{\text{middle}} = \frac{(\pi \tan \alpha) Ed}{\ln \left[\frac{(2t \tan \alpha + D - d)(D + d)}{(2t \tan \alpha + D + d)(D - d)} \right]}$ $= \frac{(\pi \tan 30^\circ) E_{\text{steel}} d_{\text{bolt}}}{\ln \left[\frac{C_1}{C_2} \right]}$
<p>where</p> $C_1 = (2t \tan \alpha + D - d)(D + d)$ $= (2t_{\text{middle}} \tan 30^\circ + D^* - d_{\text{bolt}})$ $\times (D^* + d_{\text{bolt}})$ $= \left((2)(0.219 \text{ in})(0.577) \right)$ $+ (1.30 \text{ in}) - (0.625 \text{ in})$ $\times ((1.30 \text{ in}) + (0.625 \text{ in}))$ $= (0.928 \text{ in})(1.925 \text{ in})$ $= 1.79 \text{ in}^2$	<p>where</p> $C_1 = (2t \tan \alpha + D - d)(D + d)$ $= (2t_{\text{middle}} \tan 30^\circ + D^* - d_{\text{bolt}})$ $\times (D^* + d_{\text{bolt}})$ $= \left((2)(0.0055 \text{ m})(0.577) \right)$ $+ (0.033 \text{ m}) - (0.016 \text{ m})$ $\times ((0.033 \text{ m}) + (0.016 \text{ m}))$ $= (0.023 \text{ m})(0.049 \text{ m})$ $= 0.00113 \text{ m}^2$

U.S. Customary	SI/Metric
and	and
$C_2 = (2t \tan \alpha + D + d)(D - d)$ $= (2t_{\text{middle}} \tan 30^\circ + D^* + d_{\text{bolt}})$ $\times (D^* - d_{\text{bolt}})$ $= \left((2)(0.219 \text{ in})(0.577) \right)$ $+ (1.30 \text{ in}) + (0.625 \text{ in})$ $\times ((1.30 \text{ in}) - (0.625 \text{ in}))$ $= (2.18 \text{ in})(0.675 \text{ in})$ $= 1.47 \text{ in}^2$	$C_2 = (2t \tan \alpha + D + d)(D - d)$ $= (2t_{\text{middle}} \tan 30^\circ + D^* + d_{\text{bolt}})$ $\times (D^* - d_{\text{bolt}})$ $= \left((2)(0.0055 \text{ m})(0.577) \right)$ $+ (0.033 \text{ m}) + (0.016 \text{ m})$ $\times ((0.033 \text{ m}) - (0.016 \text{ m}))$ $= (0.055 \text{ m})(0.017 \text{ m})$ $= 0.00094 \text{ m}^2$
Therefore,	Therefore,
$k_{\text{middle}} = \frac{(1.814) \left(30 \times 10^6 \frac{\text{lb}}{\text{in}^2} \right) (0.625 \text{ in})}{\ln \left[\frac{1.79 \text{ in}^2}{1.47 \text{ in}^2} \right]}$ $k_{\text{middle}} = \frac{3.40 \times 10^7 \text{ lb/in}}{0.197}$ $= 1.73 \times 10^8 \text{ lb/in}$	$k_{\text{middle}} = \frac{(1.814) \left(2.07 \times 10^{11} \frac{\text{N}}{\text{m}^2} \right) (.016 \text{ m})}{\ln \left[\frac{0.00113 \text{ m}^2}{0.00094 \text{ m}^2} \right]}$ $k_{\text{middle}} = \frac{6.00 \times 10^9 \text{ N/m}}{0.184}$ $= 3.26 \times 10^{10} \text{ N/m}$
<p><i>Step 8.</i> The remaining thickness of the steel member plus the thickness of the steel washer is half the grip length ($L_{\text{grip}}/2$). Substitute this thickness ($L_{\text{grip}}/2$), the given bolt diameter (d_{bolt}), and the modulus of elasticity (E_{steel}) in Eq. (8.22) to find the stiffness (k_1) as</p>	<p><i>Step 8.</i> The remaining thickness of the steel member plus the thickness of the steel washer is half the grip length ($L_{\text{grip}}/2$). Substitute this thickness ($L_{\text{grip}}/2$), the given bolt diameter (d_{bolt}), and the modulus of elasticity (E_{steel}) in Eq. (8.22) to find the stiffness (k_1) as</p>
$k_1 = \frac{(\pi \tan 30^\circ) E d}{\ln \left[\frac{2t \tan 30^\circ + 0.5d}{2t \tan 30^\circ + 2.5d} \right]}$ $= \frac{(\pi \tan 30^\circ) E_{\text{steel}} d_{\text{bolt}}}{\ln \left[\frac{C_1}{C_2} \right]}$	$k_1 = \frac{(\pi \tan 30^\circ) E d}{\ln \left[\frac{2t \tan 30^\circ + 0.5d}{2t \tan 30^\circ + 2.5d} \right]}$ $= \frac{(\pi \tan 30^\circ) E_{\text{steel}} d_{\text{bolt}}}{\ln \left[\frac{C_1}{C_2} \right]}$
where	where
$C_1 = 2t \tan 30^\circ + 0.5d$ $= 2 \left(\frac{L_{\text{grip}}}{2} \right) \tan 30^\circ + 0.5 d_{\text{bolt}}$ $= 2 (1.0625 \text{ in}/2) \tan 30^\circ$ $+ 0.5 (0.625 \text{ in})$ $= 0.93 \text{ in}$	$C_1 = 2t \tan 30^\circ + 0.5d$ $= 2 \left(\frac{L_{\text{grip}}}{2} \right) \tan 30^\circ + 0.5 d_{\text{bolt}}$ $= 2 (0.027 \text{ m}/2) \tan 30^\circ$ $+ 0.5 (.016 \text{ m})$ $= 0.024 \text{ m}$
and	and
$C_2 = 2t \tan 30^\circ + 2.5d$ $= 2 \left(\frac{L_{\text{grip}}}{2} \right) \tan 30^\circ + 2.5 d_{\text{bolt}}$	$C_2 = 2t \tan 30^\circ + 2.5d$ $= 2 \left(\frac{L_{\text{grip}}}{2} \right) \tan 30^\circ + 2.5 d_{\text{bolt}}$

U.S. Customary	SI/Metric
$C_2 = 2 (1.0625 \text{ in}/2) \tan 30^\circ$ $+ 2.5 (0.625 \text{ in})$ $= 2.18 \text{ in}$	$C_2 = 2 (0.027 \text{ m}/2) \tan 30^\circ$ $+ 2.5 (.016 \text{ m})$ $= 0.056 \text{ m}$
Therefore,	Therefore,
$k_1 = \frac{(1.814) \left(30 \times 10^6 \frac{\text{lb}}{\text{in}^2} \right) (0.625 \text{ in})}{\ln \left[5 \frac{0.93 \text{ in}}{2.18 \text{ in}} \right]}$ $= \frac{3.40 \times 10^7 \text{ lb/in}}{0.758}$ $= 4.49 \times 10^7 \text{ lb/in}$	$k_1 = \frac{(1.814) \left(2.07 \times 10^{11} \frac{\text{N}}{\text{m}^2} \right) (.016 \text{ m})}{\ln \left[5 \frac{0.024 \text{ m}}{0.056 \text{ m}} \right]}$ $= \frac{6.01 \times 10^9 \text{ N/m}}{0.762}$ $= 7.88 \times 10^9 \text{ N/m}$
<p><i>Step 9.</i> Substitute the effective depth (h), the bolt diameter (d_{bolt}) and the modulus of elasticity ($E_{\text{cast iron}}$) in Eq. (8.22) to find the stiffness (k_2) as</p>	<p><i>Step 9.</i> Substitute the effective depth (h), the bolt diameter (d_{bolt}), and the modulus of elasticity ($E_{\text{cast iron}}$) in Eq. (8.22) to find the stiffness (k_2) as</p>
$k_2 = \frac{(\pi \tan 30^\circ) E d}{\ln \left[5 \frac{2t \tan 30^\circ + 0.5 d}{2t \tan 30^\circ + 2.5 d} \right]}$ $= \frac{(\pi \tan 30^\circ) E_{\text{cast iron}} d_{\text{bolt}}}{\ln \left[5 \frac{C_1}{C_2} \right]}$	$k_2 = \frac{(\pi \tan 30^\circ) E d}{\ln \left[5 \frac{2t \tan 30^\circ + 0.5 d}{2t \tan 30^\circ + 2.5 d} \right]}$ $= \frac{(\pi \tan 30^\circ) E_{\text{cast iron}} d_{\text{bolt}}}{\ln \left[5 \frac{C_1}{C_2} \right]}$
where	where
$C_1 = 2t \tan 30^\circ + 0.5 d$ $= 2h \tan 30^\circ + 0.5 d_{\text{bolt}}$ $= 2 (0.3125 \text{ in}) \tan 30^\circ$ $+ 0.5 (0.625 \text{ in})$ $= 0.67 \text{ in}$	$C_1 = 2t \tan 30^\circ + 0.5 d$ $= 2h \tan 30^\circ + 0.5 d_{\text{bolt}}$ $= 2 (0.008 \text{ m}) \tan 30^\circ$ $+ 0.5 (.016 \text{ m})$ $= 0.017 \text{ m}$
and	and
$C_2 = 2t \tan 30^\circ + 2.5 d$ $= 2h \tan 30^\circ + 2.5 d_{\text{bolt}}$ $= 2 (0.3125 \text{ in}) \tan 30^\circ$ $+ 2.5 (0.625 \text{ in})$ $= 1.92 \text{ in}$	$C_2 = 2t \tan 30^\circ + 2.5 d$ $= 2h \tan 30^\circ + 2.5 d_{\text{bolt}}$ $= 2 (0.008 \text{ m}) \tan 30^\circ$ $+ 2.5 (.016 \text{ m})$ $= 0.049 \text{ m}$
Therefore,	Therefore,
$k_2 = \frac{(1.814) \left(16 \times 10^6 \frac{\text{lb}}{\text{in}^2} \right) (0.625 \text{ in})}{\ln \left[5 \frac{0.67 \text{ in}}{1.92 \text{ in}} \right]}$ $= \frac{1.81 \times 10^7 \text{ lb/in}}{0.557}$ $= 3.26 \times 10^7 \text{ lb/in}$	$k_2 = \frac{(1.814) \left(1.1 \times 10^{11} \frac{\text{N}}{\text{m}^2} \right) (.016 \text{ m})}{\ln \left[5 \frac{0.017 \text{ m}}{0.049 \text{ m}} \right]}$ $= \frac{3.19 \times 10^9 \text{ N/m}}{0.551}$ $= 5.80 \times 10^9 \text{ N/m}$

U.S. Customary	SI/Metric
<p><i>Step 10.</i> Substitute the middle stiffness (k_{middle}) found in step 7, the stiffness (k_1) found in step 8, and the stiffness (k_2) found in step 9 in Eq. (8.18) to determine the overall stiffness of the members (k_{members}) as</p>	<p><i>Step 10.</i> Substitute the middle stiffness (k_{middle}) found in step 7, the stiffness (k_1) found in step 8, and the stiffness (k_2) found in step 9 in Eq. (8.18) to determine the overall stiffness of the members (k_{members}) as</p>
$\begin{aligned} \frac{1}{k_{\text{members}}} &= \frac{1}{k_1} + \frac{1}{k_2} + \frac{1}{k_{\text{middle}}} \\ &= \frac{1}{4.49 \times 10^7 \text{ lb/in}} \\ &\quad + \frac{1}{3.26 \times 10^7 \text{ lb/in}} \\ &\quad + \frac{1}{1.73 \times 10^8 \text{ lb/in}} \\ &= \left(\begin{array}{l} 2.23 \times 10^{-8} \\ + 3.07 \times 10^{-8} \\ + 5.78 \times 10^{-9} \end{array} \right) \frac{\text{in}}{\text{lb}} \\ \frac{1}{k_{\text{members}}} &= 5.873 \times 10^{-8} \text{ in/lb} \end{aligned}$	$\begin{aligned} \frac{1}{k_{\text{members}}} &= \frac{1}{k_1} + \frac{1}{k_2} + \frac{1}{k_{\text{middle}}} \\ &= \frac{1}{7.88 \times 10^9 \text{ N/m}} \\ &\quad + \frac{1}{5.80 \times 10^9 \text{ N/m}} \\ &\quad + \frac{1}{3.26 \times 10^{10} \text{ N/m}} \\ &= \left(\begin{array}{l} 1.27 \times 10^{-10} \\ + 1.72 \times 10^{-10} \\ + 3.07 \times 10^{-11} \end{array} \right) \frac{\text{m}}{\text{N}} \\ \frac{1}{k_{\text{members}}} &= 3.300 \times 10^{-10} \text{ m/N} \end{aligned}$
<p>Therefore,</p> $\begin{aligned} k_{\text{members}} &= \frac{1}{5.873 \times 10^{-8} \text{ in/lb}} \\ &= 1.70 \times 10^7 \text{ lb/in} \\ &= 17,000 \text{ kips/in} \end{aligned}$	<p>Therefore,</p> $\begin{aligned} k_{\text{members}} &= \frac{1}{3.300 \times 10^{-10} \text{ m/N}} \\ &= 3.03 \times 10^9 \text{ N/m} \\ &= 3,030 \text{ MN/m} \end{aligned}$
<p><i>Step 11.</i> Substitute the stiffness of the cap screw (k_T) from step 2 and the stiffness of the members (k_{members}) found in step 10 in Eq. (8.35) to determine the joint constant (C) as</p>	<p><i>Step 11.</i> Substitute the stiffness of the cap screw (k_T) from step 2 and the stiffness of the members (k_{members}) found in step 10 in Eq. (8.35) to determine the joint constant (C) as</p>
$\begin{aligned} C &= \frac{k_{\text{cap screw}}}{k_{\text{cap screw}} + k_{\text{members}}} \\ &= \frac{6.38 \times 10^6 \text{ lb/in}}{(6.38 \times 10^6 + 17.00 \times 10^6) \text{ lb/in}} \\ &= \frac{6.38 \times 10^6 \text{ lb/in}}{23.38 \times 10^6 \text{ lb/in}} \\ &= 0.27 \end{aligned}$	$\begin{aligned} C &= \frac{k_{\text{cap screw}}}{k_{\text{cap screw}} + k_{\text{members}}} \\ &= \frac{1.20 \times 10^9 \text{ N/m}}{(1.20 \times 10^9 + 3.03 \times 10^9) \text{ N/m}} \\ &= \frac{1.20 \times 10^9 \text{ N/m}}{4.23 \times 10^9 \text{ N/m}} \\ &= 0.28 \end{aligned}$
<p><i>Step 12.</i> Use the given proof strength (S_{proof}) and tensile-stress area (A_T) in Eq. (8.25) to determine the proof load (F_{proof})</p>	<p><i>Step 12.</i> Use the given proof strength (S_{proof}) and tensile-stress area (A_T) in Eq. (8.25) to determine the proof load (F_{proof})</p>
$\begin{aligned} F_{\text{proof}} &= S_{\text{proof}} A_T \\ &= (85 \times 10^3 \text{ lb/in}^2)(2.26 \times 10^{-1} \text{ in}^2) \\ &= 19,200 \text{ lb} \end{aligned}$	$\begin{aligned} F_{\text{proof}} &= S_{\text{proof}} A_T \\ &= (600 \times 10^6 \text{ N/m}^2)(1.57 \times 10^{-4} \text{ m}^2) \\ &= 94,200 \text{ N} \end{aligned}$

U.S. Customary	SI/Metric
<p><i>Step 13.</i> Use the guidelines in Eq. (8.26) to determine the bolt preload (F_{preload}) as</p> $\begin{aligned} F_{\text{preload}} &= 0.90 F_{\text{proof}} \\ &= (0.90)(19,200 \text{ lb}) \\ &= 17,280 \text{ lb} \end{aligned}$ <p><i>Step 14.</i> Substitute the proof load (F_{proof}) found in step 12, the bolt preload (F_{preload}) found in step 13, the joint constant (C) found in step 11, and the given external load (P) in Eq. (8.45) to determine the load factor (n_{load}) as</p> $\begin{aligned} n_{\text{load}} &= \frac{F_{\text{proof}} - F_{\text{preload}}}{CP} \\ &= \frac{(19,200 \text{ lb}) - (17,280 \text{ lb})}{(0.27)(4,000 \text{ lb})} \\ &= \frac{1,920 \text{ lb}}{1,080 \text{ lb}} = 1.78 < 2 \end{aligned}$ <p><i>Step 15.</i> Substitute the bolt preload (F_{preload}) found in step 13, the joint constant (C) found in step 11, and the given external load (P) in Eq. (8.49) to determine the factor-of-safety against separation ($n_{\text{separation}}$) as</p> $\begin{aligned} n_{\text{separation}} &= \frac{F_{\text{preload}}}{P(1 - C)} \\ &= \frac{17,280 \text{ lb}}{(4,000 \text{ lb})(1 - 0.27)} \\ &= \frac{17,280 \text{ lb}}{2,920 \text{ lb}} = 5.9 \cong 6 \end{aligned}$ <p><i>Step 16.</i> Substitute the joint constant (C) found in step 11, and the given external load (P) and tensile-stress area (A_T) in Eq. (8.55) to determine the alternating stress on the bolt (σ_a) as</p> $\begin{aligned} \sigma_a &= \frac{CP}{2A_T} = \frac{(0.27)(4,000 \text{ lb})}{(2)(2.26 \times 10^{-1} \text{ in}^2)} \\ &= \frac{1,080 \text{ lb}}{4.52 \times 10^{-1} \text{ in}^2} \\ &= 2.39 \times 10^3 \text{ lb/in}^2 \\ &= 2.39 \text{ kpsi} \end{aligned}$	<p><i>Step 13.</i> Use the guidelines in Eq. (8.26) to determine the bolt preload (F_{preload}) as</p> $\begin{aligned} F_{\text{preload}} &= 0.90 F_{\text{proof}} \\ &= (0.90)(94,200 \text{ N}) \\ &= 84,780 \text{ N} \end{aligned}$ <p><i>Step 14.</i> Substitute the proof load (F_{proof}) found in step 12, the bolt preload (F_{preload}) found in step 13, the joint constant (C) found in step 11, and the given external load (P) in Eq. (8.45) to determine the load factor (n_{load}) as</p> $\begin{aligned} n_{\text{load}} &= \frac{F_{\text{proof}} - F_{\text{preload}}}{CP} \\ &= \frac{(94,200 \text{ N}) - (84,780 \text{ N})}{(0.28)(18,000 \text{ N})} \\ &= \frac{9,420 \text{ N}}{5,040 \text{ N}} = 1.87 < 2 \end{aligned}$ <p><i>Step 15.</i> Substitute the bolt preload (F_{preload}) found in step 13, the joint constant (C) found in step 11, and the given external load (P) in Eq. (8.49) to determine the factor-of-safety against separation ($n_{\text{separation}}$) as</p> $\begin{aligned} n_{\text{separation}} &= \frac{F_{\text{preload}}}{P(1 - C)} \\ &= \frac{84,780 \text{ N}}{(18,000 \text{ N})(1 - 0.28)} \\ &= \frac{84,780 \text{ N}}{12,960 \text{ N}} = 6.5 \end{aligned}$ <p><i>Step 16.</i> Substitute the joint constant (C) found in step 11, and the given external load (P) and tensile-stress area (A_T) in Eq. (8.55) to determine the alternating stress on the bolt (σ_a) as</p> $\begin{aligned} \sigma_a &= \frac{CP}{2A_T} = \frac{(0.28)(18,000 \text{ N})}{(2)(1.57 \times 10^{-4} \text{ m}^2)} \\ &= \frac{5,040 \text{ N}}{3.14 \times 10^{-4} \text{ m}^2} \\ &= 1.61 \times 10^7 \text{ N/m}^2 \\ &= 16.1 \text{ MPa} \end{aligned}$

U.S. Customary	SI/Metric
<p><i>Step 17.</i> Substitute the bolt preload (F_{preload}) from step 13, and the given tensile-stress area (A_T), ultimate tensile strength (S_{ut}), and endurance limit (S_e) in Eq. (8.60) to determine the alternating strength of the bolt (S_a) as</p>	<p><i>Step 17.</i> Substitute the bolt preload (F_{preload}) from step 13, and the given tensile-stress area (A_T), ultimate tensile strength (S_{ut}), and endurance limit (S_e) in Eq. (8.60) to determine the alternating strength of the bolt (S_a) as</p>
$S_a = \frac{S_{ut} - \frac{F_{\text{preload}}}{A_T}}{1 + \frac{S_{ut}}{S_e}}$ $= \frac{(120 \text{ kpsi}) - \frac{17,280 \text{ lb}}{2.26 \times 10^{-1} \text{ in}^2}}{1 + \frac{120 \text{ kpsi}}{18.6 \text{ kpsi}}}$ $= \frac{(120 \text{ kpsi}) - (76.5 \text{ kpsi})}{1 + 6.45}$ $= \frac{43.5 \text{ kpsi}}{7.45} = 5.84 \text{ kpsi}$	$S_a = \frac{S_{ut} - \frac{F_{\text{preload}}}{A_T}}{1 + \frac{S_{ut}}{S_e}}$ $= \frac{(830 \text{ MPa}) - \frac{84,780 \text{ N}}{1.57 \times 10^{-4} \text{ m}^2}}{1 + \frac{830 \text{ MPa}}{129 \text{ MPa}}}$ $= \frac{(830 \text{ MPa}) - (540 \text{ MPa})}{1 + 6.43}$ $= \frac{290 \text{ MPa}}{7.43} = 39.0 \text{ MPa}$
<p><i>Step 18.</i> Substitute the alternating stress on the bolt (σ_a) found in step 16 and the alternating strength of the bolt (S_a) found in step 17 in Eq. (8.57) to determine the fatigue factor-of-safety (n_{fatigue}) as</p>	<p><i>Step 18.</i> Substitute the alternating stress on the bolt (σ_a) found in step 16 and the alternating strength of the bolt (S_a) found in step 17 in Eq. (8.57) to determine the fatigue factor-of-safety (n_{fatigue}) as</p>
$n_{\text{fatigue}} = \frac{S_a}{\sigma_a} = \frac{5.84 \text{ kpsi}}{2.39 \text{ kpsi}} = 2.4$	$n_{\text{fatigue}} = \frac{S_a}{\sigma_a} = \frac{39.0 \text{ MPa}}{16.1 \text{ MPa}} = 2.4$
<p><i>Step 19.</i> Substitute the alternating stress on the bolt (σ_a) found in step 16, the bolt preload (F_{preload}) found in step 13, and the given tensile-stress area (A_T) in Eq. (8.56) to determine the mean stress on the bolt (σ_m) as</p>	<p><i>Step 19.</i> Substitute the alternating stress on the bolt (σ_a) found in step 16, the bolt preload (F_{preload}) found in step 13, and the given tensile-stress area (A_T) in Eq. (8.56) to determine the mean stress on the bolt (σ_m) as</p>
$\sigma_m = \sigma_a + \frac{F_{\text{preload}}}{A_T}$ $= (2.39 \text{ kpsi}) + \frac{17,280 \text{ lb}}{2.26 \times 10^{-1} \text{ in}^2}$ $= (2.39 \text{ kpsi}) + (76.46 \text{ kpsi})$ $= 78.85 \text{ kpsi}$	$\sigma_m = \sigma_a + \frac{F_{\text{preload}}}{A_T}$ $= (16.1 \text{ MPa}) + \frac{84,780 \text{ N}}{1.57 \times 10^{-4} \text{ m}^2}$ $= (16.1 \text{ MPa}) + (540.0 \text{ MPa})$ $= 556.1 \text{ MPa}$
<p><i>Step 20.</i> Substitute the alternating stress on the bolt (σ_a) found in step 16, the mean stress on the bolt (σ_m) found in step 19, and the given yield strength (S_y) in Eq. (8.61) to determine the factor-of-safety against yielding (n_{yield}) as</p>	<p><i>Step 20.</i> Substitute the alternating stress on the bolt (σ_a) found in step 16, the mean stress on the bolt (σ_m) found in step 19, and the given yield strength (S_y) in Eq. (8.61) to determine the factor-of-safety against yielding (n_{yield}) as</p>
$n_{\text{yield}} = \frac{S_y}{\sigma_m + \sigma_a}$ $= \frac{92 \text{ kpsi}}{(78.85 \text{ kpsi}) + (2.39 \text{ kpsi})}$ $= \frac{92 \text{ kpsi}}{81.24 \text{ kpsi}} = 1.13$	$n_{\text{yield}} = \frac{S_y}{\sigma_m + \sigma_a}$ $= \frac{660 \text{ MPa}}{(556.1 \text{ MPa}) + (16.1 \text{ MPa})}$ $= \frac{660 \text{ MPa}}{572.2 \text{ MPa}} = 1.15$

U.S. Customary	SI/Metric
Summarizing, $n_{\text{load}} = 1.78 < 2$ $n_{\text{separation}} = 5.9 \cong 6$ $n_{\text{fatigue}} = 2.4$ $n_{\text{yield}} = 1.13$ Only the factor-of-safety against yielding (n_{yield}) should be of concern.	Summarizing, $n_{\text{load}} = 1.87 < 2$ $n_{\text{separation}} = 6.5$ $n_{\text{fatigue}} = 2.4$ $n_{\text{yield}} = 1.15$ Only the factor-of-safety against yielding (n_{yield}) should be of concern.

8.3 WELDED CONNECTIONS

Again, as the overall theme of this book is to uncover the mystery of the formulas used in machine design for the practicing engineer, it will be assumed that the details of the nomenclature of welds and the standards of the American Welding Society (AWS) are unnecessary. Therefore the discussion will proceed directly to the first important topic for the designer, welded joints in axial and transverse loading.

8.3.1 Axial and Transverse Loading

Welds are typically of two types, butt (also called groove) and fillet. In a butt weld the two parts to be joined are literally butted together as shown in Fig. 8.7, where (P) is a tensile force and (V) is a shear force, (H) is the throat depth of the weld and (L) is the length, or width, of the weld. The butt weld fills the V-groove created by the slanted cuts made into the two parts before welding and extends in an arch on both sides of the parts called the reinforcement. Note that the throat depth (H) does not include any of the reinforcements. There are stress concentrations at the four transition lines between the reinforcement and the parts, and therefore, if the joint is subject to dynamic loading, the reinforcement should be ground smooth to avoid a fatigue failure.

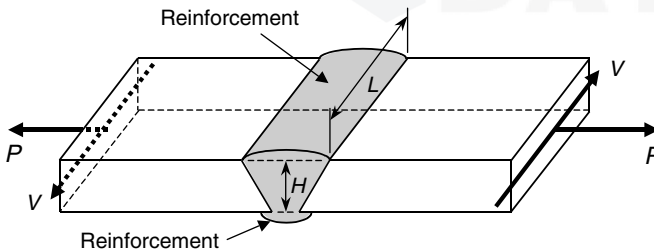

FIGURE 8.7 Typical butt weld.

The tensile force (P) and the shear force (V) may or may not act simultaneously. In any case, the normal stress (σ_{butt}) produced by the tensile force (P) in the butt weld is given by Eq. (8.68) as

$$\sigma_{\text{butt}} = \frac{P}{A_{\text{butt}}} = \frac{P}{HL} \quad (8.68)$$

and the shear stress (τ_{butt}) produced by the shear force (V) is given by Eq. (8.69) as

$$\tau_{\text{butt}} = \frac{V}{A_{\text{butt}}} = \frac{V}{HL} \quad (8.69)$$

If both are acting simultaneously, then there is combined loading on the weld and the methods of Chap. 5 are used to determine the principal stresses and the maximum and minimum shear stresses, either mathematically or graphically from Mohr's circle.

U.S. Customary	SI/Metric
<p>Example 1. A butt weld like that shown in Fig. 8.7 is subjected to both tensile force (P) and shear force (V). Determine the principal stress (σ_1) and the maximum shear stress (τ_{max}) using the mathematical formulas for combined loading, where</p> <p>$P = 1,200 \text{ lb}$ $V = 900 \text{ lb}$ $L = 3 \text{ in}$ $H = 0.25 \text{ in}$</p> <p>solution</p> <p><i>Step 1.</i> Using Eq. (8.68), calculate the normal stress in the butt weld (σ_{butt}) as</p> $\sigma_{\text{butt}} = \frac{P}{A_{\text{butt}}} = \frac{P}{HL} = \frac{1,200 \text{ lb}}{(0.25 \text{ in})(3 \text{ in})}$ $= 1,600 \text{ lb/in}^2 = 1.6 \text{ kpsi}$ $= \sigma_{xx}$ $\sigma_{yy} = 0$ <p><i>Step 2.</i> Using Eq. (8.69), calculate the shear stress in the butt weld (τ_{butt}) as</p> $\tau_{\text{butt}} = \frac{V}{A_{\text{butt}}} = \frac{V}{HL} = \frac{900 \text{ lb}}{(0.25 \text{ in})(3 \text{ in})}$ $= 1,200 \text{ lb/in}^2 = 1.2 \text{ kpsi}$ $= \tau_{xy}$ <p><i>Step 3.</i> Substitute the normal stresses ($\sigma_{\text{butt}} = \sigma_{xx}$) and ($\sigma_{yy} = 0$) from step 1 in Eq. (5.14) to determine the average stress (σ_{avg}) as</p> $\sigma_{\text{avg}} = \frac{\sigma_{xx} + \sigma_{yy}}{2} = \frac{(1.6 \text{ kpsi}) + (0)}{2}$ $= 0.8 \text{ kpsi}$ <p><i>Step 4.</i> Substitute the normal stresses ($\sigma_{\text{butt}} = \sigma_{xx}$) and ($\sigma_{yy} = 0$) from step 1 and the shear stress ($\tau_{\text{butt}} = \tau_{xy}$) from step 2 in Eq. (5.14) to</p>	<p>Example 1. A butt weld like that shown in Fig. 8.7 is subjected to both a tensile force (P) and a shear force (V). Determine the principal stress (σ_1) and the maximum shear stress (τ_{max}) using the mathematical formulas for combined loading, where</p> <p>$P = 5,400 \text{ N}$ $V = 4,050 \text{ N}$ $L = 8 \text{ cm} = 0.08 \text{ m}$ $H = 0.6 \text{ cm} = 0.006 \text{ m}$</p> <p>solution</p> <p><i>Step 1.</i> Using Eq. (8.68), calculate the normal stress in the butt weld (σ_{butt}) as</p> $\sigma_{\text{butt}} = \frac{P}{A_{\text{butt}}} = \frac{P}{HL} = \frac{5,400 \text{ N}}{(0.006 \text{ m})(0.08 \text{ m})}$ $= 11,250,000 \text{ N/m}^2 = 11.25 \text{ MPa}$ $= \sigma_{xx}$ $\sigma_{yy} = 0$ <p><i>Step 2.</i> Using Eq. (8.69), calculate the shear stress in the butt weld (τ_{butt}) as</p> $\tau_{\text{butt}} = \frac{V}{A_{\text{butt}}} = \frac{V}{HL} = \frac{4,050 \text{ N}}{(0.006 \text{ m})(0.08 \text{ m})}$ $= 8,437,500 \text{ N/m}^2 = 8.44 \text{ MPa}$ $= \tau_{xy}$ <p><i>Step 3.</i> Substitute the normal stresses ($\sigma_{\text{butt}} = \sigma_{xx}$) and ($\sigma_{yy} = 0$) from step 1 in Eq. (5.14) to determine the average stress (σ_{avg}) as</p> $\sigma_{\text{avg}} = \frac{\sigma_{xx} + \sigma_{yy}}{2} = \frac{(11.25 \text{ MPa}) + (0)}{2}$ $= 5.63 \text{ MPa}$ <p><i>Step 4.</i> Substitute the normal stresses ($\sigma_{\text{butt}} = \sigma_{xx}$) and ($\sigma_{yy} = 0$) from step 1 and the shear stress ($\tau_{\text{butt}} = \tau_{xy}$) from step 2 in Eq. (5.14) to</p>

U.S. Customary	SI/Metric
determine the maximum shear stress (τ_{\max}) as	determine the maximum shear stress (τ_{\max}) as
$\tau_{\max} = \sqrt{\left(\frac{\sigma_{xx} - \sigma_{yy}}{2}\right)^2 + \tau_{xy}^2}$ $= \sqrt{\left(\frac{(1.6) - (0)}{2}\right)^2 + (1.2)^2} \text{ kpsi}$ $= \sqrt{(0.64) + (1.44)} \text{ kpsi}$ $= \sqrt{2.08} \text{ kpsi} = 1.44 \text{ kpsi}$	$\tau_{\max} = \sqrt{\left(\frac{\sigma_{xx} - \sigma_{yy}}{2}\right)^2 + \tau_{xy}^2}$ $= \sqrt{\left(\frac{(11.25) - (0)}{2}\right)^2 + (8.44)^2} \text{ MPa}$ $= \sqrt{(31.64) + (71.23)} \text{ MPa}$ $= \sqrt{102.87} \text{ kpsi} = 10.14 \text{ MPa}$
<p><i>Step 5.</i> Substitute the average stress (σ_{avg}) from step 3 and the maximum shear stress (τ_{\max}) from step 4 in Eq. (5.15) to determine the principal stress (σ_1) as</p> $\sigma_1 = \sigma_{\text{avg}} + \tau_{\max}$ $= (0.8 \text{ kpsi}) + (1.44 \text{ kpsi})$ $= 2.24 \text{ kpsi}$	<p><i>Step 5.</i> Substitute the average stress (σ_{avg}) from step 3 and the maximum shear stress (τ_{\max}) from step 4 in Eq. (5.15) to determine the principal stress (σ_1) as</p> $\sigma_1 = \sigma_{\text{avg}} + \tau_{\max}$ $= (5.63 \text{ MPa}) + (10.14 \text{ MPa})$ $= 15.77 \text{ MPa}$

Fillet Welds. For fillet welds, the two parts to be joined together are placed such that right-angle corners are created as shown in Fig. 8.8, where (t) is the weld size and (H) is the weld throat. Not shown is the weld length (L), which is a dimension perpendicular to the page.

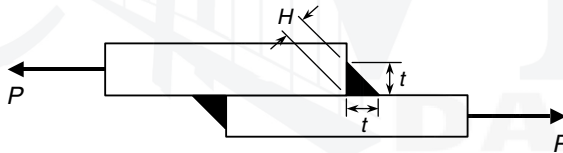

FIGURE 8.8 Fillet welds for a lap joint.

The tensile force (P) is balanced by a shear stress (τ_{fillet}) acting over the effective areas of *both* fillet welds, where *each* effective area is given by Eq. (8.70) as

$$A_{\text{fillet}} = HL = (t \cos 45^\circ) L = 0.707 tL \tag{8.70}$$

Using the effective area of one weld given in Eq. (8.70), the shear stress (τ_{fillet}) for the lap joint shown in Fig. 8.8 is given by Eq. (8.71) as

$$\tau_{\text{fillet}} = \frac{P}{2 A_{\text{fillet}}} = \frac{P}{2 (HL)} = \frac{P}{2 (0.707 t)(L)} = \frac{P}{1.414 tL} \tag{8.71}$$

If there had been only one weld, then the shear stress (τ_{fillet}) would be twice the value calculated from Eq. (8.71).

Consider the fillet welds in Fig. 8.9 where the transverse load (P) is balanced by a shear stress (τ_{fillet}) over the two weld strips of length (L) having a weld size (t).

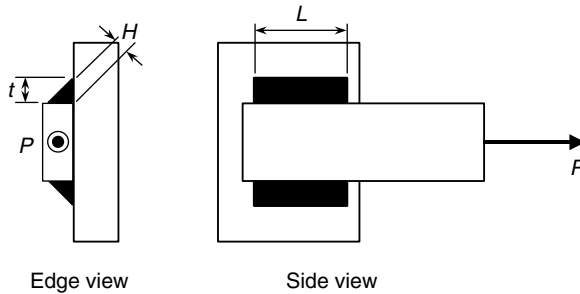

FIGURE 8.9 Fillet welds in a transverse joint.

As was the case with the lap joint in Fig. 8.8, the tensile force (P) is balanced by a shear stress (τ_{fillet}) acting over the effective areas of *both* fillet welds, where *each* effective area is again given by Eq. (8.70). Therefore, using the effective area of one weld given in Eq. (8.70), the shear stress (τ_{fillet}) for the transverse joint shown in Fig. 8.9 is also given by Eq. (8.71). Again, if there had been only one weld, then the shear stress (τ_{fillet}) would be twice the value calculated from Eq. (8.71).

Another common fillet weld configuration, the tee joint, is shown in Fig. 8.10 where the vertical load (P) acting on the joint is balanced by a shear stress (τ_{fillet}) over two weld strips of length (L), a dimension perpendicular to the page, having a weld size (t).

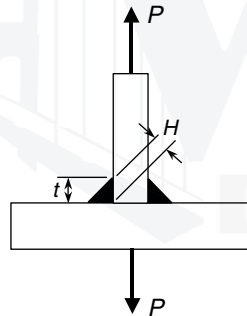

FIGURE 8.10 Fillet welds in a tee joint.

As was the case with the lap joint in Fig. 8.8 and the transverse joint in Fig. 8.9, the tensile force (P) acting on the tee joint is balanced by a shear stress (τ_{fillet}) acting over the effective areas of *both* fillet welds, where *each* effective area is again given by Eq. (8.70). Therefore, using the effective area of one weld given in Eq. (8.70), the shear stress (τ_{fillet}) for the transverse joint shown in Fig. 8.9 is also given by Eq. (8.71).

While unlikely, if there had been only one weld, then the shear stress (τ_{fillet}) would be twice the value calculated from Eq. (8.71).

Based on these three fillet weld configurations, it is hoped that a pattern has been observed in that the load (P) must be carried by a shear stress (τ_{fillet}), given by Eq. (8.71) acting over a weld area equal to the weld throat (H) times the weld length (L), where the weld throat is the weld size (t) times $\cos 45^\circ$ ($= 0.707$), and is given in Eq. (8.70).

Consider the following example.

Suppose the horizontal fillet welds for the transverse joint shown in Fig. 8.9 were placed vertically, one nearside and one farside, as shown in Fig. 8.11, where (t) is the weld size, (H) is the weld throat, and (L) is the weld length.

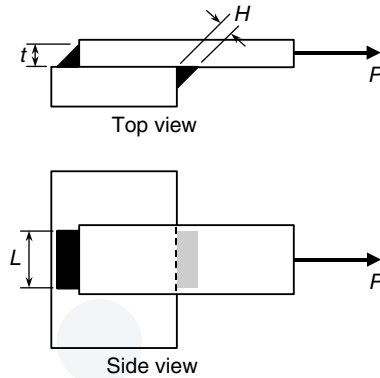

FIGURE 8.11 Vertical fillet welds in a transverse joint.

U.S. Customary	SI/Metric
<p>Example 2. For the two fillet welds shown in Fig. 8.11, determine the shear stress (τ_{fillet}), where</p> <p>$P = 2,000 \text{ lb}$ $t = 0.375 \text{ in}$ $L = 2 \text{ in}$</p> <p>solution <i>Step 1.</i> Substitute the given information in Eq. (8.71) to determine the (τ_{fillet}) as</p> $\tau_{\text{fillet}} = \frac{P}{2 A_{\text{fillet}}} = \frac{2,000 \text{ lb}}{1.414 (0.375 \text{ in})(2 \text{ in})}$ $= 1,856 \text{ lb/in}^2 = 1.86 \text{ kpsi}$ $= \tau_{xy}$	<p>Example 2. For the two fillet welds shown in Fig. 8.11, determine the shear stress (τ_{fillet}), where</p> <p>$P = 9,000 \text{ N}$ $t = 1.0 \text{ cm} = 0.01 \text{ m}$ $L = 5 \text{ cm} = 0.05 \text{ m}$</p> <p>solution <i>Step 1.</i> Substitute the given information in Eq. (8.71) to determine the (τ_{fillet}) as</p> $\tau_{\text{fillet}} = \frac{P}{2 A_{\text{fillet}}} = \frac{9,000 \text{ N}}{1.414 (0.01 \text{ m})(0.05 \text{ m})}$ $= 12,730,000 \text{ N/m}^2 = 12.73 \text{ MPa}$ $= \tau_{xy}$

8.3.2 Torsional Loading

Suppose the applied force (P) shown in Fig. 8.9 is rotated so that it is perpendicular to the arm as shown in Fig. 8.12, where (t) is the weld size, (H) is the weld throat, and (L) is the weld length.

The applied load (P) must be balanced by a shear force (V) upward and a torque (T) counterclockwise and that produce shear stresses, (τ_{shear}) and (τ_{torsion}), respectively, in the two welds. Using the dimensions shown in Fig. 8.12, the shear stress (τ_{shear}) due to the

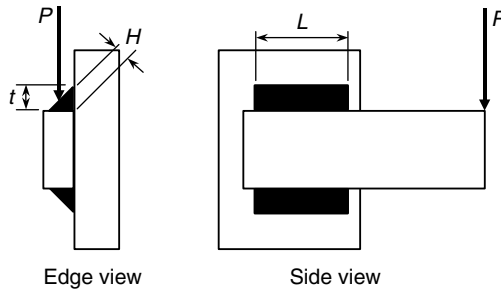

FIGURE 8.12 Fillet welds in shear and torsion.

shear force (V), which is equal to the applied load (P), is given by Eq. (8.72),

$$\tau_{\text{shear}} = \frac{V}{2 A_{\text{fillet}}} = \frac{P}{2 (HL)} = \frac{P}{2 (0.707 t)(L)} = \frac{P}{1.414 tL} \quad (8.72)$$

which is the same expression for the shear stress (τ_{fillet}) developed for the fillet weld configurations in Figs. 8.8 to 8.11 and given by Eq. (8.71).

Using the dimensions shown in Fig. 8.13, the shear stress (τ_{torsion}) due to the torque (T) is given by Eq. (8.73),

$$\tau_{\text{torsion}} = \frac{Tr_o}{J_{\text{group}}} = \frac{(PL_o) r_o}{J_{\text{group}}} \quad (8.73)$$

where (L_o) is the perpendicular distance from the centroid of the weld group, point O , to the applied load (P), (r_o) is the radial distance from the centroid of the weld group to the farthest point on any of the welds, and (J_{group}) is the polar moment of inertia of the two weld areas (each $H \times L$) about the centroid of the weld group.

Using the dimensions shown in Fig. 8.13, the radial distance (r_o) can be determined from the Pythagorean theorem as

$$r_o = \sqrt{\left(\frac{L}{2}\right)^2 + d_o^2} \quad (8.74)$$

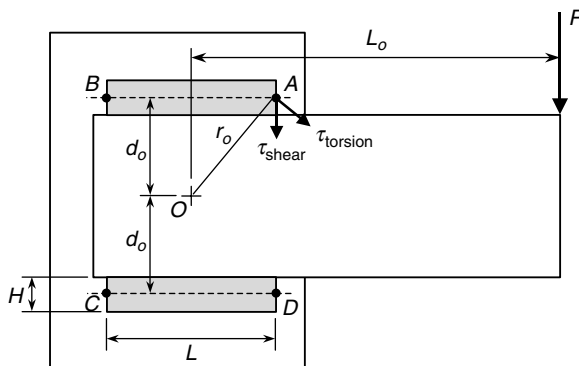

FIGURE 8.13 Fillet weld geometry for torsion.

and the polar moment of inertia (J_{group}) can be determined from the expression

$$J_{\text{group}} = 2 \left(\frac{LH^3}{12} + \frac{HL^3}{12} + LHd_o^2 \right) \quad (8.75)$$

where the factor 2 reflects the fact that there are two welds and the terms in brackets represent the application of the parallel axis theorem to the rectangular weld shapes.

Notice that the shear stress (τ_{shear}) acts downward at any point on either of the two welds; however, the shear stress (τ_{torsion}) acts perpendicular to the radial distance (r_o). There are four points, labeled (A), (B), (C), and (D) in Fig. 8.13, where the shear stress (τ_{torsion}) is maximum. The maximum shear stress (τ_{max}) is therefore the geometric sum of these two separate shear stresses and is found using the law of cosines in the scalene triangle formed by these three stresses and shown in Fig. 8.14.

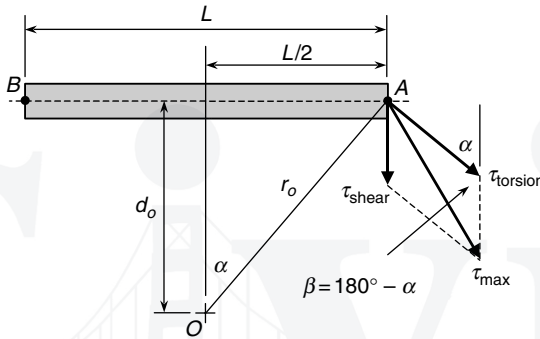

FIGURE 8.14 Maximum shear stress diagram.

The angle (α) is calculated as

$$\alpha = \tan^{-1} \frac{L/2}{d_o} \quad (8.76)$$

where (L) is the length of the weld and (d_o) is the distance from the centroid of the weld group to the centerline of the weld. The angle (β) is the supplement of the angle (α) and as shown in Fig. 8.14 is given by

$$\beta = 180^\circ - \alpha \quad (8.77)$$

Therefore, using the law of cosines on the resulting scalene triangle, the maximum shear stress (τ_{max}) is determined from Eq. (8.78) as

$$\tau_{\text{max}}^2 = \tau_{\text{shear}}^2 + \tau_{\text{torsion}}^2 - 2(\tau_{\text{shear}})(\tau_{\text{torsion}})\cos\beta \quad (8.78)$$

U.S. Customary	SI/Metric
<p>Example 3. For the fillet weld and loading configuration shown in Figs. 8.12 and 8.13, determine the maximum shear stress (τ_{max}), where</p> <p>$P = 3,000 \text{ lb}$ $H = 0.619 \text{ in } (0.875 \text{ in} \times \cos 45^\circ)$ $L = 4 \text{ in}$ $d_o = 1.5 \text{ in}$ $L_o = 1 \text{ ft} = 12 \text{ in}$</p>	<p>Example 3. For the fillet weld and loading configuration shown in Figs. 8.12 and 8.13, determine the maximum shear stress (τ_{max}), where</p> <p>$P = 13,500 \text{ N}$ $H = 1.4 \text{ cm} = 0.014 \text{ m } (2 \text{ cm} \times \cos 45^\circ)$ $L = 10 \text{ cm} = 0.1 \text{ m}$ $d_o = 4 \text{ cm} = 0.04 \text{ m}$ $L_o = 30 \text{ cm} = 0.3 \text{ m}$</p>

U.S. Customary	SI/Metric
<p>solution</p> <p><i>Step 1.</i> Substitute the given information in Eq. (8.72) to determine (τ_{shear}) as</p> $\begin{aligned}\tau_{\text{shear}} &= \frac{P}{2(HL)} \\ &= \frac{3,000 \text{ lb}}{2(0.619 \text{ in})(4 \text{ in})} \\ &= 606 \text{ lb/in}^2 = 0.61 \text{ kpsi}\end{aligned}$ <p><i>Step 2.</i> Substitute the given information in Eq. (8.74) to determine the radial distance (r_o) as</p> $\begin{aligned}r_o &= \sqrt{\left(\frac{L}{2}\right)^2 + d_o^2} \\ &= \sqrt{\left(\frac{4 \text{ in}}{2}\right)^2 + (1.5 \text{ in})^2} \\ &= \sqrt{(4 + 2.25) \text{ in}^2} \\ &= \sqrt{6.25 \text{ in}^2} = 2.5 \text{ in}\end{aligned}$ <p><i>Step 3.</i> Substitute the given information in Eq. (8.75) to determine the polar moment of inertia (J_{group}) as</p> $\begin{aligned}J_{\text{group}} &= 2\left(\frac{LH^3}{12} + \frac{HL^3}{12} + LHd_o^2\right) \\ &= 2\left(\frac{(4 \text{ in})(0.619 \text{ in})^3}{12} + \frac{(0.619 \text{ in})(4 \text{ in})^3}{12} + (4 \text{ in})(0.619 \text{ in})(1.5 \text{ in})^2\right) \\ &= 2\left(\frac{(7.9 \times 10^{-2} + 3.301)}{+5.571}\right) \text{ in}^4 \\ &= 8.95 \text{ in}^4\end{aligned}$ <p><i>Step 4.</i> Substitute the radial distance (r_o) found in step 2, the polar moment of inertia (J_{group}) found in step 3, and the given information in Eq. (8.73) to determine (τ_{torsion}) as</p> $\begin{aligned}\tau_{\text{torsion}} &= \frac{PL_o r_o}{J_{\text{group}}} \\ &= \frac{(3,000 \text{ lb})(12 \text{ in})(2.5 \text{ in})}{8.95 \text{ in}^4}\end{aligned}$	<p>solution</p> <p><i>Step 1.</i> Substitute the given information in Eq. (8.72) to determine (τ_{shear}) as</p> $\begin{aligned}\tau_{\text{shear}} &= \frac{P}{2(HL)} \\ &= \frac{13,500 \text{ N}}{2(0.014 \text{ m})(0.1 \text{ m})} \\ &= 4,821,000 \text{ N/m}^2 = 4.82 \text{ MPa}\end{aligned}$ <p><i>Step 2.</i> Substitute the given information in Eq. (8.74) to determine the radial distance (r_o) as</p> $\begin{aligned}r_o &= \sqrt{\left(\frac{L}{2}\right)^2 + d_o^2} \\ &= \sqrt{\left(\frac{0.1 \text{ m}}{2}\right)^2 + (0.04 \text{ m})^2} \\ &= \sqrt{(0.0025 + 0.0016) \text{ m}^2} \\ &= \sqrt{0.0041 \text{ m}^2} = 0.064 \text{ m}\end{aligned}$ <p><i>Step 3.</i> Substitute the given information in Eq. (8.75) to determine the polar moment of inertia (J_{group}) as</p> $\begin{aligned}J_{\text{group}} &= 2\left(\frac{LH^3}{12} + \frac{HL^3}{12} + LHd_o^2\right) \\ &= 2\left(\frac{(0.1 \text{ m})(0.014 \text{ m})^3}{12} + \frac{(0.014 \text{ m})(0.1 \text{ m})^3}{12} + (0.1 \text{ m})(0.014 \text{ m})(0.04 \text{ m})^2\right) \\ &= 2\left(\frac{(2.29 \times 10^{-8} + 1.167 \times 10^{-6})}{+2.24 \times 10^{-6}}\right) \text{ m}^4 \\ &= 3.43 \times 10^{-6} \text{ m}^4\end{aligned}$ <p><i>Step 4.</i> Substitute the radial distance (r_o) found in step 2, the polar moment of inertia (J_{group}) found in step 3, and the given information in Eq. (8.73) to determine (τ_{torsion}) as</p> $\begin{aligned}\tau_{\text{torsion}} &= \frac{PL_o r_o}{J_{\text{group}}} \\ &= \frac{(13,500 \text{ N})(0.3 \text{ m})(0.064 \text{ m})}{3.43 \times 10^{-6} \text{ m}^4}\end{aligned}$

U.S. Customary	SI/Metric
$\tau_{\text{torsion}} = \frac{90,000 \text{ lb} \cdot \text{in}^2}{8.95 \text{ in}^4}$ $= 10,056 \text{ lb/in}^2$ $= 10.06 \text{ kpsi}$	$\tau_{\text{torsion}} = \frac{259.2 \text{ N} \cdot \text{m}^2}{3.43 \times 10^{-6} \text{ m}^4}$ $= 75,570,000 \text{ N/m}^2$ $= 75.57 \text{ MPa}$
<p><i>Step 5.</i> Substitute the given information in Eq. (8.76) to determine the angle (α) as</p> $\alpha = \tan^{-1} \frac{\frac{L}{2}}{d_o} = \tan^{-1} \frac{(4 \text{ in})/2}{1.5 \text{ in}}$ $= \tan^{-1}(1.333) = 53^\circ$	<p><i>Step 5.</i> Substitute the given information in Eq. (8.76) to determine the angle (α) as</p> $\alpha = \tan^{-1} \frac{\frac{L}{2}}{d_o} = \tan^{-1} \frac{(0.1 \text{ m})/2}{0.04 \text{ m}}$ $= \tan^{-1}(1.25) = 51^\circ$
<p><i>Step 6.</i> Substitute the angle (α) found in step 5 in Eq. (8.77) to determine the angle (β) as</p> $\beta = 180^\circ - \alpha = 180^\circ - 53^\circ = 127^\circ$	<p><i>Step 6.</i> Substitute the angle (α) found in step 5 in Eq. (8.77) to determine the angle (β) as</p> $\beta = 180^\circ - \alpha = 180^\circ - 51^\circ = 129^\circ$
<p><i>Step 7.</i> Substitute the shear stress (τ_{shear}) found in step 1, the shear stress (τ_{torsion}) found in step 4, and the angle (β) found in step 6 in Eq. (8.78) to determine the maximum shear stress (τ_{max}) as</p> $\tau_{\text{max}}^2 = \tau_{\text{shear}}^2 + \tau_{\text{torsion}}^2 - 2(\tau_{\text{shear}})(\tau_{\text{torsion}})\cos\beta$ $= \left(\begin{array}{l} (0.61)^2 + (10.06)^2 \\ -2(0.61)(10.06) \\ \times (\cos 127^\circ) \end{array} \right) \text{ kpsi}^2$ $= \left(\begin{array}{l} (0.37) + (101.20) \\ -(-12.27)(-0.602) \end{array} \right) \text{ kpsi}^2$ $\tau_{\text{max}}^2 = (0.37 + 101.20 + 7.39) \text{ kpsi}^2$ $= 108.96 \text{ kpsi}^2$ $\tau_{\text{max}} = 10.44 \text{ kpsi}$	<p><i>Step 7.</i> Substitute the shear stress (τ_{shear}) found in step 1, the shear stress (τ_{torsion}) found in step 4, and the angle (β) found in step 6 in Eq. (8.78) to determine the maximum shear stress (τ_{max}) as</p> $\tau_{\text{max}}^2 = \tau_{\text{shear}}^2 + \tau_{\text{torsion}}^2 - 2(\tau_{\text{shear}})(\tau_{\text{torsion}})\cos\beta$ $= \left(\begin{array}{l} (4.82)^2 + (75.57)^2 \\ -2(4.82)(75.57) \\ \times (\cos 129^\circ) \end{array} \right) \text{ MPa}^2$ $= \left(\begin{array}{l} (23) + (5,711) \\ -(-728)(-0.629) \end{array} \right) \text{ MPa}^2$ $\tau_{\text{max}}^2 = (23 + 5,711 + 458) \text{ MPa}^2$ $= 6,192 \text{ MPa}^2$ $\tau_{\text{max}} = 78.69 \text{ MPa}$

8.3.3 Bending Loading

Consider the welded joint in Fig. 8.15 where two fillet welds support the cantilevered bar at the top and bottom and carry a downward applied load (P), and where as usual, (t) is the weld size, (H) is the weld throat, and (L) is the weld length.

The applied load (P) must be balanced by a shear force (V) upward and a bending moment (M) counterclockwise. The shear force (V) produces a shear stress (τ_{shear}) and the bending moment produces a normal stress (σ_{bending}) in the two welds. Using the dimensions shown in Fig. 8.15, the shear stress (τ_{shear}) due to the shear force (V), which is equal to the applied load (P), is given by Eq. (8.79),

$$\tau_{\text{shear}} = \frac{V}{2 A_{\text{fillet}}} = \frac{P}{2(HL)} = \frac{P}{2(0.707t)(L)} = \frac{P}{1.414tL} \quad (8.79)$$

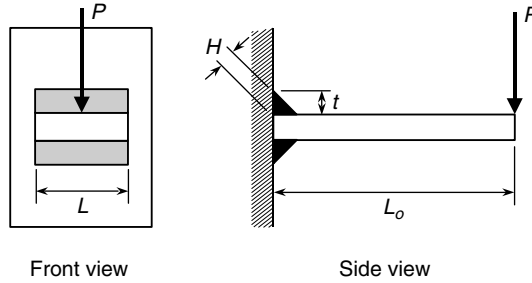

FIGURE 8.15 Fillet welds in bending.

which is the same expression for the shear stress (τ_{fillet}) given by Eq. (8.71) developed for the fillet weld configurations in Figs. 8.8, 8.9, 8.10, 8.11, and 8.13.

Using the dimensions shown in Figs. 8.15 and 8.16, the normal stress (σ_{bending}) due to the bending moment (M) is given by Eq. (8.80),

$$\tau_{\text{bending}} = \frac{M d_o}{I_{\text{group}}} = \frac{(P L_o) d_o}{I_{\text{group}}} \quad (8.80)$$

where (L_o) is the perpendicular distance from the centroid of the weld group, point O , to the applied load (P), (d_o) is the vertical distance from the centroid of the weld group to the centerline of the weld, and (I_{group}) is the moment of inertia of the weld areas about the centroid of the weld group.

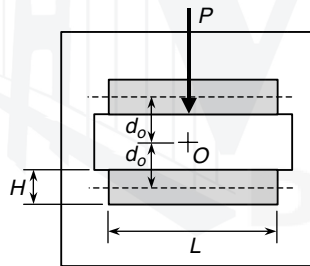

FIGURE 8.16 Fillet weld geometry for bending.

Therefore, using the dimensions shown in Fig. 8.16, the moment of inertia (I_{group}) for the fillet welds can be determined from the expression

$$I_{\text{group}} = 2 \left(\frac{LH^3}{12} + LHd_o^2 \right) \quad (8.81)$$

where the factor 2 reflects the fact that there are two welds and the terms in brackets represent the application of the parallel axis theorem to the rectangular weld shapes.

For the weld joint arrangement in Fig. 8.17, which is a variation of the weld joint arrangement shown in Fig. 8.15, the moment of inertia (I_{group}) would be given by Eq. (8.82) as

$$I_{\text{group}} = 2 \left(\frac{HL^3}{12} \right) \quad (8.82)$$

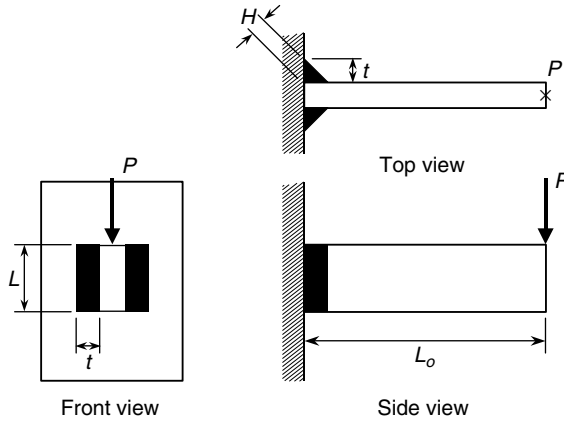

FIGURE 8.17 Vertical fillet welds in bending.

where the factor 2 represents that there are two areas over which the normal stress acts, and the single term in brackets represents the moment of inertia of the welds about their own centroidal axes.

Note that the shear stress (τ_{shear}) for the weld configuration in Fig. 8.17 would still be the same as for the weld configuration in Fig. 8.16 and given by Eq. (8.79).

Once the shear stress (τ_{shear}) and normal stress (σ_{bending}) have been determined, then the principal stress (σ_1) and maximum shear stress (τ_{max}) can be found using the methods of Chap. 5.

Consider the following example of a welded joint in bending.

U.S. Customary	SI/Metric
<p>Example 4. For the fillet weld and loading configuration shown in Figs. 8.15 and 8.16, determine the principal stress (σ_1) and maximum shear stress (τ_{max}), where</p> <p>$P = 800 \text{ lb}$ $H = 0.265 \text{ in } (0.375 \text{ in} \times \cos 45^\circ)$ $L = 2.5 \text{ in}$ $d_o = 0.75 \text{ in}$ $L_o = 1.5 \text{ ft} = 18 \text{ in}$</p> <p>solution <i>Step 1.</i> Substitute the given information in Eq. (8.79) to determine (τ_{shear}) as</p> $\begin{aligned} \tau_{\text{shear}} &= \frac{P}{2(HL)} \\ &= \frac{800 \text{ lb}}{2(0.265 \text{ in})(2.5 \text{ in})} \\ &= 604 \text{ lb/in}^2 = 0.6 \text{ kpsi} \\ &= \tau_{xy} \end{aligned}$	<p>Example 4. For the fillet weld and loading configuration shown in Figs. 8.15 and 8.16, determine the principal stress (σ_1) and maximum shear stress (τ_{max}), where</p> <p>$P = 3,600 \text{ N}$ $H = 0.7 \text{ cm} = 0.007 \text{ m } (1 \text{ cm} \times \cos 45^\circ)$ $L = 6 \text{ cm} = 0.06 \text{ m}$ $d_o = 2 \text{ cm} = 0.02 \text{ m}$ $L_o = 45 \text{ cm} = 0.45 \text{ m}$</p> <p>solution <i>Step 1.</i> Substitute the given information in Eq. (8.72) to determine (τ_{shear}) as</p> $\begin{aligned} \tau_{\text{shear}} &= \frac{P}{2(HL)} \\ &= \frac{3,600 \text{ N}}{2(0.007 \text{ m})(0.06 \text{ m})} \\ &= 4,286,000 \text{ N/m}^2 = 4.3 \text{ MPa} \\ &= \tau_{xy} \end{aligned}$

U.S. Customary	SI/Metric
<p><i>Step 2.</i> Substitute the given information in Eq. (8.81) to determine the moment of inertia (I_{group}) as</p> $I_{\text{group}} = 2 \left(\frac{LH^3}{12} + LHd_o^2 \right)$ $= 2 \left(\frac{(2.5 \text{ in})(0.265 \text{ in})^3}{12} + (2.5 \text{ in})(0.265 \text{ in})(0.75 \text{ in})^2 \right)$ $= 2((3.88 \times 10^{-3} + 3.727 \times 10^{-1}) \text{ in}^4)$ $= 7.53 \times 10^{-1} \text{ in}^4$	<p><i>Step 2.</i> Substitute the given information in Eq. (8.81) to determine the moment of inertia (I_{group}) as</p> $I_{\text{group}} = 2 \left(\frac{LH^3}{12} + LHd_o^2 \right)$ $= 2 \left(\frac{(0.06 \text{ m})(0.007 \text{ m})^3}{12} + (0.06 \text{ m})(0.007 \text{ m})(0.02 \text{ m})^2 \right)$ $= 2((1.7 \times 10^{-9} + 1.68 \times 10^{-7}) \text{ m}^4)$ $= 3.39 \times 10^{-7} \text{ m}^4$
<p><i>Step 3.</i> Substitute the moment of inertia (I_{group}) found in step 2 and the given information in Eq. (8.80) to determine (σ_{bending}) as</p> $\sigma_{\text{bending}} = \frac{PL_o d_o}{I_{\text{group}}}$ $= \frac{(800 \text{ lb})(18 \text{ in})(0.75 \text{ in})}{7.53 \times 10^{-1} \text{ in}^4}$ $= \frac{10,800 \text{ lb} \cdot \text{in}^2}{7.53 \times 10^{-1} \text{ in}^4}$ $= 14,343 \text{ lb/in}^2$ $= 14.3 \text{ kpsi}$ $= \sigma_{xx}$ $\sigma_{yy} = 0$	<p><i>Step 3.</i> Substitute the moment of inertia (I_{group}) found in step 2 and the given information in Eq. (8.80) to determine (σ_{bending}) as</p> $\sigma_{\text{bending}} = \frac{PL_o d_o}{I_{\text{group}}}$ $= \frac{(3,600 \text{ N})(0.45 \text{ m})(0.02 \text{ m})}{3.39 \times 10^{-7} \text{ m}^4}$ $= \frac{32.4 \text{ N} \cdot \text{m}^2}{3.39 \times 10^{-7} \text{ m}^4}$ $= 95,580,000 \text{ N/m}^2$ $= 95.6 \text{ MPa}$ $= \sigma_{xx}$ $\sigma_{yy} = 0$
<p><i>Step 4.</i> Substitute the normal stresses ($\sigma_{\text{bending}} = \sigma_{xx}$) and ($\sigma_{yy} = 0$) from step 3 in Eq. (5.14) to determine the average stress (σ_{avg}) as</p> $\sigma_{\text{avg}} = \frac{\sigma_{xx} + \sigma_{yy}}{2} = \frac{(14.3 \text{ kpsi}) + (0)}{2}$ $= 7.15 \text{ kpsi}$	<p><i>Step 4.</i> Substitute the normal stresses ($\sigma_{\text{bending}} = \sigma_{xx}$) and ($\sigma_{yy} = 0$) from step 3 in Eq. (5.14) to determine the average stress (σ_{avg}) as</p> $\sigma_{\text{avg}} = \frac{\sigma_{xx} + \sigma_{yy}}{2} = \frac{(95.6 \text{ MPa}) + (0)}{2}$ $= 47.8 \text{ MPa}$
<p><i>Step 5.</i> Substitute the normal stresses ($\sigma_{\text{bending}} = \sigma_{xx}$) and ($\sigma_{yy} = 0$) from step 3 and the shear stress ($\tau_{\text{shear}} = \tau_{xy}$) from step 1 in Eq. (5.14) to determine the maximum shear stress (τ_{max}) as</p> $\tau_{\text{max}} = \sqrt{\left(\frac{\sigma_{xx} - \sigma_{yy}}{2} \right)^2 + \tau_{xy}^2}$ $= \sqrt{\left(\frac{(14.3) - (0)}{2} \right)^2 + (0.6)^2} \text{ kpsi}$ $= \sqrt{(51.12) + (0.36)} \text{ kpsi}$ $= \sqrt{51.48} \text{ kpsi} = 7.18 \text{ kpsi}$	<p><i>Step 5.</i> Substitute the normal stresses ($\sigma_{\text{bending}} = \sigma_{xx}$) and ($\sigma_{yy} = 0$) from step 3 and the shear stress ($\tau_{\text{shear}} = \tau_{xy}$) from step 1 in Eq. (5.14) to determine the maximum shear stress (τ_{max}) as</p> $\tau_{\text{max}} = \sqrt{\left(\frac{\sigma_{xx} - \sigma_{yy}}{2} \right)^2 + \tau_{xy}^2}$ $= \sqrt{\left(\frac{(95.6) - (0)}{2} \right)^2 + (4.3)^2} \text{ MPa}$ $= \sqrt{(2,284.8) + (18.5)} \text{ MPa}$ $= \sqrt{2,303.3} \text{ kpsi} = 48.0 \text{ MPa}$

U.S. Customary	SI/Metric
<p><i>Step 6.</i> Substitute the average stress (σ_{avg}) from step 4 and the maximum shear stress (τ_{max}) from step 5 in Eq. (5.15) to determine the principal stress (σ_1) as</p> $\begin{aligned}\sigma_1 &= \sigma_{\text{avg}} + \tau_{\text{max}} \\ &= (7.15 \text{ kpsi}) + (7.18 \text{ kpsi}) \\ &= 14.32 \text{ kpsi}\end{aligned}$	<p><i>Step 6.</i> Substitute the average stress (σ_{avg}) from step 4 and the maximum shear stress (τ_{max}) from step 5 in Eq. (5.15) to determine the principal stress (σ_1) as</p> $\begin{aligned}\sigma_1 &= \sigma_{\text{avg}} + \tau_{\text{max}} \\ &= (47.8 \text{ MPa}) + (48.0 \text{ MPa}) \\ &= 95.8 \text{ MPa}\end{aligned}$

Note that the contribution from the shear stress (τ_{shear}) in the calculations for the principal stress (σ_1) and the maximum shear stress (τ_{max}) was almost negligible compared to the normal stress (σ_{bending}). This is typical of these kinds of weld joint configurations and loadings.

8.3.4 Fillet Welds Treated as Lines

In Examples 1 through 4, the weld throat (H) was specified as part of the given information, determined from a weld size (t). However, in practice the weld size may be the primary unknown. Therefore, it is convenient to set the weld throat (H) equal to unity (1) in the expressions for the weld area, (A_{butt}) or (A_{fillet}), the polar moment of inertia (J_{group}), and the moment of inertia (I_{group}) so that in the calculations for the stresses the units are stress times a unit width, that is, (kpsi-in) or (MPa-m). Once an appropriate weld strength (S_{weld}) is specified, dividing this strength into the calculated stress will give a value for the size of weld throat (H), from which a weld size (t) can be found.

There are sets of tabulated formulas for the weld areas and moments of inertia of various weld configurations in any number of references, such as *Marks' Standard Handbook for Mechanical Engineers*. However, to show how setting the weld throat (H) to unity (1) allows the designer to determine the required weld size (t), consider the following variation on the weld configuration in Fig. 8.12 and shown in Fig. 8.18.

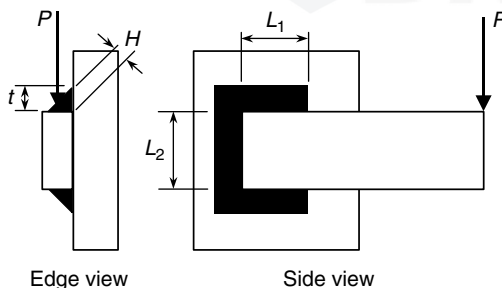

FIGURE 8.18 Fillet welds in shear and torsion.

Note that as the weld throat (H) is equal to the weld size (t) times $\cos 45^\circ$, once a value for (H) is found, divide it by $\cos 45^\circ$ ($= 0.707$) to obtain the weld size (t).

Treating the fillet welds shown in Fig. 8.18 as lines, the geometry of the joint is shown in Fig. 8.19.

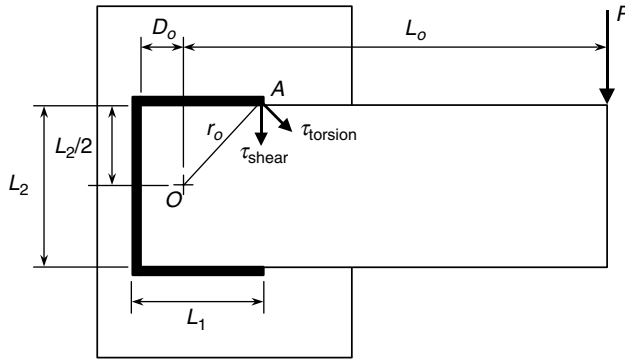

FIGURE 8.19 Geometry of fillet welds as lines in torsion.

As was presented in a previous section, the applied load (P) must be balanced by a shear force (V) upward and a torque (T) counterclockwise and that produce shear stresses, (τ_{shear}) and (τ_{torsion}), respectively, in the welds. Using the dimensions shown in Fig. 8.19, the shear stress (τ_{shear}) due to the shear force (V), which is equal to the applied load (P), is given by Eq. (8.83),

$$\tau_{\text{shear}} = \frac{V}{A_{\text{total}}} = \frac{P}{2L_1 + L_2} \quad (8.83)$$

where the weld throat (H) has been set equal to unity (1) and the number (0.707) will be divided into the value calculated for (H) to obtain the required weld size (t).

Using the dimensions shown in Fig. 8.19, the shear stress (τ_{torsion}) due to the torque (T) is still given by Eq. (8.73), and repeated here

$$\tau_{\text{torsion}} = \frac{Tr_o}{J_{\text{group}}} = \frac{(PL_o)r_o}{J_{\text{group}}} \quad (8.73)$$

where (L_o) is the perpendicular distance from the centroid of the weld group, point O , to the applied load (P), (r_o) is the radial distance from the centroid of the weld group to the farthest point on any of the welds, and (J_{group}) is the polar moment of inertia of the weld areas about the centroid of the weld group.

Using the dimensions shown in Fig. 8.19, the distance (D_o) can be determined from the expression

$$D_o = \frac{L_1^2}{2L_1 + L_2} \quad (8.84)$$

the radial distance (r_o) can be determined from the Pythagorean theorem as

$$r_o = \sqrt{\left(\frac{L_2}{2}\right)^2 + (L_1 - D_o)^2} \quad (8.85)$$

and the polar moment of inertia (J_{group}) can be determined from the expression

$$J_{\text{group}} = \frac{(2L_1 + L_2)^3}{12} - \frac{L_1^2(L_1 + L_2)^2}{2L_1 + L_2} \quad (8.86)$$

where again the weld throat (H) has been set equal to unity (1).

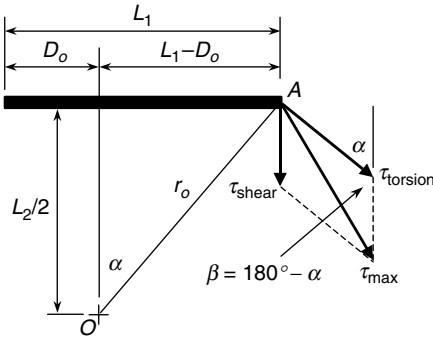

FIGURE 8.20 Maximum shear stress diagram.

The shear stress (τ_{shear}) acts downward on all the welds; however, the shear stress (τ_{torsion}) acts perpendicular to the radial distance (r_o), an angle (α) from horizontal.

Using the dimensions in Fig. 8.20, the angle (α) is calculated as

$$\alpha = \tan^{-1} \frac{L_1 - D_o}{\frac{L_2}{2}} \tag{8.87}$$

and the angle (β), which is the supplement of the angle (α), is given by

$$\beta = 180^\circ - \alpha \tag{8.88}$$

Therefore, using the law of cosines on the resulting scalene triangle formed by the three shear stresses in Fig. 8.20, the maximum shear stress (τ_{max}) is determined from Eq. (8.78). To find the required weld throat (H), divide the maximum shear stress (τ_{max}), which will have units of (stress-width), by the weld strength (S_{weld}), which will have units of (stress), that is,

$$\text{(weld throat) } H = \frac{\tau_{\text{max}}}{S_{\text{weld}}} = \frac{\text{(stress - width)}}{\text{(stress)}} = \text{(width)} \tag{8.89}$$

The required weld size (t) is then determined from the weld throat (H) as

$$\text{(weld size) } t = \frac{H}{\cos 45^\circ} \tag{8.90}$$

The weld strength in shear is specified by the particular code governing the design of the machine element. For the AWS code, the weld strength in shear is taken as 30 percent of the ultimate tensile strength (S_{ut}) of the electrode material, that is

$$S_{\text{weld}} = (0.30) S_{ut} \tag{8.91}$$

For example, E60xx electrode material has an ultimate tensile stress of 60 kpsi or 420 MPa; therefore the weld strength (S_{weld}) in shear would be

$$S_{\text{weld}} = (0.30) S_{ut} = \begin{cases} (0.30) (60 \text{ kpsi}) = 18.0 \text{ kpsi} \\ (0.30) (420 \text{ MPa}) = 126.0 \text{ MPa} \end{cases} \tag{8.92}$$

Other welding electrodes have higher ultimate tensile strengths, and therefore higher allowable weld strengths.

Consider the following example where the steps are basically the same as those for Example 3, except that the weld size (t) will be determined using Eq. (8.90).

U.S. Customary	SI/Metric
<p>Example 5. For the fillet weld and loading configuration shown in Figs. 8.18 to 8.20 determine the required weld size (t), where</p> $P = 18,000 \text{ lb}$ $L_o = 10 \text{ in}$ $L_1 = 5 \text{ in}$ $L_2 = 10 \text{ in}$ $S_{\text{weld}} = 18.0 \text{ kpsi (E60xx electrode)}$	<p>Example 5. For the fillet weld and loading configuration shown in Figs. 8.18 to 8.20 determine the required weld size (t), where</p> $P = 81,000 \text{ N}$ $L_o = 26 \text{ cm} = 0.26 \text{ m}$ $L_1 = 13 \text{ cm} = 0.13 \text{ m}$ $L_2 = 26 \text{ cm} = 0.26 \text{ m}$ $S_{\text{weld}} = 126.0 \text{ MPa (E60xx electrode)}$
<p>solution</p> <p><i>Step 1.</i> Substitute the given information in Eq. (8.83) to determine (τ_{shear}) as</p> $\begin{aligned} \tau_{\text{shear}} &= \frac{P}{2L_1 + L_2} \\ &= \frac{18,000 \text{ lb}}{2(5 \text{ in}) + (10 \text{ in})} \\ &= \frac{18,000 \text{ lb}}{20 \text{ in}} \times \frac{\text{in}}{\text{in}} \\ &= 900 \text{ (lb/in}^2\text{)} \cdot \text{in} \\ &= 0.9 \text{ kpsi} \cdot \text{in} \end{aligned}$	<p>solution</p> <p><i>Step 1.</i> Substitute the given information in Eq. (8.83) to determine (τ_{shear}) as</p> $\begin{aligned} \tau_{\text{shear}} &= \frac{P}{2L_1 + L_2} \\ &= \frac{81,000 \text{ N}}{2(0.13 \text{ m}) + (0.26 \text{ m})} \\ &= \frac{81,000 \text{ N}}{0.52 \text{ m}} \times \frac{\text{m}}{\text{m}} \\ &= 156,000 \text{ (N/m}^2\text{)} \cdot \text{m} \\ &= 0.16 \text{ MPa} \cdot \text{m} \end{aligned}$
<p><i>Step 2.</i> Substitute the given information in Eq. (8.85) to determine the distance (D_o) as</p> $\begin{aligned} D_o &= \frac{L_1^2}{2L_1 + L_2} = \frac{(5 \text{ in})^2}{2(5 \text{ in}) + (10 \text{ in})} \\ &= \frac{25 \text{ in}^2}{20 \text{ in}} = 1.25 \text{ in} \end{aligned}$	<p><i>Step 2.</i> Substitute the given information in Eq. (8.85) to determine the distance (D_o) as</p> $\begin{aligned} D_o &= \frac{L_1^2}{2L_1 + L_2} = \frac{(0.13 \text{ m})^2}{2(0.13 \text{ m}) + (0.26 \text{ m})} \\ &= \frac{0.0169 \text{ m}^2}{0.52 \text{ m}} = 0.0325 \text{ in} \end{aligned}$
<p><i>Step 3.</i> Substitute the distance (D_o) from step 2 and the given information in Eq. (8.85) to determine the radial distance (r_o) as</p> $\begin{aligned} r_o &= \sqrt{\left(\frac{L_2}{2}\right)^2 + (L_1 - D_o)^2} \\ &= \sqrt{\left(\frac{10 \text{ in}}{2}\right)^2 + (5 \text{ in} - 1.25 \text{ in})^2} \\ &= \sqrt{(25 + 14.06) \text{ in}^2} \\ &= \sqrt{39.06 \text{ in}^2} = 6.25 \text{ in} \end{aligned}$	<p><i>Step 3.</i> Substitute the distance (D_o) from step 2 and the given information in Eq. (8.85) to determine the radial distance (r_o) as</p> $\begin{aligned} r_o &= \sqrt{\left(\frac{L_2}{2}\right)^2 + (L_1 - D_o)^2} \\ &= \sqrt{\left(\frac{0.26 \text{ m}}{2}\right)^2 + (0.13 - 0.0325 \text{ m})^2} \\ &= \sqrt{(0.0169 + 0.0095) \text{ m}^2} \\ &= \sqrt{0.0264 \text{ m}^2} = 0.1625 \text{ m} \end{aligned}$

U.S. Customary	SI/Metric
<p><i>Step 4.</i> Substitute the given information in Eq. (8.86) to determine the polar moment of inertia (J_{group}) as</p> $ \begin{aligned} J_{\text{group}} &= \frac{(2L_1 + L_2)^3}{12} - \frac{L_1^2(L_1 + L_2)^2}{2L_1 + L_2} \\ &= \frac{(2(5 \text{ in}) + (10 \text{ in}))^3}{12} \\ &\quad - \frac{(5 \text{ in})^2(5 \text{ in} + 10 \text{ in})^2}{2(5 \text{ in}) + 10 \text{ in}} \\ &= \frac{(20 \text{ in})^3}{12} - \frac{(25 \text{ in}^2)(15 \text{ in})^2}{20 \text{ in}} \\ &= \frac{8,000 \text{ in}^3}{12} - \frac{5,625 \text{ in}^4}{20 \text{ in}} \\ &= (666.67 - 281.25) \text{ in}^3 \\ &= 385.4 \text{ in}^3 \end{aligned} $ <p><i>Step 5.</i> Substitute the radial distance (r_o) found in step 3, the polar moment of inertia (J_{group}) found in step 4, and the given information in Eq. (8.73) to determine (τ_{torsion}) as</p> $ \begin{aligned} \tau_{\text{torsion}} &= \frac{PL_o r_o}{J_{\text{group}}} \\ &= \frac{(18,000 \text{ lb})(10 \text{ in})(6.25 \text{ in})}{385.4 \text{ in}^3} \\ &= \frac{1,125,000 \text{ lb} \cdot \text{in}^2}{385.4 \text{ in}^3} \times \frac{\text{in}}{\text{in}} \\ &= 2,919 (\text{lb}/\text{in}^2) \cdot \text{in} \\ &= 2.9 \text{ kpsi} \cdot \text{in} \end{aligned} $ <p><i>Step 6.</i> Substitute the distance (D_o) from step 2 and the given information in Eq. (8.87) to determine the angle (α) as</p> $ \begin{aligned} \alpha &= \tan^{-1} \frac{L_1 - D_o}{\frac{L_2}{2}} \\ &= \tan^{-1} \frac{(5 \text{ in}) - (1.25 \text{ in})}{\frac{(10 \text{ in})}{2}} \\ &= \tan^{-1} \frac{3.75 \text{ in}}{5 \text{ in}} = \tan^{-1}(0.75) \\ &= 37^\circ \end{aligned} $ <p><i>Step 7.</i> Substitute the angle (α) found in step 6 in Eq. (8.88) to determine the angle (β) as</p> $\beta = 180^\circ - \alpha = 180^\circ - 37^\circ = 143^\circ$	<p><i>Step 4.</i> Substitute the given information in Eq. (8.86) to determine the polar moment of inertia (J_{group}) as</p> $ \begin{aligned} J_{\text{group}} &= \frac{(2L_1 + L_2)^3}{12} - \frac{L_1^2(L_1 + L_2)^2}{2L_1 + L_2} \\ &= \frac{(2(0.13 \text{ m}) + (0.26 \text{ m}))^3}{12} \\ &\quad - \frac{(0.13 \text{ m})^2(0.13 \text{ m} + 0.26 \text{ m})^2}{2(0.13 \text{ m}) + 0.26 \text{ m}} \\ &= \frac{(0.52 \text{ m})^3}{12} - \frac{(0.0169 \text{ m}^2)(0.39 \text{ m})^2}{0.52 \text{ m}} \\ &= \frac{0.1406 \text{ m}^3}{12} - \frac{0.00257 \text{ m}^4}{0.52 \text{ m}} \\ &= (0.01172 - 0.00494) \text{ m}^3 \\ &= 0.00678 \text{ m}^3 \end{aligned} $ <p><i>Step 5.</i> Substitute the radial distance (r_o) found in step 3, the polar moment of inertia (J_{group}) found in step 4, and the given information in Eq. (8.73) to determine (τ_{torsion}) as</p> $ \begin{aligned} \tau_{\text{torsion}} &= \frac{PL_o r_o}{J_{\text{group}}} \\ &= \frac{(81,000 \text{ N})(0.26 \text{ m})(0.1625 \text{ m})}{0.00678 \text{ m}^3} \\ &= \frac{3,422 \text{ N} \cdot \text{m}^2}{0.00678 \text{ m}^3} \times \frac{\text{m}}{\text{m}} \\ &= 504,800 (\text{N}/\text{m}^2) \cdot \text{m} \\ &= 0.50 \text{ MPa} \cdot \text{m} \end{aligned} $ <p><i>Step 6.</i> Substitute the distance (D_o) from step 2 and the given information in Eq. (8.87) to determine the angle (α) as</p> $ \begin{aligned} \alpha &= \tan^{-1} \frac{L_1 - D_o}{\frac{L_2}{2}} \\ &= \tan^{-1} \frac{(0.13 \text{ m}) - (0.0325 \text{ m})}{\frac{(0.26 \text{ m})}{2}} \\ &= \tan^{-1} \frac{0.0975 \text{ m}}{0.13 \text{ m}} = \tan^{-1}(0.75) \\ &= 37^\circ \end{aligned} $ <p><i>Step 7.</i> Substitute the angle (α) found in step 6 in Eq. (8.88) to determine the angle (β) as</p> $\beta = 180^\circ - \alpha = 180^\circ - 37^\circ = 143^\circ$

U.S. Customary	SI/Metric
<p><i>Step 8.</i> Substitute the shear stress (τ_{shear}) found in step 1, the shear stress (τ_{torsion}) found in step 5, and the angle (β) found in step 7 in Eq. (8.78) to determine the maximum shear stress (τ_{max}) as</p> $\begin{aligned}\tau_{\text{max}}^2 &= \tau_{\text{shear}}^2 + \tau_{\text{torsion}}^2 \\ &\quad - 2(\tau_{\text{shear}})(\tau_{\text{torsion}})\cos\beta \\ &= \left(\begin{array}{l} (0.9)^2 + (2.9)^2 \\ -2(0.9)(2.9) \\ \times (\cos 143^\circ) \end{array} \right) (\text{kpsi} \cdot \text{in})^2 \\ &= \left(\begin{array}{l} (0.81) + (8.41) \\ - (5.22)(-0.799) \end{array} \right) (\text{kpsi} \cdot \text{in})^2 \\ &= (0.81 + 8.41 + 4.17) (\text{kpsi} \cdot \text{in})^2 \\ &= 13.39 (\text{kpsi} \cdot \text{in})^2 \\ \tau_{\text{max}} &= 3.7 \text{ kpsi} \cdot \text{in}\end{aligned}$ <p><i>Step 9.</i> Substitute the maximum shear stress (τ_{max}) found in step 8 and the given weld strength (S_{weld}) in Eq. (8.89) to determine the weld throat (H) as</p> $\begin{aligned}(\text{weld throat}) H &= \frac{\tau_{\text{max}}}{S_{\text{weld}}} = \frac{3.7 \text{ kpsi} \cdot \text{in}}{18.0 \text{ kpsi}} \\ &= 0.206 \text{ in}\end{aligned}$ <p><i>Step 10.</i> Substitute the weld throat (H) found in step 9 in Eq. (8.90) to determine the weld size (t) as</p> $\begin{aligned}(\text{weld size}) t &= \frac{H}{\cos 45^\circ} = \frac{0.206 \text{ in}}{\cos 45^\circ} \\ &= 0.2907 \text{ in} < \frac{5}{16} \text{ in}\end{aligned}$ <p>Note that the next larger fillet weld size was chosen.</p>	<p><i>Step 8.</i> Substitute the shear stress (τ_{shear}) found in step 1, the shear stress (τ_{torsion}) found in step 5, and the angle (β) found in step 7 in Eq. (8.78) to determine the maximum shear stress (τ_{max}) as</p> $\begin{aligned}\tau_{\text{max}}^2 &= \tau_{\text{shear}}^2 + \tau_{\text{torsion}}^2 \\ &\quad - 2(\tau_{\text{shear}})(\tau_{\text{torsion}})\cos\beta \\ &= \left(\begin{array}{l} (0.16)^2 + (0.50)^2 \\ -2(0.16)(0.50) \\ \times (\cos 143^\circ) \end{array} \right) (\text{MPa} \cdot \text{m})^2 \\ &= \left(\begin{array}{l} (0.0256) + (0.25) \\ - (-0.16)(-0.799) \end{array} \right) (\text{MPa} \cdot \text{m})^2 \\ &= (0.0256 + 0.25 + 0.1278) (\text{MPa} \cdot \text{m})^2 \\ &= 0.4034 (\text{MPa} \cdot \text{m})^2 \\ \tau_{\text{max}} &= 0.64 \text{ MPa} \cdot \text{m}\end{aligned}$ <p><i>Step 9.</i> Substitute the maximum shear stress (τ_{max}) found in step 8 and the given weld strength (S_{weld}) in Eq. (8.89) to determine the weld throat (H) as</p> $\begin{aligned}(\text{weld throat}) H &= \frac{\tau_{\text{max}}}{S_{\text{weld}}} = \frac{0.64 \text{ MPa} \cdot \text{m}}{126.0 \text{ MPa}} \\ &= 0.005 \text{ m}\end{aligned}$ <p><i>Step 10.</i> Substitute the weld throat (H) found in step 9 in Eq. (8.90) to determine the weld size (t) as</p> $\begin{aligned}(\text{weld size}) t &= \frac{H}{\cos 45^\circ} = \frac{0.005 \text{ m}}{\cos 45^\circ} \\ &= 0.007 \text{ m} < 1 \text{ mm}\end{aligned}$ <p>Note that the next larger fillet weld size was chosen.</p>

8.3.5 Fatigue Loading

Designing a weld for dynamic loading is similar to that presented in Chap. 7 for fluctuating shear loading. The appropriate design theory is the Goodman theory, stated mathematically in Eq. (7.34), and repeated here as

$$\frac{\tau_a}{S_e} + \frac{\tau_m}{S_{us}} = \frac{1}{n} \quad (7.34)$$

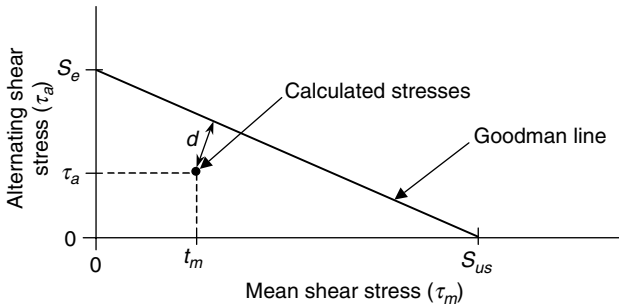

FIGURE 7.24 Goodman theory for fluctuating torsional loading.

The mean shear stress (τ_m) and the alternating shear stress (τ_a) are determined from the given loading and calculated as shown in Examples 1 through 5 in this section. Apply any stress concentration factors, which will be there if the welds are not ground smooth, to the alternating shear stress (τ_a) only, not to the mean shear stress (τ_m).

The endurance limit is determined using the Marin formula, where unless the weld is ground very smooth use a surface finish factor for *as forged*, and the size factor is determined for a rectangle, meaning an effective diameter will need to be calculated. The loading type factor is set to (0.577) for torsion, and the temperature factor is handled as usual. Apply the stress concentration factor (K_f), which should be corrected for notch sensitivity, only to the alternating shear stress (τ_a).

The ultimate shear strength (S_{us}) is determined from Eq. (7.33), repeated here as

$$S_{us} = 0.67 S_{ut} \quad (7.33)$$

where the ultimate tensile strength (S_{ut}) is for the welding electrode.

Substitute these four quantities, (τ_m), (τ_a), (S_e), and (S_{us}), in Eq. (7.34) to determine the factor-of-safety (n) for the design, or use the graphical approach to the Goodman theory for fluctuating shear loading shown in Fig. 7.24, repeated above.

CHAPTER 9

MACHINE ENERGY

9.1 INTRODUCTION

In this chapter two types of machine elements will be discussed: helical springs and flywheels. Both of these machine elements either absorb or store energy, or do both, many times in repetitive cycles. Both are very important to the machine designer. Each will be discussed with examples in both the U.S. Customary and SI/metric system of units.

Helical springs are used in a variety of machines, from high-performance engines to vegetable choppers. Helical springs can be large or small. Helical springs can be expensive one-of-a-kind, or inexpensive mass produced. All helical springs are critical to their specific application, therefore, their design must be appropriate for the expected operating conditions. The discussion on helical springs will cover: (1) terminology and geometry, (2) loads and stresses, (3) deflection, (4) spring rate, stiffness, compliance, and flexibility, (5) work and energy, (6) series and parallel arrangements, (6) extension springs, (7) compression springs, (8) stability, (9) critical frequency, and (10) fatigue loading. Along with the discussion, which includes several algebraic developments considered important for the understanding of the underlying principles, there are ten examples to provide the necessary practice in using the applicable design formulas.

Flywheels have long been used as energy storage devices for rotational motion, whether attached to the crankshaft of an automobile engine, or part of the drive system for an industrial punch press. Just the right amount of inertia must be used in the design; too little inertia and the system loses momentum each cycle, too much inertia and the system is sluggish. This design parameter, and others critical to a safe design, will be presented.

9.2 HELICAL SPRINGS

Springs absorb, store, and release energy, sometimes only infrequently, or over continuous cycles. In their design, both the level of stress and the amount of deflection is important, usually at the same time. There are many types of springs, almost too many to cover thoroughly. However, the principles presented here are applicable to all springs.

9.2.1 Loads, Stresses, and Deflection

Helical springs are what usually comes to mind when the word *springs* is used. Typically, they have circular cross sections, although other cross sections are possible, and their coils

are cylindrical, though other shapes are also possible. The geometry of a cylindrical helical spring with a circular cross section is shown in Fig. 9.1,

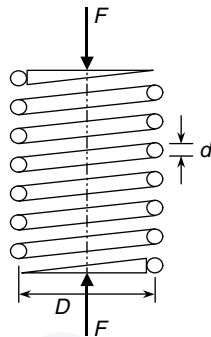

FIGURE 9.1 Geometry of a helical spring.

where (F) is the force on the spring, (D) is the mean spring diameter, and (d) is the wire diameter. While it appears that the spring is merely under a compressive axial load due to the two forces (F), the coils of the wire are actually under a combination loading of direct shear and torsion. This can be seen if a cut is made through one of the coils, resulting in the free-body-diagram (FBD) in Fig. 9.2.

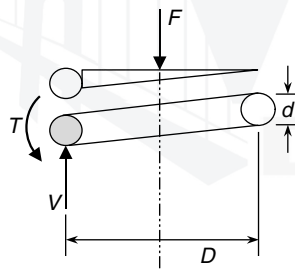

FIGURE 9.2 FBD of a cylindrical helical spring.

For equilibrium, the shear force (V) must be equal to the force (F), and the torque (T) must be equal to the force (F) times ($D/2$), the mean spring diameter (D) divided by 2. These two conditions are summarized in Eqs. (9.1) and (9.2) as

$$V = F \quad (9.1)$$

$$T = F \times \frac{D}{2} \quad (9.2)$$

The shear force (V) and the torque (T) each produce a shear stress over the circular cross section of the wire. From the discussion in Chap. 5, the combination of these two shear

stresses into a single shear stress, with no normal stresses present, is actually the maximum shear stress (τ_{\max}) and given by the two terms in Eq. (9.3) as

$$\tau_{\max} = \tau_{\text{direct shear}} + \tau_{\text{torsion}} \quad (9.3)$$

From Eq. (1.12) in Chap. 1, and using Eq. (9.1), the shear stress due to direct shear is given by Eq. (9.4) as

$$\tau_{\text{direct shear}} = \frac{V}{A} = \frac{F}{A} \quad (9.4)$$

where (A) is the cross-sectional area of the wire.

From Eq. (1.21) in Chap. 1, and using Eq. (9.2), the shear stress due to torsion is given by Eq. (9.5) as

$$\tau_{\text{torsion}} = \frac{Tr}{J} = \frac{\left(F \times \frac{D}{2}\right)r}{J} = \frac{FDr}{2J} \quad (9.5)$$

where (r) is the outside radius and (J) is the polar moment of inertia of the wire.

For a circular cross section with a diameter (d), the area (A), the outside radius (r), and the polar moment of inertia (J) are given by the following equations

$$A = \frac{\pi}{4}d^2 \quad (9.6)$$

$$r = \frac{d}{2} \quad (9.7)$$

$$J = \frac{1}{2}\pi r^4 = \frac{1}{2}\pi \left(\frac{d}{2}\right)^4 = \frac{\pi}{32}d^4 \quad (9.8)$$

Substituting these expressions for the area (A), the outside radius (r), and the polar moment of inertia (J) in Eqs. (9.4) and (9.5) gives

$$\tau_{\text{direct shear}} = \frac{F}{A} = \frac{F}{\frac{\pi}{4}d^2} = \frac{4F}{\pi d^2} \quad (9.9)$$

$$\tau_{\text{torsion}} = \frac{FDr}{2J} = \frac{FD\left(\frac{d}{2}\right)}{2\left(\frac{\pi}{32}d^4\right)} = \frac{8FD}{\pi d^3} \quad (9.10)$$

Substituting the expression for the shear stress due to direct shear from Eq. (9.9) and the expression for the shear stress due to torsion from Eq. (9.10) in Eq. (9.3) gives Eq. (9.11).

$$\tau_{\max} = \tau_{\text{direct shear}} + \tau_{\text{torsion}} = \frac{4F}{\pi d^2} + \frac{8FD}{\pi d^3} = \left(\frac{d}{2D} + 1\right) \frac{8FD}{\pi d^3} \quad (9.11)$$

If a spring index (C) is defined as

$$C = \frac{D}{d} \quad \text{where } 6 \leq C \leq 12 \quad (9.12)$$

then using this spring index (C) in the expression for the maximum shear stress (τ_{\max}) in Eq. (9.11) gives

$$\tau_{\max} = K_s \frac{8FD}{\pi d^3} \quad (9.13)$$

where (K_s) is called the shear-stress correction factor given by Eq. (9.14).

$$K_s = \frac{1}{2C} + 1 = \frac{1 + 2C}{2C} \quad (9.14)$$

When springs are subjected to fatigue loading, high localized stresses occur on the inside surface of the coils. Therefore, the factor (K_s) given in Eq. (9.14) is replaced by either of the following factors:

$$K_W = \frac{4C - 1}{4C - 4} + \frac{0.615}{C} \quad \text{Wahl factor} \quad (9.15)$$

$$K_B = \frac{4C + 2}{4C - 3} \quad \text{Bergstrasser factor} \quad (9.16)$$

However, as these two factors differ by less than 1 percent, the Bergstrasser factor in Eq. (9.16) is preferred merely on the grounds of mathematical simplicity.

To separate out the curvature effect from the effect of direct shear, a factor (K_c) is used in the standard fatigue equation, where

$$K_c = \frac{K_B}{K_s} = \frac{(2C)(4C + 2)}{(1 + 2C)(4C - 3)} \quad (9.17)$$

therefore the reduced stress-concentration factor (K_f) becomes

$$K_f = \frac{1}{K_c} \quad (9.18)$$

Consider the following example associated with the helical spring of a flyball governor used to control the speed of stationary engines. Such a spring is under repeated reversed dynamic loading, so designing against a fatigue failure is necessary.

U.S. Customary	SI/Metric
<p>Example 1. Determine the wire diameter (d) and mean diameter (D) for a helical spring using the Bergstrasser factor (K_B), where</p> $F = 130 \text{ lb}$ $C = 8$ $\tau_{\max} = 50 \text{ kpsi} = 5 \times 10^4 \text{ lb/in}^2$ <p>solution</p> <p><i>Step 1.</i> As there is dynamic loading, calculate the Bergstrasser factor (K_B) using Eq. (9.16).</p> $K_B = \frac{4C + 2}{4C - 3} = \frac{4(8) + 2}{4(8) - 3} = \frac{34}{29} = 1.172$	<p>Example 1. Determine the wire diameter (d) and mean diameter (D) for a helical spring using the Bergstrasser factor (K_B), where</p> $F = 585 \text{ N}$ $C = 8$ $\tau_{\max} = 350 \text{ MPa} = 3.5 \times 10^8 \text{ N/m}^2$ <p>solution</p> <p><i>Step 1.</i> As there is dynamic loading, calculate the Bergstrasser factor (K_B) using Eq. (9.16).</p> $K_B = \frac{4C + 2}{4C - 3} = \frac{4(8) + 2}{4(8) - 3} = \frac{34}{29} = 1.172$

U.S. Customary	SI/Metric
<p><i>Step 2.</i> Substitute the Bergsträsser factor (K_B) found in step 1 and the other given information in Eq. (9.13).</p> $\tau_{\max} = K_B \frac{8CF}{\pi d^2}$ $5 \times 10^4 \text{ lb/in}^2 = (1.172) \frac{(8)(8)(130 \text{ lb})}{\pi d^2}$ <p><i>Step 3.</i> Solve for the wire diameter (d) from step 2.</p> $d^2 = \frac{(1.172)(8)(8)(130 \text{ lb})}{\pi(50,000 \text{ lb/in}^2)}$ $= 0.0621 \text{ in}^2$ $d = 0.25 \text{ in}$ <p><i>Step 4.</i> Using the definition of the spring index (C) from Eq. (9.12) and the wire diameter (d) found in step 3, calculate the mean spring diameter (D).</p> $C = \frac{D}{d}$ $8 = \frac{D}{0.25 \text{ in}}$ $D = (8)(0.25 \text{ in})$ $= 2.0 \text{ in}$	<p><i>Step 2.</i> Substitute the Bergsträsser factor (K_B) found in step 1 and the other given information in Eq. (9.13).</p> $\tau_{\max} = K_B \frac{8CF}{\pi d^2}$ $3.5 \times 10^8 \text{ N/m}^2 = (1.172) \frac{(8)(8)(585 \text{ N})}{\pi d^2}$ <p><i>Step 3.</i> Solve for the wire diameter (d) from step 2.</p> $d^2 = \frac{(1.172)(8)(8)(585 \text{ N})}{\pi(3.5 \times 10^8 \text{ N/m}^2)}$ $= 0.00004 \text{ m}^2$ $d = 0.00632 \text{ m} = 6.32 \text{ mm}$ <p><i>Step 4.</i> Using the definition of the spring index (C) from Eq. (9.12) and the wire diameter (d) found in step 3, calculate the mean spring diameter (D).</p> $C = \frac{D}{d}$ $8 = \frac{D}{6.32 \text{ mm}}$ $D = (8)(6.32 \text{ mm})$ $= 50.6 \text{ mm} = 5.06 \text{ cm}$

Deflection. Without providing the details of its development, the deflection (y) of a cylindrical helical spring can be determined using strain energy theory to give the expression in Eq. (9.19)

$$y = \frac{8FD^3N_a}{d^4G} \quad (9.19)$$

where (N_a) is the number of active coils and (G) is the shear modulus of elasticity.

If the deflection (y) is given, then Eq. (9.19) can be rearranged to give the number of active coils (N_a) as

$$N_a = \frac{yd^4G}{8FD^3} \quad (9.20)$$

The total number of coils (N) will be the number of active coils (N_a) plus any additional coils that are needed, depending on the type of ends, particularly if either end of the spring has one of the many common hook designs. The topic of ends and hooks will be discussed shortly.

9.2.2 Spring Rate

The relationship between the force (F_s) produced by a spring, whether it is extended or compressed, and the displacement (x), meaning change in length, can be linear or nonlinear.

For a linear spring, this relationship is given in Eq. (9.21) as

$$F_s = -kx \quad (9.21)$$

where (k) is called the spring rate of the spring.

The minus sign ($-$) is needed in Eq. (9.21) because the spring force (F_s) is a restoring force, meaning it is always in the opposite direction from the displacement (x). That is, if the spring is compressed, which is a negative displacement (x), then the spring force (F_s) is positive. Conversely, if the spring is extended, which is a positive displacement (x), then the spring force (F_s) will be negative.

Based on the linear relationship given in Eq. (9.21), the units of the spring rate (k) are force per length. If the relationship were not linear, then the units of (k) would be such that when multiplied by the displacement (x), the units for (F_s) would still be force.

The relationship between the spring force (F_s) and the displacement (x), without the minus sign ($-$), given in Eq. (9.21) is shown graphically in Fig. 9.3.

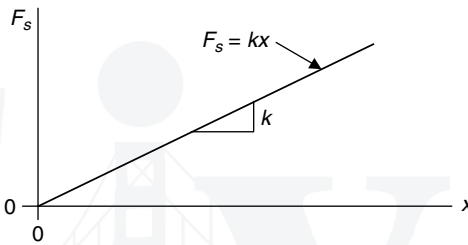

FIGURE 9.3 Spring force versus displacement.

The spring rate (k) is therefore the slope of the straight line representing the linear relationship between the spring force and the displacement. Note that the zero (0) point on the horizontal displacement (x) axis does not represent a zero length of the spring. Rather, it represents the unstretched length of the spring.

Solving for the spring rate (k) in Eq. (9.21), and dropping the minus sign ($-$), gives

$$k = \frac{F_s}{x} \quad (9.22)$$

where any combination of spring force (F_s) and the displacement (x) can be used.

The spring rate (k) given in Eq. (9.22) can be generalized for any spring type, whether helical, leaf, torsion, or any other type, as

$$\text{spring rate } (k) = \frac{\text{spring force}}{\text{displacement}} \quad (9.23)$$

For cylindrical helical springs, the spring force is the force (F) and the displacement is the deflection (y) from Eq. (9.19) so that the generalization in Eq. (9.23) gives the spring rate (k) as

$$k = \frac{\text{spring force}}{\text{displacement}} = \frac{F}{y} = \frac{d^4 G}{8D^3 N_a} \quad (9.24)$$

If the spring rate (k) is known, then Eq. (9.24) can be rearranged to give an expression for the number of active coils (N_a) as

$$N_a = \frac{d^4 G}{8D^3 k} \quad (9.25)$$

Terminology. The spring rate (k) is also called the stiffness, and the reciprocal of the stiffness is called the compliance or the flexibility (f), which has units of length per unit force. Typically, the compliance is used in place of stiffness when electrical circuit theory is used to simulate the dynamic response of mechanical systems, such as in automatic feedback controls.

Consider the following example where the mean diameter (D), the force (F), and the maximum shear stress (τ_{\max}) are given and the wire diameter (d) is to be determined.

U.S. Customary	SI/Metric
<p>Example 2. Determine the wire diameter (d) for a cylindrical helical spring under static conditions, where</p> $D = 1 \text{ in}$ $F = 50 \text{ lb}$ $\tau_{\max} = 100 \text{ kpsi} = 1 \times 10^5 \text{ lb/in}^2$ <p>solution</p> <p><i>Step 1.</i> As the loading is static, substitute the given information in Eq. (9.11) to give</p> $\tau_{\max} = \left(\frac{d}{2D} + 1 \right) \frac{8FD}{\pi d^3}$ $1 \times 10^5 \text{ lb/in}^2 = \left(\frac{d}{2(1 \text{ in})} + 1 \right) \times \frac{(8)(50 \text{ lb})(1 \text{ in})}{\pi d^3}$ <p><i>Step 2.</i> Solve for the cube of the wire diameter (d^3) in the expression in step 1.</p> $d^3 = \left(\frac{d}{2} + 1 \right) \frac{(8)(50 \text{ lb})(1 \text{ in})}{\pi (1 \times 10^5 \text{ lb/in}^2)}$ $= \left(\frac{d}{2} + 1 \right) \left(\frac{1}{785} \right) \text{ in}^3$ <p><i>Step 3.</i> Multiply the expression in step 2 throughout by (2×785) and move all terms to the left hand side to give the cubic equation (without units) as</p> $(1,570)d^3 - d - 2 = 0$ <p><i>Step 4.</i> Solve the cubic equation in step 3 by trial and error. Start with a guess of (0.25) to determine the wire diameter (d) to engineering accuracy.</p> $(1,570)d^3 - d - 2 = 0$ $(1,570)(0.25)^3 - (0.25) - 2 \stackrel{?}{=} 0$ $(24.53) - (0.25) - 2 \stackrel{?}{=} 0$ $22.28 > 0 \text{ (guess too high)}$	<p>Example 2. Determine the wire diameter (d) for a cylindrical helical spring under static conditions, where</p> $D = 2.5 \text{ cm} = 0.025 \text{ m}$ $F = 225 \text{ N}$ $\tau_{\max} = 700 \text{ MPa} = 7 \times 10^8 \text{ N/m}^2$ <p>solution</p> <p><i>Step 1.</i> As the loading is static, substitute the given information in Eq. (9.11) to give</p> $\tau_{\max} = \left(\frac{d}{2D} + 1 \right) \frac{8FD}{\pi d^3}$ $7 \times 10^8 \text{ N/m}^2 = \left(\frac{d}{2(0.025 \text{ m})} + 1 \right) \times \frac{(8)(225 \text{ N})(0.025 \text{ m})}{\pi d^3}$ <p><i>Step 2.</i> Solve for the cube of the wire diameter (d^3) in the expression in step 1.</p> $d^3 = \left(\frac{d}{0.05} + 1 \right) \frac{(8)(225 \text{ N})(0.025 \text{ m})}{\pi (7 \times 10^8 \text{ N/m}^2)}$ $= \left(\frac{d}{2} + 1 \right) \left(\frac{1}{4.9 \times 10^7} \right) \text{ m}^3$ <p><i>Step 3.</i> Multiply the expression in step 2 throughout by $(2 \times 4.9 \times 10^7)$ and move all terms to the left hand side to give the cubic equation (without units) as</p> $(9.8 \times 10^7)d^3 - d - 2 = 0$ <p><i>Step 4.</i> Solve the cubic equation in step 3 by trial and error. Start with a guess of (0.006) to determine the wire diameter (d) to engineering accuracy.</p> $(9.8 \times 10^7)d^3 - d - 2 = 0$ $(9.8 \times 10^7)(0.006)^3 - (0.006) - 2 \stackrel{?}{=} 0$ $(21.168) - (0.006) - 2 \stackrel{?}{=} 0$ $19.162 > 0 \text{ (guess too high)}$

U.S. Customary	SI/Metric
<p>Try a guess of (0.125)</p> $(1,570)d^3 - d - 2 = 0$ $(1,570)(0.125)^3 - (0.125) - 2 \stackrel{?}{=} 0$ $(3.066) - (0.125) - 2 \stackrel{?}{=} 0$ $0.941 > 0 \text{ (guess slightly too high)}$ <p>Try a guess of (0.125 - 0.005 = 0.12)</p> $(1,570)d^3 - d - 2 = 0$ $(1,570)(0.12)^3 - (0.12) - 2 \stackrel{?}{=} 0$ $(2.713) - (0.12) - 2 \stackrel{?}{=} 0$ $0.593 > 0 \text{ (guess still too high)}$ <p>Try a guess of (0.12 - 0.01 = 0.11)</p> $(1,570)d^3 - d - 2 = 0$ $(1,570)(0.11)^3 - (0.11) - 2 \stackrel{?}{=} 0$ $(2.09) - (0.11) - 2 \stackrel{?}{=} 0$ $-0.02 \cong 0 \text{ (close enough)}$ <p>So the required wire diameter (d) is</p> $d = 0.11 \text{ in}$ <p><i>Step 5.</i> Though not required, calculate the spring index (C) using Eq. (9.12).</p> $C = \frac{D}{d} = \frac{1 \text{ in}}{0.11 \text{ in}} = 9.09$ <p>which is in the range $6 \leq C \leq 12$.</p>	<p>Try a guess of (0.003)</p> $(9.8 \times 10^7)d^3 - d - 2 = 0$ $(9.8 \times 10^7)(0.003)^3 - (0.003) - 2 \stackrel{?}{=} 0$ $(2.646) - (0.003) - 2 \stackrel{?}{=} 0$ $0.643 > 0 \text{ (guess slightly too high)}$ <p>Try a guess of (0.003 - 0.0001 = 0.0029)</p> $(9.8 \times 10^7)d^3 - d - 2 = 0$ $(9.8 \times 10^7)(0.0029)^3 - (0.0029) - 2 \stackrel{?}{=} 0$ $(2.3901) - (0.0029) - 2 \stackrel{?}{=} 0$ $0.3872 > 0 \text{ (guess still too high)}$ <p>Try a guess of (0.0029 - 0.0002 = 0.0027)</p> $(9.8 \times 10^7)d^3 - d - 2 = 0$ $(9.8 \times 10^7)(0.0027)^3 - (0.0027) - 2 \stackrel{?}{=} 0$ $(1.9289) - (0.0027) - 2 \stackrel{?}{=} 0$ $-0.074 \cong 0 \text{ (close enough)}$ <p>So the required wire diameter (d) is</p> $d = 0.0027 \text{ m} = 2.7 \text{ mm}$ <p><i>Step 5.</i> Though not required, calculate the spring index (C) using Eq. (9.12).</p> $C = \frac{D}{d} = \frac{0.025 \text{ m}}{0.0027 \text{ m}} = 9.26$ <p>which is in the range $6 \leq C \leq 12$.</p>

Consider an extension of Example 2, where the deflection (y) and the shear modulus of elasticity (G) are also given and the number of active coils (N_a) is required.

U.S. Customary	SI/Metric
<p>Example 3. Suppose that the force (F) given in Example 2 causes a deflection (y). Determine the number of active coils (N_a) required, where</p> $y = 1.25 \text{ in}$ $G = 11.5 \times 10^6 \text{ lb/in}^2$ $F = 50 \text{ lb (given in Example 2)}$ $D = 1 \text{ in (given in Example 2)}$ $d = 0.11 \text{ in (determined in Example 2)}$	<p>Example 3. Suppose that the force (F) given in Example 2 causes a deflection (y). Determine the number of active coils (N_a) required, where</p> $y = 3 \text{ cm} = 0.03 \text{ m}$ $G = 80 \text{ GPa} = 80 \times 10^9 \text{ N/m}^2$ $F = 225 \text{ N (given in Example 2)}$ $D = 0.025 \text{ m (given in Example 2)}$ $d = 0.0027 \text{ m (determined in Example 2)}$

U.S. Customary	SI/Metric
<p>solution</p> <p><i>Step 1.</i> Using Eq. (9.22), determine the spring rate (k) as</p> $k = \frac{F_s}{y} = \frac{50 \text{ lb}}{1.25 \text{ in}} = 40 \text{ lb/in}$ <p><i>Step 2.</i> Substitute the spring rate (k) found in step 1 and the other given information in Eq. (9.25) to determine the number of active coils (N_a) as</p> $N_a = \frac{d^4 G}{8D^3 k}$ $N_a = \frac{(0.11 \text{ in})^4 (11.5 \times 10^6 \text{ lb/in}^2)}{(8)(1 \text{ in})^3 (40 \text{ lb/in})}$ $= \frac{1,684}{320} = 5.26 \rightarrow 6 \text{ coils}$	<p>solution</p> <p><i>Step 1.</i> Using Eq. (9.22), determine the spring rate (k) as</p> $k = \frac{F_s}{y} = \frac{225 \text{ N}}{0.03 \text{ m}} = 7500 \text{ N/m}$ <p><i>Step 2.</i> Substitute the spring rate (k) found in step 1 and the other given information in Eq. (9.25) to determine the number of active coils (N_a) as</p> $N_a = \frac{d^4 G}{8D^3 k}$ $N_a = \frac{(0.0027 \text{ m})^4 (80 \times 10^9 \text{ N/m}^2)}{(8)(0.025 \text{ m})^3 (7500 \text{ N/m})}$ $= \frac{4.25}{0.9375} = 4.53 \rightarrow 5 \text{ coils}$

9.2.3 Work and Energy

Figure 9.3 can be used to provide an expression for the work done on or by a spring, or the energy absorbed or released by a spring. If a linear spring is compressed or lengthened by a displacement (x_1), then the area under the shaded triangle in Fig. 9.4 gives the work done on or by the spring, or the energy stored or released by the spring.

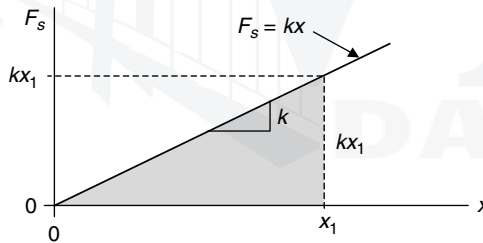

FIGURE 9.4 Work done or energy stored by a spring.

The area of the shaded triangle, denoted as (Work)_{1→2}, is given in Eq. (9.26) as

$$\text{Work}_{1 \rightarrow 2} = \frac{1}{2}(\text{base})(\text{height}) = \frac{1}{2}(x_1)(kx_1) = \frac{1}{2}kx_1^2 \quad (9.26)$$

where the displacement (x_1) is the difference between the final length and the unstretched length. Units on (Work) are (ft · lb) in the U.S. Customary and (N · m) in the SI/metric.

The subscript (1→2) on Work in Eq. (9.26) represents the fact that work is done on the spring from one position to another, meaning it is path dependent. In contrast, energy is related to a specific position, regardless of the path to get to this position.

In the absence of friction, the energy stored in or released from a spring is conservative, meaning no energy is lost if the spring is repeatedly loaded and unloaded. When energy is conservative it is called potential energy (PE), and is equal to the work (Work)_{1→2} done on the spring given in Eq. (9.26).

$$PE_{\text{spring}} = \frac{1}{2} kx_1^2 \quad (9.27)$$

Expanding these principles to a spring that is compressed from one displacement (x_1) to another displacement (x_2), or released from these same displacements, the work done on the spring to compress it, or the energy given up by the spring when released, is shown in Fig. 9.5 as the shaded trapezoidal area.

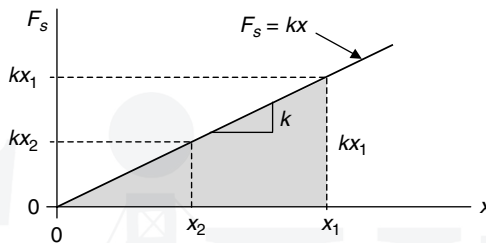

FIGURE 9.5 Work done or energy stored by a spring (two displacements).

The area of the trapezoid in Fig. 9.5 is the difference between the areas of two triangles as given in Eq. (9.28) as

$$\text{Work}_{1 \rightarrow 2} = \underbrace{\frac{1}{2} kx_1^2}_{x_1 \text{ triangle}} - \underbrace{\frac{1}{2} kx_2^2}_{x_2 \text{ triangle}} = \frac{1}{2} k(x_1^2 - x_2^2) \quad (9.28)$$

where the displacements are the differences between the final and unstretched lengths.

If the unstretched length of the spring is denoted (L_o) and the initial and final lengths are denoted (L_i) and (L_f), respectively, then the displacements (x_1) and (x_2) are given by the following two relationships:

$$\begin{aligned} x_1 &= L_i - L_o \\ x_2 &= L_f - L_o \end{aligned} \quad (9.29)$$

where (x_1) or (x_2) are either both positive or both negative. Negative values are not a problem, as the displacements are squared in Eq. (9.28).

Also, if the work done comes out positive, then the spring is doing work on the system, and if it comes out negative, then work is being done by the system on the spring.

As mentioned earlier, in the absence of friction, the cyclic loading and unloading of the spring is conservative, meaning no energy is lost, therefore, the work done given in Eq. (9.28) is equal to the stored potential energy and given as

$$PE_{\text{spring}} = \frac{1}{2} k(x_1^2 - x_2^2) \quad (9.30)$$

U.S. Customary	SI/Metric
<p>Example 4. Calculate the work done to compress a helical spring that is already compressed, where</p> $L_o = 2.0 \text{ in}$ $L_i = 1.75 \text{ in}$ $L_f = 1.25 \text{ in}$ $k = 100 \text{ lb/in}$ <p>solution</p> <p><i>Step 1.</i> Using Eq. (9.29), calculate the displacements (x_1) and (x_2) as</p> $x_1 = L_i - L_o = (1.75 \text{ in}) - (2.0 \text{ in})$ $= -0.25 \text{ in}$ $x_2 = L_f - L_o = (1.25 \text{ in}) - (2.0 \text{ in})$ $= -0.75 \text{ in}$ <p><i>Step 2.</i> Substitute the displacements (x_1) and (x_2) found in step 1 in Eq. (9.28) to give the work done as</p> $\begin{aligned} \text{Work}_{1 \rightarrow 2} &= \frac{1}{2} k (x_1^2 - x_2^2) \\ &= \frac{1}{2} (100 \text{ lb/in}) \\ &\quad \times ((-0.25 \text{ in})^2 - (-0.75 \text{ in})^2) \\ &= \frac{1}{2} (100 \text{ lb/in}) \\ &\quad \times ((0.0625 - 0.5625) \text{ in}^2) \\ &= \frac{1}{2} (100 \text{ lb/in})(-0.5 \text{ in}^2) \\ &= -25 \text{ in} \cdot \text{lb} \end{aligned}$ <p>The negative sign on the work done means work was done <i>on</i> the spring.</p>	<p>Example 4. Calculate the work done to compress a helical spring that is already compressed, where</p> $L_o = 5.0 \text{ cm} = 0.05 \text{ m}$ $L_i = 4.5 \text{ cm} = 0.045 \text{ m}$ $L_f = 3.5 \text{ cm} = 0.035 \text{ m}$ $k = 18,000 \text{ N/m}$ <p>solution</p> <p><i>Step 1.</i> Using Eq. (9.29), calculate the displacements (x_1) and (x_2) as</p> $x_1 = L_i - L_o = (0.045 \text{ m}) - (0.05 \text{ m})$ $= -0.005 \text{ m}$ $x_2 = L_f - L_o = (0.035 \text{ m}) - (0.05 \text{ m})$ $= -0.015 \text{ m}$ <p><i>Step 2.</i> Substitute the displacements (x_1) and (x_2) found in step 1 in Eq. (9.28) to give the work done as</p> $\begin{aligned} \text{Work}_{1 \rightarrow 2} &= \frac{1}{2} k (x_1^2 - x_2^2) \\ &= \frac{1}{2} (18,000 \text{ N/m}) \\ &\quad \times ((-0.005 \text{ m})^2 - (-0.015 \text{ m})^2) \\ &= \frac{1}{2} (18,000 \text{ N/m}) \\ &\quad \times ((0.000025 - 0.000225) \text{ m}^2) \\ &= \frac{1}{2} (18,000 \text{ N/m})(-0.0002 \text{ m}^2) \\ &= -1.8 \text{ N} \cdot \text{m} = -180 \text{ N} \cdot \text{cm} \end{aligned}$ <p>The negative sign on the work done means work was done <i>on</i> the spring.</p>

9.2.4 Series and Parallel Arrangements

When more than one spring is being used in a design, they are either in series, meaning one after another, or in parallel, meaning side by side, or a combination of both. These two arrangements are shown for three springs in Fig. 9.6, combined in series in (a) and combined in parallel in (b).

Using the spring rate (k) of each spring, an equivalent spring rate (k_{eq}) can be determined depending on whether the springs are in series or parallel. For the three springs in series in Fig. 9.6(a), the equivalent spring rate (k_{eq}) is given by Eq. (9.31) as

$$k_{\text{eq}} = \frac{1}{\frac{1}{k_1} + \frac{1}{k_2} + \frac{1}{k_3}} \quad (9.31)$$

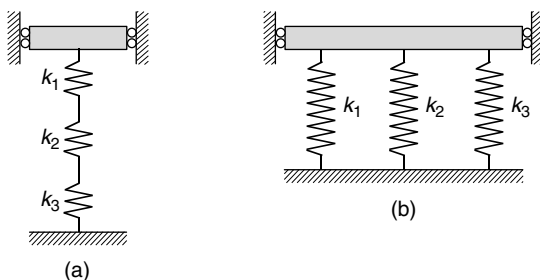

FIGURE 9.6 Series and parallel springs.

For the three springs in parallel in Fig. 9.6(b), the equivalent spring rate (k_{eq}) is given by Eq. (9.32) as

$$k_{eq} = k_1 + k_2 + k_3 \quad (9.32)$$

Notice that springs combine completely opposite to resistors in electric circuits.

U.S. Customary	SI/Metric
<p>Example 5. Two helical springs are used in series as shown in Fig. 9.6(a). Calculate the equivalent spring rate (k_{eq}), where</p> <p>$k_1 = 30 \text{ lb/in}$ $k_2 = 60 \text{ lb/in}$</p> <p>solution <i>Step 1.</i> Using Eq. (9.31), determine the equivalent spring rate (k_{eq}) as</p> $k_{eq} = \frac{1}{\frac{1}{k_1} + \frac{1}{k_2}}$ $= \frac{1}{\frac{1}{30 \text{ lb/in}} + \frac{1}{60 \text{ lb/in}}}$ $= \frac{1}{(0.033 + 0.017) \text{ in/lb}}$ $= \frac{1}{(0.05) \text{ in/lb}}$ $= 20 \text{ lb/in}$ <p>Notice that the equivalent spring rate (k_{eq}) is less than either of the two individual spring rates. This is because the weaker spring dominates the system.</p>	<p>Example 5. Two helical springs are used in series as shown in Fig. 9.6(a). Calculate the equivalent spring rate (k_{eq}), where</p> <p>$k_1 = 5,400 \text{ N/m}$ $k_2 = 10,800 \text{ N/m}$</p> <p>solution <i>Step 1.</i> Using Eq. (9.31), determine the equivalent spring rate (k_{eq}) as</p> $k_{eq} = \frac{1}{\frac{1}{k_1} + \frac{1}{k_2}}$ $= \frac{1}{\frac{1}{5,400 \text{ N/m}} + \frac{1}{10,800 \text{ N/m}}}$ $= \frac{1}{(0.0001851 + 0.0000925) \text{ m/N}}$ $= \frac{1}{(0.0002776) \text{ m/N}}$ $= 3,600 \text{ N/m}$ <p>Notice that the equivalent spring rate (k_{eq}) is less than either of the two individual spring rates. This is because the weaker spring dominates the system.</p>

U.S. Customary	SI/Metric
<p>Example 6. Suppose the two helical springs in Example 5 are used in parallel as shown in Fig. 9.6(b). Calculate the equivalent spring rate (k_{eq}), where</p> $k_1 = 30 \text{ lb/in}$ $k_2 = 60 \text{ lb/in}$ <p>solution <i>Step 1.</i> Using Eq. (9.32), determine the equivalent spring rate (k_{eq}) as</p> $k_{eq} = k_1 + k_2$ $= (30 \text{ lb/in}) + (60 \text{ lb/in})$ $= 90 \text{ lb/in}$ <p>The equivalent spring rate (k_{eq}) is greater than either of the two individual spring rates. This is because both springs are working together in the system.</p> <p>Note that these two springs will change lengths at different rates, therefore the system may rotate to accommodate this difference.</p>	<p>Example 6. Two helical springs are used in series as shown in Fig. 9.6(a). Calculate the equivalent spring rate (k_{eq}), where</p> $k_1 = 5,400 \text{ N/m}$ $k_2 = 10,800 \text{ N/m}$ <p>solution <i>Step 1.</i> Using Eq. (9.32), determine the equivalent spring rate (k_{eq}) as</p> $k_{eq} = k_1 + k_2$ $= (5,400 \text{ N/m}) + (10,800 \text{ N/m})$ $= 16,200 \text{ N/m}$ <p>The equivalent spring rate (k_{eq}) is greater than either of the two individual spring rates. This is because both springs are working together in the system.</p> <p>Note that these two springs will change lengths at different rates, therefore the system may rotate to accommodate this difference.</p>

9.2.5 Extension Springs

Extensions springs are helical springs loaded in tension. To provide a way to connect these springs into a mechanical system, a hook is usually fashioned from additional coils at each end. The stress concentrations these hooks produce must be considered in the design.

Hooks come in many designs, however all hooks follow the pattern in Fig. 9.7, where the ratio of the mean radius (r_m) to the inside radius (r_i) of the hook is the stress-concentration factor (K) given in Eq. (9.33) as

$$K = \frac{r_m}{r_i} = \frac{r_i + \frac{d}{2}}{r_i} = 1 + \frac{d}{2r_i} \quad (9.33)$$

where as the wire diameter (d) increases, or the inside radius (r_i) decreases, or both, the stress-concentration factor (K) increases.

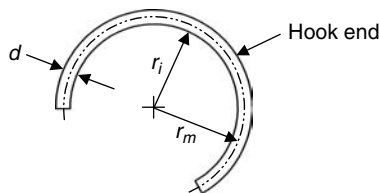

FIGURE 9.7 Extension spring hook geometry.

The free, or unstretched, length (L_o) of an extension spring is the body length (L_B) plus two times the hook distance (L_{hook}), given in Eq. (9.34) as

$$L_o = L_B + 2L_{\text{hook}} \quad (9.34)$$

where the body length (L_B) is given by Eq. (9.35) as

$$L_B = (N_a + 1)d \quad (9.35)$$

The presence of the stress-concentration factor (K) given in Eq. (9.33) prevents the hooks from being designed as strong as the main coils of the spring.

U.S. Customary	SI/Metric
<p>Example 7. Suppose circular hooks are added to the ends of the cylindrical helical spring designed in Example 2. Determine the stress-concentration factor (K) for the design, where</p> <p>$D = 1$ in (given in Example 2) $d = 0.11$ in (determined in Example 2) $r_i = (D - d)/2 = 0.445$ in</p> <p>solution <i>Step 1.</i> Using Eq. (9.33), determine the stress-concentration factor (K) as</p> $K = 1 + \frac{d}{2r_i} = 1 + \frac{0.11 \text{ in}}{2(0.445 \text{ in})}$ $= 1 + (0.124) = 1.12$ <p>This means the stress at the hook ends are a little over 12 percent greater than the stress in main coils.</p>	<p>Example 7. Suppose circular hooks are added to the ends of the cylindrical helical spring designed in Example 2. Determine the stress-concentration factor (K) for the design, where</p> <p>$D = 0.025$ m (given in Example 2) $d = 0.0027$ m (determined in Example 2) $r_i = (D - d)/2 = 0.01115$ m</p> <p>solution <i>Step 1.</i> Using Eq. (9.33), determine the stress-concentration factor (K) as</p> $K = 1 + \frac{d}{2r_i} = 1 + \frac{0.0027 \text{ m}}{2(0.01115 \text{ m})}$ $= 1 + (0.121) = 1.12$ <p>This means the stress at the hook ends are a little over 12 percent greater than the stress in main coils.</p>

9.2.6 Compression Springs

As the name implies, compression springs are helical springs loaded in compression. There are four main types of ends for compression springs: (1) plain, (2) squared, (3) plain and ground, and (4) squared and ground. A spring with plain ends has an uninterrupted helix angle at its ends, whereas a spring with squared ends has the helix angle flattened to zero at its ends. For both plain and squared types, ends that are ground flush improve load transfer, particularly with squared and ground ends.

Additional coils must be added to the design of a helical spring if the ends are not plain. Table 9.1 gives a summary of the additional coils needed for each type. In Table 9.1, a term appears denoted (p) for pitch. For a cylindrical helical spring with plain ends, the pitch (p) is defined as

$$p = \frac{L_o - d}{N_a} \quad (9.36)$$

where the units of pitch are length per number of active coils. The pitch (p) of a helical spring is used to determine its free length.

TABLE 9.1 Summary of Additional Coils for Compression Springs

Type	Total coils	Solid length	Pitch (p)	Free length (L_o)
Plain	N_a	$(N_a + 1)d$	$(L_o - d)/N_a$	$pN_a + d$
Squared	$N_a + 2$	$(N_a + 3)d$	$(L_o - 3d)/N_a$	$pN_a + 3d$
Plain & Ground	$N_a + 1$	$(N_a + 1)d$	$L_o/(N_a + 1)$	$p(N_a + 1)$
Squared & Ground	$N_a + 2$	$(N_a + 2)d$	$(L_o - 2d)/N_a$	$pN_a + 2d$

Source: *Design Handbook*, Associated Spring—Barnes Group, Bristol, Conn., 1981.

Stability. In Chap. 6 column buckling was discussed where if the compressive stress (σ_{axial}) became greater than a critical stress (σ_{cr}), depending on the slenderness ratio of the column, the design would be unsafe. Similarly, as the length of a cylindrical helical spring increases, buckling can occur at a critical deflection (y_{cr}) given by Eq. (9.37) as

$$y_{cr} = L_o C_1 \left[1 - \left(1 - \frac{\lambda_{eff}^2}{C_2} \right)^{1/2} \right] \tag{9.37}$$

where (λ_{eff}) is the effective slenderness ratio and given by Eq. (9.38) as

$$\lambda_{eff} = \frac{\alpha L_o}{D} \tag{9.38}$$

and (α) is an end-condition constant.

Values for four typical end conditions for helical springs are given in Table 9.2. Notice the similarity with the coefficient (C_{ends}) for slender columns given in Chap. 6.

TABLE 9.2 Summary of the End-Condition Constant (α)

α	End condition
0.5	Both ends supported on flat parallel surfaces
0.7	One end supported on flat surface, other end hinged
1	Both ends hinged
2	One end support on flat surface, other end free

The constants (C_1) and (C_2) in Eq. (9.37) are called elastic constants and are given by the following relationships:

$$C_1 = \frac{E}{2(E - G)} \tag{9.39}$$

$$C_2 = \frac{2\pi^2(E - G)}{2G + E} \tag{9.40}$$

To avoid taking the square root of a negative number in Eq. (9.37), the ratio (λ_{eff}^2/C_2) must be less than or equal to 1. This means the free length (L_o) must be less than or equal to the quantity on the right-hand side of Eq. (9.41).

$$L_o \leq \frac{\pi D}{\alpha} \left[\frac{2(E - G)}{2G + E} \right]^{1/2} \tag{9.41}$$

For springs made of steel, this value of the free length (L_o) is given by Eq. (9.42), which is dependent only on the mean diameter (D) and the end-constant (α).

$$L_o \leq 2.63 \frac{D}{\alpha} \quad (9.42)$$

U.S. Customary	SI/Metric
<p>Example 8. Determine the critical deflection (y_{cr}) for a steel compression helical spring positioned between two flat parallel surfaces, where</p> <p>$L_o = 3$ in $D = 1$ in $E = 30 \times 10^6$ lb/in² (steel) $G = 11.5 \times 10^6$ lb/in² (steel)</p> <p>solution <i>Step 1.</i> Using the guidelines in Table 9.2, choose the end-condition (α) as</p> $\alpha = 0.5$ <p><i>Step 2.</i> Using the end-condition (α) from step 1 and the given information, calculate the effective slenderness ratio (λ_{eff}) using Eq. (9.38) as</p> $\lambda_{eff} = \frac{\alpha L_o}{D} = \frac{(0.5)(3 \text{ in})}{(1 \text{ in})} = 1.5$ <p><i>Step 3.</i> Using the given moduli of elasticities (E) and (G), calculate the elastic constants (C_1) and (C_2) as</p> $C_1 = \frac{E}{2(E - G)}$ $= \frac{30 \times 10^6 \text{ lb/in}^2}{2(30 - 11.5) \times 10^6 \text{ lb/in}^2}$ $= \frac{30 \times 10^6 \text{ lb/in}^2}{37 \times 10^6 \text{ lb/in}^2} = 0.81$ $C_2 = \frac{2\pi^2(E - G)}{2G + E}$ $= \frac{2\pi^2(30 - 11.5) \times 10^6 \text{ lb/in}^2}{[2(11.5) + 30] \times 10^6 \text{ lb/in}^2}$ $= \frac{365 \times 10^6 \text{ lb/in}^2}{53 \times 10^6 \text{ lb/in}^2} = 6.9$ <p><i>Step 4.</i> Using the effective slenderness ratio (λ_{eff}) found in step 2, the elastic constants (C_1) and (C_2) found in step 3, and the free length (L_o) in Eq. (9.37) to determine the critical</p>	<p>Example 8. Determine the critical deflection (y_{cr}) for a steel compression helical spring positioned between two flat parallel surfaces, where</p> <p>$L_o = 7.5$ cm $D = 2.5$ cm $E = 210$ GPa = 210×10^9 N/m² (steel) $G = 80.5$ GPa = 80.5×10^9 N/m² (steel)</p> <p>solution <i>Step 1.</i> Using the guidelines in Table 9.2, choose the end-condition (α) as</p> $\alpha = 0.5$ <p><i>Step 2.</i> Using the end-condition (α) from step 1 and the given information, calculate the effective slenderness ratio (λ_{eff}) using Eq. (9.38) as</p> $\lambda_{eff} = \frac{\alpha L_o}{D} = \frac{(0.5)(7.5 \text{ cm})}{(2.5 \text{ cm})} = 1.5$ <p><i>Step 3.</i> Using the given moduli of elasticities (E) and (G), calculate the elastic constants (C_1) and (C_2) as</p> $C_1 = \frac{E}{2(E - G)}$ $= \frac{210 \times 10^9 \text{ N/m}^2}{2(210 - 80.5) \times 10^9 \text{ N/m}^2}$ $= \frac{210 \times 10^9 \text{ N/m}^2}{259 \times 10^9 \text{ N/m}^2} = 0.81$ $C_2 = \frac{2\pi^2(E - G)}{2G + E}$ $= \frac{2\pi^2(210 - 80.5) \times 10^9 \text{ N/m}^2}{[2(80.5) + 210] \times 10^9 \text{ N/m}^2}$ $= \frac{2,556 \times 10^9 \text{ N/m}^2}{371 \times 10^9 \text{ N/m}^2} = 6.9$ <p><i>Step 4.</i> Using the effective slenderness ratio (λ_{eff}) found in step 2, the elastic constants (C_1) and (C_2) found in step 3, and the free length (L_o) in Eq. (9.37) to determine the critical</p>

U.S. Customary	SI/Metric
deflection (y_{cr}) as $y_{cr} = L_o C_1 \left[1 - \left(1 - \frac{\lambda_{eff}^2}{C_2} \right)^{1/2} \right]$ $= (3 \text{ in})(0.81) \left[1 - \left(1 - \frac{(1.5)^2}{6.9} \right)^{1/2} \right]$ $= (2.43 \text{ in})[1 - (1 - 0.326)^{1/2}]$ $= (2.43 \text{ in})[1 - (0.821)]$ $= (2.43 \text{ in})(0.179) = 0.44 \text{ in}$ <p>Note that this critical deflection (y_{cr}) represents almost a 15 percent reduction in length before the design is unsafe.</p>	deflection (y_{cr}) as $y_{cr} = L_o C_1 \left[1 - \left(1 - \frac{\lambda_{eff}^2}{C_2} \right)^{1/2} \right]$ $= (7.5 \text{ cm})(0.81) \left[1 - \left(1 - \frac{(1.5)^2}{6.9} \right)^{1/2} \right]$ $= (7.5 \text{ cm})[1 - (1 - 0.326)^{1/2}]$ $= (7.5 \text{ cm})[1 - (0.821)]$ $= (7.5 \text{ cm})(0.179) = 1.3 \text{ cm}$ <p>Note that this critical deflection (y_{cr}) represents just over a 17 percent reduction in length before the design is unsafe.</p>

9.2.7 Critical Frequency

Helical springs, such as those used in the valve trains of internal combustion engines, can fail if the frequency of loading coincides with the natural, or critical, frequency of the spring, called resonance. Different end-conditions, like those summarized in Table 9.2, produce different critical frequencies. To avoid problems, it is usually recommended that the spring design be such that its critical frequency is 15 to 20 times the frequency of the applied cyclic loading frequency.

For a helical spring positioned between flat parallel surfaces, where one of the surfaces is driven by a sinusoidal forcing function, the critical frequency (f_{cr}) in cycles per second (Hz) is given by Eq. (9.43) as

$$f_{cr} = \frac{1}{2} \sqrt{\frac{k}{m}} \quad (9.43)$$

where (m) is the mass of the active part of the spring.

The mass (m) can be found by multiplying the density (ρ) of the spring material times its volume. The development of an expression for the mass of the active part of a spring is given by Eq. (9.44) as

$$\begin{aligned}
 m &= \text{density} \times \text{volume} = \rho A \ell \\
 &= (\rho) \underbrace{\left(\frac{\pi d^2}{4} \right)}_A \underbrace{(\pi D N_a)}_\ell \\
 &= \frac{\rho \pi^2 d^2 D N_a}{4}
 \end{aligned} \quad (9.44)$$

Substituting the expression for the the number of active coils (N_a) from Eq. (9.25) in Eq. (9.44) for the mass (m) of the spring gives

$$m = \frac{\rho\pi^2 d^2 DN_a}{4} = \frac{\rho\pi^2 d^2 D}{4} \frac{d^4 G}{8D^3 k} = \frac{\rho\pi^2 d^6 G}{32D^2 k} \quad (9.45)$$

Substitute the expression for the mass (m) from Eq. (9.45) into the expression for the critical frequency (f_{cr}) in Eq. (9.43) to give

$$\begin{aligned} f_{cr} &= \frac{1}{2} \sqrt{\frac{k}{m}} = \frac{1}{2} \sqrt{\frac{k}{\frac{\rho\pi^2 d^6 G}{32D^2 k}}} = \frac{1}{2} \sqrt{\frac{32D^2 k^2}{\rho\pi^2 d^6 G}} \\ &= \frac{Dk}{\pi d^3} \sqrt{\frac{8}{\rho G}} \end{aligned} \quad (9.46)$$

As stated earlier, multiply the critical frequency by 15 to 20 to avoid resonance with the frequency of the cyclic loading on the spring.

U.S. Customary	SI/Metric
<p>Example 9. Determine the limiting frequency ($f_{limiting}$) of the cyclic loading on a helical spring, where</p> <p>$D = 1.5$ in $d = 0.125$ in $k = 50$ lb/in $\rho = 15.2$ slug/ft³ = 8.8×10^{-3} slug/in³ $G = 11.5 \times 10^6$ lb/in² (steel)</p> <p>solution <i>Step 1.</i> As the units are somewhat awkward, first calculate the term (ρG) as</p> $\begin{aligned} \rho G &= \left(8.8 \times 10^{-3} \frac{\text{slug}}{\text{in}^3}\right) \left(11.5 \times 10^6 \frac{\text{lb}}{\text{in}^2}\right) \\ &= 1.012 \times 10^5 \frac{\text{slug} \cdot \text{lb}}{\text{in}^5} \\ &= 1.012 \times 10^5 \frac{(\text{lb} \cdot \text{s}^2/\text{ft}) \cdot \text{lb}}{\text{in}^5} \\ &= 1.012 \times 10^5 \frac{\text{s}^2 \cdot \text{lb}^2}{\text{ft} \cdot \text{in}^5} \times \frac{1 \text{ ft}}{12 \text{ in}} \\ &= 8.43 \times 10^3 \frac{\text{lb}^2 \cdot \text{s}^2}{\text{in}^6} \end{aligned}$	<p>Example 9. Determine the limiting frequency ($f_{limiting}$) of the cyclic loading on a helical spring, where</p> <p>$D = 4$ cm = 0.04 m $d = 0.3$ cm = 0.003 m $k = 9,000$ N/m $\rho = 7,850$ kg/m³ $G = 80.5$ GPa = 80.5×10^9 N/m² (steel)</p> <p>solution <i>Step 1.</i> As the units are somewhat awkward, first calculate the term (ρG) as</p> $\begin{aligned} \rho G &= \left(7,850 \frac{\text{kg}}{\text{m}^3}\right) \left(80.5 \times 10^9 \frac{\text{N}}{\text{m}^2}\right) \\ &= 6.32 \times 10^{14} \frac{\text{kg} \cdot \text{N}}{\text{m}^5} \\ &= 6.32 \times 10^{14} \frac{(\text{N} \cdot \text{s}^2/\text{m}) \cdot \text{N}}{\text{m}^5} \\ &= 6.32 \times 10^{14} \frac{\text{s}^2 \cdot \text{N}^2}{\text{m}^6} \\ &= 6.32 \times 10^{14} \frac{\text{N}^2 \cdot \text{s}^2}{\text{m}^6} \end{aligned}$

U.S. Customary	SI/Metric
<p><i>Step 2.</i> Substitute the term (ρG) found in step 1 and the other given information in Eq. (9.46) to give the critical frequency (f_{cr}) as</p> $f_{cr} = \frac{Dk}{\pi d^3} \sqrt{\frac{8}{\rho G}} = \frac{(1.5 \text{ in})(50 \text{ lb/in})}{\pi(0.125 \text{ in})^3}$ $\times \sqrt{\frac{8}{8.43 \times 10^3 \frac{\text{lb} \cdot \text{s}^2}{\text{in}^6}}}$ $= \frac{75 \text{ lb}}{0.006 \text{ in}^3} \sqrt{9.49 \times 10^{-4} \frac{\text{in}^6}{\text{lb}^2 \cdot \text{s}^2}}$ $= \left(12,500 \frac{\text{lb}}{\text{in}^3}\right) \left(3.08 \times 10^{-2} \frac{\text{in}^3}{\text{lb} \cdot \text{s}}\right)$ $= 385 \frac{\text{cycle}}{\text{s}} = 385 \text{ Hz}$ <p><i>Step 3.</i> Divide the critical frequency (f_{cr}) found in step 2 by 20 to obtain the limiting frequency of the cyclic loading.</p> $f_{\text{limiting}} = \frac{f_{cr}}{20} = \frac{385 \text{ Hz}}{20} \cong 19 \text{ Hz}$ <p>Cyclic loading frequencies greater than this value are unsafe.</p>	<p><i>Step 2.</i> Substitute the term (ρG) found in step 1 and the other given information in Eq. (9.46) to give the critical frequency (f_{cr}) as</p> $f_{cr} = \frac{Dk}{\pi d^3} \sqrt{\frac{8}{\rho G}} = \frac{(0.04 \text{ m})(9,000 \text{ N/m})}{\pi(0.003 \text{ m})^3}$ $\times \sqrt{\frac{8}{6.32 \times 10^{14} \frac{\text{N}^2 \cdot \text{s}^2}{\text{m}^6}}}$ $= \frac{360 \text{ N}}{8.5 \times 10^{-8} \text{ m}^3} \sqrt{1.3 \times 10^{-14} \frac{\text{m}^6}{\text{N}^2 \cdot \text{s}^2}}$ $= \left(4.2 \times 10^9 \frac{\text{N}}{\text{m}^3}\right) \left(1.1 \times 10^{-7} \frac{\text{m}^3}{\text{N} \cdot \text{s}}\right)$ $= 462 \frac{\text{cycle}}{\text{s}} = 462 \text{ Hz}$ <p><i>Step 3.</i> Divide the critical frequency (f_{cr}) found in step 2 by 20 to obtain the limiting frequency of the cyclic loading.</p> $f_{\text{limiting}} = \frac{f_{cr}}{20} = \frac{462 \text{ Hz}}{20} \cong 23 \text{ Hz}$ <p>Cyclic loading frequencies greater than this value are unsafe.</p>

9.2.8 Fatigue Loading

Rarely are helical springs *not* subjected to fatigue loading. The number of cycles may only be in hundreds or thousands, but usually they must be designed for millions and millions of cycles such that an infinite life is desired.

Helical springs may be subjected to completely reversed loading, where the mean shear stress (τ_m) is zero; however, as this type of spring is installed with a preload, the spring is usually subjected to fluctuating loading. The fluctuating loading may be compressive or tensile, but never both.

If the maximum force on the spring is denoted as (F_{max}) and the minimum force is denoted as (F_{min}), whether they are compressive or tensile, then the mean force (F_m) and alternating force (F_a) are given by the relationships in Eqs. (9.47) and (9.48) as

$$F_m = \frac{F_{\text{max}} + F_{\text{min}}}{2} \quad (9.47)$$

$$F_a = \frac{F_{\text{max}} - F_{\text{min}}}{2} \quad (9.48)$$

In Chap. 7 it was shown that any stress-concentration factors are applied only to the alternating stresses. Therefore, using Eq. (9.13) the mean shear stress (τ_m) is given by Eq. (9.49) as

$$\tau_m = K_s \frac{8F_m D}{\pi d^3} \quad (9.49)$$

where the shear-stress correction factor (K_s) is given by Eq. (9.14).

Using the Bergsträsser factor (K_B) given by Eq. (9.16) in place of the shear-stress correction factor (K_s), the alternating shear stress (τ_a) is given by Eq. (9.50) as

$$\tau_a = K_B \frac{8F_a D}{\pi d^3} \tag{9.50}$$

Also from Chap. 7, the Goodman theory for fluctuating torsional loading is applicable where the factor of safety (n) for a safe design was given by Eq. (7.34) and repeated here as

$$\frac{\tau_a}{S_e} + \frac{\tau_m}{S_{us}} = \frac{1}{n} \tag{7.34}$$

where the endurance limit (S_e) is calculated as usual using the Marin formula in Eq. (7.7) with the load type factor (k_c) equal to (0.577), and the ultimate shear stress (S_{us}) found from the relationship in Eq. (7.33), repeated here.

$$S_{us} = (0.67)S_{ut} \tag{7.33}$$

The Goodman theory given in Eq. (7.34) can be represented graphically and was shown in Fig. 7.24, repeated here.

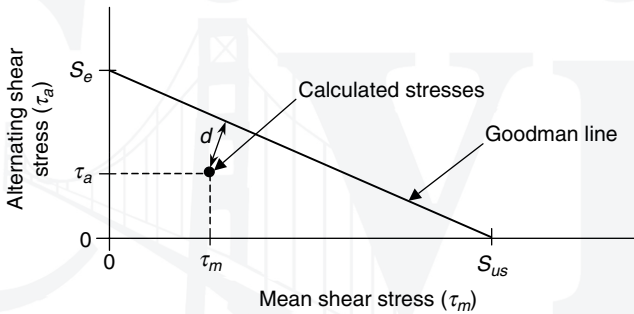

FIGURE 7.24 Goodman theory for fluctuating torsional loading.

The perpendicular distance (d) to the Goodman line in Fig. 7.24 represents how close the factor-of-safety (n) is to the value of 1.

Once the mean shear stress (τ_m), the alternating shear stress (τ_a), the endurance limit (S_e), and the ultimate shear strength (S_{us}) are known, the factor-of-safety (n) for the design can be determined either mathematically using Eq. (7.34) or graphically using Fig. 7.24.

U.S. Customary	SI/Metric
<p>Example 10. Determine the factor-of-safety (n) against fatigue for a helical spring under fluctuating loads, where</p> <p>$F_{\min} = 10$ lb $F_{\max} = 40$ lb $D = 0.9$ in $d = 0.1$ in $S_e = 60$ kpsi $S_{us} = 140$ kpsi</p>	<p>Example 10. Determine the factor-of-safety (n) against fatigue for a helical spring under fluctuating loads, where</p> <p>$F_{\min} = 45$ N $F_{\max} = 175$ N $D = 2.2$ cm = 0.022 m $d = 0.2$ cm = 0.002 m $S_e = 420$ MPa $S_{us} = 980$ MPa</p>

U.S. Customary	SI/Metric
<p>solution</p> <p><i>Step 1.</i> Using Eq. (9.12), calculate the spring index (C) as</p> $C = \frac{D}{d} = \frac{0.9 \text{ in}}{0.1 \text{ in}} = 9$ <p><i>Step 2.</i> Using Eq. (9.14), calculate the shear-stress correction factor (K_s) as</p> $K_s = \frac{1}{2C} + 1 = \frac{1}{2(9)} + 1$ $= (0.056) + 1 = 1.056$ <p><i>Step 3.</i> Using Eq. (9.16), calculate the Bergsträsser factor (K_B) as</p> $K_B = \frac{4C + 2}{4C - 3} = \frac{4(9) + 2}{4(9) - 3} = \frac{38}{33} = 1.152$ <p><i>Step 4.</i> Use Eqs. (9.47) and (9.48) to find the mean and alternating spring forces.</p> $F_m = \frac{F_{\max} + F_{\min}}{2} = \frac{(40 \text{ lb}) + (10 \text{ lb})}{2}$ $= \frac{50 \text{ lb}}{2} = 25 \text{ lb}$ $F_a = \frac{F_{\max} - F_{\min}}{2} = \frac{(40 \text{ lb}) - (10 \text{ lb})}{2}$ $= \frac{30 \text{ lb}}{2} = 15 \text{ lb}$ <p><i>Step 5.</i> Use the shear-stress correction factor (K_s) found in step 2 in Eq. (9.49) to find the mean shear stress (τ_m).</p> $\tau_m = K_s \frac{8F_m D}{\pi d^3}$ $= (1.056) \frac{(8)(25 \text{ lb})(0.9 \text{ in})}{\pi (0.1 \text{ in})^3}$ $= (1.056) \frac{180 \text{ lb}}{0.00314 \text{ in}^2}$ $= (1.056)(57.3 \text{ kpsi})$ $= 60.5 \text{ kpsi}$ <p><i>Step 6.</i> Use the Bergstrasser factor (K_B) found in step 3 in Eq. (9.50) to find the alternating shear stress (τ_a).</p> $\tau_a = K_B \frac{8F_a D}{\pi d^3}$ $= (1.152) \frac{(8)(15 \text{ lb})(0.9 \text{ in})}{\pi (0.1 \text{ in})^3}$ $= (1.152) \frac{108 \text{ lb}}{0.00314 \text{ in}^2}$ $= (1.152)(34.4 \text{ kpsi})$ $= 39.6 \text{ kpsi}$	<p>solution</p> <p><i>Step 1.</i> Using Eq. (9.12), calculate the spring index (C) as</p> $C = \frac{D}{d} = \frac{0.022 \text{ m}}{0.002 \text{ m}} = 11$ <p><i>Step 2.</i> Using Eq. (9.14), calculate the shear-stress correction factor (K_s) as</p> $K_s = \frac{1}{2C} + 1 = \frac{1}{2(11)} + 1$ $= (0.045) + 1 = 1.045$ <p><i>Step 3.</i> Using Eq. (9.16), calculate the Bergsträsser factor (K_B) as</p> $K_B = \frac{4C + 2}{4C - 3} = \frac{4(11) + 2}{4(11) - 3} = \frac{46}{41} = 1.122$ <p><i>Step 4.</i> Use Eqs. (9.47) and (9.48) to find the maximum and minimum spring forces.</p> $F_m = \frac{F_{\max} + F_{\min}}{2} = \frac{(175 \text{ N}) + (45 \text{ N})}{2}$ $= \frac{220 \text{ N}}{2} = 110 \text{ N}$ $F_a = \frac{F_{\max} - F_{\min}}{2} = \frac{(175 \text{ N}) - (45 \text{ N})}{2}$ $= \frac{130 \text{ N}}{2} = 65 \text{ N}$ <p><i>Step 5.</i> Use the shear-stress correction factor (K_s) found in step 2 in Eq. (9.49) to find the mean shear stress (τ_m).</p> $\tau_m = K_s \frac{8F_m D}{\pi d^3}$ $= (1.045) \frac{(8)(110 \text{ N})(0.022 \text{ m})}{\pi (0.002 \text{ m})^3}$ $= (1.045) \frac{19.36 \text{ N}}{0.000000025 \text{ m}^2}$ $= (1.045)(770.3 \text{ MPa})$ $= 805 \text{ MPa}$ <p><i>Step 6.</i> Use the Bergstrasser factor (K_B) found in step 3 in Eq. (9.50) to find the alternating shear stress (τ_a).</p> $\tau_a = K_B \frac{8F_a D}{\pi d^3}$ $= (1.122) \frac{(8)(65 \text{ N})(0.022 \text{ m})}{\pi (0.002 \text{ m})^3}$ $= (1.122) \frac{11.44 \text{ N}}{0.000000025 \text{ m}^2}$ $= (1.122)(455.2 \text{ MPa})$ $= 511 \text{ MPa}$

U.S. Customary	SI/Metric
<p><i>Step 7.</i> Substitute the mean shear stress (τ_m) from step 5 and the alternating shear stress (τ_a) from step 6, and the given endurance limit (S_e) and ultimate shear stress (S_{us}) in the Goodman theory given in Eq. (7.34) as</p> $\frac{\tau_a}{S_e} + \frac{\tau_m}{S_{us}} = \frac{1}{n}$ $\frac{39.6 \text{ kpsi}}{60 \text{ kpsi}} + \frac{60.5 \text{ kpsi}}{140 \text{ kpsi}} = \frac{1}{n}$ $(0.660) + (0.432) = \frac{1}{n}$ $1.092 = \frac{1}{n}$ $n = \frac{1}{1.092} = 0.92 \text{ (unsafe)}$ <p>The fact that the factor-of-safety (n) is less than 1, means the spring must be redesigned.</p>	<p><i>Step 7.</i> Substitute the mean shear stress (τ_m) from step 5 and the alternating shear stress (τ_a) from step 6, and the given endurance limit (S_e) and ultimate shear stress (S_{us}) in the Goodman theory given in Eq. (7.34) as</p> $\frac{\tau_a}{S_e} + \frac{\tau_m}{S_{us}} = \frac{1}{n}$ $\frac{511 \text{ MPa}}{420 \text{ MPa}} + \frac{805 \text{ MPa}}{980 \text{ MPa}} = \frac{1}{n}$ $(1.217) + (0.821) = \frac{1}{n}$ $2.038 = \frac{1}{n}$ $n = \frac{1}{2.038} = 0.49 \text{ (very unsafe)}$ <p>The fact that the factor-of-safety (n) is much less than 1, means the spring must be re-designed.</p>

9.3 FLYWHEELS

Flywheels store and release the energy of rotation, called inertial energy. The primary purpose of a flywheel is to regulate the speed of a machine. It does this through the amount of inertia contained in the flywheel, specifically the mass moment of inertia. Flywheels are typically mounted onto one of the axes of the machine, integral with one of the rotating shafts. Therefore, it is the mass moment of inertia about this axis that is the most important design parameter. As stated in the introduction to this chapter, too much inertia in the flywheel design and the system will be sluggish and unresponsive, too little inertia and the system will lose momentum over time. The inertia has to be just right! Determining the right amount of inertia is the main purpose of the discussion that follows.

9.3.1 Inertial Energy of a Flywheel

Shown in Fig. 9.8 is a solid disk flywheel integral to a rotating shaft supported by appropriate bearings at each end. The applied torque (T) produces an angular acceleration, denoted (α), which in turn produces an angular velocity, denoted by (ω).

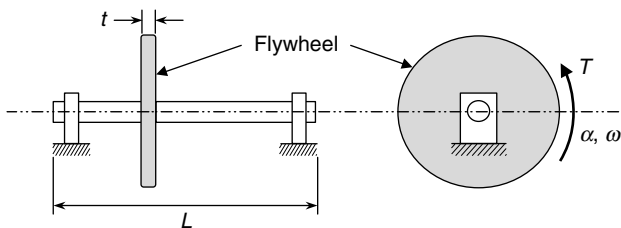

FIGURE 9.8 Solid disk flywheel on a rotating shaft.

The torque (T) can vary over time; therefore, the angular acceleration (α) and angular velocity (ω) must also vary over time.

The relationship between the torque (T) and the angular acceleration (α) for a flywheel and shaft assembly rotating about a fixed axis is given by Eq. (9.51) as

$$T = I_{\text{total}} \alpha = (I_{\text{flywheel}} + I_{\text{shaft}}) \alpha \quad (9.51)$$

where (I_{total}) is the *total* mass moment of inertia, which is the sum of the mass moment of inertia of the flywheel (I_{flywheel}) and the mass moment of inertia of the shaft (I_{shaft}), both calculated about the axis of rotation.

For a solid disk flywheel with an outside radius (r_o) and inside radius (r_i) mounted on a shaft with an outside radius equal to the inside radius of the flywheel, the mass moments of inertia (I_{flywheel}) and (I_{shaft}) are given by the following two formulas as

$$I_{\text{flywheel}} = \frac{1}{2} \rho \pi t (r_o^2 - r_i^2)^2 \quad (9.52)$$

$$I_{\text{shaft}} = \frac{1}{2} \rho \pi L r_i^4 \quad (9.53)$$

where (t) is the thickness of the flywheel and (L) is the length of the shaft, and where the density (ρ) of the flywheel and shaft are assumed to be the same.

U.S. Customary	SI/Metric
<p>Example 1. Calculate the angular acceleration (α) produced by a torque (T) on a steel solid disk flywheel and shaft assembly, where</p> <p>$T = 20 \text{ ft} \cdot \text{lb}$ $\rho = 15.2 \text{ slug/ft}^3$ (steel) $r_o = 18 \text{ in} = 1.5 \text{ ft}$ $r_i = 1.5 \text{ in} = 0.125 \text{ ft}$ $t = 3 \text{ in} = 0.25 \text{ ft}$ $L = 4 \text{ ft}$</p> <p>solution <i>Step 1.</i> Calculate the mass moment of inertia (I_{flywheel}) for a solid disk flywheel using Eq. (9.52).</p> $\begin{aligned} I_{\text{flywheel}} &= \frac{1}{2} \rho \pi t (r_o^2 - r_i^2)^2 \\ &= \frac{1}{2} \left(15.2 \frac{\text{slug}}{\text{ft}^3} \right) \pi (0.25 \text{ ft}) \\ &\quad \times [(1.5 \text{ ft})^2 - (0.125 \text{ ft})^2]^2 \\ &= \left(5.97 \frac{\text{slug}}{\text{ft}^2} \right) \\ &\quad \times [(2.25 - 0.0156) \text{ ft}^2]^2 \\ &= \left(5.97 \frac{\text{slug}}{\text{ft}^2} \right) [4.99 \text{ ft}^4] \\ &= 29.80 \text{ slug} \cdot \text{ft}^2 \end{aligned}$	<p>Example 1. Calculate the angular acceleration (α) produced by a torque (T) on a steel solid disk flywheel and shaft assembly, where</p> <p>$T = 30 \text{ N} \cdot \text{m}$ $\rho = 7,850 \text{ kg/m}^3$ (steel) $r_o = 45 \text{ cm} = 0.45 \text{ m}$ $r_i = 4 \text{ cm} = 0.04 \text{ m}$ $t = 8 \text{ cm} = 0.08 \text{ m}$ $L = 1.35 \text{ m}$</p> <p>solution <i>Step 1.</i> Calculate the mass moment of inertia (I_{flywheel}) for a solid disk flywheel using Eq. (9.52).</p> $\begin{aligned} I_{\text{flywheel}} &= \frac{1}{2} \rho \pi t (r_o^2 - r_i^2)^2 \\ &= \frac{1}{2} \left(7,850 \frac{\text{kg}}{\text{m}^3} \right) \pi (0.08 \text{ m}) \\ &\quad \times [(0.45 \text{ m})^2 - (0.04 \text{ m})^2]^2 \\ &= \left(986.5 \frac{\text{kg}}{\text{m}^2} \right) \\ &\quad \times [(0.2025 - 0.0016) \text{ m}^2]^2 \\ &= \left(986.5 \frac{\text{kg}}{\text{m}^2} \right) [0.0404 \text{ m}^4] \\ &= 39.85 \text{ kg} \cdot \text{m}^2 \end{aligned}$

U.S. Customary	SI/Metric
<p><i>Step 2.</i> Calculate the mass moment of inertia (I_{shaft}) for the solid circular shaft using Eq. (9.53).</p> $I_{\text{shaft}} = \frac{1}{2} \rho \pi L r_i^4$ $= \frac{1}{2} \left(15.2 \frac{\text{slug}}{\text{ft}^3} \right) \pi (4 \text{ ft})$ $\times [(0.125 \text{ ft})^4]$ $= \left(95.5 \frac{\text{slug}}{\text{ft}^2} \right) [0.000244 \text{ ft}^4]$ $= 0.02 \text{ slug} \cdot \text{ft}^2$ <p><i>Step 3.</i> Combine the mass moment of inertia of the flywheel (I_{flywheel}) found in step 1 with the mass moment of inertia of the shaft (I_{flywheel}) found in step 2 to give the total mass moment of inertia (I_{total}) as</p> $I_{\text{total}} = I_{\text{flywheel}} + I_{\text{shaft}}$ $= [(29.80) + (0.02) \text{ slug} \cdot \text{ft}^2]$ $= 29.82 \text{ slug} \cdot \text{ft}^2$ <p>Notice that the contribution to the total mass moment of inertia from the shaft is almost negligible. This is because mass farther away from the axis counts more, in fact a function of the distance squared.</p> <p><i>Step 4.</i> Substitute the total mass moment of inertia (I_{total}) found in step 3 and the given torque (T) in Eq. (9.51).</p> $T = I_{\text{total}} \alpha$ $20 \text{ ft} \cdot \text{lb} = (29.82 \text{ slug} \cdot \text{ft}^2) \alpha$ <p><i>Step 5.</i> Solve for the angular acceleration (α) from step 4.</p> $\alpha = \frac{20 \text{ ft} \cdot \text{lb}}{29.82 \text{ slug} \cdot \text{ft}^2} = 0.67 \frac{\text{lb}}{\text{slug} \cdot \text{ft}}$ $= 0.67 \frac{\text{slug} \cdot \text{ft}/\text{sec}^2}{\text{slug} \cdot \text{ft}} = 0.67 \frac{\text{rad}}{\text{s}^2}$	<p><i>Step 2.</i> Calculate the mass moment of inertia (I_{shaft}) for the solid circular shaft using Eq. (9.53).</p> $I_{\text{shaft}} = \frac{1}{2} \rho \pi L r_i^4$ $= \frac{1}{2} \left(7,850 \frac{\text{kg}}{\text{m}^3} \right) \pi (1.35 \text{ m})$ $\times [(0.04 \text{ m})^4]$ $= \left(16,650 \frac{\text{kg}}{\text{m}^2} \right) [0.0000025 \text{ m}^4]$ $= 0.04 \text{ kg} \cdot \text{m}^2$ <p><i>Step 3.</i> Combine the mass moment of inertia of the flywheel (I_{flywheel}) found in step 1 with the mass moment of inertia of the shaft (I_{shaft}) found in step 2 to give the total mass moment of inertia (I_{total}) as</p> $I_{\text{total}} = I_{\text{flywheel}} + I_{\text{shaft}}$ $= [(39.85) + (0.04) \text{ kg} \cdot \text{m}^2]$ $= 39.89 \text{ kg} \cdot \text{m}^2$ <p>Notice that the contribution to the total mass moment of inertia from the shaft is almost negligible. This is because, mass farther away from the axis counts more, in fact a function of the distance squared.</p> <p><i>Step 4.</i> Substitute the total mass moment of inertia (I_{total}) found in step 3, and the given torque (T), in Eq. (9.51).</p> $T = I_{\text{total}} \alpha$ $30 \text{ N} \cdot \text{m} = (39.89 \text{ kg} \cdot \text{m}^2) \alpha$ <p><i>Step 5.</i> Solve for the angular acceleration (α) from step 4.</p> $\alpha = \frac{30 \text{ N} \cdot \text{m}}{39.89 \text{ kg} \cdot \text{m}^2} = 0.75 \frac{\text{N}}{\text{kg} \cdot \text{m}}$ $= 0.75 \frac{\text{kg} \cdot \text{m}/\text{s}^2}{\text{kg} \cdot \text{m}} = 0.75 \frac{\text{rad}}{\text{s}^2}$

The inertial energy (E_{inertial}) of the flywheel and shaft assembly is given by the relationship in Eq. (9.54) as

$$E_{\text{inertial}} = \frac{1}{2} I_{\text{total}} \omega^2 \quad (9.54)$$

If the flywheel and shaft assembly is accelerated from one angular velocity (ω_1) to another angular velocity (ω_2), either speeding up or slowing down, the change in inertial energy levels is the work done on or by the system, denoted (Work)_{1→2}, and is given by the relationship in Eq. (9.55) as

$$\text{Work}_{1 \rightarrow 2} = \frac{1}{2} I_{\text{total}} (\omega_2^2 - \omega_1^2) \quad (9.55)$$

If the system is speeding up, the work done (Work)_{1→2} is positive. Conversely, if the system is slowing down, the work done (Work)_{1→2} is negative.

U.S. Customary	SI/Metric
<p>Example 2. For the flywheel and shaft assembly of Example 1, calculate the work done (Work)_{1→2} to increase its speed, where</p> <p>$\omega_1 = 1,000 \text{ rpm}$ $\omega_2 = 1,500 \text{ rpm}$ $I_{\text{total}} = 29.82 \text{ slug} \cdot \text{ft}^2$ (from Example 1)</p> <p>solution <i>Step 1.</i> Convert the given angular velocities from (rpm) to (rad/s).</p> $\omega_1 = 1,000 \frac{\text{rev}}{\text{min}} \times \frac{2\pi \text{ rad}}{\text{rev}} \times \frac{1 \text{ min}}{60 \text{ s}}$ $= 105 \text{ rad/s}$ $\omega_2 = 1,500 \frac{\text{rev}}{\text{min}} \times \frac{2\pi \text{ rad}}{\text{rev}} \times \frac{1 \text{ min}}{60 \text{ s}}$ $= 157 \text{ rad/s}$ <p><i>Step 2.</i> Substitute the angular velocities from step 1 and the total mass moment of inertia for the system from Example 1 in Eq. (9.55) to give the work done as</p> $\text{Work}_{1 \rightarrow 2} = \frac{1}{2} I_{\text{total}} (\omega_2^2 - \omega_1^2)$ $= \frac{1}{2} (29.82 \text{ slug} \cdot \text{ft}^2)$ $\times \left[\left(157 \frac{\text{rad}}{\text{s}} \right)^2 - \left(105 \frac{\text{rad}}{\text{s}} \right)^2 \right]$ $= \frac{1}{2} (29.82 \text{ slug} \cdot \text{ft}^2)$ $\times \left[13,624 \frac{\text{rad}^2}{\text{s}^2} \right]$ $= 2.03 \times 10^5 \frac{\text{slug} \cdot \text{ft}^2}{\text{s}^2}$ $= 2.03 \times 10^5 \text{ ft} \cdot \text{lb}$ $= 203 \text{ ft} \cdot \text{kip}$ <p>As the work done is positive, work was done on the system.</p>	<p>Example 2. For the flywheel and shaft assembly of Example 1, calculate the work done (Work)_{1→2} to increase its speed, where</p> <p>$\omega_1 = 1,000 \text{ rpm}$ $\omega_2 = 1,500 \text{ rpm}$ $I_{\text{total}} = 39.89 \text{ kg} \cdot \text{m}^2$ (from Example 1)</p> <p>solution <i>Step 1.</i> Convert the given angular velocities from (rpm) to (rad/s)</p> $\omega_1 = 1,000 \frac{\text{rev}}{\text{min}} \times \frac{2\pi \text{ rad}}{\text{rev}} \times \frac{1 \text{ min}}{60 \text{ s}}$ $= 105 \text{ rad/s}$ $\omega_2 = 1,500 \frac{\text{rev}}{\text{min}} \times \frac{2\pi \text{ rad}}{\text{rev}} \times \frac{1 \text{ min}}{60 \text{ s}}$ $= 157 \text{ rad/s}$ <p><i>Step 2.</i> Substitute the angular velocities from step 1 and the total mass moment of inertia for the system from Example 1 in Eq. (9.55) to give the work done as</p> $\text{Work}_{1 \rightarrow 2} = \frac{1}{2} I_{\text{total}} (\omega_2^2 - \omega_1^2)$ $= \frac{1}{2} (39.89 \text{ kg} \cdot \text{m}^2)$ $\times \left[\left(157 \frac{\text{rad}}{\text{s}} \right)^2 - \left(105 \frac{\text{rad}}{\text{s}} \right)^2 \right]$ $= \frac{1}{2} (39.89 \text{ kg} \cdot \text{m}^2)$ $\times \left[13,624 \frac{\text{rad}^2}{\text{s}^2} \right]$ $= 2.72 \times 10^5 \frac{\text{kg} \cdot \text{m}^2}{\text{s}^2}$ $= 2.72 \times 10^5 \text{ N} \cdot \text{m}$ $= 272 \text{ kN} \cdot \text{m}$ <p>As the work done is positive, work was done on the system.</p>

The torque (T) flywheels are designed to smooth out and vary in two primary ways:

1. Varies with the rotation angle (θ)—internal combustion engine
2. Varies with the angular velocity (ω)—electric motor driven punch press

The design of flywheels for each of these variations will now be presented.

9.3.2 Internal Combustion Engine Flywheels

The torque (T) delivered by an internal combustion engine is a function of the rotation angle (θ). In fact, for a four-stroke engine, power is delivered during only one of the four 180° cycles. For the other three cycles, the inertia and thermodynamic processes of the system are slowing the engine down. If the engine has only one cylinder, the variation in torque, and therefore, the power, is greater than if the engine has multiple cylinders, say six or eight, each delivering power at different rotation angles. However, the design of the flywheel for this type of engine, whatever the number of cylinders, is the same.

A graph of the torque (T) versus rotation angle (θ) for one cycle of a four-stroke, single-cylinder, internal combustion engine is shown in Fig. 9.9.

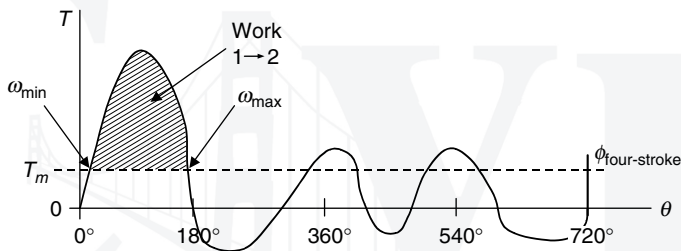

FIGURE 9.9 Torque as a function of rotation angle (θ).

There are several important quantities to note in Fig. 9.9. First, the mean torque (T_m) is the average torque over the total angle of rotation, balancing the areas under the curve above and below the zero torque line. For a four-stroke engine the total angle of rotation (ϕ) is 2 revolutions, or 720° , or 4π rad, whereas for a two-stroke engine the total angle of rotation (ϕ) is 1 revolution, or 360° , or 2π rad.

Second, the minimum angular velocity (ω_{\min}) occurs at the start of the power cycle and the maximum angular velocity (ω_{\max}) occurs at the end of the power cycle. The engine slows down from the angle of rotation for maximum angular velocity to the angle of rotation that starts the next power cycle. Also, whenever the torque curve passes through the mean torque line, the system has zero angular acceleration, which means it has the mean angular velocity (ω_m).

Third, the work done on the system to increase its speed from the minimum angular velocity to the maximum angular velocity is the area of the shaded region shown. It is determined once the mean torque (T_m) has been found, usually graphically, from the relationship in Eq. (9.56) as

$$\text{Work}_{1 \rightarrow 2} = T_m \phi \quad (9.56)$$

where (ϕ) is the total angle of rotation for one cycle of the engine.

The work done can be related to the angular velocities and the inertia of the system by modifying Eq. (9.55) as

$$\text{Work}_{1 \rightarrow 2} = \frac{1}{2} I_{\text{sys}} (\omega_{\text{max}}^2 - \omega_{\text{min}}^2) \quad (9.57)$$

The difference in the squares of the angular velocities in Eq. (9.57) can be expressed algebraically as the product of two terms as shown in Eq. (9.58).

$$\begin{aligned} \text{Work}_{1 \rightarrow 2} &= \frac{1}{2} I_{\text{sys}} (\omega_{\text{max}}^2 - \omega_{\text{min}}^2) \\ &= \frac{1}{2} I_{\text{sys}} (\omega_{\text{max}} + \omega_{\text{min}}) (\omega_{\text{max}} - \omega_{\text{min}}) \\ &= I_{\text{sys}} \left(\frac{\omega_{\text{max}} + \omega_{\text{min}}}{2} \right) (\omega_{\text{max}} - \omega_{\text{min}}) \\ &= I_{\text{sys}} \omega_o (\omega_{\text{max}} - \omega_{\text{min}}) \end{aligned} \quad (9.58)$$

where (ω_o) is not the mean or average angular velocity (ω_m) as the torque curve is not symmetrical about the horizontal axis.

If a coefficient of speed fluctuation (C_f) is defined as

$$C_f = \frac{\omega_{\text{max}} - \omega_{\text{min}}}{\omega_m} \quad (9.59)$$

then the expression for the work done (Work)_{1→2} given in Eq. (9.58) becomes

$$\begin{aligned} \text{Work}_{1 \rightarrow 2} &= I_{\text{sys}} \omega_o (\omega_{\text{max}} - \omega_{\text{min}}) \\ &= I_{\text{sys}} \omega_o (C_f \omega_m) \end{aligned} \quad (9.60)$$

Most designs call for a small coefficient of fluctuation (C_f), which means the angular velocity (ω_o) will be approximately equal to the mean angular velocity (ω_m). Therefore, Eq. (9.60) becomes

$$\begin{aligned} \text{Work}_{1 \rightarrow 2} &= I_{\text{sys}} \omega_o (C_f \omega_m) \\ &= I_{\text{sys}} C_f \omega_m^2 \end{aligned} \quad (9.61)$$

Solving for the mass moment of inertia of the system (I_{sys}) in Eq. (9.61), and substituting for the work done in terms of the mean torque (T_m) and the total angle of rotation (ϕ) from Eq. (9.56), gives

$$I_{\text{sys}} = \frac{\text{Work}_{1 \rightarrow 2}}{C_f \omega_m^2} = \frac{T_m \phi}{C_f \omega_m^2} \quad (9.62)$$

Note that while it is desired to keep the coefficient of fluctuation (C_f) as small as possible, it would take an infinite mass moment of inertia in the system to make it zero. Therefore, the system will always have some variation in angular velocity.

The mean torque (T_m) and mean angular velocity (ω_m) are related to the power (P) delivered by the engine. The power (P), measured experimentally, is usually given at a

specific angular velocity in revolutions per minute (rpm). The relationship between power, mean torque, and mean angular velocity is given in Eq. (9.63) as

$$P = T_m \omega_m \quad (9.63)$$

Solving for the mean torque (T_m) gives

$$T_m = \frac{P}{\omega_m} \quad (9.64)$$

Once the mean torque (T_m) is found from Eq. (9.64), rather than graphically, over a total angle of rotation (ϕ) for one cycle, and using the given mean angular velocity (ω_m) and the desired coefficient of fluctuation (C_f), the required mass moment of the system (I_{sys}) can be determined from Eq. (9.62).

Consider the following example where a four-stroke, single cylinder, internal combustion engine is to deliver continuously a specified amount of power at a specified angular speed to a centrifugal pump, and for a given coefficient of fluctuation.

(Note, the coefficient of fluctuation (C_f) will usually be given as a percentage, as it is the ratio of the difference between the maximum and minimum angular velocities and the mean angular velocity.)

U.S. Customary	SI/Metric
<p>Example 3. For the engine and pump arrangement presented above, determine the required mass moment of inertia for the system, where</p> <p>$P = 10 \text{ HP}$ $\omega_m = 1,800 \text{ rpm}$ $\phi = 4\pi \text{ rad (four-stroke engine)}$ $C_f = 5\% = 0.05$</p> <p>solution <i>Step 1.</i> Convert the given power (P) from horsepower (HP) to (ft · lb/s).</p> $P = 10 \text{ HP} \times \frac{550 \frac{\text{ft} \cdot \text{lb}}{\text{s}}}{\text{HP}} = 5,500 \frac{\text{ft} \cdot \text{lb}}{\text{s}}$ <p><i>Step 2.</i> Convert the given mean angular velocity (ω_m) from (rpm) to (rad/s).</p> $\omega_m = 1,800 \frac{\text{rev}}{\text{min}} \times \frac{2\pi \text{ rad}}{\text{rev}} \times \frac{1 \text{ min}}{60 \text{ s}}$ $= 188.5 \text{ rad/s}$ <p><i>Step 3.</i> Substitute the power (P) from step 1 and the angular velocity (ω_m) from step 2 in Eq. (9.64) to give the mean torque (T_m) as</p> $T_m = \frac{P}{\omega_m} = \frac{5,500 \frac{\text{ft} \cdot \text{lb}}{\text{s}}}{188.5 \frac{\text{rad}}{\text{s}}} = 29.2 \text{ ft} \cdot \text{lb}$	<p>Example 3. For the engine and pump arrangement presented above, determine the required mass moment of inertia for the system, where</p> <p>$P = 8.5 \text{ kW}$ $\omega_m = 1,800 \text{ rpm}$ $\phi = 4\pi \text{ rad (four-stroke engine)}$ $C_f = 5\% = 0.05$</p> <p>solution <i>Step 1.</i> Convert the given power (P) from kilowatts (kW) to (N · m/s).</p> $P = 8.5 \text{ kW} \times \frac{1,000 \frac{\text{N} \cdot \text{m}}{\text{s}}}{\text{kW}} = 8,500 \frac{\text{N} \cdot \text{m}}{\text{s}}$ <p><i>Step 2.</i> Convert the given mean angular velocity (ω_m) from (rpm) to (rad/s).</p> $\omega_m = 1,800 \frac{\text{rev}}{\text{min}} \times \frac{2\pi \text{ rad}}{\text{rev}} \times \frac{1 \text{ min}}{60 \text{ s}}$ $= 188.5 \text{ rad/s}$ <p><i>Step 3.</i> Substitute the power (P) from step 1 and the angular velocity (ω_m) from step 2 in Eq. (9.64) to give the mean torque (T_m) as</p> $T_m = \frac{P}{\omega_m} = \frac{8,500 \frac{\text{N} \cdot \text{m}}{\text{s}}}{188.5 \frac{\text{rad}}{\text{s}}} = 45.1 \text{ N} \cdot \text{m}$

U.S. Customary	SI/Metric
<p><i>Step 4.</i> Substitute the mean torque (T_m) from step 3, the angular velocity (ω_m) from step 2, and the given angle of rotation (ϕ) for one cycle and the coefficient of fluctuation (C_f) in Eq. (9.62) to give the required mass moment of inertia for the system (I_{sys}) as</p> $I_{sys} = \frac{T_m \phi}{C_f \omega_m^2} = \frac{(29.2 \text{ ft} \cdot \text{lb})(4\pi \text{ rad})}{(0.05) \left(188.5 \frac{\text{rad}}{\text{s}}\right)^2}$ $= \frac{367 \text{ ft} \cdot \text{lb}}{1,777 \frac{1}{\text{s}^2}} = 0.21 \text{ (ft} \cdot \text{lb} \cdot \text{s}^2)$ $= 0.21 \left(\text{ft} \cdot \frac{\text{slug} \cdot \text{ft}}{\text{s}^2} \cdot \text{s}^2\right)$ $= 0.21 \text{ slug} \cdot \text{ft}^2$ <p>If the engine had been a two-stroke instead of a four-stroke, then the amount of inertia needed would be half the value calculated in step 4.</p>	<p><i>Step 4.</i> Substitute the mean torque (T_m) from step 3, the angular velocity (ω_m) from step 2, and the given angle of rotation (ϕ) for one cycle and the coefficient of fluctuation (C_f) in Eq. (9.62) to give the required mass moment of inertia for the system (I_{sys}) as</p> $I_{sys} = \frac{T_m \phi}{C_f \omega_m^2} = \frac{(45.1 \text{ N} \cdot \text{m})(4\pi \text{ rad})}{(0.05) \left(188.5 \frac{\text{rad}}{\text{s}}\right)^2}$ $= \frac{567 \text{ N} \cdot \text{m}}{1,777 \frac{1}{\text{s}^2}} = 0.32 \text{ (N} \cdot \text{m} \cdot \text{s}^2)$ $= 0.32 \left(\frac{\text{kg} \cdot \text{m}}{\text{s}^2} \cdot \text{m} \cdot \text{s}^2\right)$ $= 0.32 \text{ kg} \cdot \text{m}^2$ <p>If the engine had been two-stroke instead of four-stroke, then the amount of inertia needed would be half the value calculated in step 4.</p>

9.3.3 Punch Press Flywheels

The torque (T) delivered by an electric motor is a function of the angular velocity (ω). A graph of the torque (T) versus angular velocity (ω) for a typical induction electric motor is shown in Fig. 9.10.

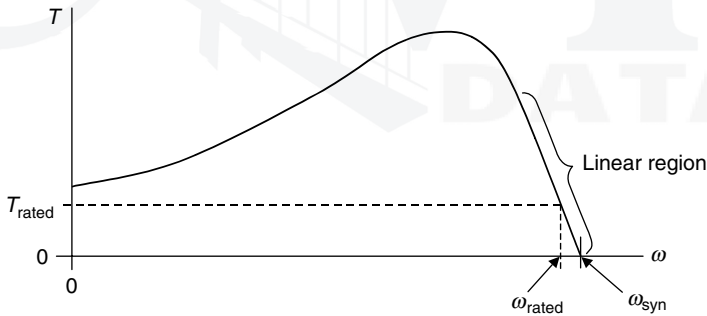

FIGURE 9.10 Torque as a function of angular velocity (ω).

There are several important features to note in Fig. 9.10. First, the synchronous angular velocity (ω_{syn}) is for a zero, or no load, torque. This angular velocity would be given (in rpm) on the identification plate on the motor.

Second, the motor would have a rated power (P_{rated}) delivered at a rated angular velocity (ω_{rated}), again both given on the identification plate of the motor. By analogy with Eq. (9.64), the rated torque (T_{rated}) can be found from the following relationship:

$$T_{rated} = \frac{P_{rated}}{\omega_{rated}} \tag{9.65}$$

Third, this type of motor works best, mechanically and economically, in the linear region of the curve noted in the figure. The information found on the identification plate can be used to determine an equation of this straight line portion of the curve. Leaving out the algebra steps, the equation of this straight line can be found to be of the form

$$T = T_{\text{rated}} \frac{\omega_{\text{syn}} - \omega}{\omega_{\text{syn}} - \omega_{\text{rated}}} \tag{9.66}$$

Therefore, for a torque (T) there is corresponding angular velocity (ω), and vice versa. However, usually the torque (T) will be known from the requirements of the system to which the electric motor is connected. A typical application is a punch press.

Punch Press. Without getting into too much detail, basically a punch press operates cyclically to stamp out parts, or punch holes, or shapes, or both in parts. The inertial energy of the system, most of which is contained in an appropriately designed flywheel, does the actual punching. The electric motor that is connected to the punch press is then used to return the flywheel to its initial punching speed before the next punching cycle begins. An electric motor is chosen because of the properties already presented.

The cyclic punching process is shown in Fig. 9.11,

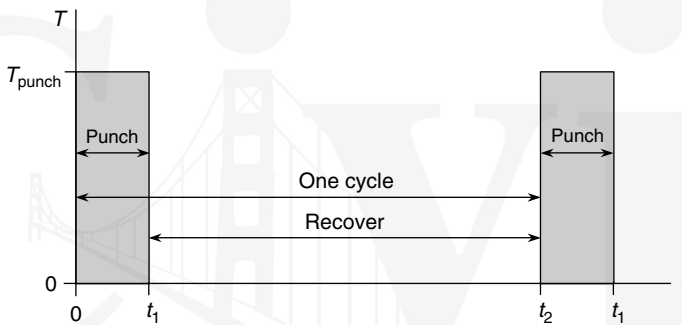

FIGURE 9.11 Punch press cycle—torque versus time.

where the time (t_1) is length of the actual punching process and time (t_2) is the start of the next cycle. During the time interval ($t_2 - t_1$), the system must recover.

From the electric motor's perspective, the motor has an angular velocity (ω_1) at time (t_1), the end of the punching process, and must increase its speed to an angular velocity (ω_2) at time (t_2), the start of the punching process. There are corresponding torques (T_1) and (T_2) for these two angular velocities, as shown on Fig. 9.12.

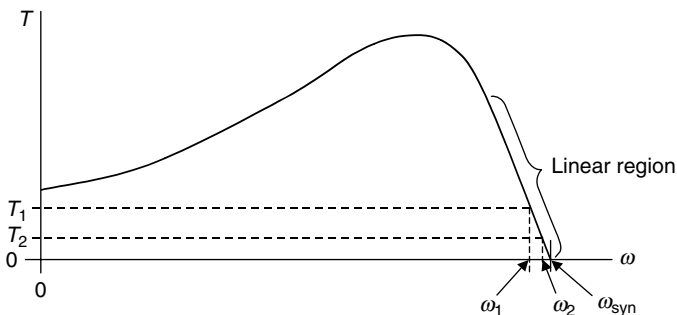

FIGURE 9.12 Torques and angular velocities for punch press.

The torque (T_1) and angular velocity (ω_1) are usually taken to be the rated torque (T_{rated}) and rated angular velocity (ω_{rated}). Therefore, the torque (T_2) and angular velocity (ω_2) must be found using information associated with the punching process and the available time for recovery.

Again, the electric motor does not do the actual punching; the inertial energy in the system, mostly in the flywheel, does the punching. The system loses energy, and therefore speed, during the punching process and must return to its design speed before the next cycle begins. As might be expected, the inertia in the system must be just the right amount for the punch press system to work properly.

During the punching process, the torque required (T_{punch}) draws energy from the system and slows it down to an angular velocity (ω_2). Leaving out the details, the corresponding torque (T_2) can be found from Eq (9.67) as

$$\frac{T_2}{T_1} = \left(\frac{T_{\text{punch}} - T_1}{T_{\text{punch}} - T_2} \right)^\tau \quad (9.67)$$

where the exponent (τ) is the ratio of the recovery time to the punching time, meaning

$$\tau = \frac{t_2 - t_1}{t_1} \quad (9.68)$$

Unfortunately, the torque (T_2) must be determined from Eq. (9.67) by trial-and-error; however, this is not a burden. Once the punching torque (T_{punch}) is known, the rated torque (T_1) is found from Eq. (9.65) where the rated power (P_{rated}) and the rated angular velocity (ω_{rated}) are obtained from the motor identification plate.

During recovery, the rated torque (T_1) adds energy to the system as it increases its angular velocity from (ω_1) to (ω_2) in time for the next punching interval. The system resists this increase in speed through its mass moment of inertia (I_{sys}). Leaving out the details, the mass moment of inertia of the system (I_{sys}) can be found from Eq (9.69) as

$$I_{\text{sys}} = \frac{a (t_2 - t_1)}{\ln \left(\frac{T_2}{T_1} \right)} \quad (9.69)$$

where (a) is the slope of the motor torque curve in the linear region, given in Eq. (9.70) as

$$a = \frac{T_1}{\omega_1 - \omega_{\text{syn}}} \quad (9.70)$$

The slope (a) will be negative; however, the denominator of Eq. (9.69) will also be negative, so the mass moment of inertia of the system (I_{sys}) will come out positive.

For electric motors, a coefficient of fluctuation (C_f) can be defined as

$$C_f = \frac{\omega_{\text{max}} - \omega_{\text{min}}}{\omega_{\text{max}} + \omega_{\text{min}}} = \frac{\omega_{\text{max}} - \omega_{\text{min}}}{\omega_m} \quad (9.71)$$

where the maximum angular velocity is (ω_2) and the minimum is (ω_1). Also, as the coefficient of fluctuation is usually very small, the mean angular velocity (ω_m) can be assumed to be (ω_1). Therefore, the coefficient of fluctuation (C_f) becomes

$$C_f = \frac{\omega_2 - \omega_1}{\omega_1} \quad (9.72)$$

By analogy with the discussion for internal combustion engines where the torque varies with the angle of rotation, the change in the inertial energy levels of the punch press system is equal to the work done on or by the system. Therefore, Eq. (9.57) is applicable here where the torque varies with angular velocity. Expanding the difference in angular velocities in Eq. (9.57) as it was done in Eq. (9.58), the work done becomes

$$\begin{aligned} \text{Work}_{1 \rightarrow 2} &= \frac{1}{2} I_{\text{sys}} (\omega_{\text{max}}^2 - \omega_{\text{min}}^2) = \frac{1}{2} I_{\text{sys}} (\omega_2^2 - \omega_1^2) \\ &= \frac{1}{2} I_{\text{sys}} (\omega_2 + \omega_1) (\omega_2 - \omega_1) = I_{\text{sys}} \left(\frac{\omega_2 + \omega_1}{2} \right) (\omega_2 - \omega_1) \quad (9.73) \\ &= I_{\text{sys}} \omega_m (\omega_2 - \omega_1) = I_{\text{sys}} \omega_1 (C_f \omega_1) \\ &= I_{\text{sys}} C_f \omega_1^2 \end{aligned}$$

Solving for the mass moment of inertia of the system (I_{sys}) in Eq. (9.73) gives

$$I_{\text{sys}} = \frac{\text{Work}_{1 \rightarrow 2}}{C_f \omega_1^2} \quad (9.74)$$

which is very similar to Eq. (9.62) for internal combustion engines. However, the mass moment of inertia of a punch press system (I_{sys}) is actually determined using Eq. (9.69), once the torque (T_2) has been found by trial and error using Eq. (9.67).

U.S. Customary	SI/Metric
<p>Example 4. A punch press requires a certain punching torque during only 4 percent of the punching cycle, which is (1 s). Determine the required mass moment of inertia of the system (I_{sys}) and the coefficient of fluctuation (C_f), where</p> <p>$T_{\text{punch}} = 150 \text{ ft} \cdot \text{lb}$ $t_2 = 1 \text{ s}$ $P_{\text{rated}} = 5 \text{ hp}$ $\omega_{\text{rated}} = 1,725 \text{ rpm}$ $\omega_{\text{syn}} = 1,800 \text{ rpm}$</p> <p>solution</p> <p><i>Step 1.</i> Convert the rated power (P_{rated}) from horsepower (HP) to (ft · lb/s).</p> $\begin{aligned} P_{\text{rated}} &= 5 \text{ HP} \times \frac{550 \frac{\text{ft} \cdot \text{lb}}{\text{s}}}{\text{HP}} \\ &= 2,750 \frac{\text{ft} \cdot \text{lb}}{\text{s}} \end{aligned}$ <p><i>Step 2.</i> Convert the rated angular velocity (ω_{rated}) from (rpm) to (rad/s).</p> $\begin{aligned} \omega_{\text{rated}} &= 1,725 \frac{\text{rev}}{\text{min}} \times \frac{2\pi \text{ rad}}{\text{rev}} \times \frac{1 \text{ min}}{60 \text{ s}} \\ &= 180.6 \text{ rad/s} \end{aligned}$	<p>Example 4. A punch press requires a certain punching torque during only 4 percent of the punching cycle, which is (1 s). Determine the required mass moment of inertia of the system (I_{sys}) and the coefficient of fluctuation (C_f), where</p> <p>$T_{\text{punch}} = 225 \text{ N} \cdot \text{m}$ $t_2 = 1 \text{ s}$ $P_{\text{rated}} = 4 \text{ kW}$ $\omega_{\text{rated}} = 1,725 \text{ rpm}$ $\omega_{\text{syn}} = 1,800 \text{ rpm}$</p> <p>solution</p> <p><i>Step 1.</i> Convert the rated power (P_{rated}) from kilowatts (kW) to (N · m/s).</p> $\begin{aligned} P_{\text{rated}} &= 4 \text{ kW} \times \frac{1,000 \frac{\text{N} \cdot \text{m}}{\text{s}}}{\text{kW}} \\ &= 4,000 \frac{\text{N} \cdot \text{m}}{\text{s}} \end{aligned}$ <p><i>Step 2.</i> Convert the rated angular velocity (ω_{rated}) from (rpm) to (rad/s).</p> $\begin{aligned} \omega_{\text{rated}} &= 1,725 \frac{\text{rev}}{\text{min}} \times \frac{2\pi \text{ rad}}{\text{rev}} \times \frac{1 \text{ min}}{60 \text{ s}} \\ &= 180.6 \text{ rad/s} \end{aligned}$

U.S. Customary	SI/Metric
<p><i>Step 3.</i> Substitute the rated power (P_{rated}) from step 1 and the rated angular velocity (ω_{rated}) from step 2 in Eq. (9.65) to give the rated torque (T_{rated}) as</p> $T_{\text{rated}} = \frac{P_{\text{rated}}}{\omega_{\text{rated}}} = \frac{2,750 \frac{\text{ft} \cdot \text{lb}}{\text{s}}}{180.6 \frac{\text{rad}}{\text{s}}}$ $= 15.2 \text{ ft} \cdot \text{lb}$	<p><i>Step 3.</i> Substitute the rated power (P_{rated}) from step 1 and the rated angular velocity (ω_{rated}) from step 2 in Eq. (9.65) to give the rated torque (T_{rated}) as</p> $T_{\text{rated}} = \frac{P_{\text{rated}}}{\omega_{\text{rated}}} = \frac{4,000 \frac{\text{N} \cdot \text{m}}{\text{s}}}{180.6 \frac{\text{rad}}{\text{s}}}$ $= 22.1 \text{ N} \cdot \text{m}$
<p><i>Step 4.</i> For a punch press system, the rated torque (T_{rated}) is the torque (T_1) and the rated angular velocity (ω_{rated}) is the angular velocity (ω_1). Therefore,</p> $T_1 = 15.2 \text{ ft} \cdot \text{lb}$ <p style="text-align: center;">and</p> $\omega_1 = 1,725 \text{ rpm}$	<p><i>Step 4.</i> For a punch press system, the rated torque (T_{rated}) is the torque (T_1) and the rated angular velocity (ω_{rated}) is the angular velocity (ω_1). Therefore,</p> $T_1 = 22.1 \text{ N} \cdot \text{m}$ <p style="text-align: center;">and</p> $\omega_1 = 1,725 \text{ rpm}$
<p><i>Step 5.</i> If the punching interval is 4 percent of the total cycle time, then</p> $t_1 = 0.04 t_2$	<p><i>Step 5.</i> If the punching interval is 4 percent of the total cycle time, then</p> $t_1 = 0.04 t_2$
<p><i>Step 6.</i> Using the relationship in step 5, calculate the recovery time to punching time ratio (τ) using Eq. (9.68).</p> $\tau = \frac{t_2 - t_1}{t_1} = \frac{t_2 - 0.4 t_2}{0.04 t_2} = \frac{1 - 0.04}{0.04} = \frac{0.96}{0.04}$ $= 24$	<p><i>Step 6.</i> Using the relationship in step 5, calculate the recovery time to punching time ratio (τ) using Eq. (9.68).</p> $\tau = \frac{t_2 - t_1}{t_1} = \frac{t_2 - 0.4 t_2}{0.04 t_2} = \frac{1 - 0.04}{0.04} = \frac{0.96}{0.04}$ $= 24$
<p><i>Step 7.</i> Substitute the given punching torque (T_{punch}), the torque (T_1) from step 4, and the exponent (τ) in Eq. (9.67).</p> $\frac{T_2}{T_1} = \left(\frac{T_{\text{punch}} - T_1}{T_{\text{punch}} - T_2} \right)^\tau$ $\frac{T_2}{15.2} = \left(\frac{150 - 15.2}{150 - T_2} \right)^{24}$ $T_2 = 15.2 \left(\frac{134.8}{150 - T_2} \right)^{24}$	<p><i>Step 7.</i> Substitute the given punching torque (T_{punch}), the torque (T_1) from step 4, and the exponent (τ) in Eq. (9.67).</p> $\frac{T_2}{T_1} = \left(\frac{T_{\text{punch}} - T_1}{T_{\text{punch}} - T_2} \right)^\tau$ $\frac{T_2}{22.1} = \left(\frac{225 - 22.1}{225 - T_2} \right)^{24}$ $T_2 = 22.1 \left(\frac{202.9}{225 - T_2} \right)^{24}$
<p><i>Step 8.</i> Solve for the torque (T_2) in the expression from step 7 by trial and error. Try a first guess of 5 ft · lb.</p> $5 \stackrel{?}{=} 15.2 \left(\frac{134.8}{150 - 5} \right)^{24}$ $5 \stackrel{?}{=} 15.2 (0.930)^{24}$ $5 \stackrel{?}{=} 15.2 (0.174) = 2.64$ <p style="text-align: center;">(too high)</p>	<p><i>Step 8.</i> Solve for the torque (T_2) in the expression from step 7 by trial and error. Try a first guess of 9 N · m.</p> $9 \stackrel{?}{=} 22.1 \left(\frac{202.9}{225 - 9} \right)^{24}$ $9 \stackrel{?}{=} 22.1 (0.939)^{24}$ $9 \stackrel{?}{=} 22.1 (0.223) = 4.92$ <p style="text-align: center;">(too high)</p>

U.S. Customary	SI/Metric
<p>Try 2.5 ft · lb</p> $2.5 \stackrel{?}{=} 15.2 \left(\frac{134.8}{150 - 2.5} \right)^{24}$ $2.5 \stackrel{?}{=} 15.2 (0.914)^{24}$ $2.5 \stackrel{?}{=} 15.2 (0.115) = 1.75$ <p>(too high)</p> <p>Try 1.5 ft · lb</p> $1.5 \stackrel{?}{=} 15.2 \left(\frac{134.8}{150 - 1.5} \right)^{24}$ $1.5 \stackrel{?}{=} 15.2 (0.908)^{24}$ $1.5 \stackrel{?}{=} 15.2 (0.098) = 1.49$ <p>(close enough)</p> <p>Therefore, the torque (T_2) is</p> $T_2 = 1.5 \text{ ft} \cdot \text{lb}$ <p><i>Step 9.</i> Substitute the torque (T_2) found in step 8, the rated torque ($T_{\text{rated}} = (T_1)$), the rated angular velocity ($\omega_{\text{rated}} = (\omega_1)$), and the given synchronous speed (ω_{syn}) in Eq. (9.66) to find the corresponding angular velocity (ω_2).</p> $T_2 = T_1 \frac{\omega_{\text{syn}} - \omega_2}{\omega_{\text{syn}} - \omega_1}$ $1.5 \text{ ft} \cdot \text{lb} = (15.2 \text{ ft} \cdot \text{lb}) \times \frac{(1,800 \text{ rpm}) - \omega_2}{(1,800 - 1,725) \text{ rpm}}$ $\frac{1.5 \text{ ft} \cdot \text{lb}}{15.2 \text{ ft} \cdot \text{lb}} = \frac{(1,800 \text{ rpm}) - \omega_2}{75 \text{ rpm}}$ $(0.099)(75 \text{ rpm}) = (1,800 \text{ rpm}) - \omega_2$ $7.4 \text{ rpm} = (1,800 \text{ rpm}) - \omega_2$ $\omega_2 = 1,793 \text{ rpm}$ <p><i>Step 10.</i> Substitute the angular velocity (ω_2) found in step 9 and the angular velocity (ω_1) in Eq. (9.72) to find the coefficient of fluctuation (C_f) as</p> $C_f = \frac{\omega_2 - \omega_1}{\omega_1} = \frac{(1,793 - 1,725) \text{ rpm}}{1,725 \text{ rpm}}$ $= \frac{68 \text{ rpm}}{1,725 \text{ rpm}} = 0.039$	<p>Try 4.5 N · m</p> $4.5 \stackrel{?}{=} 22.1 \left(\frac{202.9}{225 - 4.5} \right)^{24}$ $4.5 \stackrel{?}{=} 22.1 (0.920)^{24}$ $4.5 \stackrel{?}{=} 22.1 (0.136) = 3.00$ <p>(too high)</p> <p>Try 2.25 N · m</p> $2.25 \stackrel{?}{=} 22.1 \left(\frac{202.9}{225 - 2.25} \right)^{24}$ $2.25 \stackrel{?}{=} 22.1 (0.911)^{24}$ $2.25 \stackrel{?}{=} 22.1 (0.106) = 2.35$ <p>(close enough)</p> <p>Therefore, the torque (T_2) is</p> $T_2 = 2.25 \text{ N} \cdot \text{m}$ <p><i>Step 9.</i> Substitute the torque (T_2) found in step 8, the rated torque ($T_{\text{rated}} = (T_1)$), the rated angular velocity ($\omega_{\text{rated}} = (\omega_1)$), and the given synchronous speed (ω_{syn}) in Eq. (9.66) to find the corresponding angular velocity (ω_2).</p> $T_2 = T_1 \frac{\omega_{\text{syn}} - \omega_2}{\omega_{\text{syn}} - \omega_1}$ $2.25 \text{ N} \cdot \text{m} = (22.1 \text{ N} \cdot \text{m}) \times \frac{(1,800 \text{ rpm}) - \omega_2}{(1,800 - 1,725) \text{ rpm}}$ $\frac{2.25 \text{ N} \cdot \text{m}}{22.1 \text{ N} \cdot \text{m}} = \frac{(1,800 \text{ rpm}) - \omega_2}{75 \text{ rpm}}$ $(0.102)(75 \text{ rpm}) = (1,800 \text{ rpm}) - \omega_2$ $7.6 \text{ rpm} = (1,800 \text{ rpm}) - \omega_2$ $\omega_2 = 1,792 \text{ rpm}$ <p><i>Step 10.</i> Substitute the angular velocity (ω_2) found in step 9 and the angular velocity (ω_1) in Eq. (9.72) to find the coefficient of fluctuation (C_f) as</p> $C_f = \frac{\omega_2 - \omega_1}{\omega_1} = \frac{(1,792 - 1,725) \text{ rpm}}{1,725 \text{ rpm}}$ $= \frac{67 \text{ rpm}}{1,725 \text{ rpm}} = 0.039$

U.S. Customary	SI/Metric
<p><i>Step 11.</i> Calculate the slope (a) of the motor curve in the linear region using Eq. (9.70) as</p> $a = \frac{T_1}{\omega_1 - \omega_{\text{syn}}} = \frac{15.2 \text{ ft} \cdot \text{lb}}{(1,725 - 1,800) \text{ rpm}}$ $= \frac{15.2 \text{ ft} \cdot \text{lb}}{-75 \text{ rpm}} = -0.203 \frac{\text{ft} \cdot \text{lb}}{\text{rpm}}$ <p><i>Step 12.</i> Using the slope (a) found in step 11, the times (t_1) and (t_2), and the torques (T_1) and (T_2) in Eq. (9.69), calculate the mass moment of inertia of the system (I_{sys}) as</p> $I_{\text{sys}} = \frac{a (t_2 - t_1)}{\ln \left(\frac{T_2}{T_1} \right)}$ $= \frac{\left(-0.203 \frac{\text{ft} \cdot \text{lb}}{\text{rpm}} \right) (1 - 0.04) \text{ s}}{\ln (1.5 \text{ ft} \cdot \text{lb} / 15.2 \text{ ft} \cdot \text{lb})}$ $= \frac{(-0.203)(0.96) \frac{\text{ft} \cdot \text{lb} \cdot \text{s}}{\text{rpm}}}{\ln (0.099)}$ $= \frac{-0.195 \text{ ft} \cdot \text{lb} \cdot \text{s}}{-2.316 \text{ rpm}}$ $= 0.084 \frac{\text{ft} \cdot \text{lb} \cdot \text{s}}{\text{rpm}} \times \frac{1 \text{ rpm}}{\frac{2\pi}{60} \frac{\text{rad}}{\text{s}}}$ $= (0.084) \frac{60}{2\pi} (\text{ft} \cdot \text{lb} \cdot \text{s}^2)$ $= 0.8 \left(\text{ft} \cdot \frac{\text{slug} \cdot \text{ft}}{\text{s}^2} \cdot \text{s}^2 \right)$ $= 0.8 \text{ slug} \cdot \text{ft}^2$ <p>Remember that the mass moment of inertia (I_{sys}) found in step 12 is for the entire system that includes the flywheel.</p>	<p><i>Step 11.</i> Calculate the slope (a) of the motor curve in the linear region using Eq. (9.70) as</p> $a = \frac{T_1}{\omega_1 - \omega_{\text{syn}}} = \frac{22.1 \text{ N} \cdot \text{m}}{(1,725 - 1,800) \text{ rpm}}$ $= \frac{22.1 \text{ N} \cdot \text{m}}{-75 \text{ rpm}} = -0.295 \frac{\text{N} \cdot \text{m}}{\text{rpm}}$ <p><i>Step 12.</i> Using the slope (a) found in step 11, the times (t_1) and (t_2), and the torques (T_1) and (T_2) in Eq. (9.69), calculate the mass moment of inertia of the system (I_{sys}) as</p> $I_{\text{sys}} = \frac{a (t_2 - t_1)}{\ln \left(\frac{T_2}{T_1} \right)}$ $= \frac{\left(-0.295 \frac{\text{N} \cdot \text{m}}{\text{rpm}} \right) (1 - 0.04) \text{ s}}{\ln (2.25 \text{ N} \cdot \text{m} / 22.1 \text{ N} \cdot \text{m})}$ $= \frac{(-0.295)(0.96) \frac{\text{N} \cdot \text{m} \cdot \text{s}}{\text{rpm}}}{\ln (0.102)}$ $= \frac{-0.283 \text{ N} \cdot \text{m} \cdot \text{s}}{-2.285 \text{ rpm}}$ $= 0.124 \frac{\text{N} \cdot \text{m} \cdot \text{s}}{\text{rpm}} \times \frac{1 \text{ rpm}}{\frac{2\pi}{60} \frac{\text{rad}}{\text{s}}}$ $= (0.124) \frac{60}{2\pi} (\text{N} \cdot \text{m} \cdot \text{s}^2)$ $= 1.2 \left(\frac{\text{kg} \cdot \text{m}}{\text{s}^2} \cdot \text{m} \cdot \text{s}^2 \right)$ $= 1.2 \text{ kg} \cdot \text{m}^2$ <p>Remember that the mass moment of inertia (I_{sys}) found in step 12 is for the entire system that includes the flywheel.</p>

9.3.4 Composite Flywheels

The flywheel shown in Fig. 9.8 is the simplest of designs, that is, a solid circular disk. This is probably the easiest and the most economical design to produce; however, it is not the most efficient use of material, and therefore, weight. This has been known for quite some time, as the design of more efficient flywheels became almost an art in the nineteenth century, carrying on to the twentieth century and now to the new millennium.

Better designs are achieved by moving material from near the axis of rotation and placing it as far as practical from the axis. (Remember, mass moment of inertia is a measure of the distribution of mass, and mass farther away from the axis counts more than the same amount of mass near the axis.) The traditional theme of more efficient flywheels is shown in Fig. 9.13,

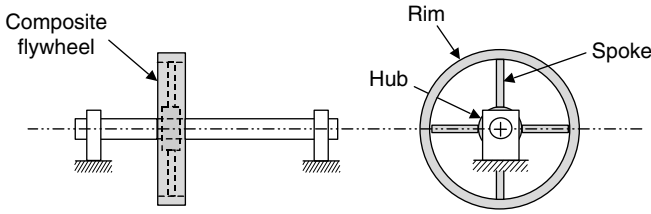

FIGURE 9.13 Composite flywheel.

where there are three main elements: (1) an inner hub, (2) an outer rim, and (3) spokes to connect the hub and rim. This type of flywheel is called a composite flywheel, because it is constructed of composite elements, elements for which individual mass moments of inertia are already known.

The number of spokes varies widely. Only four spokes are shown in Fig. 9.13; however, eight or even more are not uncommon. Also, the cross-sectional shape of the spokes varies widely. If the flywheel is cast as one piece, then the cross sections are usually elliptical or a variation of elliptical. If the flywheel is a built-up weldment, then the spokes are usually solid, circular rods.

Using the dimensional nomenclature shown in Fig. 9.14, which is an enlargement of the composite flywheel shown in Fig. 9.13, the total mass moment of inertia can be determined as the sum of three mass moments of inertia, one for each of the three main elements: hub, rim, and spokes.

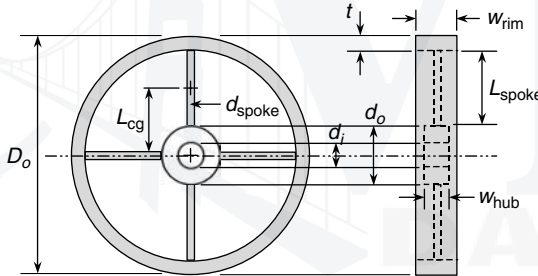

FIGURE 9.14 Composite flywheel dimensions.

For the hub, the mass moment of inertia is given by Eq. (9.75)

$$I_{\text{hub}} = \frac{1}{2} m_{\text{hub}} (r_o^2 - r_i^2) = \frac{1}{8} m_{\text{hub}} (d_o^2 - d_i^2) \quad (9.75)$$

where the mass of the hub (m_{hub}) is given by Eq. (9.76).

$$m_{\text{hub}} = \rho \pi w_{\text{hub}} (r_o^2 - r_i^2) = \frac{1}{4} \rho \pi w_{\text{hub}} (d_o^2 - d_i^2) \quad (9.76)$$

For the rim, the mass moment of inertia is given by Eq. (9.77)

$$I_{\text{rim}} = m_{\text{rim}} r_o^2 = \frac{1}{4} m_{\text{rim}} d_o^2 \quad (9.77)$$

where the mass of the rim (m_{rim}) is given by Eq. (9.78).

$$m_{\text{rim}} = 2 \rho \pi r_o t w_{\text{rim}} = \rho \pi d_o t w_{\text{rim}} \quad (9.78)$$

For each spoke, the mass moment of inertia is given by Eq. (9.79)

$$I_{\text{spoke}} = m_{\text{spoke}} \left(\frac{1}{12} L_{\text{spoke}}^2 + L_{\text{cg}}^2 \right) \tag{9.79}$$

where the mass of each spoke (m_{spoke}) is given by Eq. (9.80).

$$m_{\text{spoke}} = \rho \pi L_{\text{spoke}} r_{\text{spoke}}^2 = \frac{1}{4} \rho \pi L_{\text{spoke}} d_{\text{spoke}}^2 \tag{9.80}$$

Therefore, the total mass moment of inertia of the flywheel (I_{flywheel}) is

$$I_{\text{flywheel}} = I_{\text{hub}} + I_{\text{rim}} + N_{\text{spokes}} I_{\text{spoke}} \tag{9.81}$$

where (N_{spokes}) is the number of spokes.

Consider the following design option. In Example 1, the mass moment of inertia was calculated for a thin solid circular disk. To improve the efficiency of this flywheel, a composite design is considered. If the overall outside diameter remains the same, and using four circular rods as spokes, compare the weight of a composite flywheel similar to Fig. 9.14 with the weight of a solid disk flywheel of equal mass moment of inertia.

U.S. Customary	SI/Metric
<p>Example 5. Compare the weight of a composite flywheel design as shown in Fig. 9.14 with the thin, solid disk flywheel of Example 1, where</p> <p> $I_{\text{flywheel}} = 29.80 \text{ slug} \cdot \text{ft}^2$ (Example 1) $\rho = 15.2 \text{ slug/ft}^3$ (steel) $D_o = 3 \text{ ft}$ (Example 1) $d_o = 6 \text{ in} = 0.5 \text{ ft}$ (hub) $d_i = 3 \text{ in} = 0.25 \text{ ft}$ (hub) $w_{\text{hub}} = 3 \text{ in} = 0.25 \text{ ft}$ $t = 3 \text{ in} = 0.25 \text{ ft}$ (rim) $L_{\text{spoke}} = 12 \text{ in} = 1 \text{ ft}$ $d_{\text{spoke}} = 1.5 \text{ in} = 0.125 \text{ ft}$ $L_{\text{cg}} = 9 \text{ in} = 0.75 \text{ ft}$ </p> <p>w_{rim} is the only unknown dimension</p> <p>solution</p> <p><i>Step 1.</i> Calculate the weight of the thin solid disk flywheel in Example 1.</p> $W_{\text{solid disk}} = m_{\text{solid disk}} g$ <p>where the mass of the solid disk is found by multiplying density times its volume.</p> $m_{\text{solid disk}} = \rho \underbrace{\frac{1}{4} \pi t (d_o^2 - d_i^2)}_{\text{volume}}$ $= \left(15.2 \frac{\text{slug}}{\text{ft}^3} \right) \frac{1}{4} \pi (0.25 \text{ ft}) \times ((3 \text{ ft})^2 - (0.25 \text{ ft})^2)$	<p>Example 5. Compare the weight of a composite flywheel design like shown in Fig. 9.14 with the thin solid disk flywheel of Example 1, where</p> <p> $I_{\text{flywheel}} = 39.85 \text{ kg} \cdot \text{m}^2$ (Example 1) $\rho = 7,850 \text{ kg/m}^3$ (steel) $D_o = 90 \text{ cm} = 0.9 \text{ m}$ (Example 1) $d_o = 16 \text{ cm} = 0.16 \text{ m}$ (hub) $d_i = 8 \text{ cm} = 0.08 \text{ m}$ (hub) $w_{\text{hub}} = 8 \text{ cm} = 0.08 \text{ m}$ $t = 7 \text{ cm} = 0.07 \text{ m}$ (rim) $L_{\text{spoke}} = 30 \text{ cm} = 0.3 \text{ m}$ $d_{\text{spoke}} = 4 \text{ cm} = 0.04 \text{ m}$ $L_{\text{cg}} = 23 \text{ cm} = 0.23 \text{ m}$ </p> <p>w_{rim} is the only unknown dimension</p> <p>solution</p> <p><i>Step 1.</i> Calculate the weight of the thin solid disk flywheel in Example 1.</p> $W_{\text{solid disk}} = m_{\text{solid disk}} g$ <p>where the mass of the solid disk is found by multiplying density times its volume.</p> $m_{\text{solid disk}} = \rho \underbrace{\frac{1}{4} \pi t (d_o^2 - d_i^2)}_{\text{volume}}$ $= \left(7,850 \frac{\text{kg}}{\text{m}^3} \right) \frac{1}{4} \pi (0.08 \text{ m}) \times ((0.9 \text{ m})^2 - (0.08 \text{ m})^2)$

U.S. Customary	SI/Metric
$m_{\text{solid disk}} = \left(2.98 \frac{\text{slug}}{\text{ft}^2} \right) \times (8.94 \text{ ft}^2)$ $= 26.7 \text{ slug}$ <p>Therefore, the weight of the flywheels is</p> $W_{\text{solid disk}} = m_{\text{solid disk}} g$ $= (26.7 \text{ slug}) \left(32.2 \frac{\text{ft}}{\text{s}^2} \right)$ $= 860 \text{ lb}$ <p><i>Step 2.</i> Calculate the weight of the hub of the composite flywheel.</p> $W_{\text{hub}} = m_{\text{hub}} g$ <p>where the mass of the hub is found from Eq. (9.76) as</p> $m_{\text{hub}} = \frac{1}{4} \rho \pi w_{\text{hub}} (d_o^2 - d_i^2)$ $= \frac{1}{4} \left(15.2 \frac{\text{slug}}{\text{ft}^3} \right) \pi (0.25 \text{ ft})$ $\times ((0.5 \text{ ft})^2 - (0.25 \text{ ft})^2)$ $= \left(2.98 \frac{\text{slug}}{\text{ft}^2} \right) \times (0.1875 \text{ ft}^2)$ $= 0.56 \text{ slug}$ <p>Therefore, the weight of the hub is</p> $W_{\text{hub}} = m_{\text{hub}} g$ $= (0.56 \text{ slug}) \left(32.2 \frac{\text{ft}}{\text{s}^2} \right)$ $= 18 \text{ lb}$ <p><i>Step 3.</i> Calculate the mass moment of inertial of the hub using Eq. (9.75).</p> $I_{\text{hub}} = \frac{1}{8} m_{\text{hub}} (d_o^2 - d_i^2)$ $= \frac{1}{8} (0.56 \text{ slug})$ $\times ((0.5 \text{ ft})^2 - (0.25 \text{ ft})^2)$ $= \frac{1}{8} (0.56 \text{ slug}) \times (0.1875 \text{ ft}^2)$ $= 0.013 \text{ slug} \cdot \text{ft}^2$	$m_{\text{solid disk}} = \left(493.2 \frac{\text{kg}}{\text{m}^2} \right) \times (0.8036 \text{ m}^2)$ $= 396.4 \text{ kg}$ <p>Therefore, the weight of the flywheels is</p> $W_{\text{solid disk}} = m_{\text{solid disk}} g$ $= (396.4 \text{ kg}) \left(9.8 \frac{\text{m}}{\text{s}^2} \right)$ $= 3,884 \text{ N}$ <p><i>Step 2.</i> Calculate the weight of the hub of the composite flywheel.</p> $W_{\text{hub}} = m_{\text{hub}} g$ <p>where the mass of the hub is found from Eq. (9.76) as</p> $m_{\text{hub}} = \frac{1}{4} \rho \pi w_{\text{hub}} (d_o^2 - d_i^2)$ $= \frac{1}{4} \left(7,850 \frac{\text{kg}}{\text{m}^3} \right) \pi (0.08 \text{ m})$ $\times ((0.16 \text{ m})^2 - (0.08 \text{ m})^2)$ $= \left(493.2 \frac{\text{kg}}{\text{m}^2} \right) \times (0.0192 \text{ m}^2)$ $= 9.47 \text{ kg}$ <p>Therefore, the weight of the hub is</p> $W_{\text{hub}} = m_{\text{hub}} g$ $= (9.47 \text{ kg}) \left(9.8 \frac{\text{m}}{\text{s}^2} \right)$ $= 93 \text{ N}$ <p><i>Step 3.</i> Calculate the mass moment of inertia of the hub using Eq. (9.75).</p> $I_{\text{hub}} = \frac{1}{8} m_{\text{hub}} (d_o^2 - d_i^2)$ $= \frac{1}{8} (9.47 \text{ kg})$ $\times ((0.16 \text{ m})^2 - (0.08 \text{ m})^2)$ $= \frac{1}{8} (9.47 \text{ kg}) \times (0.0192 \text{ m}^2)$ $= 0.023 \text{ kg} \cdot \text{m}^2$

U.S. Customary	SI/Metric
<p><i>Step 4.</i> Calculate the weight of the four spokes of the composite flywheel.</p> $W_{\text{spokes}} = 4 m_{\text{spoke}} g$ <p>where the mass of the one spoke is found from Eq. (9.80) as</p> $\begin{aligned} m_{\text{spoke}} &= \frac{1}{4} \rho \pi L_{\text{spoke}} d_{\text{spoke}}^2 \\ &= \frac{1}{4} \left(15.2 \frac{\text{slug}}{\text{ft}^3} \right) \pi (1 \text{ ft}) \\ &\quad \times (0.125 \text{ ft})^2 \\ &= \left(11.94 \frac{\text{slug}}{\text{ft}^2} \right) \times (0.0156 \text{ ft}^2) \\ &= 0.19 \text{ slug} \end{aligned}$ <p>Therefore, the weight of the four spokes is</p> $\begin{aligned} W_{\text{spokes}} &= 4 m_{\text{spoke}} g \\ &= 4 (0.19 \text{ slug}) \left(32.2 \frac{\text{ft}}{\text{s}^2} \right) \\ &= 4 (6 \text{ lb}) = 24 \text{ lb} \end{aligned}$ <p><i>Step 5.</i> Calculate the mass moment of inertia of one spoke using Eq. (9.79).</p> $\begin{aligned} I_{\text{spoke}} &= m_{\text{spoke}} \left(\frac{1}{12} L_{\text{spoke}}^2 + L_{\text{cg}}^2 \right) \\ &= (0.19 \text{ slug}) \\ &\quad \times \left(\frac{1}{12} (1 \text{ ft})^2 + (0.75 \text{ ft})^2 \right) \\ &= (0.19 \text{ slug}) \times (0.646 \text{ ft}^2) \\ &= 0.123 \text{ slug} \cdot \text{ft}^2 \end{aligned}$ <p><i>Step 6.</i> Using Eq. (9.81) and the mass moment of inertia from Example 1 and the mass moments of inertia for the hub and one spoke found in steps 3 and 5, respectively, determine the mass moment of inertia needed from the rim.</p> $\begin{aligned} I_{\text{flywheel}} &= I_{\text{hub}} + I_{\text{rim}} + N_{\text{spokes}} I_{\text{spoke}} \\ 29.80 \text{ slug} \cdot \text{ft}^2 &= (0.013 \text{ slug} \cdot \text{ft}^2) + I_{\text{rim}} \\ &\quad + (4)(0.123 \text{ slug} \cdot \text{ft}^2) \end{aligned}$ <p>Solving for (I_{rim}) gives</p> $\begin{aligned} I_{\text{rim}} &= (29.80 - 0.013 - 0.492) \text{ slug} \cdot \text{ft}^2 \\ &= 29.3 \text{ slug} \cdot \text{ft}^2 \end{aligned}$	<p><i>Step 4.</i> Calculate the weight of the four spokes of the composite flywheel.</p> $W_{\text{spokes}} = 4 m_{\text{spoke}} g$ <p>where the mass of the one spoke is found from Eq. (9.80) is</p> $\begin{aligned} m_{\text{spoke}} &= \frac{1}{4} \rho \pi L_{\text{spoke}} d_{\text{spoke}}^2 \\ &= \frac{1}{4} \left(7,850 \frac{\text{kg}}{\text{m}^3} \right) \pi (0.3 \text{ m}) \\ &\quad \times (0.04 \text{ m})^2 \\ &= \left(1,850 \frac{\text{kg}}{\text{m}^2} \right) \times (0.0016 \text{ m}^2) \\ &= 2.96 \text{ kg} \end{aligned}$ <p>Therefore, the weight of the four spokes is</p> $\begin{aligned} W_{\text{spokes}} &= 4 m_{\text{spoke}} g \\ &= 4 (2.96 \text{ kg}) \left(9.8 \frac{\text{m}}{\text{s}^2} \right) \\ &= 4 (29 \text{ N}) = 116 \text{ N} \end{aligned}$ <p><i>Step 5.</i> Calculate the mass moment of inertia of one spoke using Eq. (9.79).</p> $\begin{aligned} I_{\text{spoke}} &= m_{\text{spoke}} \left(\frac{1}{12} L_{\text{spoke}}^2 + L_{\text{cg}}^2 \right) \\ &= (2.96 \text{ kg}) \\ &\quad \times \left(\frac{1}{12} (0.3 \text{ m})^2 + (0.23 \text{ m})^2 \right) \\ &= (2.96 \text{ kg}) \times (0.0604 \text{ m}^2) \\ &= 0.179 \text{ kg} \cdot \text{m}^2 \end{aligned}$ <p><i>Step 6.</i> Using Eq. (9.81) and the mass moment of inertia from Example 1 and the mass moments of inertia for the hub and one spoke found in steps 3 and 5, respectively, determine the mass moment of inertia needed from the rim.</p> $\begin{aligned} I_{\text{flywheel}} &= I_{\text{hub}} + I_{\text{rim}} + N_{\text{spokes}} I_{\text{spoke}} \\ 39.85 \text{ kg} \cdot \text{m}^2 &= (0.023 \text{ kg} \cdot \text{m}^2) + I_{\text{rim}} \\ &\quad + (4)(0.179 \text{ kg} \cdot \text{m}^2) \end{aligned}$ <p>Solving for (I_{rim}) gives</p> $\begin{aligned} I_{\text{rim}} &= (39.85 - 0.023 - 0.716) \text{ kg} \cdot \text{m}^2 \\ &= 39.1 \text{ kg} \cdot \text{m}^2 \end{aligned}$

U.S. Customary	SI/Metric
<p>Note that the mass moments of inertia of the hub and spokes are very small.</p>	<p>Note that the mass moments of inertia of the hub and spokes are very small.</p>
<p><i>Step 7.</i> Using the mass moment of inertia needed from the rim of the composite flywheel found in step 6 and Eq. (9.77), determine the required mass of the rim (m_{rim}) as</p>	<p><i>Step 7.</i> Using the mass moment of inertia needed from the rim of the composite flywheel found in step 6 and Eq. (9.77), determine the required mass of the rim (m_{rim}) as</p>
$I_{\text{rim}} = \frac{1}{4} m_{\text{rim}} d_o^2$ $29.3 \text{ slug} \cdot \text{ft}^2 = \frac{1}{4} m_{\text{rim}} d_o^2$	$I_{\text{rim}} = \frac{1}{4} m_{\text{rim}} d_o^2$ $39.1 \text{ kg} \cdot \text{m}^2 = \frac{1}{4} m_{\text{rim}} d_o^2$
<p>Solve for (m_{rim})</p>	<p>Solve for (m_{rim})</p>
$m_{\text{rim}} = \frac{4(29.3 \text{ slug} \cdot \text{ft}^2)}{d_o^2}$ $= \frac{4(29.3 \text{ slug} \cdot \text{ft}^2)}{(3 \text{ ft})^2}$ $= \frac{117.2 \text{ slug} \cdot \text{ft}^2}{9 \text{ ft}^2}$ $= 13 \text{ slug}$	$m_{\text{rim}} = \frac{4(39.1 \text{ kg} \cdot \text{m}^2)}{d_o^2}$ $= \frac{4(39.1 \text{ kg} \cdot \text{m}^2)}{(0.9 \text{ m})^2}$ $= \frac{156.4 \text{ kg} \cdot \text{m}^2}{0.81 \text{ m}^2}$ $= 193 \text{ kg}$
<p><i>Step 8.</i> Using the mass of the rim found in step 7, determine the required width of the rim from Eq. (9.78) as</p>	<p><i>Step 8.</i> Using the mass of the rim found in step 7, determine the required width of the rim from Eq. (9.78) as</p>
$m_{\text{rim}} = \rho \pi d_o t w_{\text{rim}}$ $13 \text{ slug} = \left(15.2 \frac{\text{slug}}{\text{ft}^3}\right) \pi (3 \text{ ft})$ $\quad \times (0.25 \text{ ft}) w_{\text{rim}}$ $= \left(35.8 \frac{\text{slug}}{\text{ft}}\right) w_{\text{rim}}$ $w_{\text{rim}} = \frac{13 \text{ slug}}{\left(35.8 \frac{\text{slug}}{\text{ft}}\right)} = 0.363 \text{ ft} = 4.36 \text{ in}$	$m_{\text{rim}} = \rho \pi d_o t w_{\text{rim}}$ $193 \text{ kg} = \left(7,850 \frac{\text{kg}}{\text{m}^3}\right) \pi (0.9 \text{ m})$ $\quad \times (0.07 \text{ m}) w_{\text{rim}}$ $= \left(1,554 \frac{\text{kg}}{\text{m}}\right) w_{\text{rim}}$ $w_{\text{rim}} = \frac{193 \text{ kg}}{\left(1,554 \frac{\text{kg}}{\text{m}}\right)} = 0.124 \text{ m} = 12.4 \text{ cm}$
<p><i>Step 9.</i> Using the mass of the rim found in step 7, determine the weight of the rim as</p>	<p><i>Step 9.</i> Using the mass of the rim found in step 7, determine the weight of the rim as</p>
$W_{\text{rim}} = m_{\text{rim}} g$ $= (13 \text{ slug}) \left(32.2 \frac{\text{ft}}{\text{s}^2}\right)$ $= 419 \text{ lb}$	$W_{\text{rim}} = m_{\text{rim}} g$ $= (193 \text{ kg}) \left(9.8 \frac{\text{m}}{\text{s}^2}\right)$ $= 1,891 \text{ N}$
<p><i>Step 10.</i> Calculate the total weight of the composite flywheel using the weights of the hub, spokes, and rim found in steps 2, 4, and 9, respectively.</p>	<p><i>Step 10.</i> Calculate the total weight of the composite flywheel using the weights of the hub, spokes, and rim found in steps 2, 4, and 9, respectively.</p>
$W_{\text{composite flywheel}} = W_{\text{hub}} + W_{\text{spokes}} + W_{\text{rim}}$ $= (18) + (24) + (419) \text{ lb}$ $= 461 \text{ lb}$	$W_{\text{composite flywheel}} = W_{\text{hub}} + W_{\text{spokes}} + W_{\text{rim}}$ $= (93) + (116) + (1,891) \text{ N}$ $= 2,100 \text{ N}$

U.S. Customary	SI/Metric
<p><i>Step 11.</i> Compare the total weight of the composite flywheel found in step 10 with the weight of the solid disk flywheel found in step 1.</p> $\frac{W_{\text{solid disk}}}{W_{\text{composite flywheel}}} = \frac{860 \text{ lb}}{461 \text{ lb}} = 1.87$	<p><i>Step 11.</i> Compare the total weight of the composite flywheel found in step 10 with the weight of the solid disk flywheel found in step 1.</p> $\frac{W_{\text{solid disk}}}{W_{\text{composite flywheel}}} = \frac{3,884 \text{ N}}{2,100 \text{ N}} = 1.85$

This example shows that a composite flywheel can be designed that has the same mass moment of inertia as a solid disk flywheel; however, it only weighs a little over half as much. Also, the width of the rim was the only dimension that was unknown, and it came out to be only 50 percent wider than the thickness of the solid disk flywheel.

This concludes the discussion on the two most important design elements associated with machine energy: helical springs and flywheels. The next chapter discusses machine motion, which includes all the design information on the three most famous mechanisms: slider-crank, four-bar, and quick-return mechanisms. Also included are discussions on both spur and planetary gear systems, and the motion of pulleys and wheels.



This page intentionally left blank.

CHAPTER 10

MACHINE MOTION

10.1 INTRODUCTION

In this chapter, the motion of three major groups of machine elements will be discussed: linkages, gear trains, and wheels and pulleys. Virtually every machine has one or more elements from one of these groups as part of its critical design requirements. All three groups are very important to the machine designer; therefore, each group will be discussed with examples in both the U.S. Customary and SI/metric system of units.

Linkages comprise almost an endless variety of ingenious devices used in countless ways by machine designers to achieve specific desired motions. Virtually all these linkages were *discovered* or *invented* rather than being formally *created* from an analytic analysis. Therefore, there is usually great mystery concerning how these linkages actually achieve the motions they produce. The purpose of this book is to uncover the mystery of machine design formulas; therefore, this will be the purpose of this chapter. While the motion of every conceivable linkage cannot be discussed here, there are fundamental principles and formulas that allow machine designers to uncover for themselves the mystery of a particular linkage of interest. These fundamental principles and formulas, which relate the relative motions between elements of a linkage, will be discussed in detail and then will be applied to the most classic of the linkages, the slider-crank mechanism.

Gear trains fall into two main categories: spur and planetary. There are certainly other types of gear arrangements: bevel, hypoid bevel, and worm; however, these gear sets do not tend to be combined in multiple configurations, and therefore, their motion is rather straightforward. In contrast, spur-type gears, including helical and double helical gears, are usually arranged so that more than one gear is on each shaft and more than two shafts comprise the overall assembly. Determining the ratio of the input motion to the output motion can be daunting for the machine designer. Even more complex motion is present in a planetary gear train, where spur-type gears rotate about their own axis while rotating about another axis in a *planetary* motion and that is where the name derives from. Determining the ratio of the input motion to the output motion can be very intimidating to the machine designer.

Wheels and pulleys are two of the truly fundamental machine elements, along with the lever and fulcrum and the inclined plane. It is almost trivial to say that the motion of the rolling wheel is important to the machine designer; however, it is, and therefore its complete motion along a variety of paths will be presented in detail. Pulleys can either rotate simply about a fixed axis or be combined in complex arrangements where some pulleys will rotate about their own axis while rolling up or down a cable or belt like a rolling wheel. The usual purpose of pulley systems is to provide a mechanical advantage, that is, provide a large output force from a small input force; however, this typically means that the speed of the motion is greatly reduced. These and other design considerations will be discussed.

10.2 LINKAGES

Linkages, also called mechanisms, transfer motion from one machine element to another. They also transfer loads; however, it is the motion that is usually the mystery and once that is understood the rest of the required design calculations become clear.

In *Marks' Standard Handbook for Mechanical Engineers* the term mechanism is defined as "that part of a machine which contains two or more pieces so arranged that the motion of one compels the motion of the others, all in a fashion prescribed by the nature of the combination." This is a great definition. The key words are *compels*, *prescribed*, and *nature*. All the three of these key words describe not only the complexity of a mechanism, but also its beauty and uniqueness.

There are three classic designs on which many variations are built: the four-bar linkage, the quick-return linkage, and the slider-crank linkage. The combination of *pieces* in each of these linkages is *compelled* to move in *prescribed* motions by the *nature* of the combination as a consequence of the relative motion relationships that must exist between the pieces. These relative motion relationships will be applied to the motion of the slider-crank linkage presented later in this section.

10.2.1 Classic Designs

The first of three classic designs is the four-bar linkage, shown in Fig. 10.1, where bar (1) is called the crank, bar (2) is called the link, bar (3) is called the lever, and bar (4) is the ground. Depending on the relative lengths of the three moving bars, (1), (2), and (3), and the distance between points *A* and *D*, which acts as the fourth bar (4), there will be a precise relationship between the motion of the crank and the lever.

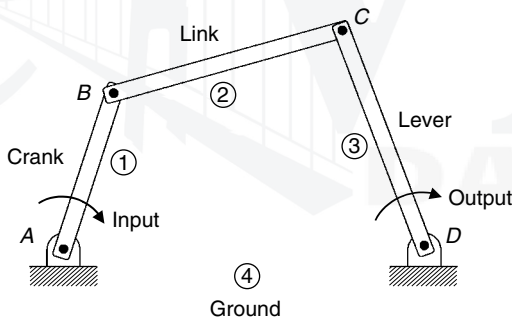

FIGURE 10.1 Four-bar linkage.

Because of the precise relationship that can be achieved between the crank and the lever in this linkage, it has been used in mechanical computers in both military and industrial applications. It is also used in many automotive applications.

The second classic design is the quick-return linkage, shown in two variations, (a) and (b), in Fig. 10.2, where (1) is called the crank and (2) is called the arm.

For the quick-return linkage design in Fig. 10.2(a), the pin at point *C* is connected to a sliding block that rides in the slot of the arm. For the design in Fig. 10.2(b), the pin at point *C* is connected to a collar that slides on the outside of the arm.

Depending on the relative length of the crank (1) and the distance between points *A* and *B*, the arm (2) will pivot about point *B* slower as the crank rotates above point *A* than it will as the crank rotates below point *A*, meaning it will have a *quick* return during

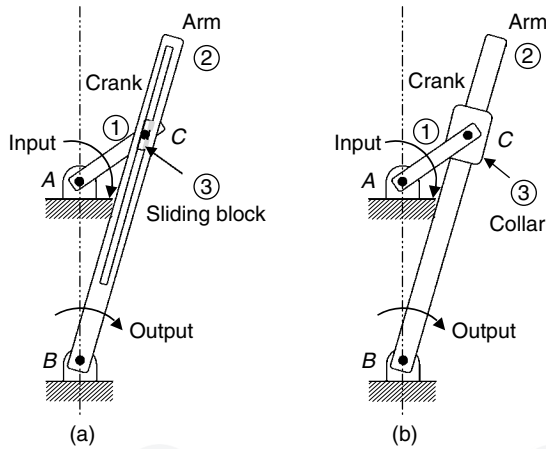

FIGURE 10.2 Quick-return linkages.

each complete rotation of the crank. Quick-return linkages are commonly used in automated machining operations, where the slower motion occurs during the actual material removal step and the faster motion returns the cutting tool to its initial position for the next pass.

The third classic design is the slider-crank linkage, shown in Fig. 10.3, where (1) is called the crank, (2) is called the connecting rod, and (3) is called the slider; hence the name slider-crank.

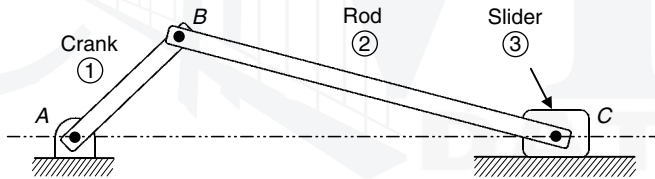

FIGURE 10.3 Slider-crank linkage.

Unlike the quick-return linkage where the crank always drives the arm, the slider-crank linkage can have either the crank driving the slider or the slider driving the crank. For example, in a reciprocating air compressor, a motor drives the crank that in turn drives the piston to compress the air. In contrast, the pistons in an internal combustion engine drive the crank, specifically the crankshaft, which in turn can drive the wheels of a car through the transmission and differential. This is probably one of the most versatile linkages available to the designer.

Note that points A and C in Fig. 10.3 lie along the same horizontal axis. However, the surface on which the slider rides can be located such that point C is either above or below point A. Also, the orientation of the slider-crank linkage in Fig. 10.3 is horizontal. This linkage can easily be oriented vertically, or at any angle in between.

Before beginning the discussion on the detailed motion of the slider-crank linkage, which is based on the relative lengths of the crank (1) and the rod (2), the relative motion relationships between mechanical elements connected to a linkage will be presented.

10.2.2 Relative Motion

Consider the motion of the slider-crank linkage shown in Fig. 10.3, and assume the crank (1) drives the slider (3). Therefore, the motion of the crank will be known completely, and because it is in *pure rotation* about point A, this means only its angular velocity (ω_{crank}) and angular acceleration (α_{crank}) must be specified. Pure rotation means that every point on this element of the linkage moves in a circle about the point A.

On the other hand, the motion of the slider (3) is constrained to move in *pure translation* along the horizontal surface; however, the magnitude and direction (left or right) of its velocity (v_{slider}) and acceleration (a_{slider}) will vary. Pure translation means every point on this element of the linkage moves in a straight line.

Connecting the crank and slider is the connecting rod (2) which moves in *general plane motion*, which is a combination of *pure rotation* and *pure translation*. Therefore, its angular velocity (ω_{rod}) and angular acceleration (α_{rod}) will vary, depending on the relative lengths of the crank (1) and connecting rod (2) and the given magnitude and direction (clockwise or counterclockwise) of the angular velocity (ω_{crank}) and angular acceleration (α_{crank}) of the crank.

Therefore, there are two unknowns associated with velocity: the velocity of the slider (v_{slider}) and the angular velocity of the rod (ω_{rod}). Similarly, there are two unknowns associated with acceleration: the acceleration of the slider (a_{slider}) and the angular acceleration of the rod (α_{rod}). To determine two unknowns, two equations are needed, one set for velocity and the other set for acceleration. These equations are provided from the relative motion relationships that must exist between the elements of the linkage.

Velocity Analysis. As the motion of even the simplest linkage is complex, the velocity analysis begins by separating the linkage into its individual elements. This might be called the “golden rule” of linkage analysis, that is, always separate the linkage into its individual elements, each with its own unique motion.

In Fig. 10.4, the slider-crank linkage shown in Fig. 10.3 has been separated into its three elements: the crank, the connecting rod, and the slider.

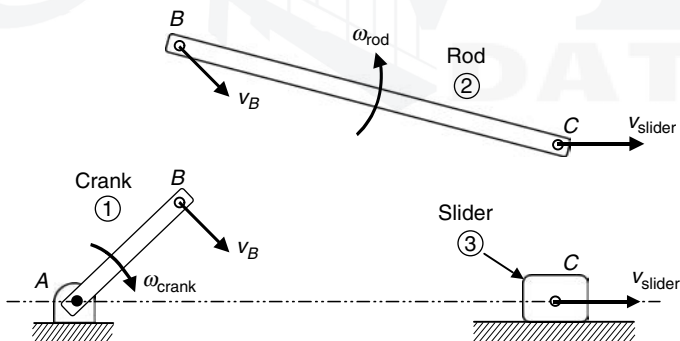

FIGURE 10.4 Slider-crank linkage separated.

Notice that the velocity of point B on the crank is of the same magnitude and direction as point B on the left end of the connecting rod, and that the velocity of point C on the right end of the connecting rod is of the same magnitude and direction as the velocity of the slider.

There is a relationship between these velocities at each end of the connecting rod, given by the vector equation

$$\vec{v}_C = \vec{v}_B + \vec{v}_{C/B} \quad (10.1)$$

where \vec{v}_C = absolute velocity of point C, meaning relative to ground
 \vec{v}_B = absolute velocity of point B, meaning relative to ground
 $\vec{v}_{C/B}$ = velocity of point C relative to point B, as if point B is fixed

These three velocity vectors are shown graphically in Fig. 10.5,

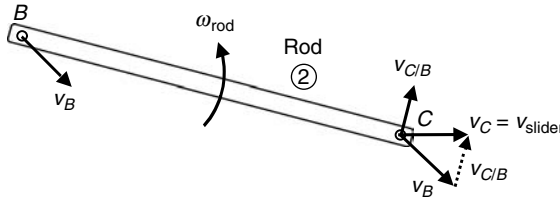

FIGURE 10.5 Vector velocities on the connecting rod.

where the vector triangle at point C represents the relationship given by Eq. (10.1).

Based on the definition of the velocity ($\vec{v}_{C/B}$), the velocity of point C relative to point B as if point B is fixed, has a magnitude given by Eq. (10.2) as

$$v_{C/B} = L_{BC} \omega_{rod} \tag{10.2}$$

and its direction is perpendicular to the line connecting points B and C of length (L_{BC}). The direction of the angular velocity (ω_{rod}) will either be clockwise (CW) or counterclockwise (CCW), determined from the vector equation defined by Eq. (10.1).

If an xy coordinate system is added, along with angles (ϕ) and (β) defining the directions of (v_B) and ($v_{C/B}$), respectively, then Fig. 10.5 becomes Fig. 10.6.

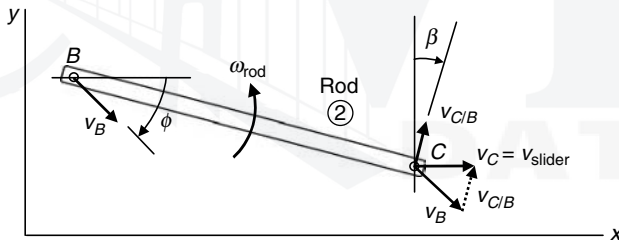

FIGURE 10.6 Vector velocities on the connecting rod.

Using Fig. 10.6, the vector equation in Eq. (10.1) can be separated into two scalar equations. One equation will represent the relationship between the velocity components in the x -direction, and the other equation will represent the relationship between the velocity components in the y -direction, respectively, as

$$x: \quad v_C = v_B \cos \phi + v_{C/B} \sin \beta \tag{10.3}$$

$$y: \quad 0 = -v_B \sin \phi + v_{C/B} \cos \beta \tag{10.4}$$

where the velocity (v_C) has a horizontal component, but its vertical component is zero.

Setting the velocity (v_C) equal to the velocity of the slider (v_{slider}) and substituting for ($v_{C/B}$) from Eq. (10.2) in Eqs. (10.3) and (10.4) gives

$$x: \quad v_{slider} = v_B \cos \phi + (L_{BC} \omega_{rod}) \sin \beta \tag{10.5}$$

$$y: \quad 0 = -v_B \sin \phi + (L_{BC} \omega_{rod}) \cos \beta \tag{10.6}$$

Solving for the angular velocity (ω_{rod}) in Eq. (10.6) gives

$$\omega_{rod} = \frac{v_B \sin \phi}{L_{BC} \cos \beta} \quad (10.7)$$

Substituting the angular velocity (ω_{rod}) from Eq. (10.7) in Eq. (10.5) and simplifying gives the velocity of the slider (v_{slider}) as

$$\begin{aligned} v_{slider} &= v_B \cos \phi + L_{BC} \left(\frac{v_B \sin \phi}{L_{BC} \cos \beta} \right) \sin \beta \\ &= v_B \cos \phi + v_B \sin \phi \tan \beta \\ &= v_B (\cos \phi + \sin \phi \tan \beta) \end{aligned} \quad (10.8)$$

Similar to the expression for the velocity (v_{BC}) given by Eq. (10.2), the velocity (v_B) is given by Eq. (10.9) as

$$v_B = L_{AB} \omega_{crank} \quad (10.9)$$

Substituting for the velocity (v_B) from Eq. (10.9) in Eq. (10.7) gives

$$\begin{aligned} \omega_{rod} &= \frac{v_B \sin \phi}{L_{BC} \cos \beta} = \frac{(L_{AB} \omega_{crank}) \sin \phi}{L_{BC} \cos \beta} \\ &= \left(\frac{L_{AB}}{L_{BC}} \right) \left(\frac{\sin \phi}{\cos \beta} \right) \omega_{crank} \end{aligned} \quad (10.10)$$

and substituting for the velocity (v_B) from Eq. (10.9) in Eq. (10.8) gives

$$\begin{aligned} v_{slider} &= v_B (\cos \phi + \sin \phi \tan \beta) \\ &= (L_{AB} \omega_{crank}) (\cos \phi + \sin \phi \tan \beta) \end{aligned} \quad (10.11)$$

The angular velocity of the crank (ω_{crank}), the lengths (L_{AB}) and (L_{BC}), and the angle (ϕ) are part of the given information. Therefore, only the angle (β) is left to be determined.

The geometry of a particular orientation of the crank, connecting rod, and slider is shown in Fig. 10.7.

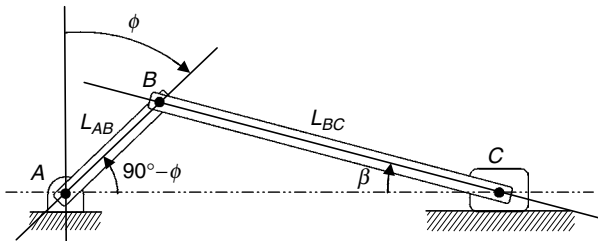

FIGURE 10.7 Geometry of the slider-crank linkage.

As the angle (ϕ) of the crank and the lengths (L_{AB}) and (L_{BC}) are known, the angle (β) can be determined from Fig. 10.7 using the law of sines as

$$\frac{\sin \beta}{L_{AB}} = \frac{\sin(90^\circ - \phi)}{L_{BC}}$$

$$\sin \beta = \left(\frac{L_{AB}}{L_{BC}} \right) \sin(90^\circ - \phi) \quad (10.12)$$

Using the given information and the angle (β) found from Eq. (10.12), the angular velocity of the connecting rod (ω_{rod}) can now be calculated from Eq. (10.10) and the velocity of the slider (v_{slider}) can be calculated from Eq. (10.11).

As the angle (β) must be found using an equation based on applying the law of sines to a scalene triangle that continually changes shape, there is no closed-form solution for the angular velocity of the connecting rod and the velocity of the slider. Therefore, the analysis must be done for multiple positions of the angle (ϕ).

U.S. Customary	SI/Metric
<p>Example 1. Determine the angular velocity (ω_{rod}) and velocity (v_{slider}) for a slider-crank linkage, where</p> <p>$\omega_{\text{crank}} = 2,000 \text{ rpm}$ $\phi = 50^\circ$ $L_{AB} = 3 \text{ in}$ $L_{BC} = 8 \text{ in}$</p> <p>solution</p> <p><i>Step 1.</i> Convert the angular velocity (ω_{crank}) from (rpm) to (rad/s) as</p> $\omega_{\text{crank}} = 2,000 \frac{\text{rev}}{\text{min}} \times \frac{2\pi \text{ rad}}{1 \text{ rev}} \times \frac{1 \text{ min}}{60 \text{ s}}$ $= 209 \text{ rad/s}$ <p><i>Step 2.</i> Substitute the given angle (ϕ), and the lengths (L_{AB}) and (L_{BC}), in Eq. (10.11) to determine the angle (β) as</p> $\sin \beta = \left(\frac{L_{AB}}{L_{BC}} \right) \sin(90^\circ - \phi)$ $= \left(\frac{3 \text{ in}}{8 \text{ in}} \right) \sin(90^\circ - 50^\circ)$ $= (0.375) \sin 40^\circ$ $= 0.241$ $\beta = \sin^{-1}(0.241) = 14^\circ$	<p>Example 1. Determine the angular velocity (ω_{rod}) and velocity (v_{slider}) for a slider-crank linkage, where</p> <p>$\omega_{\text{crank}} = 2,000 \text{ rpm}$ $\phi = 50^\circ$ $L_{AB} = 7.5 \text{ cm}$ $L_{BC} = 20 \text{ cm}$</p> <p>solution</p> <p><i>Step 1.</i> Convert the angular velocity (ω_{crank}) from (rpm) to (rad/s) as</p> $\omega_{\text{crank}} = 2,000 \frac{\text{rev}}{\text{min}} \times \frac{2\pi \text{ rad}}{1 \text{ rev}} \times \frac{1 \text{ min}}{60 \text{ s}}$ $= 209 \text{ rad/s}$ <p><i>Step 2.</i> Substitute the given angle (ϕ), and the lengths (L_{AB}) and (L_{BC}), in Eq. (10.11) to determine the angle (β) as</p> $\sin \beta = \left(\frac{L_{AB}}{L_{BC}} \right) \sin(90^\circ - \phi)$ $= \left(\frac{7.5 \text{ cm}}{20 \text{ cm}} \right) \sin(90^\circ - 50^\circ)$ $= (0.375) \sin 40^\circ$ $= 0.241$ $\beta = \sin^{-1}(0.241) = 14^\circ$

U.S. Customary	SI/Metric
<p><i>Step 3.</i> Using the angular velocity (ω_{crank}) found in step 1, the angle (β) found in step 2, and the given lengths (L_{AB}) and (L_{BC}), calculate the angular velocity (ω_{rod}) using Eq. (10.10) as</p> $\begin{aligned}\omega_{\text{rod}} &= \left(\frac{L_{AB}}{L_{BC}}\right)\left(\frac{\sin \phi}{\cos \beta}\right)\omega_{\text{crank}} \\ &= \left(\frac{3 \text{ in}}{8 \text{ in}}\right)\left(\frac{\sin 50^\circ}{\cos 14^\circ}\right)\left(209 \frac{\text{rad}}{\text{s}}\right) \\ &= (0.375)(0.7895)\left(209 \frac{\text{rad}}{\text{s}}\right) \\ &= 62 \frac{\text{rad}}{\text{s}} \times \frac{1 \text{ rev}}{2\pi \text{ rad}} \times \frac{60 \text{ s}}{1 \text{ min}} \\ &= 592 \text{ rpm}\end{aligned}$ <p><i>Step 4.</i> Using the angular velocity (ω_{crank}) found in step 1, the angle (β) found in step 2, and the given length (L_{AB}), calculate the slider velocity (v_{slider}) using Eq. (10.11) as</p> $\begin{aligned}v_{\text{slider}} &= (L_{AB} \omega_{\text{crank}})(\cos \phi + \sin \phi \tan \beta) \\ &= (3 \text{ in})(209 \text{ rad/s}) \\ &\quad \times (\cos 50^\circ + \sin 50^\circ \tan 14^\circ) \\ &= (627 \text{ in/s})(0.834) \\ &= 523 \text{ in/s} = 43.6 \text{ ft/s}\end{aligned}$	<p><i>Step 3.</i> Using the angular velocity (ω_{crank}) found in step 1, the angle (β) found in step 2, and the given lengths (L_{AB}) and (L_{BC}), calculate the angular velocity (ω_{rod}) using Eq. (10.10) as</p> $\begin{aligned}\omega_{\text{rod}} &= \left(\frac{L_{AB}}{L_{BC}}\right)\left(\frac{\sin \phi}{\cos \beta}\right)\omega_{\text{crank}} \\ &= \left(\frac{7.5 \text{ cm}}{20 \text{ cm}}\right)\left(\frac{\sin 50^\circ}{\cos 14^\circ}\right)\left(209 \frac{\text{rad}}{\text{s}}\right) \\ &= (0.375)(0.7895)\left(209 \frac{\text{rad}}{\text{s}}\right) \\ &= 62 \frac{\text{rad}}{\text{s}} \times \frac{1 \text{ rev}}{2\pi \text{ rad}} \times \frac{60 \text{ s}}{1 \text{ min}} \\ &= 592 \text{ rpm}\end{aligned}$ <p><i>Step 4.</i> Using the angular velocity (ω_{crank}) found in step 1, the angle (β) found in step 2, and the given length (L_{AB}), calculate the slider velocity (v_{slider}) using Eq. (10.11) as</p> $\begin{aligned}v_{\text{slider}} &= (L_{AB} \omega_{\text{crank}})(\cos \phi + \sin \phi \tan \beta) \\ &= (7.5 \text{ cm})(209 \text{ rad/s}) \\ &\quad \times (\cos 50^\circ + \sin 50^\circ \tan 14^\circ) \\ &= (1,567.5 \text{ cm/s})(0.834) \\ &= 1,307 \text{ cm/s} = 13.1 \text{ m/s}\end{aligned}$

As the values for both the angular velocity (ω_{rod}) and the velocity of the slider (v_{slider}) are positive, their directions are as shown in Fig. 10.6. If either had turned out negative, then their direction would be opposite to that shown in Fig. 10.6.

Acceleration Analysis. As was the case for the velocity analysis, the acceleration analysis is based on the linkage being separated into its individual elements. In Fig. 10.8 the accelerations are shown in the same way the velocities were shown in Fig. 10.4 for the velocity analysis.

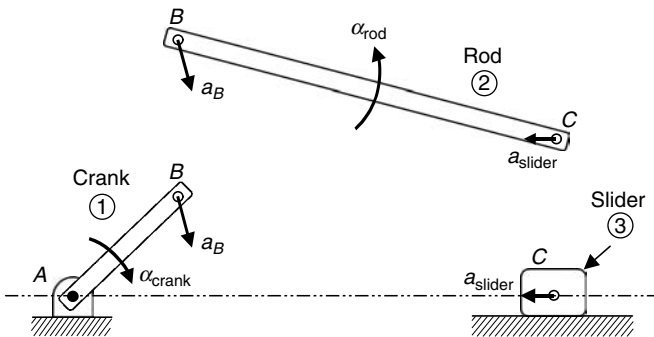

FIGURE 10.8 Slider-crank linkage separated.

As was the case for the velocity analysis, the acceleration of point B on the crank is the same as that for point B on the left end of the connecting rod, and the acceleration of point C on the right end of the connecting rod is the same as the acceleration of the slider. However, the acceleration of point B on the crank has two components, one in the same direction as the velocity (v_B) and the other is directed toward point A as shown in Fig. 10.9.

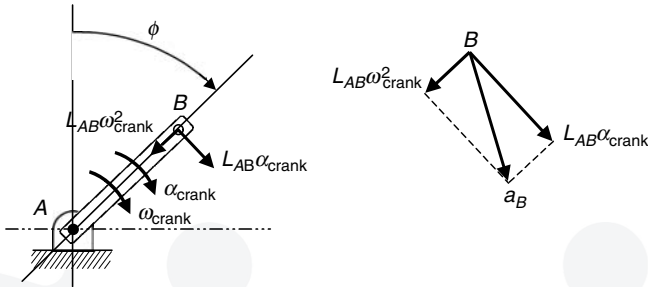

FIGURE 10.9 Components of the acceleration at point B .

The acceleration in the direction of the velocity (v_B) is called the tangential acceleration (a_B^t) and its magnitude is given by Eq. (10.13) as

$$a_B^t = L_{AB}\alpha_{\text{crank}} \quad (10.13)$$

and the acceleration toward point A is called the normal acceleration (a_B^n) and its magnitude is given by Eq. (10.14) as

$$a_B^n = L_{AB}\omega_{\text{crank}}^2 \quad (10.14)$$

The magnitude of the total acceleration (a_B) is therefore given by the Pythagorean theorem as

$$a_B = \sqrt{(a_B^t)^2 + (a_B^n)^2} = \sqrt{(L_{AB}\alpha_{\text{crank}})^2 + (L_{AB}\omega_{\text{crank}}^2)^2} \quad (10.15)$$

Note that even if the angular acceleration (α_{crank}) is zero, there is still an acceleration (a_B) equal to the normal acceleration (a_B^n) and given by Eq. (10.14).

Also, note that the acceleration of the slider (a_{slider}) shown in Fig. 10.8 is opposite to the direction of its velocity (v_{slider}), meaning the slider is slowing down. This is consistent with the orientation of the slider-crank linkage defined by the angle (ϕ).

Similar to Eq. (10.1), there is a relationship between the accelerations at each end of the connecting rod in Fig. 10.8, given by the vector equation.

$$\vec{a}_C = \vec{a}_B + \vec{a}_{C/B} \quad (10.16)$$

where \vec{a}_C = absolute acceleration of point C , meaning relative to ground

\vec{a}_B = absolute acceleration of point B , meaning relative to ground

$\vec{a}_{C/B}$ = acceleration of point C relative to point B , as if point B is fixed

These three acceleration vectors are shown graphically in Fig. 10.10, where the vector triangle at point *C* represents the relationship given by Eq. (10.16).

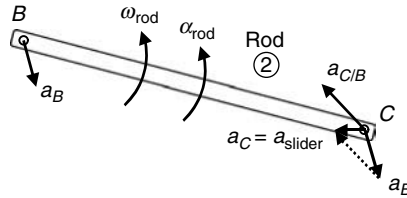

FIGURE 10.10 Vector accelerations on the connecting rod.

Similar to the acceleration of point *B*, the acceleration of point *C* on the connecting rod has two components, one in the same direction as the velocity ($v_{C/B}$) and the other is directed toward point *B* as shown in Fig. 10.11.

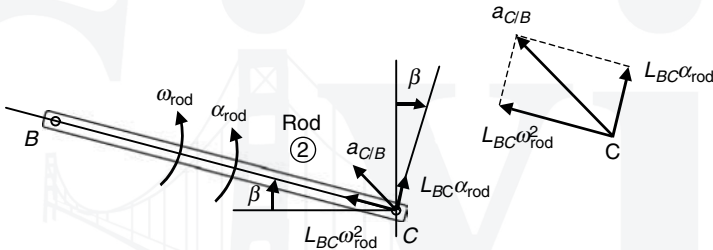

FIGURE 10.11 Components of the acceleration at point *C*.

The acceleration in the direction of the velocity ($v_{C/B}$) is the tangential acceleration ($a_{C/B}^t$) and its magnitude is given by Eq. (10.17) as

$$a_{C/B}^t = L_{BC} \alpha_{rod} \tag{10.17}$$

and the acceleration toward point *B* is the normal acceleration ($a_{C/B}^n$) and its magnitude is given by Eq. (10.18) as

$$a_{C/B}^n = L_{BC} \omega_{rod}^2 \tag{10.18}$$

The magnitude of the total acceleration ($a_{C/B}$) is therefore given by the Pythagorean theorem as

$$a_{C/B} = \sqrt{(a_{C/B}^t)^2 + (a_{C/B}^n)^2} = \sqrt{(L_{BC} \alpha_{rod})^2 + (L_{BC} \omega_{rod}^2)^2} \tag{10.19}$$

Note that even if the angular acceleration (α_{rod}) is zero, there is still an acceleration ($a_{C/B}$) equal to the normal acceleration ($a_{C/B}^n$) and given by Eq. (10.18).

If an *xy*-coordinate system is added, along with angles (ϕ) and (β) defining the directions of (a_B) and ($a_{C/B}$), respectively, then Fig. 10.12 can be used to separate the vector equation in Eq. (10.16) into two scalar equations.

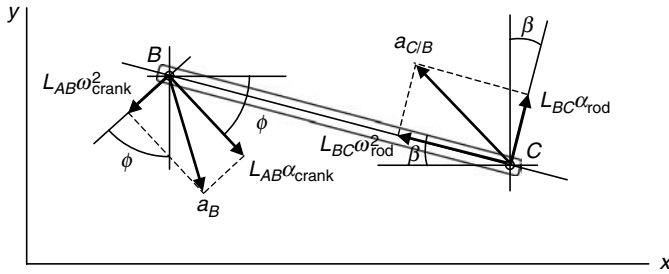

FIGURE 10.12 Vector accelerations on the connecting rod.

One equation will represent the relationship between the acceleration components in the x -direction, and the other equation will represent the relationship between the acceleration components in the y -direction, respectively, as

$$x: -a_C = -L_{AB}\omega_{\text{crank}}^2 \sin \phi + L_{AB}\alpha_{\text{crank}} \cos \phi - L_{BC}\omega_{\text{rod}}^2 \cos \beta + L_{BC}\alpha_{\text{rod}} \sin \beta \quad (10.20)$$

$$y: 0 = -L_{AB}\omega_{\text{crank}}^2 \cos \phi - L_{AB}\alpha_{\text{crank}} \sin \phi + L_{BC}\omega_{\text{rod}}^2 \sin \beta + L_{BC}\alpha_{\text{rod}} \cos \beta \quad (10.21)$$

where the acceleration (a_C) is the acceleration of the slider (a_{slider}) and has a horizontal component in the negative direction; however, its vertical component is zero.

As complex as they seem, there are only two unknowns in Eqs. (10.20) and (10.21), the acceleration of the slider (a_C) and the angular acceleration (α_{rod}). The angular velocity (ω_{crank}) and angular acceleration (α_{crank}) of the crank, the angle (ϕ) along with the lengths (L_{AB}) and (L_{BC}) would be known, and the angle (β), the angular velocity (ω_{rod}), and the velocity of the slider (v_{slider}) would have already been found from the velocity analysis.

Solving for the angular acceleration (α_{rod}) in Eq. (10.21) gives

$$\alpha_{\text{rod}} = \frac{L_{AB}}{L_{BC}} \left(\frac{\omega_{\text{crank}}^2 \cos \phi + \alpha_{\text{crank}} \sin \phi}{\cos \beta} \right) - \omega_{\text{rod}}^2 \tan \beta \quad (10.22)$$

Substituting the angular acceleration (α_{rod}) from Eq. (10.22) to Eq. (10.20) and simplifying (algebra steps omitted) gives the acceleration of the slider (a_{slider}) as

$$a_{\text{slider}} = L_{AB} \left[\omega_{\text{crank}}^2 (\sin \phi - \cos \phi \tan \beta) - \alpha_{\text{crank}} (\cos \phi + \sin \phi \tan \beta) \right] + L_{BC} \omega_{\text{rod}}^2 (\cos \beta + \tan \beta \sin \beta) \quad (10.23)$$

Consider the following example as a continuation of Example 1, where the angle (β) has been found from Eq. (10.12), the angular velocity of the connecting rod (ω_{rod}) found from Eq. (10.10), and the velocity of the slider (v_{slider}) found from Eq. (10.11).

U.S. Customary	SI/Metric
<p>Example 2. Using the angle (β), the angular velocity (ω_{rod}), and the velocity (v_{slider}) found in Example 1, determine the angular acceleration (α_{rod}) and the acceleration of the slider (a_{slider}), where</p>	<p>Example 2. Using the angle (β), the angular velocity (ω_{rod}), and the velocity (v_{slider}) found in Example 1, determine the angular acceleration (α_{rod}) and the acceleration of the slider (a_{slider}), where</p>
$\omega_{\text{crank}} = 2,000 \text{ rpm} = 209 \text{ rad/s}$	$\omega_{\text{crank}} = 2,000 \text{ rpm} = 209 \text{ rad/s}$
$\alpha_{\text{crank}} = 0 \text{ } (\omega_{\text{crank}} = \text{constant})$	$\alpha_{\text{crank}} = 0 \text{ } (\omega_{\text{crank}} = \text{constant})$
$\phi = 50^\circ$	$\phi = 50^\circ$
$L_{AB} = 3 \text{ in}$	$L_{AB} = 7.5 \text{ cm}$
$L_{BC} = 8 \text{ in}$	$L_{BC} = 20 \text{ cm}$
<p>and determined from Example 1:</p>	<p>and determined from Example 1:</p>
$\beta = 14^\circ$	$\beta = 14^\circ$
$\omega_{\text{rod}} = 592 \text{ rpm} = 62 \text{ rad/s}$	$\omega_{\text{rod}} = 592 \text{ rpm} = 62 \text{ rad/s}$
$v_{\text{slider}} = 523 \text{ in/s} = 43.6 \text{ ft/s}$	$v_{\text{slider}} = 1,307 \text{ cm/s} = 13.1 \text{ m/s}$
<p>solution</p>	<p>solution</p>
<p><i>Step 1.</i> Using the given angular velocity (ω_{crank}), angular acceleration (α_{crank}), the angle (ϕ), the lengths (L_{AB}) and (L_{BC}), the angle (β), and angular velocity (ω_{rod}), calculate the angular acceleration (α_{rod}) from Eq. (10.22) as</p>	<p><i>Step 1.</i> Using the given angular velocity (ω_{crank}), angular acceleration (α_{crank}), the angle (ϕ), the lengths (L_{AB}) and (L_{BC}), the angle (β), and angular velocity (ω_{rod}), calculate the angular acceleration (α_{rod}) from Eq. (10.22) as</p>
$\begin{aligned} \alpha_{\text{rod}} &= \frac{L_{AB}}{L_{BC}} \left(\frac{\omega_{\text{crank}}^2 \cos \phi + \alpha_{\text{crank}} \sin \phi}{\cos \beta} \right) \\ &\quad - \omega_{\text{rod}}^2 \tan \beta \\ &= \left(\frac{3 \text{ in}}{8 \text{ in}} \right) \times \\ &\quad \left(\frac{\left(209 \frac{\text{rad}}{\text{s}} \right)^2 \cos 50^\circ + (0) \sin 50^\circ}{\cos 14^\circ} \right) \\ &\quad - \left(62 \frac{\text{rad}}{\text{s}} \right)^2 \tan 14^\circ \\ &= (0.375) \left(\frac{28,078 \text{ rad/s}^2}{0.9703} \right) \\ &\quad - \left(3,844 \frac{\text{rad}}{\text{s}^2} \right) (0.249) \\ &= \left(10,851 \frac{\text{rad}}{\text{s}^2} \right) - \left(958 \frac{\text{rad}}{\text{s}^2} \right) \\ &= 9,893 \frac{\text{rad}}{\text{s}^2} \times \frac{1 \text{ rev}}{2\pi \text{ rad}} \times \frac{60 \text{ s}}{1 \text{ min}} \\ &= 94,471 \frac{\text{rpm}}{\text{s}} \end{aligned}$	$\begin{aligned} \alpha_{\text{rod}} &= \frac{L_{AB}}{L_{BC}} \left(\frac{\omega_{\text{crank}}^2 \cos \phi + \alpha_{\text{crank}} \sin \phi}{\cos \beta} \right) \\ &\quad - \omega_{\text{rod}}^2 \tan \beta \\ &= \left(\frac{7.5 \text{ cm}}{20 \text{ cm}} \right) \times \\ &\quad \left(\frac{\left(209 \frac{\text{rad}}{\text{s}} \right)^2 \cos 50^\circ + (0) \sin 50^\circ}{\cos 14^\circ} \right) \\ &\quad - \left(62 \frac{\text{rad}}{\text{s}} \right)^2 \tan 14^\circ \\ &= (0.375) \left(\frac{28,078 \text{ rad/s}^2}{0.9703} \right) \\ &\quad - \left(3,844 \frac{\text{rad}}{\text{s}^2} \right) (0.249) \\ &= \left(10,851 \frac{\text{rad}}{\text{s}^2} \right) - \left(958 \frac{\text{rad}}{\text{s}^2} \right) \\ &= 9,893 \frac{\text{rad}}{\text{s}^2} \times \frac{1 \text{ rev}}{2\pi \text{ rad}} \times \frac{60 \text{ s}}{1 \text{ min}} \\ &= 94,471 \frac{\text{rpm}}{\text{s}} \end{aligned}$

U.S. Customary	SI/Metric
<p><i>Step 2.</i> Using the given angular velocity (ω_{crank}), angular acceleration (α_{crank}), the angle (ϕ), the lengths (L_{AB}) and (L_{BC}), the angle (β), and angular velocity (ω_{rod}), calculate the slider acceleration (a_{slider}) using Eq. (10.23) as</p> $ \begin{aligned} a_{\text{slider}} &= L_{AB} \left[\begin{array}{l} \omega_{\text{crank}}^2 (\sin \phi - \cos \phi \tan \beta) \\ -\alpha_{\text{crank}} (\cos \phi + \sin \phi \tan \beta) \end{array} \right] \\ &\quad + L_{BC} \omega_{\text{rod}}^2 (\cos \beta + \tan \beta \sin \beta) \\ &= L_{AB} \left[\begin{array}{l} \omega_{\text{crank}}^2 (\sin \phi - \cos \phi \tan \beta) \\ -\alpha_{\text{crank}} (\cos \phi + \sin \phi \tan \beta) \end{array} \right] \\ &\quad + L_{BC} \omega_{\text{rod}}^2 (\cos \beta + \tan \beta \sin \beta) \\ &= (3 \text{ in}) \\ &\quad \times \left[\begin{array}{l} \left(209 \frac{\text{rad}}{\text{s}} \right)^2 \\ \times (\sin 50^\circ - \cos 50^\circ \tan 14^\circ) \\ - (0) \\ \times (\cos 50^\circ + \sin 50^\circ \tan 14^\circ) \end{array} \right] \\ &\quad + (8 \text{ in}) \left(62 \frac{\text{rad}}{\text{s}} \right)^2 \\ &\quad \times (\cos 14^\circ + \tan 14^\circ \sin 14^\circ) \\ &= (3 \text{ in}) \left(43,681 \frac{\text{rad}}{\text{s}^2} \right) (0.606) \\ &\quad + (8 \text{ in}) \left(3,844 \frac{\text{rad}}{\text{s}^2} \right) (1.031) \\ &= \left(79,383 \frac{\text{in}}{\text{s}^2} \right) + \left(31,693 \frac{\text{in}}{\text{s}^2} \right) \\ &= 111,076 \frac{\text{in}}{\text{s}^2} = 9,256 \frac{\text{ft}}{\text{s}^2} \\ &= 287 g's \end{aligned} $	<p><i>Step 2.</i> Using the given angular velocity (ω_{crank}), angular acceleration (α_{crank}), the angle (ϕ), the lengths (L_{AB}) and (L_{BC}), the angle (β), and angular velocity (ω_{rod}), calculate the slider acceleration (a_{slider}) using Eq. (10.23) as</p> $ \begin{aligned} a_{\text{slider}} &= L_{AB} \left[\begin{array}{l} \omega_{\text{crank}}^2 (\sin \phi - \cos \phi \tan \beta) \\ -\alpha_{\text{crank}} (\cos \phi + \sin \phi \tan \beta) \end{array} \right] \\ &\quad + L_{BC} \omega_{\text{rod}}^2 (\cos \beta + \tan \beta \sin \beta) \\ &= L_{AB} \left[\begin{array}{l} \omega_{\text{crank}}^2 (\sin \phi - \cos \phi \tan \beta) \\ -\alpha_{\text{crank}} (\cos \phi + \sin \phi \tan \beta) \end{array} \right] \\ &\quad + L_{BC} \omega_{\text{rod}}^2 (\cos \beta + \tan \beta \sin \beta) \\ &= (7.5 \text{ cm}) \\ &\quad \times \left[\begin{array}{l} \left(209 \frac{\text{rad}}{\text{s}} \right)^2 \\ \times (\sin 50^\circ - \cos 50^\circ \tan 14^\circ) \\ - (0) \\ \times (\cos 50^\circ + \sin 50^\circ \tan 14^\circ) \end{array} \right] \\ &\quad + (20 \text{ cm}) \left(62 \frac{\text{rad}}{\text{s}} \right)^2 \\ &\quad \times (\cos 14^\circ + \tan 14^\circ \sin 14^\circ) \\ &= (7.5 \text{ cm}) \left(43,681 \frac{\text{rad}}{\text{s}^2} \right) (0.606) \\ &\quad + (20 \text{ cm}) \left(3,844 \frac{\text{rad}}{\text{s}^2} \right) (1.031) \\ &= \left(198,458 \frac{\text{cm}}{\text{s}^2} \right) + \left(79,234 \frac{\text{cm}}{\text{s}^2} \right) \\ &= 277,692 \frac{\text{cm}}{\text{s}^2} = 2,777 \frac{\text{m}}{\text{s}^2} \\ &= 283 g's \end{aligned} $

Note the very high *g force* on the slider. Also, like for Example 1, as the values for both the angular acceleration (α_{rod}) and the acceleration of the slider (a_{slider}) are positive, their directions are as shown in Fig. 10.8. If either had turned out negative, then their direction would be opposite to that shown in Fig. 10.8.

10.2.3 Cyclic Motion

In the previous discussion and calculations, a particular orientation of the slider-crank linkage was considered. As mentioned, the unknown velocities and accelerations could only be determined when a particular crank angle (ϕ) was specified, along with the other typical given information. However, it is important to the machine designer to understand the motion of a linkage as it moves through a complete cycle.

For the slider-crank linkage shown in Fig. 10.13, the crank angle (ϕ) is zero.

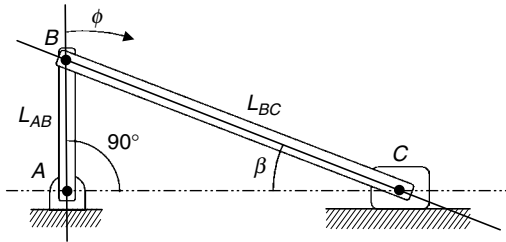

FIGURE 10.13 Slider-crank linkage at $\phi = 0^\circ$.

From Eq. (10.12) the angle (β) becomes

$$\begin{aligned} \sin \beta|_{\phi=0^\circ} &= \left(\frac{L_{AB}}{L_{BC}} \right) \sin (90^\circ - 0^\circ) = \left(\frac{L_{AB}}{L_{BC}} \right) \sin 90^\circ \\ &= \frac{L_{AB}}{L_{BC}} \end{aligned} \quad (10.24)$$

and from Eq. (10.10) the angular velocity of the connecting rod (ω_{rod}) becomes

$$\omega_{rod}|_{\phi=0^\circ} = \left(\frac{L_{AB}}{L_{BC}} \right) \left(\frac{\sin 0^\circ}{\cos \beta} \right) \omega_{crank} = 0 \quad (10.25)$$

and from Eq. (10.11) the velocity of the slider (v_{slider}) becomes

$$\begin{aligned} v_{slider}|_{\phi=0^\circ} &= (L_{AB} \omega_{crank})(\cos 0^\circ + \sin 0^\circ \tan \beta) \\ &= L_{AB} \omega_{crank} \end{aligned} \quad (10.26)$$

and from Eq. (10.22) the angular acceleration of the connecting rod (α_{rod}) becomes

$$\begin{aligned} \alpha_{rod}|_{\phi=0^\circ} &= \frac{L_{AB}}{L_{BC}} \left(\frac{\omega_{crank}^2 \cos 0^\circ + \alpha_{crank} \sin 0^\circ}{\cos \beta} \right) - \omega_{rod}^2|_{\phi=0^\circ} \tan \beta \\ &= \frac{L_{AB}}{L_{BC}} \left(\frac{\omega_{crank}^2}{\cos \beta} \right) - (0)^2 \tan \beta \\ &= \frac{L_{AB}}{L_{BC}} \left(\frac{\omega_{crank}^2}{\cos \beta} \right) \end{aligned} \quad (10.27)$$

and from Eq. (10.23) the acceleration of the slider (a_{slider}) becomes

$$\begin{aligned} a_{slider}|_{\phi=0^\circ} &= L_{AB} [\omega_{crank}^2 (\sin 0^\circ - \cos 0^\circ \tan \beta) - \alpha_{crank} (\cos 0^\circ + \sin 0^\circ \tan \beta)] \\ &\quad + L_{BC} \omega_{rod}^2|_{\phi=0^\circ} (\cos \beta + \tan \beta \sin \beta) \\ &= L_{AB} [-\omega_{crank}^2 \tan \beta - \alpha_{crank}] \\ &\quad + L_{BC} (0)^2 (\cos \beta + \tan \beta \sin \beta) \\ &= -L_{AB} [\omega_{crank}^2 \tan \beta + \alpha_{crank}] \end{aligned} \quad (10.28)$$

Therefore, for crank angle (ϕ) equal to 0° , the angular velocity of the connecting rod (ω_{rod}) is also zero, the velocity of the slider (v_{slider}) is a maximum to the right, the angular acceleration of the connecting rod (α_{rod}) is a maximum counterclockwise (CCW), and the acceleration of the slider (a_{slider}) is a maximum to the right.

For the slider-crank linkage shown in Fig. 10.14, the crank angle (ϕ) is 90° .

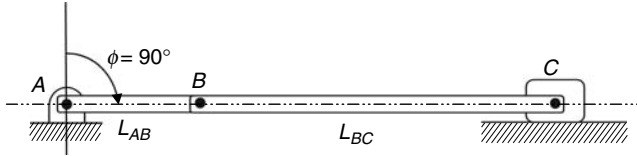

FIGURE 10.14 Slider-crank linkage at $\phi = 90^\circ$.

It is obvious from the geometry in Fig. 10.14 that the angle (β) is zero.

From Eq. (10.10) the angular velocity of the connecting rod (ω_{rod}) becomes

$$\begin{aligned} \omega_{rod}|_{\phi=90^\circ} &= \left(\frac{L_{AB}}{L_{BC}} \right) \left(\frac{\sin 90^\circ}{\cos 0^\circ} \right) \omega_{crank} \\ &= \frac{L_{AB}}{L_{BC}} \omega_{crank} \end{aligned} \quad (10.29)$$

and from Eq. (10.11) the velocity of the slider (v_{slider}) becomes

$$v_{slider}|_{\phi=90^\circ} = (L_{AB} \omega_{crank})(\cos 90^\circ + \sin 90^\circ \tan 0^\circ) = 0 \quad (10.30)$$

and from Eq. (10.22) the angular acceleration of the connecting rod (α_{rod}) becomes

$$\begin{aligned} \alpha_{rod}|_{\phi=90^\circ} &= \frac{L_{AB}}{L_{BC}} \left(\frac{\omega_{crank}^2 \cos 90^\circ + \alpha_{crank} \sin 90^\circ}{\cos 0^\circ} \right) - \omega_{rod}^2|_{\phi=90^\circ} \tan 0^\circ \\ &= \frac{L_{AB}}{L_{BC}} \alpha_{crank} \end{aligned} \quad (10.31)$$

and from Eq. (10.23) the acceleration of the slider (a_{slider}) becomes

$$\begin{aligned} a_{slider}|_{\phi=90^\circ} &= L_{AB} [\omega_{crank}^2 (\sin 90^\circ - \cos 90^\circ \tan 0^\circ) - \alpha_{crank} (\cos 90^\circ + \sin 90^\circ \tan 0^\circ)] \\ &\quad + L_{BC} \omega_{rod}^2|_{\phi=90^\circ} (\cos 0^\circ + \tan 0^\circ \sin 0^\circ) \\ &= L_{AB} \omega_{crank}^2 + L_{BC} \left(\frac{L_{AB}}{L_{BC}} \omega_{crank} \right)^2 \\ &= L_{AB} \omega_{crank}^2 \left(1 + \frac{L_{AB}}{L_{BC}} \right) \end{aligned} \quad (10.32)$$

Therefore, for a crank angle (ϕ) equal to 90° , the angular velocity of the connecting rod (ω_{rod}) is a maximum, the velocity of the slider (v_{slider}) is zero, the angular acceleration of the connecting rod (α_{rod}) is a positive value counterclockwise (CCW), and the acceleration of the slider (a_{slider}) is a maximum to the left. Note that if the angular velocity of the crank is constant, meaning the angular acceleration is zero, then for this crank angle the angular acceleration of the connecting rod will also be zero.

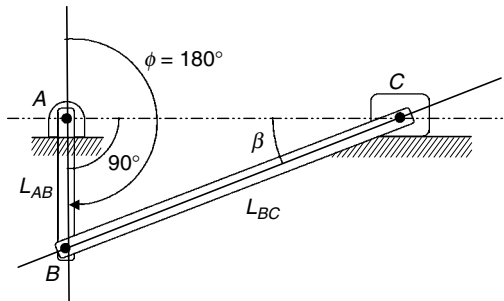

FIGURE 10.15 Slider-crank linkage at $\phi = 180^\circ$.

By analogy with the orientation in Fig. 10.13, if the crank angle is 180° as shown in Fig. 10.15, then the angular velocity of the connecting rod (ω_{rod}) will be zero, the velocity of the slider (v_{slider}) will be maximum, but to the left, the angular acceleration of the connecting rod (α_{rod}) will be maximum, but clockwise (CW), and the acceleration of the slider (a_{slider}) will be maximum, but to the left.

Similarly, by analogy with the orientation in Fig. 10.14, if the crank angle is 270° as shown in Fig. 10.16, then the angular velocity of the connecting rod (ω_{rod}) is maximum, the velocity of the slider (v_{slider}) is zero, the angular acceleration of the connecting rod (α_{rod}) is negative, so it is clockwise (CW), and the acceleration of the slider (a_{slider}) is maximum, except to the right. Again, if the angular velocity of the crank is constant, meaning the angular acceleration is zero, then for this crank angle the angular acceleration of the connecting rod will also be zero.

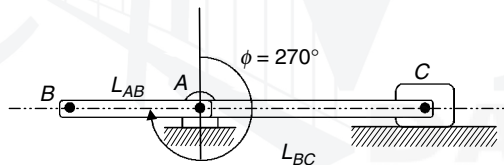

FIGURE 10.16 Slider-crank linkage at $\phi = 270^\circ$.

This completes the discussion on the motion of the slider-crank linkage. Most of the other linkages can be understood through the same process, though it is tedious. However, there is a great feeling of accomplishment when the motion of a linkage of interest is understood to this level of detail.

10.3 GEAR TRAINS

The term *gear train* is usually associated with multiple gears on multiple shafts, though a single gear on one shaft that is in contact with another single gear on another shaft would qualify as a gear train. The gears in gear trains are typically spur gears, meaning straight teeth, though the discussion that follows would be just as applicable to helical and double helical (herringbone) gears.

There are two main categories of gear trains: spur gear trains and planetary gear trains. Here, the term *spur* refers to the fact that all the shafts in the assembly are assumed to be fixed, whereas *planetary* refers to the fact that some of the gears rotate about their own axis while rotating about another axis in a planetary motion.

One of the primary principles of gear train analysis is that the radius, or diameter, of a gear is directly related to the number of teeth. Therefore, the formulas that will be presented that relate an input angular velocity to an output angular velocity will depend only on the number of teeth of the gears in the gear train assembly.

10.3.1 Spur Gears

The most basic of spur gear trains is shown in Fig. 10.17 where a single spur gear (A) on one fixed shaft drives a single spur gear (B) on another fixed shaft.

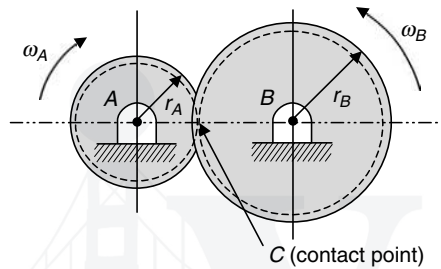

FIGURE 10.17 Basic spur gear train.

If the angular velocity (ω_A) is considered the input, then the output is the angular velocity (ω_B). Note that if the angular velocity (ω_A) is clockwise, then the angular velocity (ω_B) will be counterclockwise. This is due to the fundamental principle that the velocity of point C, the point of contact between the two gears, must have the same magnitude and direction whether determined from gear (A) or gear (B). This means that the relationship in Eq. (10.33) must govern the motion of the two gears.

$$v_C = r_A \omega_A = r_B \omega_B \quad (10.33)$$

Solving for the output angular velocity (ω_B) gives

$$\omega_B = \frac{r_A}{r_B} \omega_A \quad (10.34)$$

As stated earlier, the number of teeth (N) on a spur gear is directly related to its radius, or diameter; therefore, the ratio of the radius (r_A) to (r_B) in Eq. (10.34) must be the same as the ratio of the number of teeth (N_A) on gear (A) to the number of teeth (N_B) on gear (B). Therefore, Eq. (10.34) can be rewritten as

$$\omega_B = \frac{N_A}{N_B} \omega_A \quad (10.35)$$

Based on the relative sizes of gears (A) and (B) shown in Fig. 10.17, the number of teeth on gear (A) is less than the number of teeth on gear (B). Therefore, the output angular velocity (ω_B) will be less than the input angular velocity (ω_A).

U.S. Customary	SI/Metric
<p>Example 1. Determine the output angular velocity for a basic spur gear train as that shown in Fig. 10.17, where</p> <p>$\omega_A = 600$ rpm (input) $N_A = 15$ teeth $N_B = 45$ teeth</p> <p>solution <i>Step 1.</i> Substitute the given input angular velocity (ω_A) and the number of teeth on each gear in Eq. (10.35) to determine the output angular velocity (ω_B) as</p> $\omega_B = \frac{N_A}{N_B} \omega_A = \frac{(15 \text{ teeth})}{(45 \text{ teeth})} (600 \text{ rpm})$ $= \frac{1}{3} (600 \text{ rpm}) = 200 \text{ rpm}$ <p>Remember, the direction of gear (<i>B</i>) will be opposite to the direction of gear (<i>A</i>).</p>	<p>Example 1. Determine the output angular velocity for a basic spur gear train as that shown in Fig. 10.17, where</p> <p>$\omega_A = 600$ rpm (input) $N_A = 15$ teeth $N_B = 45$ teeth</p> <p>solution <i>Step 1.</i> Substitute the given input angular velocity (ω_A) and the number of teeth on each gear in Eq. (10.35) to determine the output angular velocity (ω_B) as</p> $\omega_B = \frac{N_A}{N_B} \omega_A = \frac{(15 \text{ teeth})}{(45 \text{ teeth})} (600 \text{ rpm})$ $= \frac{1}{3} (600 \text{ rpm}) = 200 \text{ rpm}$ <p>Remember, the direction of gear (<i>B</i>) will be opposite to the direction of gear (<i>A</i>).</p>

If a third spur gear (*D*) and fixed shaft is added to the spur gear train in Fig. 10.17, the triple spur gear train shown in Fig. 10.18 results.

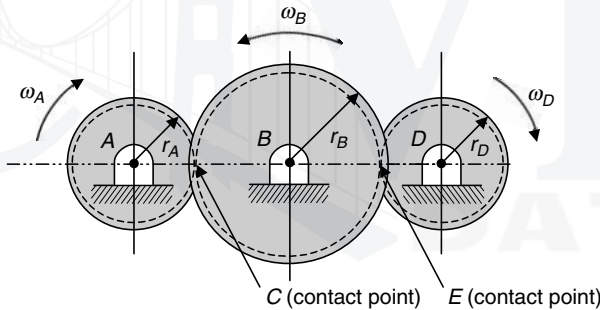

FIGURE 10.18 Triple spur gear train.

If the angular velocity (ω_A) is considered to be the input, then the output is the angular velocity (ω_D). Note that the angular velocity (ω_A) is clockwise, causing the angular velocity (ω_B) to be counterclockwise; however, the angular velocity (ω_D) will be back to clockwise. For this reason, gear (*B*) is sometimes called the *idler* gear, as it causes the output direction to be the same as the input direction. Also, in this arrangement the size of gear (*B*) does not affect the relationship between the input angular velocity and the output angular velocity, as will be seen shortly.

As before, the velocity of point *C*, the point of contact between gears (*A*) and (*B*), must have the same magnitude and direction whether determined from gear (*A*) or gear (*B*). This means that the relationship in Eq. (10.33), which was rewritten as Eq. (10.35), still governs the motion of these two gears.

Similarly, the velocity of point *E*, the point of contact between gears (*B*) and (*D*), must also have the same magnitude and direction whether determined from gear (*B*) or gear (*D*).

This means that the relationship in Eq. (10.36) will govern the motion of these two gears.

$$v_E = r_B \omega_B = r_D \omega_D \quad (10.36)$$

Solving for the angular velocity (ω_D) gives

$$\omega_D = \frac{r_B}{r_D} \omega_B \quad (10.37)$$

As stated earlier, the number of teeth (N) on a spur gear is directly related to its radius, or diameter; therefore, the ratio of the radius (r_B) to (r_D) in Eq. (10.37) must be the same as the ratio of the number of teeth (N_B) on gear (B) to the number of teeth (N_D) on gear (D). Therefore, Eq. (10.37) can be rewritten as

$$\omega_D = \frac{N_B}{N_D} \omega_B \quad (10.38)$$

Substituting the angular velocity (ω_B) from Eq. (10.35) in Eq. (10.38) gives

$$\omega_D = \frac{N_B}{N_D} \omega_B = \frac{N_B}{N_D} \frac{N_A}{N_B} \omega_A = \frac{N_A}{N_D} \omega_A \quad (10.39)$$

where the number of teeth (N_B) on gear (B) cancels. This is why gear (B) is called an idler gear, as its only purpose is to keep the output angular velocity in the same direction as the input angular velocity.

Based on the relative sizes of gears (A), (B), and (D) shown in Fig. 10.18, the number of teeth on gear (A) is less than the number of teeth on gear (D). Therefore, the output angular velocity (ω_D) will be less than the input angular velocity (ω_A) and in the same direction.

U.S. Customary	SI/Metric
<p>Example 2. Determine the output angular velocity for the triple spur gear train as that shown in Fig. 10.18, where</p> <p style="margin-left: 40px;">$\omega_A = 600$ rpm (input) $N_A = 15$ teeth $N_B = 45$ teeth $N_D = 30$ teeth</p> <p>solution</p> <p><i>Step 1.</i> Substitute the given input angular velocity (ω_A) and the number of teeth on gears (A) and (D) in Eq. (10.39) to calculate the output angular velocity (ω_D) as</p> $\omega_D = \frac{N_A}{N_D} \omega_A = \frac{(15 \text{ teeth})}{(30 \text{ teeth})} (600 \text{ rpm})$ $= \frac{1}{2} (600 \text{ rpm}) = 300 \text{ rpm}$ <p>Note that the direction of gear (D) will be the same as the direction of gear (A).</p>	<p>Example 2. Determine the output angular velocity for the triple spur gear train as that shown in Fig. 10.18, where</p> <p style="margin-left: 40px;">$\omega_A = 600$ rpm $N_A = 15$ teeth $N_B = 45$ teeth $N_D = 30$ teeth</p> <p>solution</p> <p><i>Step 1.</i> Substitute the given input angular velocity (ω_A) and the number of teeth on gears (A) and (D) in Eq. (10.39) to calculate the output angular velocity (ω_D) as</p> $\omega_D = \frac{N_A}{N_D} \omega_A = \frac{(15 \text{ teeth})}{(30 \text{ teeth})} (600 \text{ rpm})$ $= \frac{1}{2} (600 \text{ rpm}) = 300 \text{ rpm}$ <p>Note that the direction of gear (D) will be the same as the direction of gear (A).</p>

Any number of spur-type gears on any number of fixed parallel shafts can be approached using this fundamental principle that the velocity of the contact points between any two gears must be the same from each gear's perspective.

10.3.2 Planetary Gears

The most basic of planetary gear trains is shown in Fig. 10.19 where the axis of the single planet gear (*A*) is fixed to one end of the rotating arm (*B*) and is in contact with a fixed internal ring gear (*D*).

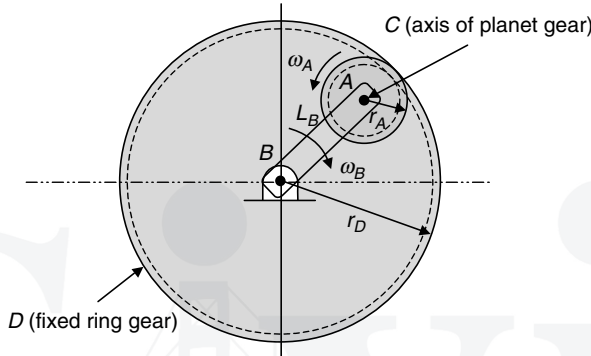

FIGURE 10.19 Basic planetary gear train.

As arm (*B*) rotates about its own fixed axis, the planet gear (*A*) must roll along the inside of the fixed ring gear (*D*). This means the planet gear (*A*) not only rotates about its own axis at the end of arm (*B*) but also rotates about the fixed axis of arm (*B*) at the center of the gear train, meaning gear (*A*) moves in a planetary motion for which this type gear train is named.

If the angular velocity (ω_B) of the arm is considered the input, then the output is the angular velocity of the planet gear (ω_A). If the angular velocity (ω_B) of the arm is clockwise, then the angular velocity (ω_A) of the planet gear will be counterclockwise. This is due to the fundamental principle that the velocity of point *C*, the axis of the planet gear (*A*), must have the same magnitude and direction whether determined from the fixed axis of arm (*B*) or the fixed ring gear (*D*). This means that the relationship in Eq. (10.40) must govern the motion of the arm (*B*) and the planet gear (*A*).

$$v_C = r_A \omega_A = L_B \omega_B \tag{10.40}$$

where (L_B) is the length of arm (*B*).

Solving for the output angular velocity (ω_A) gives

$$\omega_A = \frac{L_B}{r_A} \omega_B \tag{10.41}$$

From the geometry in Fig. 10.19, the length (L_B) of arm (*B*) can be expressed in terms of the radius of the planet gear (*A*) and the radius of the fixed ring gear (*D*) as

$$L_B = r_D - r_A \tag{10.42}$$

Substitute for (L_B) from Eq. (10.42) in Eq. (10.41) to give

$$\omega_A = \frac{r_D - r_A}{r_A} \omega_B = \left(\frac{r_D}{r_A} - 1 \right) \omega_B \tag{10.43}$$

As stated earlier, the number of teeth (N) on a spur gear is directly related to its radius, or diameter; therefore, the ratio of the radius (r_D) to (r_A) in Eq. (10.43) must be the same as the ratio of the number of teeth (N_D) on the fixed ring gear (D) to the number of teeth (N_A) on the planet gear (A). Therefore, Eq. (10.43) can be rewritten as

$$\omega_A = \left(\frac{N_D}{N_A} - 1 \right) \omega_B \quad (10.44)$$

Based on the relative sizes of the planet gear (A) and the ring gear (D) shown in Fig. 10.19, the number of teeth on gear (A) is less than the number of teeth on gear (D). Therefore, the output angular velocity (ω_A) could be greater than the input angular velocity (ω_B) of the arm; however, it is always in the opposite direction.

U.S. Customary	SI/Metric
<p>Example 3. Determine the output angular velocity for the planetary gear train as that shown in Fig. 10.19, where</p> <p>$\omega_B = 1,800$ rpm (input) $N_A = 64$ teeth $N_D = 192$ teeth</p> <p>solution <i>Step 1.</i> Substitute the given input angular velocity (ω_B) and the number of teeth on gears (A) and (D) in Eq. (10.44) to calculate the output angular velocity (ω_A) as</p> $\begin{aligned} \omega_A &= \left(\frac{N_D}{N_A} - 1 \right) \omega_B \\ &= \left(\frac{192 \text{ teeth}}{64 \text{ teeth}} - 1 \right) (1,800 \text{ rpm}) \\ &= (3 - 1)(1,800 \text{ rpm}) \\ &= (2)(1,800 \text{ rpm}) = 3,600 \text{ rpm} \end{aligned}$ <p>There is a 2:1 increase in the angular speed, with the direction of gear (A) opposite to the direction of arm (B).</p>	<p>Example 3: Determine the output angular velocity for the planetary gear train as that shown in Fig. 10.19, where</p> <p>$\omega_B = 1,800$ rpm (input) $N_A = 64$ teeth $N_D = 192$ teeth</p> <p>solution <i>Step 1.</i> Substitute the given input angular velocity (ω_B) and the number of teeth on gears (A) and (D) in Eq. (10.44) to calculate the output angular velocity (ω_A) as</p> $\begin{aligned} \omega_A &= \left(\frac{N_D}{N_A} - 1 \right) \omega_B \\ &= \left(\frac{192 \text{ teeth}}{64 \text{ teeth}} - 1 \right) (1,800 \text{ rpm}) \\ &= (3 - 1)(1,800 \text{ rpm}) \\ &= (2)(1,800 \text{ rpm}) = 3,600 \text{ rpm} \end{aligned}$ <p>There is a 2:1 increase in the angular speed, with the direction of gear (A) opposite to the direction of arm (B).</p>

Suppose another gear is added to the axis of the planet gear (A) and moves with the same angular velocity (ω_A) forming what is called a *compound* gear set. Also, suppose this additional gear is in contact with another gear, called a *sun* gear, mounted on the fixed axis of the rotating arm (B); however, it is free to rotate at its own angular velocity. This new more complex arrangement is shown in Fig. 10.20, where (E) is the additional gear on the axis of the planet gear (A) forming the compound gear set, and (F) is the sun gear. Point G is the point of contact between gears (E) and (F), and must have a velocity that has the same magnitude and direction whether related to gear (E) or gear (F). This is a similar condition already placed on point C , the axis of the compound gear set on the rotating arm (B).

For this configuration, the angular velocity (ω_B) of arm (B) is still the input; however, now the output is the angular velocity (ω_F) of the sun gear (F). Notice that the direction

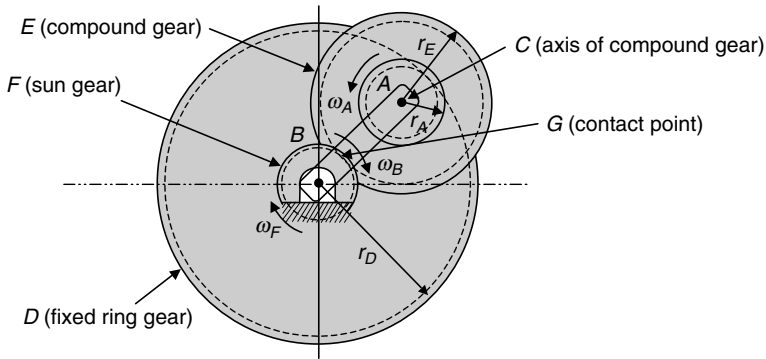

FIGURE 10.20 Complex planetary gear train.

of rotation of the sun gear (F) is the same as the direction of rotation of the arm (B). This is similar to what an idler gear does for a fixed axis spur gear train; however, a planetary gear train is more compact, and that is one of its most important advantages.

As before, arm (B) rotates about its own fixed axis so that the planet gear (A) must roll along the inside of the fixed ring gear (D). As gear (E) moves with gear (A), it must have the same angular velocity (ω_A), given by Eq. (10.44), and have the same direction that is opposite to the direction of the arm (B).

As stated earlier, at the contact point G between compound gear (E) and the sun gear (F), the velocity of point G must be the same velocity whether expressed from gear (E) or gear (F). Therefore, the motion of these two gears must be governed by the expression in Eq. (10.45) as

$$v_G = (r_A + r_E)\omega_E = r_F\omega_F \quad (10.45)$$

where the compound gear (E) appears to be rolling on the inside of the ring gear (D) with a single radius equal to the sum of the radius of gear (A) plus the radius of gear (E).

Solving for the output angular velocity (ω_F) gives

$$\omega_F = \frac{r_A + r_E}{r_F}\omega_E \quad (10.46)$$

where from Fig. 10.20 the directions of (ω_E) and (ω_F) are opposite to each other.

As the number of teeth (N) on a spur gear is directly related to its radius, or diameter, Eq. (10.46) can be rewritten as

$$\omega_F = \frac{N_A + N_E}{N_F}\omega_E \quad (10.47)$$

Also, the angular velocities (ω_A) and (ω_E) of the compound gear set are the same, meaning

$$\omega_E = \omega_A \quad (10.48)$$

Replacing (ω_E) with (ω_A), and substituting for (ω_A) from Eq. (10.44), Eq. (10.47) becomes

$$\begin{aligned} \omega_F &= \frac{N_A + N_E}{N_F}\omega_E = \frac{N_A + N_E}{N_F}\omega_A \\ &= \frac{N_A + N_E}{N_F} \left(\frac{N_D}{N_A} - 1 \right) \omega_B \end{aligned} \quad (10.49)$$

U.S. Customary	SI/Metric
<p>Example 4. Determine the output angular velocity for the planetary gear train as that shown in Fig. 10.20, where</p> <p>$\omega_B = 1,800$ rpm (input) $N_A = 64$ teeth $N_D = 192$ teeth $N_E = 80$ teeth $N_F = 48$ teeth</p> <p>solution <i>Step 1.</i> Substitute the given input angular velocity (ω_B) and the number of teeth on gears (A), (D), (E), and (F) in Eq. (10.49) to calculate the output angular velocity (ω_F) as</p> $\omega_F = \frac{N_A + N_E}{N_F} \left(\frac{N_D}{N_A} - 1 \right) \omega_B$ $= \frac{(64 + 80) \text{ teeth}}{48 \text{ teeth}} \left(\frac{192 \text{ teeth}}{64 \text{ teeth}} - 1 \right)$ $\times (1,800 \text{ rpm})$ $= (3)(3 - 1)(1,800 \text{ rpm})$ $= (6)(1,800 \text{ rpm}) = 10,800 \text{ rpm}$ <p>There is a 6:1 increase in the angular speed, with the direction of gear (F) in the same direction as arm (B).</p>	<p>Example 4. Determine the output angular velocity for the planetary gear train as that shown in Fig. 10.20, where</p> <p>$\omega_B = 1,800$ rpm (input) $N_A = 64$ teeth $N_D = 192$ teeth $N_E = 80$ teeth $N_F = 48$ teeth</p> <p>solution <i>Step 1.</i> Substitute the given input angular velocity (ω_B) and the number of teeth on gears (A), (D), (E), and (F) in Eq. (10.49) to calculate the output angular velocity (ω_F) as</p> $\omega_F = \frac{N_A + N_E}{N_F} \left(\frac{N_D}{N_A} - 1 \right) \omega_B$ $= \frac{(64 + 80) \text{ teeth}}{48 \text{ teeth}} \left(\frac{192 \text{ teeth}}{64 \text{ teeth}} - 1 \right)$ $\times (1,800 \text{ rpm})$ $= (3)(3 - 1)(1,800 \text{ rpm})$ $= (6)(1,800 \text{ rpm}) = 10,800 \text{ rpm}$ <p>There is a 6:1 increase in the angular speed, with the direction of gear (F) in the same direction as arm (B).</p>

Realize that to achieve the same input to output ratio 6:1 using a spur gear train, the input gear would have to be six times the diameter, or number of teeth, as the output gear. This would not be a very compact gear train arrangement. Again, this is the advantage of a planetary gear train; however, its disadvantage is that it is more complex to manufacture and maintain the close tolerances necessary for its efficient operation.

One last comment on planetary gear trains. To distribute the loading on the ring gear, many times there are multiple compound gears driving a single sun gear, resulting in a rotating arm with multiple spokes. However, this would not change the input to output ratio of the angular velocities; therefore, the principles and formulas presented in this section are valid for even the most complex configuration of gears and rotating arms.

10.4 WHEELS AND PULLEYS

While the discussion in the previous section involved the motion of gears, which were treated as both rotating and rolling wheels, here the motion of wheels rolling freely on a flat rough surface will be discussed. The velocity at a variety of important locations around the rolling wheel will be presented.

Pulleys can also rotate and roll. The motion of simple to complex pulley arrangements will be discussed, building on the discussions of both gears trains and rolling wheels.

10.4.1 Rolling Wheels

One of the most basic of motions in the study of machines is the velocity of a rolling wheel on a flat surface, shown in Fig. 10.21.

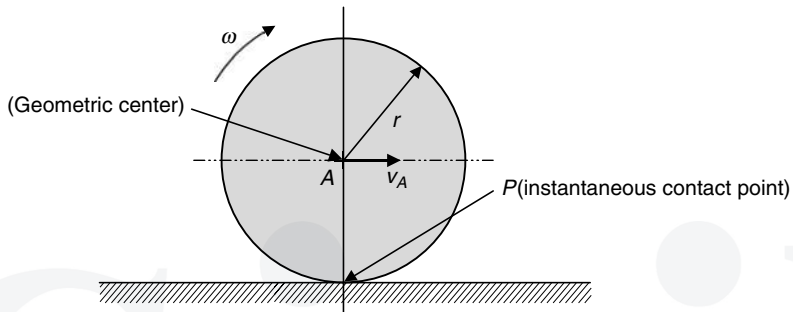

FIGURE 10.21 Velocity of a rolling wheel on a flat surface.

If the wheel rolls without slipping, then the velocity at point P is zero, and the velocity of the geometric center of the wheel, point A , will be given by the expression

$$v_A = r\omega \quad (10.50)$$

where (r) is the radius of the wheel and (ω) is the angular velocity of the wheel. For the clockwise angular rotation (ω) shown in Fig. 10.21, the velocity (v_A) of the center of the wheel will be to the right as shown.

If the velocity (v_A) is known, which many times it is, then the angular velocity (ω) can be found by rearranging Eq. (10.50) to give

$$\omega = \frac{v_A}{r} \quad (10.51)$$

U.S. Customary	SI/Metric
<p>Example 1. Determine the angular velocity of a rolling wheel like that shown in Fig. 10.21, where</p> <p>$v_A = 60 \text{ mph}$ $r = 8 \text{ in} = 0.67 \text{ ft}$</p> <p>solution <i>Step 1.</i> Convert the given velocity of the center of the rolling wheel to (ft/s) as</p> $v_A = 60 \frac{\text{mi}}{\text{h}} \times \frac{5,280 \text{ ft}}{\text{mi}} \times \frac{1 \text{ h}}{3,600 \text{ s}}$ $= 88 \text{ ft/s}$	<p>Example 1. Determine the angular velocity of a rolling wheel like that shown in Fig. 10.21, where</p> <p>$v_A = 96.5 \text{ kph}$ $r = 20 \text{ cm} = 0.2 \text{ m}$</p> <p>solution <i>Step 1.</i> Convert the given velocity of the center of the rolling wheel to (m/s) as</p> $v_A = 96.5 \frac{\text{km}}{\text{h}} \times \frac{1,000 \text{ m}}{\text{km}} \times \frac{1 \text{ h}}{3,600 \text{ s}}$ $= 26.8 \text{ m/s}$

U.S. Customary	SI/Metric
<p><i>Step 2.</i> Substitute the velocity (v_A) found in step 1 and the given radius (r) of the rolling wheel in Eq. (10.51) to determine the angular velocity (ω) as</p> $\omega = \frac{v_A}{\text{rev}} = \frac{88 \text{ ft/s}}{0.67 \text{ ft}}$ $= 132 \frac{\text{rad}}{\text{s}} \times \frac{1 \text{ rev}}{2\pi \text{ rad}} \times \frac{60 \text{ s}}{1 \text{ min}}$ $= 1,260 \text{ rpm}$	<p><i>Step 2.</i> Substitute the velocity (v_A) found in step 1 and the given radius (r) of the rolling wheel in Eq. (10.51) to determine the angular velocity (ω) as</p> $\omega = \frac{v_A}{\text{rev}} = \frac{26.8 \text{ m/s}}{0.2 \text{ m}}$ $= 134 \frac{\text{rad}}{\text{s}} \times \frac{1 \text{ rev}}{2\pi \text{ rad}} \times \frac{60 \text{ s}}{1 \text{ min}}$ $= 1,280 \text{ rpm}$

From the principles of relative motion, the velocity of any other point on the wheel will be the velocity (v_A), which has a magnitude of ($r\omega$), plus an additional velocity equal to ($r\omega$) except directed perpendicular to the line connecting the point with the center of the wheel and is in the direction of the angular velocity (ω). Fig. 10.22 shows the velocities of three special points B , C , and D , and why the velocity of point P is in fact zero.

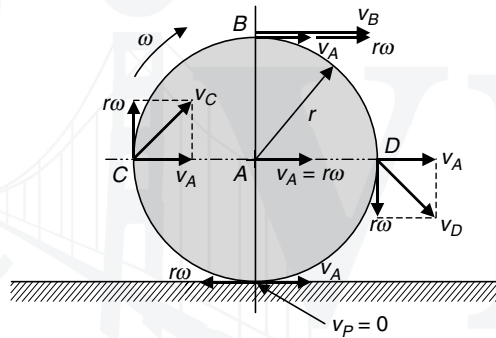

FIGURE 10.22 Velocity of special points on a rolling wheel.

Therefore, the velocity at the top of the wheel, point B , has a magnitude

$$v_B = v_A + r\omega = v_A + v_A = 2v_A \quad (10.52)$$

which is twice the velocity of the center of the wheel (v_A) and directed to the right as shown. Also, the velocity of the instantaneous contact point P is zero as the velocity (v_A) to the right is canceled by the velocity ($r\omega$) to the left.

The velocity (v_C) at the left side of the wheel, point C , has a magnitude given by the pythagorean theorem as

$$v_C = \sqrt{(v_A)^2 + (r\omega)^2} = \sqrt{(v_A)^2 + (v_A)^2} = \sqrt{2}v_A \quad (10.53)$$

and directed upward at 45° relative to the horizontal as shown.

Similarly, the velocity (v_D) at the right side of the wheel, point D , has a magnitude given by the pythagorean theorem as

$$v_D = \sqrt{(v_A)^2 + (r\omega)^2} = \sqrt{(v_A)^2 + (v_A)^2} = \sqrt{2}v_A \quad (10.54)$$

and directed downward at 45° relative to the horizontal as shown.

Fig. 10.23 shows the velocities of four additional points E , F , G , and H .

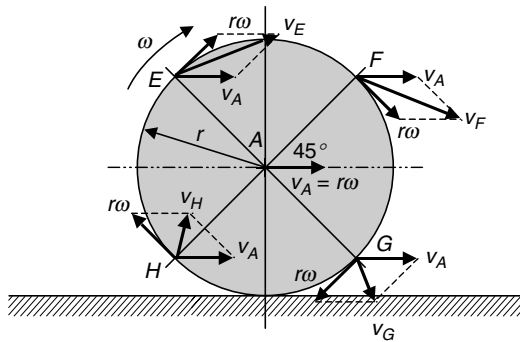

FIGURE 10.23 Velocity of four additional points on a rolling wheel.

Choosing point F in Fig. 10.23, its velocity has a magnitude given by the Pythagorean theorem as

$$\begin{aligned}
 v_F &= \sqrt{(v_A + r\omega \cos 45^\circ)^2 + (-r\omega \sin 45^\circ)^2} \\
 &= \sqrt{(v_A + v_A \cos 45^\circ)^2 + (-v_A \sin 45^\circ)^2} \\
 &= \sqrt{v_A^2[(1 + \cos 45^\circ)^2 + (-\sin 45^\circ)^2]} = \sqrt{v_A^2[3.414]} \\
 &= (1.85)v_A
 \end{aligned}
 \tag{10.55}$$

and its direction is downward from the horizontal, a negative angle (θ) given by the expression

$$\begin{aligned}
 \tan \theta &= \frac{-r\omega \sin 45^\circ}{v_A + r\omega \cos 45^\circ} = \frac{-v_A \sin 45^\circ}{v_A + v_A \cos 45^\circ} = \frac{-\sin 45^\circ}{1 + \cos 45^\circ} = -0.414 \\
 \theta &= -22.5^\circ
 \end{aligned}
 \tag{10.56}$$

The magnitude of the other three velocities is the same as that given by Eq. (10.55); however, each velocity is at a different angle relative to the horizontal.

U.S. Customary	SI/Metric
<p>Example 2. Determine the velocity, both its magnitude and direction, of point H on the rolling wheel shown in Fig. 10.23, where</p> <p style="text-align: center;">$v_A = 60 \text{ mph} = 88 \text{ ft/s}$</p> <p>solution</p> <p><i>Step 1.</i> Substitute the given velocity (v_A) of the center of the wheel in Eq. (10.55) to determine the magnitude of the velocity (v_H) as</p> <p style="text-align: center;"> $v_H = (1.85)v_A = (1.85)(88 \text{ ft/s})$ $= 162.8 \text{ ft/s}$ </p>	<p>Example 2. Determine the velocity, both its magnitude and direction, of point H on the rolling wheel shown in Fig. 10.23, where</p> <p style="text-align: center;">$v_A = 96.5 \text{ kph} = 26.8 \text{ m/s}$</p> <p>solution</p> <p><i>Step 1.</i> Substitute the given velocity (v_A) of the center of the wheel in Eq. (10.55) to determine the magnitude of the velocity (v_H) as</p> <p style="text-align: center;"> $v_H = (1.85)v_A = (1.85)(26.8 \text{ m/s})$ $= 49.6 \text{ m/s}$ </p>

U.S. Customary	SI/Metric
<p><i>Step 2.</i> Substitute the given velocity (v_A) of the center of the wheel in Eq. (10.56) to determine the angle (θ) as</p> $\begin{aligned} \tan \theta &= \frac{r\omega \sin 45^\circ}{v_A - r\omega \cos 45^\circ} \\ &= \frac{v_A \sin 45^\circ}{v_A - v_A \cos 45^\circ} \\ &= \frac{\sin 45^\circ}{1 - \cos 45^\circ} = 2.414 \\ \theta &= 67.5^\circ \end{aligned}$ <p>The velocity (v_H) is to the right at the magnitude calculated in step 1 at the angle (θ) calculated in step 2 above the horizontal.</p>	<p><i>Step 2.</i> Substitute the given velocity (v_A) of the center of the wheel in Eq. (10.56) to determine the angle (θ) as</p> $\begin{aligned} \tan \theta &= \frac{r\omega \sin 45^\circ}{v_A - r\omega \cos 45^\circ} \\ &= \frac{v_A \sin 45^\circ}{v_A - v_A \cos 45^\circ} \\ &= \frac{\sin 45^\circ}{1 - \cos 45^\circ} = 2.414 \\ \theta &= 67.5^\circ \end{aligned}$ <p>The velocity (v_H) is to the right at the magnitude calculated in step 1 at the angle (θ) calculated in step 2 above the horizontal.</p>

10.4.2 Pulley Systems

The simplest pulley system is shown in Fig. 10.24, where a single pulley transfers a downward force (P) into an upward force (P) to lift the load (W).

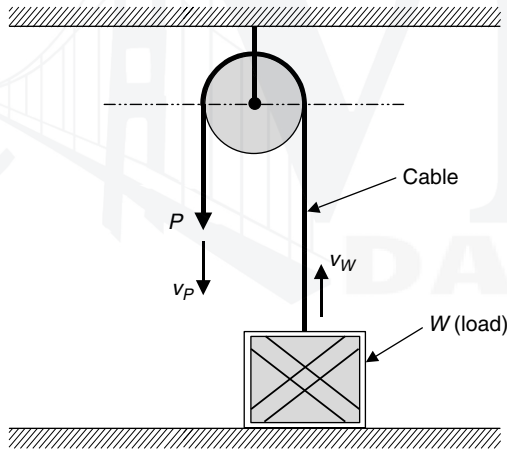

FIGURE 10.24 Simplest pulley system.

The downward velocity (v_P) of the force (P) is equal to the upward velocity (v_W) of the load (W) given by Eq. (10.57) as

$$v_W = v_P \tag{10.57}$$

Therefore, for this simplest of pulley systems there is no mechanical advantage, meaning the force (P) is the same magnitude as the load (W), and the velocities (v_P) and (v_W) are equal.

Consider the two pulley system shown in Fig. 10.25 where the upper pulley (1) is twice the diameter of the lower pulley (2).

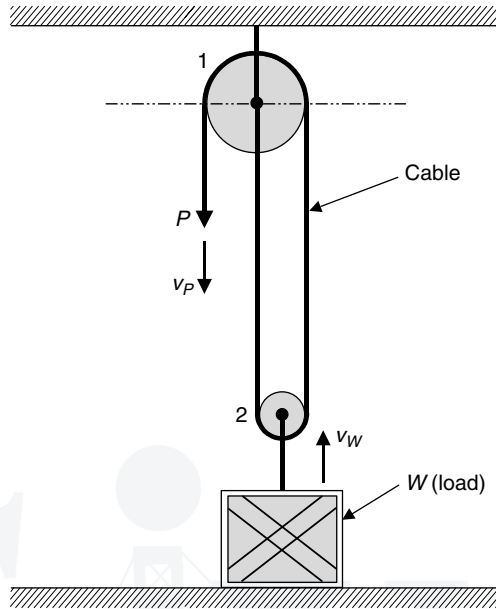

FIGURE 10.25 Two pulley system.

As the tension in the cable on each side of the lower pulley (2) is equal to the force (P), the mechanical advantage is (2:1), meaning the force (P) is half the magnitude of the load (W). Also, as the force (P) moves downward the lower pulley (2) rolls like a wheel up the cable that is attached to the center of the upper pulley (1). From the last section on rolling wheels, the velocity of the center of a wheel is half the velocity at a point at the top of the wheel. Therefore, the velocity (v_W) of the load (W), which is equal to the velocity of the center of the lower pulley (2), is half the velocity (v_P) of the force (P) and given by Eq. (10.58) as

$$v_W = \frac{1}{2}v_P \quad (10.58)$$

Finally, consider the complex pulley system shown in Fig. 10.26 where pulleys (3) and (4) are connected to pulleys (1) and (2), respectively, by rigid links. Pulleys (1) and (2) have the same diameter, and pulleys (3) and (4) have the same diameter.

As there is only one active cable, the mechanical advantage is (4:1), meaning the force (P) is one-fourth the magnitude of the load (W). Also, depending on the relative diameters of the large pulleys (1) and (2) as compared to the small pulleys (3) and (4), the upward velocity (v_W) will be some fraction of the velocity (v_P) of the force (P) as it moves downward.

From the configuration of the pulleys in Fig. 10.26, the lower pulley (2) will again roll like a wheel up the cable that passes around pulley (3), even though this cable is not perfectly vertical. As the separation distance between the centers of pulleys (3) and (4) would be much larger than that shown in Fig. 10.26, the angle by which this cable and the cable that passes around pulley (4) and goes up to the center of pulley (3) is off from the vertical will be small.

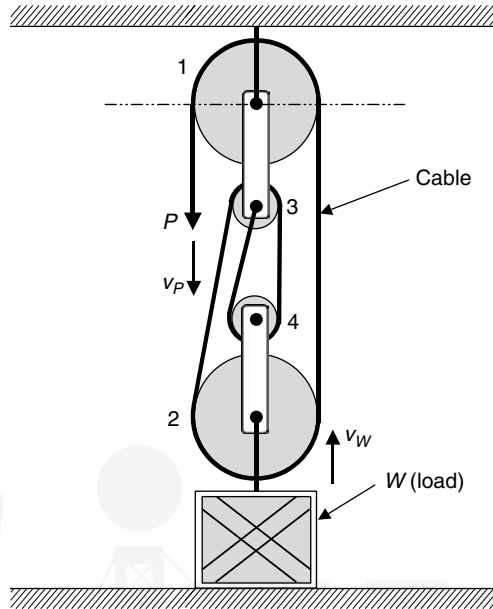

FIGURE 10.26 Complex pulley system.

Therefore, the velocity (v_W) of the load (W), which is equal to the velocity of the center of the lower pulley (2), is the fraction ($1/x$) of the velocity (v_P) of the force (P) and given by Eq. (10.59) as

$$v_W = \frac{1}{x} v_P \quad (10.59)$$

where (x) is determined for specific diameters of all four pulleys and for a particular distance between pulleys (3) and (4).

This completes the chapter on machine motion and thus we come to “The End” of the ten chapters of this first edition of *Marks’ Calculations for Machine Design*. It has been a pleasure uncovering the mystery of the formulas in machine design that are so important to bring about a safe and operationally sound design. Having said so, it must also be mentioned that for you it is just the beginning of a creative odyssey. The machines you would design based on the knowledge gained from this book, and the new ideas, theories, equations, and techniques you would come up with would go to increase the volume of books like this considerably in each subsequent edition. Best wishes for your designs.



This page intentionally left blank.

BIBLIOGRAPHY

- American Institute of Steel Construction (AISC), *Manual of Steel Construction*, 8th ed., American Institute of Steel Construction, Chicago, IL, 1980.
- Design Handbook*, Associated Spring-Barnes Group, Bristol, CT, 1981.
- Walton, C. F. (ed.), *Iron Casting Handbook*, 3d ed., Iron Founder's Society, Rocky River, OH, 1981.
- E. A. Avallone and T. Baumeister, III, Eds. *Marks' Standard Handbook for Mechanical Engineers*, 10th ed., McGraw-Hill, New York, 1996.
- Marin, J., *Mechanical Behavior of Engineering Materials*, Prentice-Hall, Englewood Cliffs, NJ, 1962.
- Shigley, J. E., and C. R. Mischke, *Mechanical Engineering Design*, 6th ed., McGraw-Hill, Boston, MA, 2001.
- Wahl, A. M., *Mechanical Springs*, 2nd ed., McGraw-Hill, New York, 1963.
- Gere, J. M., and S. P. Timoshenko, *Mechanics of Materials*, 4th ed., PWS-Kent Publishing, Boston, MA, 1997.
- American National Standard Institute, *Preferred Limits and Fits for Cylindrical Parts*, ANSI B4.1-1967, Washington, DC (Revised 1999).
- American National Standard Institute, *Preferred Metric Limits and Fits for Cylindrical Parts*, ANSI B4.2-1978, Washington, DC (Revised 1999).
- Shigley, J. E., C. R. Mischke, and T. H. Brown, Jr. (eds.), *Standard Handbook of Machine Design*, 3d ed., McGraw-Hill, New York, 2004.
- Peterson, R. E., *Stress Concentration Factors*, Wiley, New York, 1974.



This page intentionally left blank.

INDEX

- Acceleration analysis, 416–419
- Advanced loadings, 127
- American Welding Society (AWS), 348
- Amplitude stress, 285
- Angle of twist, 19
- Angular rotation, 392
- Area:
 - tensile-stress, 324
- Average stress, 196
- Axial loading, 4, 156, 159, 164, 172
- Axial strain, 5
- Axial stress, 4
 - in cylinders:
 - thin-walled, 129, 191
 - thick-walled, 133–134
 - prismatic, 4
- Beams, 33
 - cantilevered, 33–34, 97
 - double overhanging, 35
 - simply-supported, 33, 35
 - single overhanging, 35
- Beam loadings:
 - concentrated couple, 48, 110
 - concentrated force at free end(s), 73, 86, 98
 - concentrated force at intermediate point, 41, 104
 - concentrated force at midpoint, 36, 159
 - triangular load, 60, 120
 - twin concentrated forces, 67
 - uniform load, 55, 79, 92, 115
- Beam supports:
 - cantilever, 35
 - pin, 34
 - roller, 34
- Bending, 24, 158, 167, 184
- Bergstrasser factor, 370
- Biaxial stress element, 148
- Bolt:
 - length, 323
 - strength, 331
- Bolted connections, 321
- Butt welds, 348
- Cantilevered beams, 33–34, 97, 98, 104, 110, 115, 120
- Change in length:
 - prismatic bar, 8
- Classic mechanism designs, 410
- Coefficient of expansion, 10
- Coefficient of speed fluctuation, 393, 397
- Column buckling, 260
 - Euler formula, 261
 - Parabolic formula, 263
 - Secant formula, 266
 - Short columns, 270
- Column end types, 262
- Combined loadings:
 - dynamic, 311
 - static:
 - axial and bending, 159
 - axial and pressure, 172
 - axial and thermal, 164
 - axial and torsion, 156
 - bending and pressure, 184
 - torsion and bending, 167
 - torsion and pressure, 175
- Complex planetary gear trains, 430
- Complex pulley systems, 437
- Composite flywheels, 401–403
- Compression springs, 380–382
- Concentrated couple loading, 48, 110
- Cone angle in bolted connections, 327
- Contact loading:
 - cylinders in contact, 143
 - spheres in contact, 139

- Contact pressure, maximum:
 - between cylinders, 144
 - between spheres, 140
 - Corrosion effect, 283
 - Coulomb-Mohr theory, 248
 - graphical representation, 248
 - Critical frequency, 383–384
 - Cycle frequency effect, 283
 - Cyclic loading, 276
 - Cyclic motion, 421–424
 - Cylinders:
 - thin-walled, 129
 - thick-walled, 130
 - Design:
 - dynamic, 273
 - static, 233
 - Direct shear loading, 3, 11
 - Disassemblable joint bolt preload, 332
 - Distortion-energy theory, 237
 - graphical representation, 237
 - Double overhanging beams, 35, 86, 92
 - Elastic limit, 6, 14
 - Eccentricity ratio, 267
 - graphical representation, 267
 - Effective diameter, 281
 - Electrolytic plating effect, 283
 - Elongation method for bolt preload, 332
 - Endurance limit, 276
 - Energy, 375–376
 - Extension springs, 379–380
 - hook geometry, 379
 - External load on bolted joints, 332–334
 - Euler formula, 261
 - Factors, Marin equation:
 - load type, 282
 - miscellaneous effects, 282–283
 - size, 280–281
 - surface finish, 280
 - Factors of safety:
 - against bolted joint separation, 335–336
 - dynamic design:
 - fluctuating loading:
 - Gerber theory, 288–289
 - Goodman theory, 288–292
 - Modified Goodman theory, 288–289
 - stress-concentration factor, 304
 - torsional loading, 305
 - static design:
 - brittle materials:
 - Coulomb-Mohr theory, 249
 - Maximum-normal-stress theory, 248
 - Modified Coulomb-Mohr theory, 250
 - ductile materials:
 - Distortion-energy theory, 238
 - Maximum-normal-stress theory, 235
 - Maximum-shear-stress theory, 237
 - yielding of a bolted connection, 339
- Fastener assembly types, 321
- Fatigue, 273
- Fatigue loading of:
 - bolted connections, 337–340
 - helical spring, 385–386
 - welded connections, 365–366
- Fillet weld geometry for:
 - bending, 357
 - torsion, 353
- Fillet welds, 348, 350–358
- Fillet welds treated as lines, 360–363
- Finite life, 276, 277
- First moment of area:
 - definition, 27
 - formula for the maximum value:
 - circular cross section, 31
 - rectangular cross section, 28
- Fit standards, 137
- Fluctuating design criteria, 287
- Flywheels, 388
- Four-bar linkage, 410
- Four-stroke engine, 392
- Fracture point, 6, 14
- Free Body Diagram (FBD) of a helical spring, 368
- Fretting effect, 283
- Frustum in bolted connections, 326–327
- Fundamental loadings, 3
 - summary table of formulas, 153
- Gaskets in bolted connections, 326
- Gear trains, 424
- Geometry of:
 - fillet welds as lines, 361
 - helical springs, 368
 - slider-crank linkage, 414
- Gerber theory, 288–289
- Goodman Diagram for:
 - bolted connections, 338
 - fluctuating torsional loading, 386
 - welded connections, 366
- Goodman theory, 288–289

- Grip, of a bolted connection, 323
- Groove welds, 348
- Helical spring deflection, 371
- Helical springs, 367
- Hole punching, 15
- Hooke's law:
 - axial, 6, 9, 10
 - shear, 14
- Hoop stress in cylinders, 129, 191
- Infinite life, 276
- Instantaneous contact point, 432
- Interface pressure, 135
- Internal combustion engines, 392–394
- Joint contact, 334
- Lap joint, 350
- Lateral strain, 7
- Linkages, 410
- Load factor on bolted connections, 335
- Load type factor for Marin equation, 282
- Loadings:
 - advanced, 127
 - axial, 4, 156, 159, 164
 - bending, 24, 159, 167, 184
 - combined, 153
 - contact, 139
 - direct shear, 11
 - fluctuating, 285
 - fundamental, 3
 - pressure, 127, 172, 175, 184
 - reversed, 274
 - rotational, 147
 - summary table of formulas, 153, 154
 - thermal, 10, 164
 - torsion, 16, 156, 167, 175
 - triangular, 60, 120
 - uniform, 55, 79, 92, 115
- Machine:
 - assembly, 321
 - energy, 367
 - motion, 409
- Marin equation, 279
- Maximum-normal-stress theory:
 - brittle materials, 247
 - graphical representation, 247
 - ductile materials, 234
 - graphical representation, 247
- Maximum-shear-stress theory, 235
 - graphical representation, 236
- Maximum shear stress, 196
- Mean stress, 285
- Mechanical advantage, 436
- Members, in a bolted connection, 326
- Minimum shear stress, 196
- Miscellaneous effects factors for Marin
 - equation, 282–283
- Modified Coulomb-Mohr theory, 249
 - graphical representation, 249
- Modified Goodman theory, 288–289
- Modulus of elasticity:
 - axial, 6, 15
 - shear, 14, 15
- Moment of inertia:
 - circular beam, 31
 - flywheel, 389
 - rectangular beam, 25
- Mohr's Circle, 205
 - graphical process, 208
 - triaxial stress, 231
- Neutral axis, 24
- Notch sensitivity, 260, 283
- Number of active coils in a helical spring, 372
- Parabolic formula, 263
- Parallel arrangement of springs, 377–378
- Permanent joint bolt preload, 332
- Pin supports, 34
- Pitch of a helical spring, 380
- Plane stress element, 153–154, 189
- Planetary gears, 428–431
- Poisson's ratio, 7, 15
- Polar moment of inertia:
 - hollow shaft, 17
 - solid shaft, 17
 - thin-walled rectangular tube, 22
 - welded connection, 354
- Potential energy of a spring, 376
- Preload, bolt, 331–332
 - techniques to verify, 332
- Press fits, 134, 175
- Pressure:
 - contact:
 - between cylinders, 144
 - between spheres, 140
 - interface, 135
 - internal, 128

- Pressure loadings, 127, 172, 175, 184
summary table of formulas, 154
- Pressure vessels:
thin-walled:
cylindrical, 129, 191
spherical, 128
- Pressurized tank, 184, 190
- Principal stresses, 190, 195
- Prismatic bar, 4, 156, 258, 322
- Proof strength, 332
- Proportional limit, 6, 14
- Pulley systems, 435–437
- Punch press:
cycle, 396
flywheels, 395–398
- Punching time, 397
- Pure motions:
rotation, 412
translation, 412
- Pure shear element, 156
- Quick-return linkage, 411
- Radial interference, 135
- Radial stress, 131–132, 148
- Radius of gyration: 260
circular cross section, 265
rectangular cross section, 261
- Rated torque, 395
- Recovery time, punch presses, 397
- Relative motion, 412–415, 416–419
- Riveted joint, 11, 30
- Roller supports, 34
- Rolling wheels, 432–434
- Rotated plane stress element, 190, 205
- Rotating disk, 148
- R. R. Moore rotating-beam machine, 275
- Secant formula, 266
- Section modulus, 26
- Series arrangement of springs, 377–378
- Shear:
direct, 11
strain, 13, 19
stress, 12, 16, 22, 27
maximum, 196
minimum, 196
- Shear-stress correction factor, 370
- Shrink fits, 134, 175
- Simply-supported beams, 33, 35, 36, 41, 48, 55,
60, 67, 73, 79, 86, 92
- Single overhanging beams, 35, 73, 79
- Size factor for Marin equation, 280–281
- Slenderness ratio, 260, 261, 263, 266, 271
- Slider-crank linkage, 411
- S-N Diagram, 275–276
- Solid disk flywheel, 388–389
- Spheres:
thin-walled, 128
- Spring deflection, 371
- Spring index, 369
- Spring rate:
bolt, 322–323
capscrew, 322–323
frustum of a cone, 327
helical springs, 371–372
members in a bolted connection, 326–327
- Spur gears, 425–427
- Static design:
coordinate system, 234
brittle materials, 246
comparison with experimental data, 250
recommendations, 251–252
ductile materials, 234
comparison with experimental data, 238
recommendations, 238–239
theories:
Coulomb-Mohr, 248
Distortion-energy, 237
Maximum-normal-stress, 234, 247
Maximum-shear-stress, 235
Modified Coulomb-Mohr, 249
- Stability of helical springs, 381–382
- Static loading of bolted connections, 335–336
- Stiffness:
bolt, 322–323
capscrew, 322–323
frustum of a cone, 327
members in a bolted connection, 326–327
- Strain:
axial, 5
lateral, 7
shear, 13, 19
thermal, 10
- Strength, proof, 332
- Stress:
alternating, 285
average, 196
axial, 4, 129, 133–134
bending, 24
contact, 140, 144
critical, 261, 264, 266, 271

- direct shear, 12
- hoop, 129, 191
- mean, 285
- normal, in spheres, 128
- principal, 190
- radial, 131–132, 148
- shear, 16, 22, 27
- tangential, 131, 148
- thermal, 10
- triaxial, 230
- Stress-concentration factors, 258, 283, 304
- Stress elements:
 - biaxial, 148, 219, 223
 - maximum, 195
 - plane, 153, 205
 - pure shear, 156, 157, 219, 227
 - uniaxial, 155, 219
- Stress-strain diagrams:
 - axial loading:
 - brittle materials, 7
 - ductile materials, 6
 - high-strength bolt or capscrew, 332
 - shear loading:
 - brittle materials, 14
 - ductile materials, 14
- Supports:
 - cantilever, 33–34
 - pin, 34
 - roller, 34
- Surface finish factor for Marin equation, 280
- Synchronous angular velocity, 395
- Tangential stress, 130, 148
- Tee joint, 351
- Temperature factor in Marin equation, 282
- Tensile-stress area, 324, 331
- Thermal:
 - loading, 164
 - strain, 10
 - stress, 10
- Thick-walled cylinders, 130
- Thin rotating disks, 148
- Thin-walled:
 - tubes, 22
 - vessels, 128
 - cylindrical, 129
 - spherical, 128
- Thread length, 323–324
- Torque as a function of:
 - angular velocity, 395
 - rotation angle, 392
- Torque wrench method for bolt preload, 332
- Torsion, 16, 156, 167, 175
- Torsional loading:
 - fluctuating, 304–305
 - welded connections, 352–354
- Transformation equations, 190
- Transverse joint, 351, 352
- Triangular loading, 60, 120
- Triaxial stress, 230
- Turn-of-the-nut method for bolt preload, 332
- Two-stroke engine, 392
- Ultimate strength, 6, 14
- Uniaxial stress element, 155
- Uniform loading, 55, 79, 92, 115
- Velocity analysis, 412–415
- Vessels:
 - thin-walled:
 - cylinders, 129
 - spheres, 128
- Wahl factor, 370
- Welded connections, 348
- Wheels and pulleys, 431
- Work and energy, 375–376
- Yield point, 6, 14



This page intentionally left blank.

ABOUT THE AUTHOR

Thomas H. Brown, Jr., Ph.D., P.E., manages the Fundamentals of Engineering Review Program and the Civil Engineering Professional Engineering Review Program at the Institute for Transportation Research and Education at North Carolina State University. Dr. Brown has taught review courses for the Mechanical Engineering Professional Engineering Review Program offered by the Industrial Extension Service and taught undergraduate machine design courses for almost a dozen years in the Mechanical and Aerospace Engineering Department, both in the College of Engineering at North Carolina State University.