

Tolerancing Optimization Strategies

Gregory A. Hetland, Ph.D.
Hutchinson Technology Inc.
Hutchinson, Minnesota

Dr. Hetland is the manager of corporate standards and measurement sciences at Hutchinson Technology Inc. With more than 25 years of industrial experience, he is actively involved with national, international, and industrial standards research and development efforts in the areas of global tolerancing of mechanical parts and supporting metrology. Dr. Hetland's research has focused on "tolerancing optimization strategies and methods analysis in a sub-micrometer regime."

3.1 Tolerancing Methodologies

This chapter will give a few examples to show the technical advantages of transitioning from linear dimensioning and tolerancing methodologies to geometric dimensioning and tolerancing methodologies. The key hypothesis is that geometric dimensioning and tolerancing strategies are far superior for clearly and unambiguously representing design intent, as well as allow the greatest amount of tolerance.

Geometric definitions can have only one clear technical interpretation. If there is more than one interpretation of a technical requirement, it causes problems not only at the design level, but also through manufacturing and quality. This problem not only adds confusion within an organization, but also adversely affects the supplier and customer base. This is not to say that utilization of geometric dimensioning and tolerancing will always make the drawing clear, because any language not used correctly can be misunderstood and can reflect design intent poorly.

3.2 Tolerancing Progression (Example #1)

Figs. 3-1 to 3-3 show three different dimensioning and tolerancing strategies that are "intended" to reflect designer's intent, and the supporting figures are intended to show the degree of variation allowed by the defined strategy. These three strategies reflect a progression of attempts to accomplish this goal.

3-2 Chapter Three

Fig. 3-3 depicts the optimum dimensioning and tolerancing strategy reflecting the greatest allowable flexibility for the designer and manufacturer. Note: Each of the drawings/figures is complete only to the degree necessary to discuss the features in question.

Prior to elaborating on each of the strategies, it is critical to understand what the designer was attempting to allow on the initial design. In this case, the designer intends to have the external boundary utilize a space of $6.35 \text{ mm} \pm 0.025 \text{ mm}$ “square,” and to have the hub (inside diameter) on “center” of the square within $\pm 0.025 \text{ mm}$. With this being the designer’s goal, consider the following three strategies of dimensioning and tolerancing.

3.2.1 Strategy #1 (Linear)

Fig. 3-1a represents the original dimensioning and tolerancing strategy that is strictly linear. In this figure, the outside shape in the vertical and horizontal directions is $6.35 \text{ mm} \pm 0.025 \text{ mm}$, while the hub is located at half the distance of the nominal width from the center of the part. Section A-A shows the allowable variation for the inside diameter.

Based on the defined goal of the designer, there are a number of problems that arise based on interpretation of any given national or international standard that exists today or in the past. All comments in this section will be limited to interpretation of the ASME Y14.5M-1994 (Y14.5) standard. It is critical to note that no industrial or company specification existed that would state anything different (related to reducing the ambiguities based on utilizing linear tolerancing methodologies) from the Y14.5 standard.

Paragraph 2.7.3 of Y14.5 addresses the “relationship between individual features,” and states:

The limits of size do not control the orientation or location relationship between individual features. Features shown perpendicular, coaxial, or symmetrical to each other must be controlled for location or orientation to avoid incomplete drawing requirements.

Based on the above-noted paragraph, it clearly indicates Fig. 3-1a to be lacking at least some geometric controls or at a minimum some notes to identify the degree of orientation and locational control. Figs. 3-1b to 3-1g show a few of the possible combinations of part variability (represented by dashed lines) that are allowed by the current “linear” callouts.

Fig. 3-1b shows a part perfectly square and made to its maximum size based on the tolerance specification (6.375 mm), which would be an acceptable part for size. Assuming the hub was exactly in the center where the designer would like it to be, this feature would measure 0.0125 mm off its ideal location based on this part’s large size. Ideal nominal was 3.175 mm , and the actual value measured was 3.1875 mm , which would be a displacement of 0.0125 mm . It meets intended ideal, but fails specified ideal.

Like Fig. 3-1b, Fig. 3-1c shows a part that is perfectly square but is now made to its minimum allowable size based on specification (6.325 mm), which is again acceptable for size. Assuming the hub was exactly in the center where the designer would like it to be, this part also would measure 0.0125 mm off its ideal location based now on the part’s small size. The ideal nominal was 3.175 mm , and the actual value measured was 3.1625 mm , which also shows a displacement of 0.0125 mm . Again, it meets intended ideal, but fails specified ideal.

Paragraph 2.7.3 of Y14.5 stated that “the limits of size do not control the orientation.” Fig. 3-1d describes the condition that can occur based on the lack of geometric control for orientation. In this example, the part is restricted to the shape of a parallelogram, and the degree allowed is questionable. This particular example clearly shows the designer’s intent would not be met if this condition was accepted. Based on the drawing callouts currently defined, it could not be rejected.

Fig. 3-1e shows a combination of Figs. 3-1b and 3-1c where it allows the shape to be small at one end and large at the other. Fig. 3-1f takes this one step further and shows a part that is, for the most part, large, except all the variability (0.05 mm) shows up on one edge.

Fig. 3-1g is showing a part made to its large size (like Fig. 3-1b), and the hub shifted off the “designer’s ideal” center, so it is centered on its nominal dimension. This figure also shows the effect this would have on its opposing corner which would be a displacement out to its worst-case tolerance of +0.025 mm (3.2 mm). The more challenging part would be to determine which edge is being measured, from one part to the next. This is somewhat difficult to do on a part that is designed perfectly symmetrical.

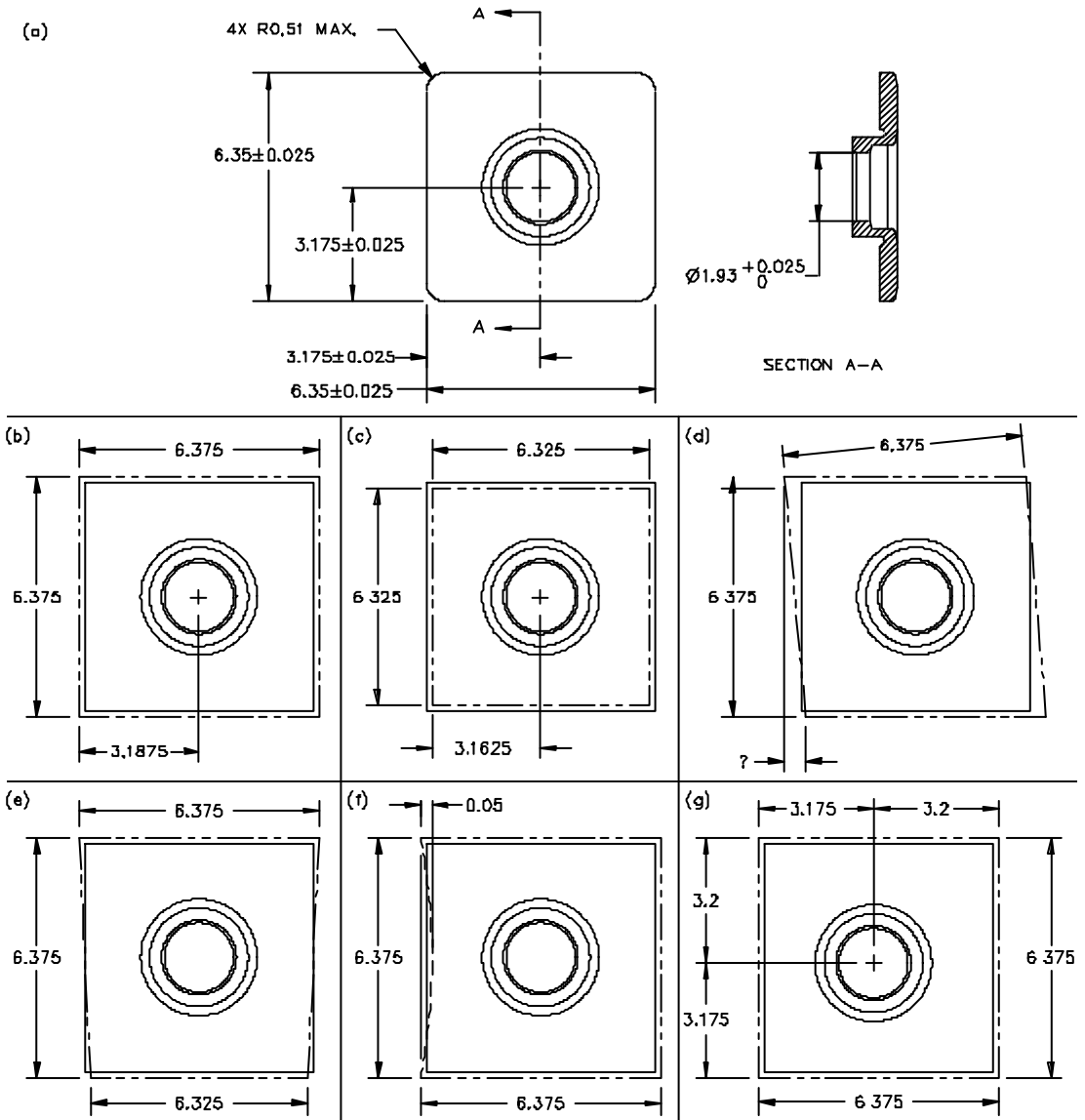

Figure 3-1 Linear dimensioning and tolerancing boundary example

The above comments are not intended to identify all the potential problems, or even to touch on the probability of occurrence. These comments should identify a few obvious problems with this particular dimensioning and tolerancing strategy. It did not take long for the designer to realize this particular drawing was missing requirements to state what was intended to be allowed. Based on some initial training in geometric dimensioning and tolerancing, the designer modified the drawing as shown in Fig. 3-2a. This leads into strategy #2 which is a combination of linear and geometric tolerancing.

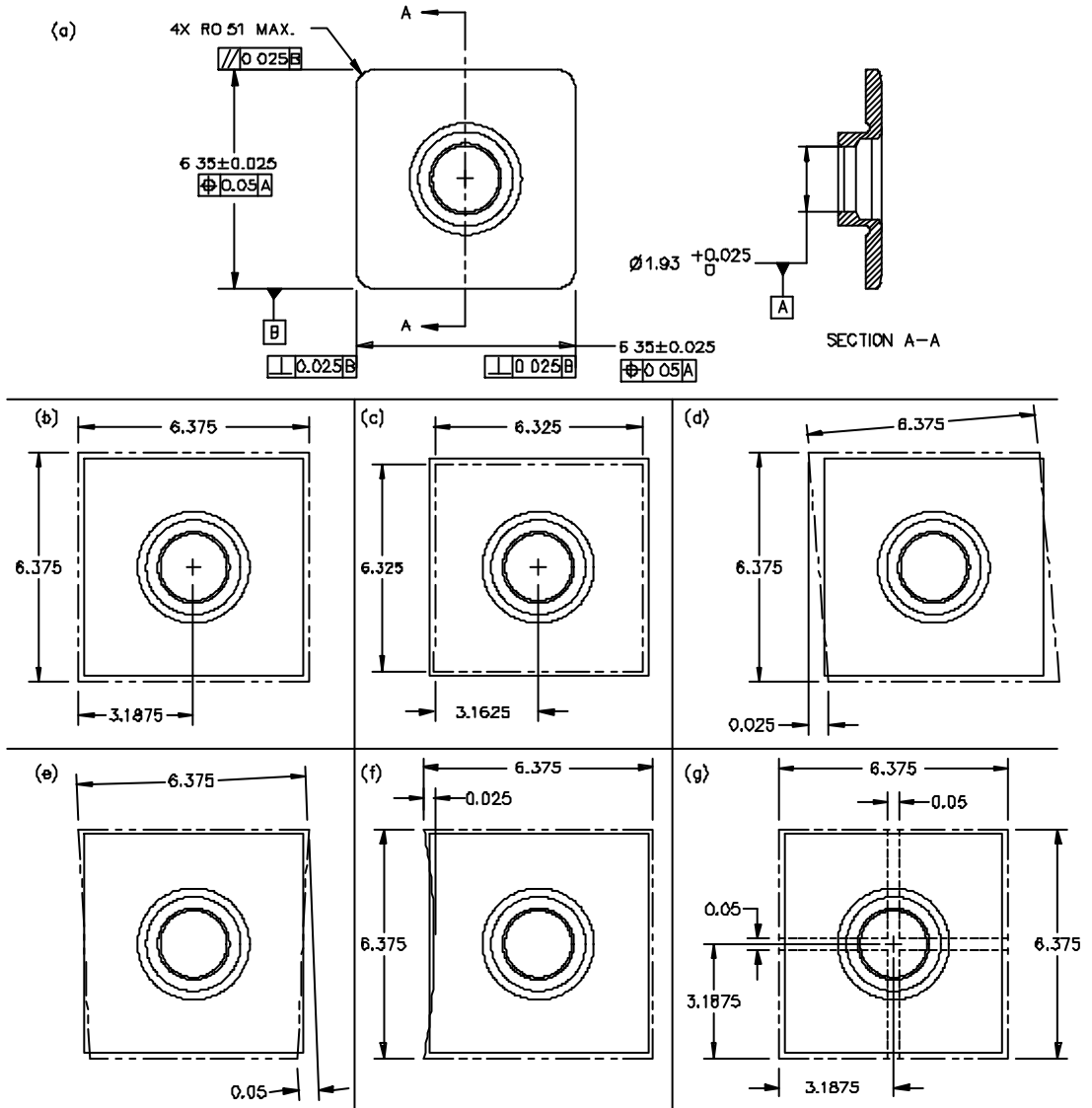

Figure 3-2 Linear and geometric dimensioning and tolerancing boundary example

3.2.2 Strategy #2 (Combination of Linear and Geometric)

Fig. 3-2a is a combination of linear and geometric callouts, and clearly adds controls for orientation of one surface to another. This is achieved with perpendicularity callouts on the left and right sides of the part in relationship to datum -B-, along with a parallelism callout on the top of the part, also to datum -B-. In addition, position callouts were added to each of the size dimensions ($6.35 \text{ mm} \pm 0.025 \text{ mm}$) and were controlled in relationship to datum -A-, which is the “axis” of the inside diameter ($1.93 \text{ mm} +0.025 \text{ mm} / -0 \text{ mm}$). Figs. 3-2b to 3-2g define some of the conditions allowed by these drawing callouts.

Fig. 3-2b shows a part perfectly square and made to its maximum size based on the specification (6.375 mm), which would be an acceptable part for size. Assuming the hub was exactly in the center where the designer would like it to be, this part would measure 3.1875 mm . Unlike the negative impact mentioned in regards to Fig. 3-1b, this measurement adds no negative impact to specifications because the “center plane” is now being located from the “center” of the inside diameter.

Like Fig. 3-2b, Fig. 3-2c shows a part that is perfectly square and made to its minimum allowable size based on the specifications (6.325 mm), which is again acceptable for size. Again, assuming the hub was exactly in the center where the designer would like it to be, the 3.1625 mm measurement has no negative impact on specifications.

Fig. 3-2d (like Fig. 3-1d) shows a part on the large side of the tolerance allowed, with its orientation skewed to the shape of a parallelogram. In this example, however, the perpendicularity callouts added in Fig. 3-2a control the amount this condition can vary. In this case it is 0.025 mm . The problem that stands out here is that the designer’s original intent stated: to have the external boundary utilize a space of $6.35 \text{ mm} \pm 0.025 \text{ mm}$ “square.” Based on this requirement, it’s clear this objective was not met. Granted, it is controlled tighter than the requirements defined in Fig. 3-1a, but it still does not meet the designer’s expectations.

Fig. 3-2e shows a combination of Figs. 3-2b and 3-2c (like Figs. 3-1b and 3-1c), in that it allows the shape to be small at one end and large at the other. Unlike Figs. 3-1b and 3-1c, Fig. 3-2e restricts the magnitude of change from one end to the other by the parallelism and perpendicularity callouts shown in Fig. 3-2a.

Because this part is symmetrical, a unique problem surfaces in this example. Using Fig. 3-2e, assuming the bottom surface is datum -B-, the top surface is shown to be perfectly parallel. Due to the part being symmetrical, it is impossible to determine which surface is truly datum -B-. So, if we assume the left-hand edge of the part as shown in Fig. 3-2e was the datum, the opposite surface (based on the shape shown) would show to be out of parallel by 0.05 mm . This clearly shows that problems in the geometric callouts are not only in the design area, but also in the ability to measure consistently. Like-type parts could measure good or bad, depending on the surface identified as datum -B-.

Fig. 3-2f again shows displacement in shape allowed. In this case it shows a part that is for the most part large, except all the variability (0.025 mm) shows up on one edge. The limiting factor (depending on which surface is “chosen” as datum -B-) is the perpendicularity or parallelism callouts.

Fig. 3-2g is showing a part made to its large size (like Fig. 3-1b), and the 0.05 mm zone allowed by the position callout. Unlike Fig. 3-1g, the larger or smaller size of the square shape has no impact on the position. Based on the callout in Fig. 3-2a, the center planes (mid-planes) in both directions must fall inside the dashed boundaries.

The above comments concerning Fig. 3-2a are intended to show a tolerancing strategy that encompasses both linear and geometric callouts but still does not meet the designer’s intended expectations. Based on this, the designer modified the drawing again, as shown by Fig. 3-3a, which led to strategy #3.

3.2.3 Strategy #3 (Fully Geometric)

Fig. 3-3a is the optimum dimensioning and tolerancing strategy for this design example. In this case, the outside shape is defined clearly as a square shape that is 6.35 mm “basic,” and is controlled with two profile callouts. The 0.05 mm tolerance is shown in relationship to datums -B- and -A-, controlling primarily the “location” of the hub in relation to the outside shape (depicted by Fig. 3-3b). The 0.025 mm tolerance is shown in relationship to datum -B- and controls the total variation of “shape” (depicted by Fig. 3-3c). This tolerancing strategy clearly defines the designer’s intent.

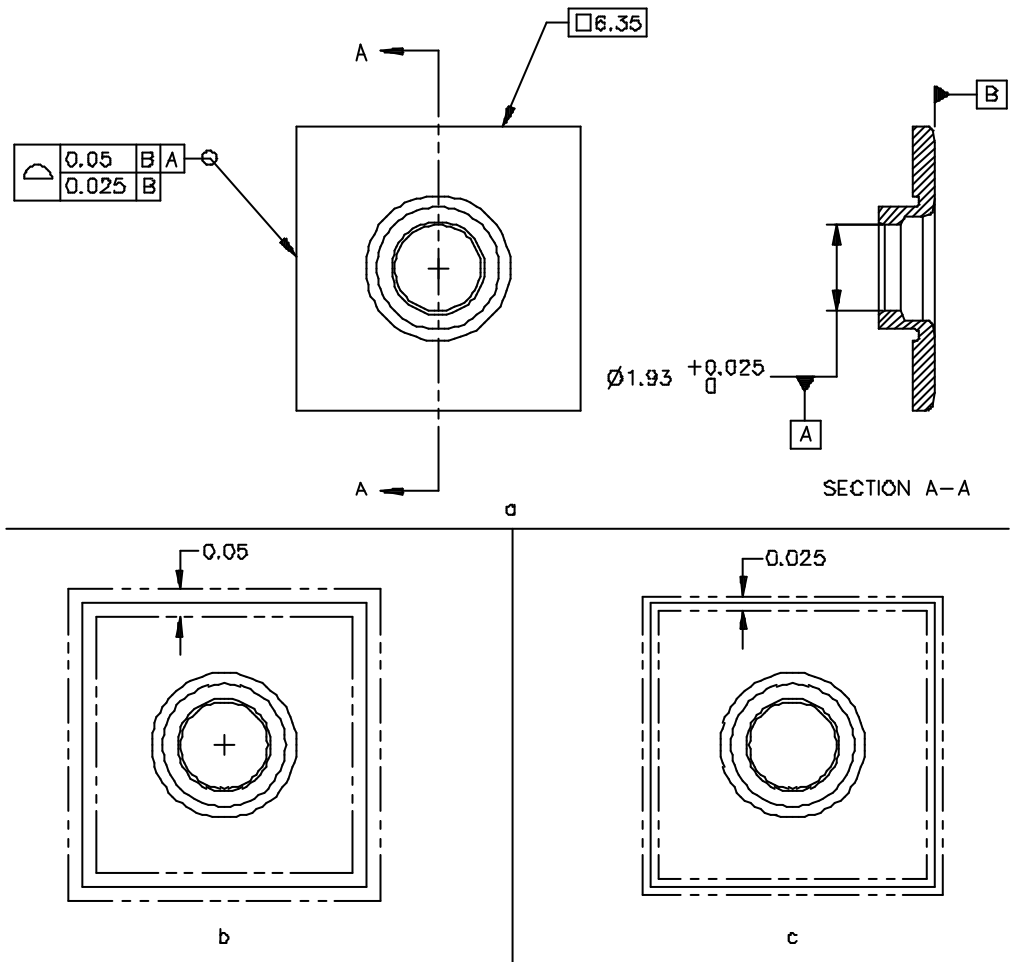

Figure 3-3 Fully geometric dimensioned and toleranced boundary example

3.3 Tolerancing Progression (Example #2)

This second example is intended to show the tolerancing progression for locating two mating plates (one plate with four holes and the other with four pins). Design intent requires both plates to be located within a size and location tolerance that will allow them to fit together, with a worst-case fit to be no tighter than a “line-to-line” fit. In addition, the relationship of the holes to the outside edges of the part is critical.

The tolerance progression will start with linear dimensioning methodologies and will progress to using geometric symbology, which in this case will be position. This progression will conclude with the optimum tolerancing method for this design application, which will be a positional tolerance using zero tolerance at maximum material condition (MMC). All examples will follow the same “design intent” and use the same two plate configurations.

Initially, each figure showing a tolerancing progression will be displayed showing a “front and main view” for each part, along with a “tolerance stack-up graph” at the bottom of the figure (see Fig. 3-4 as an example). The component on the left will always show the part with four inside diameter holes, while the component on the right will always show the part with four pins. The tolerance stack-up graph will show the allowable location versus allowable size as they relate to the applicable component on their respective sides.

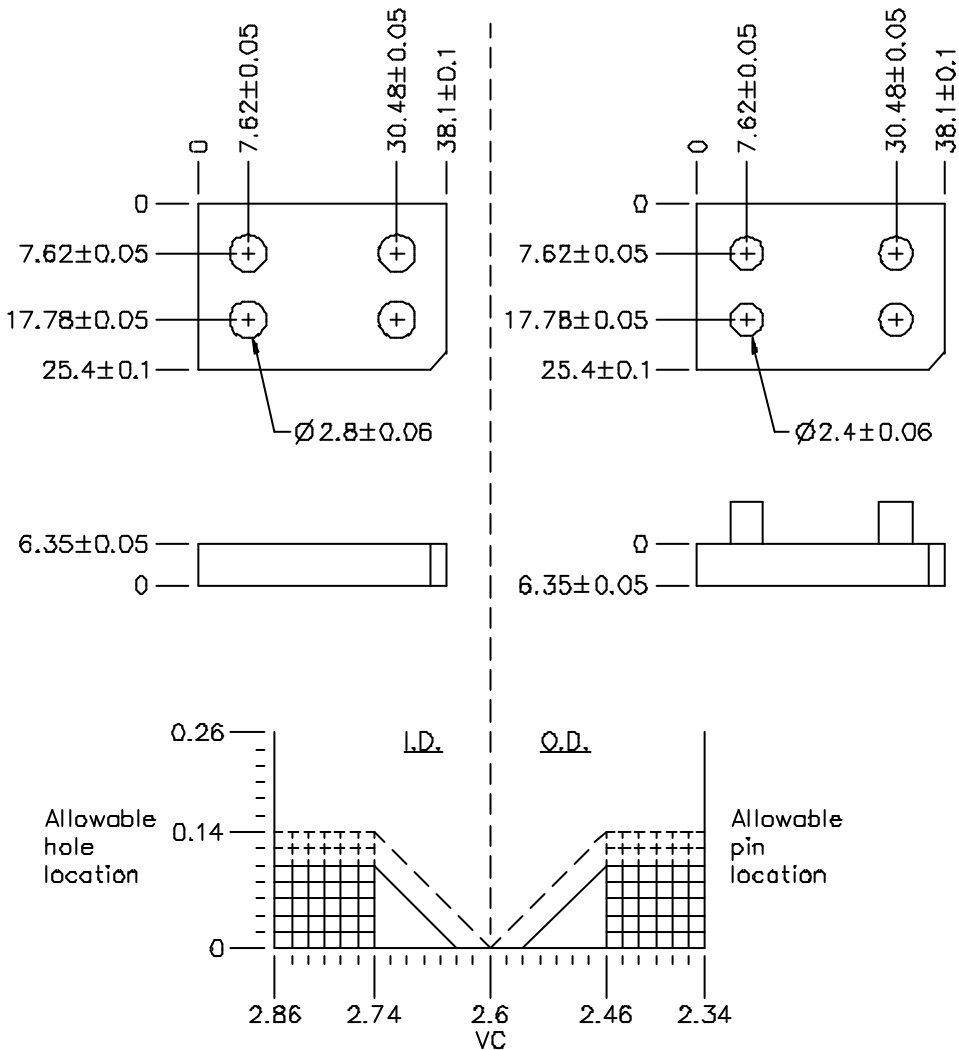

Figure 3-4 Tolerance stack-up graph (linear tolerancing)

The critical items to follow in this example (as well as subsequent examples) are the dimensioning and tolerancing controls and the associative “tolerance stack-up” that occurs. Common practice for designers is to identify the worst-case condition that each component will allow, to ensure the components will assemble. This tolerance stack-up will be displayed graphically within each of the figures, such as the one shown at the bottom of Fig. 3-4.

Each component will be specified showing nominal size and tolerance for the inside diameter (2.8 mm \pm ?? mm) and outside diameter (2.4 mm \pm ?? mm “pins”). The size tolerance will change in some of the progressions, and the positional requirements will change in “each” of the progressions, both of which will be variables to monitor in the tolerance stack-up graph. The tolerance stack-up graph is the primary visual tool that monitors primary differences in the callouts. More filled-in graph area indicates that more tolerance is allowed by the dimensioning and tolerancing strategy.

To clarify the components of the graph so they are interpreted correctly, continue to follow along in Fig. 3-4. The horizontal scale of the graph shows size variation allowed by the size tolerance, while the vertical scale shows locational variation allowed by the feature’s locational tolerance. Each square in the grid equals 0.02 mm for convenience. The center of the horizontal scale represents (in these examples) the “virtual condition” (VC), which is the worst case stack-up allowed by both components as the size and locational tolerances are combined. This condition tests for the line-to-line fit required by the designer.

Based on the above classifications, the reader should be able to follow along more easily with the differences in the following figures.

3.3.1 Strategy #1 (Linear)

Fig. 3-4 represents the original dimensioning and tolerancing strategy that is strictly “linear.” The left side of the graph shows the allowable tolerance for the “inside diameter” to range from 2.74 mm to 2.86 mm, reflected by the numbers on the horizontal scale. The positional tolerance allowed in this example is 0.05 mm from its targeted (defined) nominal, or a total tolerance of 0.1 mm, reflected by the numbers on the vertical scale. The grid (solid line portion) indicates the combined size and locational variation “initially perceived” to be allowed as the drawing is currently defined.

The solid line that extends from the upper right corner of the “solid grid” pattern (intersection of 0.1 on the vertical scale and 2.74 on the horizontal scale) down to the 2.64 mark on the horizontal scale, represents the perceived virtual condition based on the noted tolerances. This area does not show up as a grid pattern (in this figure), because the actual space is not being used by either the size or positional tolerance.

The normal calculation for determining the virtual condition boundary is to take the MMC of the feature and subtract or add the allowable positional tolerance. This depends on whether it is an inside or outside diameter feature (subtract if it’s an inside diameter, and add if it’s an outside diameter). In this case, the MMC of the inside diameter is 2.74 mm and subtracting the allowable positional tolerance of 0.1 mm would derive a virtual condition of 2.64 mm.

This is where the first concern arises, which is depicted by the dashed grid area on the graph. Prior to detailed discussion on this dashed grid area, an explanation of the problem is necessary.

Fig. 3-5 reflects a tolerance zone comparison between a square tolerance zone and a diametral tolerance zone shown to be centered on the noted cross-hair. At the center of the figure is a cross-hair intended to depict the center axis of any one of the holes or pins, defined by the nominal location. In this example, use the upper-left hole shown in Fig. 3-4, which is equally located from the noted (zero) surfaces by 7.62 mm “nominal” in the x and y axes. In the center of this hole (as well as all others) there is a small cross-hair depicting the theoretically exact nominal. Based on the nominals noted, there is an allowable tolerance of 0.05 mm in the x and y axes.

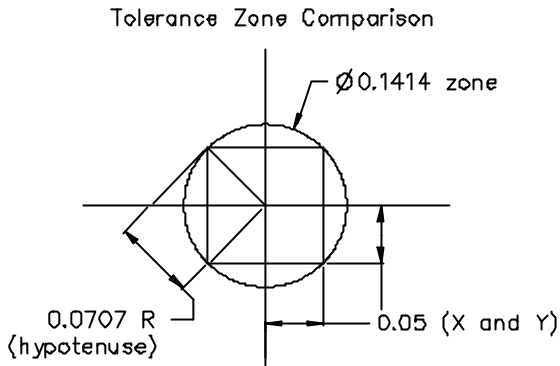

$$2 \sqrt{\Delta X^2 + \Delta Y^2} = \varnothing \text{ tolerance zone}$$

$$2 \sqrt{0.05^2 + 0.05^2} = 2(0.0707) = 0.1414 \varnothing \text{ tolerance zone}$$

Note: ± 0.05 square zone = \varnothing zone of 0.1414

Note: Benefit of changing square zone to diameter tolerance zone is

- *Increases position tolerance zone by 57 %
- *Allows use of MMC principle

Figure 3-5 Plus/minus versus diametral tolerance zone comparison

The square shape shown in Fig. 3-5 represents the ± 0.05 mm location tolerance. In evaluating the square tolerance zone, it becomes evident that from the center of the cross-hair, the axis of the hole can be further off (radially) in the corner than it can in the x and y axes. Calculating the magnitude of radial change shows a significant difference (0.05 mm to 0.0707 mm). The calculations at the bottom of Fig. 3-5 show a total conversion from a square to a diametral tolerance zone, which in this case yields a diametral tolerance boundary of 0.1414 mm (rounded to 0.14 mm for convenience of discussion).

Now, looking back at the graph in Fig. 3-4, the dashed grid area should now start to make some sense. The square (0.05 mm) tolerance boundary actually creates an awkward shaped boundary that under certain conditions can utilize a positional boundary of 0.14 mm. Based on this, the following is a recalculation of the virtual condition boundary. In this case, the MMC of the inside diameter is still 2.74 mm, and now subtracting the “potentially” allowable positional tolerance of 0.14 mm derives a virtual condition of 2.6 mm, which is what the second line (dashed) is intended to represent.

It should become very obvious that it makes little sense to tolerance the location of a round hole or pin with a square tolerance zone. Going on this premise, the two parts would, in fact, assemble if the location of a given hole (or pin) was produced at its maximum x and y tolerance. It would make sense to identify the tolerance boundary as diametral (cylindrical). The parts in fact will assemble based on this condition, which is why geometric tolerancing in Y14.5 progressed in this fashion. It needed some methodology to represent the tolerance boundary for the axes of the holes. A diametral boundary is one reason for the position symbol.

Up to this point, in referring to Fig. 3-4, comments have been limited to the part on the left side with the through holes. All comments apply in the same fashion to the part on the right side, except for the minor change in calculating the virtual condition. In this case, the maximum material condition of the pin is a diameter of 2.46 mm, so “adding” the allowable positional tolerance of 0.14 mm would result in a virtual condition boundary of 2.6 mm.

3-10 Chapter Three

Additional problems surface when utilizing linear tolerancing methodologies to locate individual holes or hole patterns, such as the ability to determine which surfaces should be considered as primary, secondary, and tertiary datums or if there is a need to distinguish a difference at all.

This ambiguity has the potential of resulting in a pattern of holes shaped like a parallelogram and/or being out of perpendicular to the primary datum or to the wrong primary datum. At a minimum, inconsistent inspection methodologies are natural by-products of drawings that are prone to multiple interpretations.

The above comments and the progression of Y14.5 leads to the utilization of geometric tolerancing using a feature control frame, and in this case specifically, the utilization of the position symbol, as shown in Fig. 3-6.

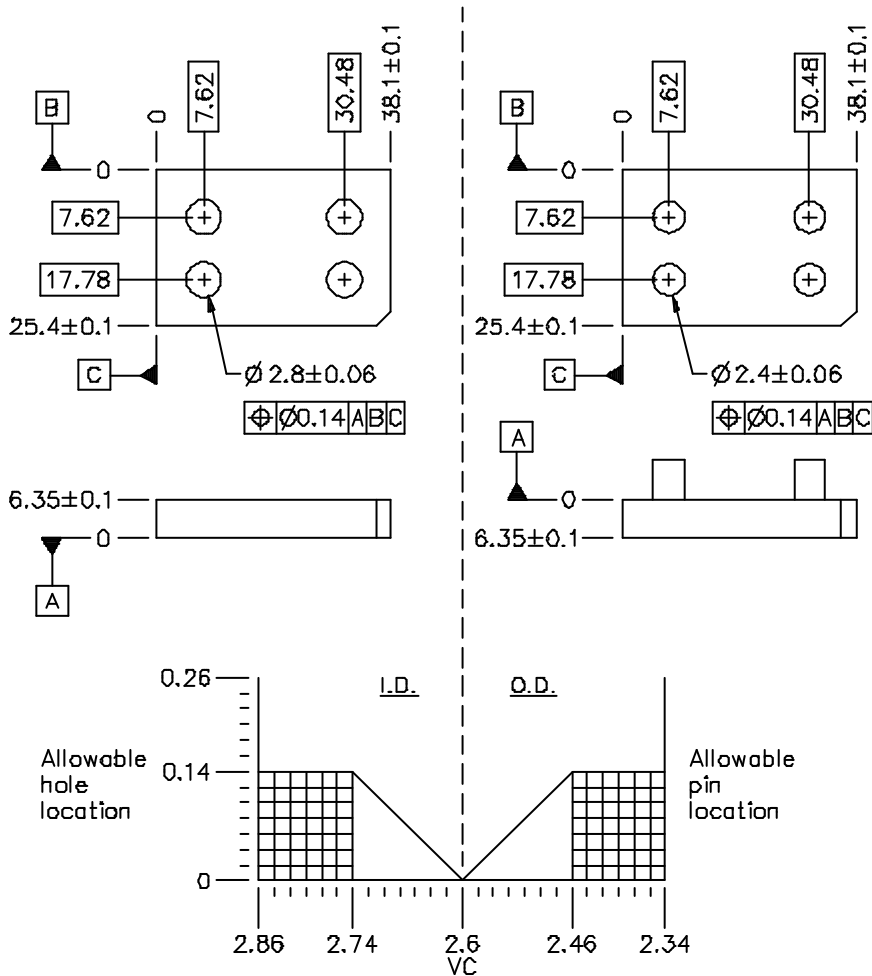

Figure 3-6 Tolerance stack-up graph (position at RFS)

3.3.2 Strategy #2 Geometric Tolerancing (\oplus) Regardless of Feature Size

Fig. 3-6 shows the next progression using geometric tolerancing strategies. Tolerances for size are identical to Fig. 3-4. The only change is limited to the locational tolerances. In this example, the tolerance has been removed from the nominal locations and a box around the nominal location depicts it as being a “basic” (theoretically exact) dimension. The locational tolerance that relates to these basic dimensions is now located in the feature control frames, shown under the related features of size.

The diametral/cylindrical tolerance of 0.14 mm should look familiar at this point, as it was discussed earlier in relation to Figs. 3-4 and 3-5. This is a geometrically correct callout that is clear in its interpretation. The datums are clearly defined along with their order of precedence, and the tolerance zone is descriptive for the type of features being controlled.

The feature control frame would read as follows: The 2.8 mm holes (or 2.4 mm pins) are to be positioned within a cylindrical tolerance of 0.14 mm, regardless of their feature sizes, in relationship to primary datum -A-, secondary datum -B-, and tertiary datum -C-.

The graph at the bottom of Fig. 3-6 clearly describes the size and positional boundaries, along with associative lines depicting the virtual condition boundary, as noted in Fig. 3-4. Based on all the issues discussed in relation to Fig. 3-4, this would seem to be a very good example for positive utilization of geometric tolerances. There is, however, an opportunity that was missed by the designer in this example. It restricted flexibility in manufacturing as well as inspection and possibly added cost to each of the components.

Now a re-evaluation of the initial design criteria: Design intent required both plates to be dimensioned and located within a size and location tolerance that is adequate to allow them to fit together, with a worst-case fit to be no tighter than a “line-to-line” fit. In addition, the relationship of the holes to the outside edges of the part is critical.

Based on this, re-evaluate the feature control frame and the graph. It states the axis of the holes or pins are allowed to move around anywhere within the noted cylindrical tolerance of 0.14 mm, “regardless of the features size.” This means that it does not matter whether the size is at its low or high limit of its noted tolerance and that the positional tolerance of 0.14 mm does not change.

It would make sense that if the hole on a given part was made to its smallest size (2.74 mm) and the pin on a given mating part was made to its largest size (2.46 mm), that the worst case allowable variation that could be allowed for position would each be 0.14 mm (2.74 mm - (minus) 2.46 mm = 0.28 mm total variation allowed between the two parts). The graph clearly shows this condition to reflect the worst case line-to-line fit.

If, however, the size of the hole on a given part was made to its largest size (2.86 mm) and the pin on a given mating part was made to its smallest size (2.34 mm), it would make sense that the worst case allowable positional variation could be larger than 0.14. Evaluating this further as was done above to determine a line-to-line fit would be as follows: 2.86 mm - 2.34 mm = 0.52 mm total variation allowed between the two parts.

The graph clearly indicates this condition. It would seem natural, due to the combined efforts of size and positional tolerance being used to determine the worst-case virtual condition boundary, that there should be some means of taking advantage of the two conditions. Fig. 3-7 depicts the flexibility to allow for this condition, which is the next step in this tolerance progression.

3.3.3 Strategy #3 (Geometric Tolerancing Progression at Maximum Material Condition)

Fig. 3-7 shows the next progression of enhancing the geometric strategy shown in Fig. 3-6. All tolerances are identical to Fig. 3-6. The only difference is the regardless of feature size condition noted in the feature control frame is changed to maximum material condition. Again, this would be considered a clean callout.

The feature control frame would now read as follows: The 2.8 mm holes (or 2.4 mm pins) are to be positioned within a cylindrical tolerance of 0.14 mm, at its maximum material condition, in relationship to primary datum -A-, secondary datum -B-, and tertiary datum -C-.

The graph at the bottom of Fig. 3-7 clearly describes the size and positional boundaries along with associative lines depicting the virtual condition boundary. Unlike Figs. 3-4 and 3-6, the grid area is no

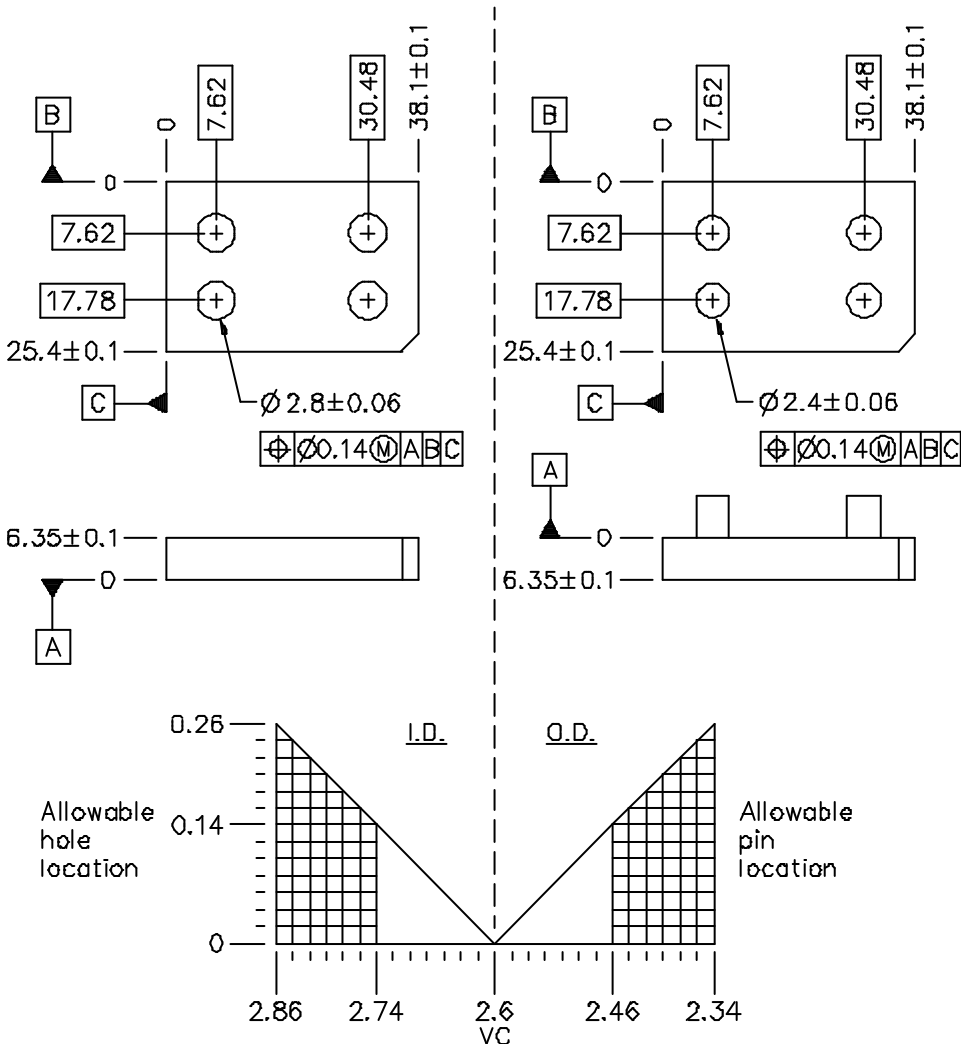

Figure 3-7 Tolerance stack-up graph (position at MMC)

longer rectangular. The range of the size boundary has not changed, but the range of the allowable positional boundary has changed significantly, due solely to the additional area above 0.14 mm being a function of size.

Evaluation of the feature control frame and graph depict the axis of the holes or pins, allowed to move around anywhere within the noted cylindrical tolerance of 0.14 mm when the feature is produced at its maximum material condition. The twist here is that as the feature departs from its maximum material condition, the displacement is additive one-for-one to the already defined positional tolerance. This supports the previous comments very well. Table 3-1 identifies the bonus tolerance gained to position as the feature's size is displaced from its maximum material condition and can be visually followed on the graph in Fig. 3-7.

Table 3-1 Bonus tolerance gained as the feature's size is displaced from its MMC

Feature Size	Displacement from MMC	Allowable Position Tolerance
2.74	0.00	0.14
2.76	0.02	0.16
2.78	0.04	0.18
2.80	0.06	0.20
2.82	0.08	0.22
2.84	0.10	0.24
2.86	0.12	0.26

The combined efforts of size and positional tolerance utilized in this fashion is a clean way of taking advantage of the two conditions. Individuals involved with the Y14.5 committee recognize this. There is, however, an opportunity here that still restricts "optimum" flexibility in many aspects. Fig. 3-8 depicts the flexibility to allow for this condition, which is the final step in this tolerance progression.

3.3.4 Strategy #4 (Tolerancing Progression "Optimized")

Fig. 3-8 shows the final/optimum strategy of this tolerancing progression. Both size and positional tolerances have been changed to reflect the spectrum of design, manufacturing, and measurement flexibility. Nominals for size were kept the same only for consistency in the graphs.

This tolerancing strategy is an extension of the concept shown in Fig. 3-7 that allowed bonus tolerancing for the locational tolerance to be gained as the feature departed from its maximum material condition. In similar fashion, the function of this part allows the flexibility to also add tolerance in the direction of size. In this case, when less locational tolerance is used, more tolerance is available for size.

The feature control frame now reads as follows: The 2.8 mm holes (or 2.4 mm pins) are to be positioned within a cylindrical tolerance of "0" (zero) at its maximum material condition in relationship to primary datum -A-, secondary datum -B-, and tertiary datum -C-.

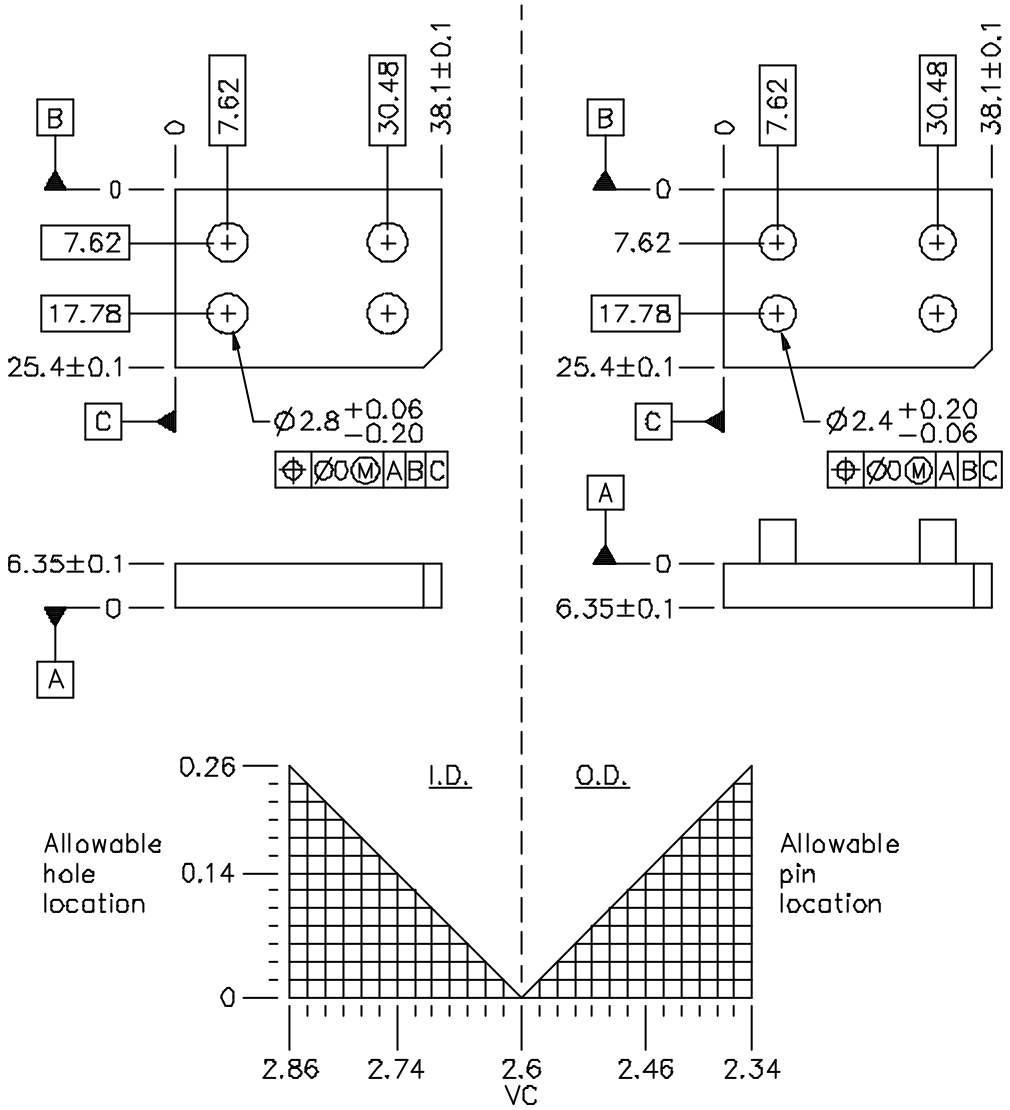

Figure 3-8 Tolerance stack-up graph (zero position at MMC)

According to the graph, when the feature is produced at its maximum material condition, there is no tolerance. But as the feature departs from its maximum material condition, its displacement is equal to the allowable tolerance for position. This supports the comments considered before very well. The same type of matrix as shown before could be developed to identify bonus tolerance gained to position as the feature's size is displaced from its maximum material condition. It can naturally be followed on the graph.

The virtual condition boundary still creates a worst case condition of 2.6 mm. The maximum material condition of both components now equals a cylindrical boundary of 2.6 mm, which means there is nothing left over for positional tolerance to be split between the two components.

3.4 Summary

Fig. 3-9 shows a summary of the boundaries each of the geometric progressions allowed. Each of these progressions is allowed by the current Y14.5 standard, but the flexibilities are not clearly understood. The intent of outlining these optimization strategies is to highlight the types of opportunities and strengths this engineering language makes available to industry in a sequential/graphical methodology.

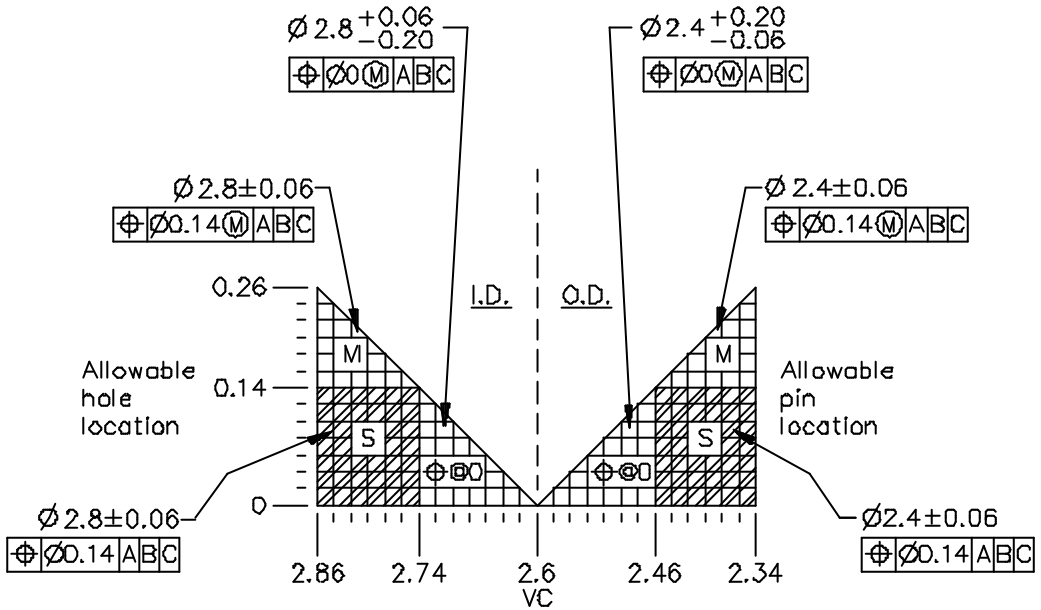

Figure 3-9 Summary graph

3.5 References

1. Hetland, Gregory A. 1995. Tolerancing Optimization Strategies and Methods Analysis in a Sub-Micrometer Regime. Ph.D. dissertation.
2. The American Society of Mechanical Engineers. 1995. ASME Y14.5M-1994, Engineering Drawings and Related Documentation Practices. New York, New York: The American Society of Mechanical Engineers.