

# Predicting Assembly Quality (Six Sigma Methodologies to Optimize Tolerances)

**Dale Van Wyk**  
**Raytheon Systems Company**  
**McKinney, Texas**

*Mr. Van Wyk has more than 14 years of experience with mechanical tolerance analysis and mechanical design at Texas Instruments' Defense Group, which became part of Raytheon Systems Company. In addition to direct design work, he has developed courses for mechanical tolerancing and application of statistical principles to systems design. He has also participated in development of a U.S. Air Force training class, teaching techniques to use statistics in creating affordable products. He has written several papers and delivered numerous presentations about the use of statistical techniques for mechanical tolerancing. Mr. Van Wyk has a BSME from Iowa State University and a MSME from Southern Methodist University.*

## 11.1 Introduction

We introduced the traditional approaches to tolerance analysis in Chapter 9. At that time, we noted several assumptions and limitations that (perhaps not obvious to you) are particularly important in the root sum of squares and modified root sum of squares techniques. These assumptions and limitations introduce some risk that defects will occur during the assembly process. The problem: There is no way to understand the magnitude of this risk or to estimate the number of defects that will occur. For example, if you change a tolerance from .010 to .005, the RSS Model would assume that a different process with a higher precision would be used to manufacture it. This is not necessarily true.

## 11.2 What Is Tolerance Allocation?

In this chapter, we will introduce and demonstrate methods of tolerance allocation. Fig. 11-1 shows how tolerance allocation differs from tolerance analysis. Tolerance analysis is a process where we assign

## 11-2 Chapter Eleven

tolerances to each component and determine how well we meet a goal or requirement. If we don't meet the goal, we reassign or resize the tolerances until the goal is met. It is by nature an iterative process.

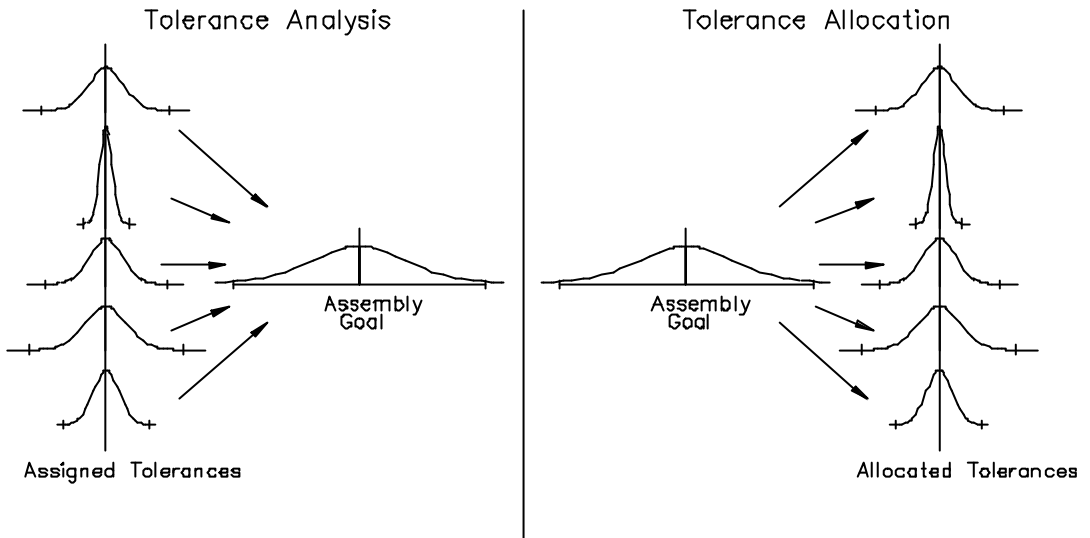

**Figure 11-1** Comparison of tolerance analysis and tolerance allocation

With tolerance allocation, we will present methods that will allow us to determine the tolerance to assign to each of the components with the minimum number of iterations. We will start with the defined goal for the assembly, decide how each component part will be manufactured, and allocate tolerances so that the components can be economically produced and the assembly will meet its requirements.

### 11.3 Process Standard Deviations

Prior to performing a tolerance allocation, we need to know how we're going to manufacture each component part. We'll use this information, along with historical knowledge about how the process has performed in the past, to select an expected value for the standard deviation of the process. We will use this in a similar manner to what was introduced in Chapter 10 and make estimates of both assembly and component defect rates. In addition we will use data such as this to assign tolerances to each of the components that contribute to satisfying an assembly requirement.

In recent years, many companies have introduced statistical process control as a means to minimize defects that occur during the manufacturing process. This not only works very well to detect processes that are in danger of producing defective parts prior to the time defects arise, but also provides data that can be used to predict how well parts can be manufactured even before the design is complete. Of interest to us is the data collected on individual features. For example, suppose a part is being designed and is expected to be produced using a milling operation. A review of data for similar parts manufactured using a milling process shows a typical standard deviation of .0003 inch. We can use this data as a basis for allocating tolerances to future designs that will use a similar process. It is extremely important to understand how the parts are going to be manufactured prior to assigning standard deviations. Failure to do so will yield unreliable results, and potentially unreliable designs. For example, if you conduct an analysis assuming a feature will be machined on a jig bore, and it is actually manufactured on a mill, the latter is less precise, and has a larger standard deviation. This will lead to a higher defect rate in production than predicted during design.

If data for your manufacturing operations is not available, you can estimate a standard deviation from tables of recommended tolerances for various machine tools. Historically, most companies have consid-

ered a process with a Cp of 1 as desirable. (See Chapters 2 and 10 for more discussion of Cp.) Using that as a criterion, you can estimate a standard deviation for many manufacturing processes by finding a recommended tolerance in a handbook such as Reference 1 and dividing the tolerance by three to get a standard deviation. Table 11-1 shows some estimated standard deviations for various machining processes that we'll use for the examples in this book.

This chapter will introduce four techniques that use process standard deviations to allocate tolerances. These techniques will allow us to meet specific goals for defect rates that occur during assembly and fabrication. All four techniques should be used as design tools to assign tolerances to a drawing that will meet targeted quality goals. The choice of a particular technique will depend on the assumptions (and associated risks) with which you are comfortable. To compare the results of these analyses with the more traditional approaches, we will analyze the same problem that was used in Chapter 9. See Fig. 11-2.

Even with a statistical analysis, some assumptions need to be made. They are as follows:

- The distributions that characterize the expected ranges of each variable dimension are normal. This assumption is more important when estimating the defect rates for the components than for the assembly. If

**Table 11-1** Process standard deviations that will be used in this chapter

Process	Standard Deviation (in.)	Process	Standard Deviation (in.)
N/C end milling	.00026	JB end milling	.000105
N/C side milling	.00069	JB side milling	.000254
N/C side milling, > 6.0 in.	.00093	JB bore holes < .13 diameter	.000048
N/C drilling holes (location)	.00076	JB bore holes < .13 diameter	.000056
N/C drilling holes (diameter)	.00056	JB bore holes (location)	.000054
N/C tapped holes (depth)	.0025	JB drilling holes (location)	.000769
N/C bore/ream holes (diameter)	.00006	JB countersink (diameter)	.001821
N/C bore/ream holes (location)	.00022	JB reaming (diameter)	.000159
N/C countersink (location)	.00211	JB reaming (location)	.000433
N/C end mill parallel < 16 sq. in	.00020	JB end mill parallel < 16 sq. in.	.000090
N/C end mill parallel > 16 sq. in	.00047	JB end mill parallel > 16 sq. in.	.000232
N/C end mill flat < 16 sq. in	.00019	JB end mill flat < 16 sq. in.	.000046
N/C end mill flat > 16 sq. in	.00027	JB end mill flat > 16 sq. in.	.000132
N/C bore perpendicular < .6 deep	.00020	JB bore perpendicular < .6 deep	.000107
N/C bore perpendicular > .6 deep	.00031	JB bore perpendicular > .6 deep	.000161
Turning ID	.000127		
Turning OD	.000132	Treypan ID	.000127
Bore/ream ID	.000111	Turning lengths	.000357
Grinding, surface	.000029	Grinding, lap	.000027
Grinding, ID	.000104	Grinding, tub	.000031
Grinding, OD	.000029		

11-4 Chapter Eleven

Process	Standard Deviation (in.)	Process	Standard Deviation (in.)
Aluminum Casting		Steel Casting	
Cast up to .250	.000830	Cast up to .250	.000593
Cast up to .500	.001035	Cast up to .500	.001060
Cast up to 1.00	.001597	Cast up to 1.00	.001346
Cast up to 2.00	.002102	Cast up to 2.00	.002099
Cast up to 3.00	.002662	Cast up to 3.25	.003064
Cast up to 4.00	.003391	Cast up to 4.25	.003921
Cast up to 5.00	.003997	Cast up to 5.25	.005118
Cast up to 6.00	.004389	Cast up to 6.25	.005784
Cast up to 7.00	.005418	Cast up to 7.25	.007427
Cast up to 8.00	.006464	Cast up to 8.25	.007699
Cast up to 9.00	.006879	Cast up to 9.25	.008317
Cast up to 10.00	.008085	Cast up to 10.00	.009596
Cast up to 11.00	.008126	Cast up to 11.00	.011711
Cast over 11.00	.008725	Cast over 11.00	.011743
Cast flat < 2 sq. in.	.001543	Cast flat < 2 sq. in.	.001520
Cast flat < 4 sq. in.	.002003	Cast flat < 4 sq. in.	.002059
Cast flat < 6 sq. in.	.002860	Cast flat < 6 sq. in.	.003108
Cast flat < 8 sq. in.	.003828	Cast flat < 8 sq. in.	.004131
Cast flat < 10 sq. in.	.004534	Cast flat < 10 sq. in.	.004691
Cast flat 10+ sq. in.	.005564	Cast flat 10+ sq. in.	.005635
Cast straight < 2 in.	.001965	Cast straight < 2 in.	.002197
Cast straight < 4 in.	.004032	Cast straight < 4 in.	.004167
Cast straight < 6 in.	.004864	Cast straight < 6 in.	.005240
Cast straight < 8 in.	.007087	Cast straight < 8 in.	.006695
Cast straight < 10 in.	.007597	Cast straight < 10 in.	.007559
Cast straight over 10 in.	.009040	Cast straight over 10 in.	.009289

the distribution for the components is significantly different than a normal distribution, the estimated defect rate may be incorrect by an order of magnitude or more. Assembly distributions tend to be closer to normal as the number of components in the stack increase because of the central limit theorem (Reference 9). Therefore, the error will tend to decrease as the number of dimensions in the stack increase. How important are these errors? Usually, they don't really matter. If our estimated defect rate is high, we have a problem that we need to correct before finishing our design. If our design has a low estimated defect rate, an error of an order of magnitude is still a small number. In either case, the error is of little relevance.

- The mean of the distribution for each dimension is equal to the nominal value (the center of the tolerance range). If specific information about the mean of any dimension is known, that value should be substituted

in place of the nominal number in the dimension loop. An example where this might apply is the tendency to machine toward maximum material condition for very tightly toleranced parts.

- Each of the dimensions in the stack is statistically independent of all others. This means that the value (or change in value) of one has no effect on the value of the others. (Reference 7)

Tolerances on some dimensions, such as purchased parts, are not usually subject to change. In the following methods, their impact will be considered to act in a worst case manner. For example, if a dimension is  $3.00 \pm .01$  in., it will affect the gap as if it is really fixed at 2.09 or 3.01 with no tolerance. We choose the minimum or maximum value based on which one minimizes the gap.

### 11.4 Worst Case Allocation

In many cases, a product needs to be designed so that assembly is assured, regardless of the particular combination of dimensions within their respective tolerance ranges. It is also desirable to assign the individual tolerances in such a way that all are equally producible. The technique to accomplish this using known process standard deviations is called worst case allocation. Fig. 11-2 shows a motor assembly similar to Fig. 9-2 that we will use as an example problem to demonstrate the technique.

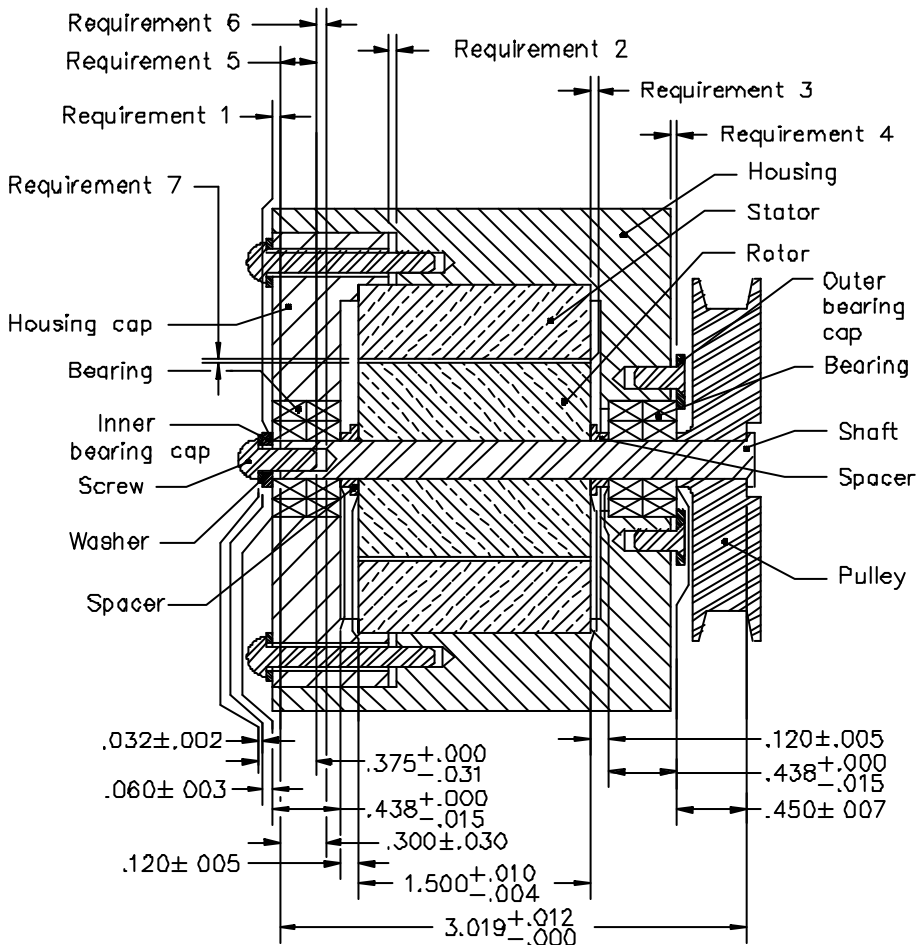

Figure 11-2 Motor assembly

11.4.1 Assign Component Dimensions

The process follows the flow chart shown in Fig. 11-3, the worst case allocation flow chart. The first step is to determine which of the dimensions in the model contribute to meeting the requirement. We identify these dimensions by using a loop diagram identical to the one shown in Fig. 9-3, which we've repeated in Fig. 11-4 for your convenience. In this case, there are 11 dimensions contributing to the result. We'll allocate tolerances to all except the ones that are considered fixed. Thus, there are five dimensions that have tolerances and six that need to be allocated. The details are shown in Table 11-2.

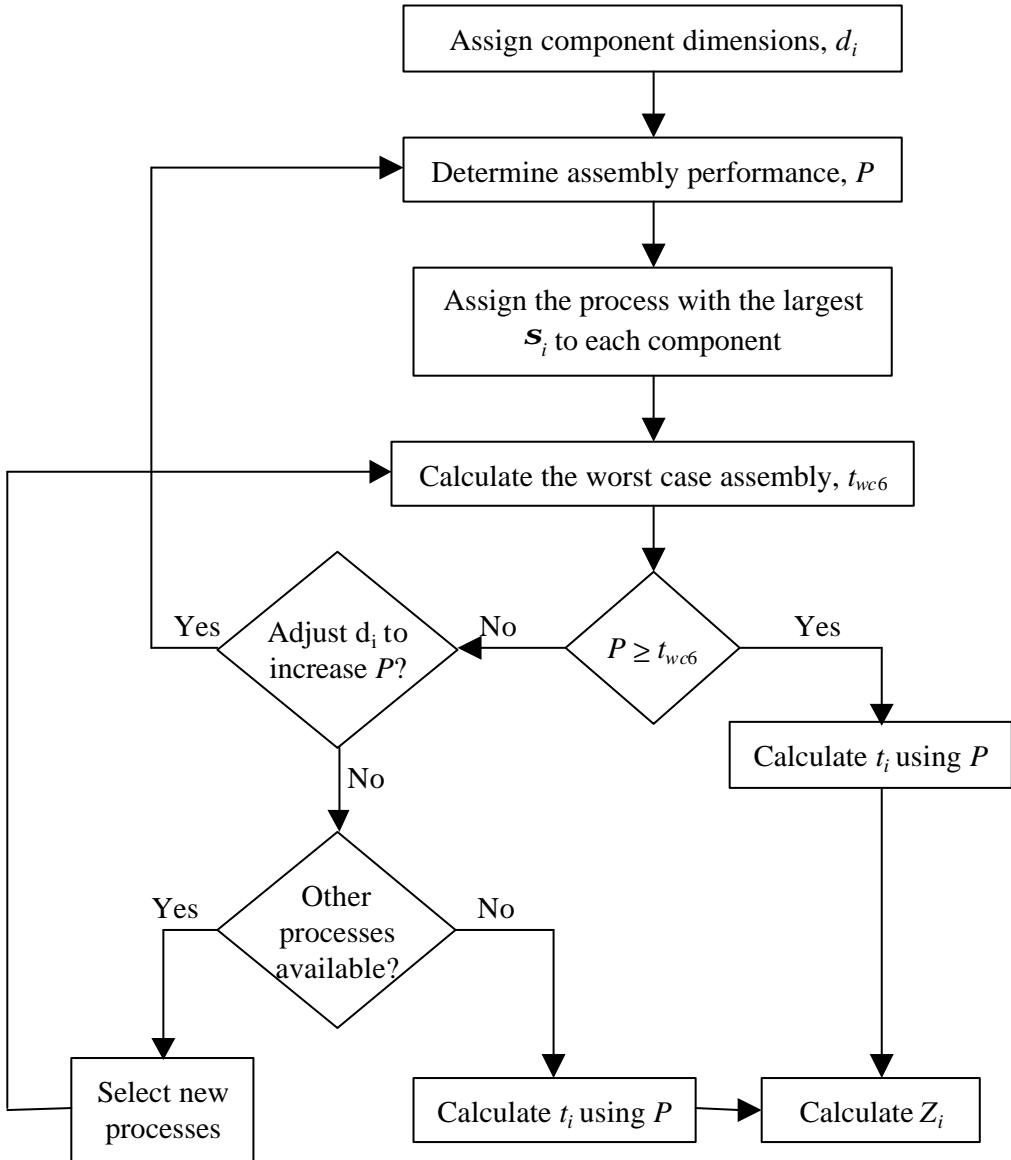

Figure 11-3 Worst case allocation flow chart

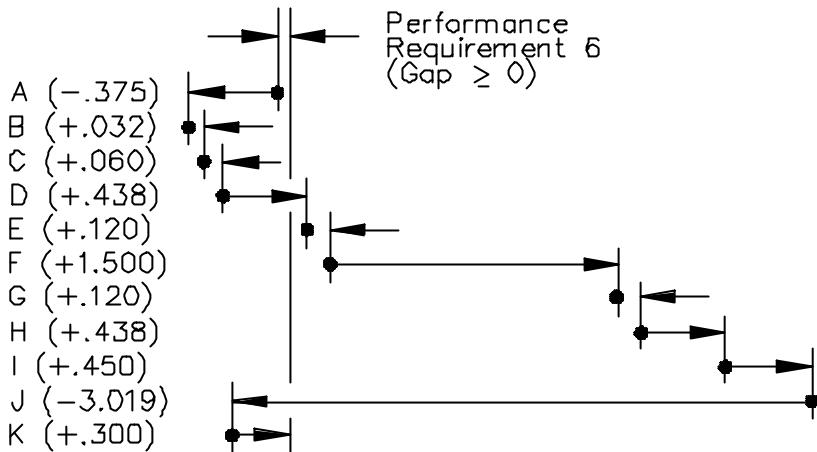

Figure 11-4 Dimension loop for Requirement 6

### 11.4.2 Determine Assembly Performance, $P$

The second step is to calculate the assembly performance,  $P$ . This is found using Eq. (11.1). While it is similar to Eq. (9.1) that was used to calculate the mean gap in Chapter 9, there are some additional terms here. The first term represents the mean gap and the result is identical to Eq. (9.1). This value is adjusted by two added terms. The first added term,  $\sum |a_j t_{jF}|$ , accounts for the effect of the fixed tolerances. In this case, we calculate the sum of the tolerances and subtract them from the mean gap. The effect is that we treat fixed tolerances as worst case. The second added term is an adjustment on the gap to account for instances where you need to keep the minimum gap greater than zero. For example, suppose we want to

Table 11-2 Data used to allocate tolerances for Requirement 6

Variable Name	Mean Dimension (in.)	Sensitivity	Fixed/ Variable	$\pm$ Tolerance (in.)	Standard Deviation (in.)	Process
A	.3595	-1	Fixed	.0155		
B	.0320	1	Fixed	.0020		
C	.0600	1	Variable		.000357	Turning length
D	.4305	1	Fixed	.0075		
E	.1200	1	Variable		.000357	Turning length
F	1.5030	1	Fixed	.0070		
G	.1200	1	Variable		.000357	Turning length
H	.4305	1	Fixed	.0075		
I	.4500	1	Variable		.00106	Steel casting up to .500
J	3.0250	-1	Variable		.000357	Turning length
K	.3000	1	Variable		.0025	N/C tapped hole depth

## 11-8 Chapter Eleven

ensure a certain ease of assembly for two parts. We may establish a minimum gap of .001 in. so they don't bind when using a manual assembly operation. Then we would set  $g_m$  to .001 in. The sum,  $P$ , is the amount that we have to allocate to the rest of the dimensions in the stack. For Requirement 6, assembly ease is not a concern, so we'll set  $g_m$  to .000 in.

$$P = \sum_{i=1}^n a_i d_i - \sum_{j=1}^p |a_j t_{jf}| - g_m \quad (11.1)$$

where

$n$  = number of independent variables (dimensions) in the stackup

$p$  = number of fixed independent dimensions in the stackup

For Requirement 6,

$$\sum_{j=1}^p |a_j t_{jf}| = |(-1).0155| + |(1).0020| + |(1).0075| + |(1).0070| + |(1).0075| = .0395 \text{ in.}$$

$$g_m = .000 \text{ in.}$$

$$P = (-1).3595 + (1).0320 + (1).0600 + (1).4305 + (1).1200 + (1)1.5030 + (1).1200 + (1).4305 \\ + (1).4500 + (-1)3.0250 + (1).3000 - .0395 - .000 \\ = .022 \text{ in.}$$

Thus, we have .022 in. to allocate to the six dimensions that do not have fixed tolerances.

### 11.4.3 Assign the Process With the Largest $S_i$ to Each Component

The next step on the flow chart in Fig. 11-3 is to choose the manufacturing process with the largest standard deviation for each component. For the allocation we are completing here, we will use the processes and data in Table 11-1. If you have data from your manufacturing facility, you should use it for the calculations. Table 11-2 shows the standard deviations selected for the components in the motor assembly that contribute to Requirement 6.

### 11.4.4 Calculate the Worst Case Assembly, $t_{wc6}$

The term  $t_{wc6}$  that is calculated in Eq. (11.2) can be thought of as the gap that would be required to meet  $6\sigma$  or another design goal.

$$t_{wc6} = 6.0 \sum_{i=1}^{n-p} |a_i S_i| \quad (11.2)$$

In the examples that follow, we'll assume the design goal is  $6\sigma$ , which is a very high-quality design. If we use the equations as written, our design will have quality levels near  $6\sigma$ . If our design goal is something less than or greater than  $6\sigma$ , we can modify Eqs. (11.2) and (11.3) by changing the 6.0 to the appropriate value that represents our goal. For example, if our goal is  $4.5\sigma$ , Eq. (11.2) becomes:

$$t_{wc6} = 4.5 \sum_{i=1}^{n-p} |a_i S_i|$$

Using the process standard deviations shown in Table 11-2,  $t_{wc6}$  for Requirement 6 is calculated below.

$$t_{wc6} = 6.0 \left( |(1) .000357| + |(1) .000357| + |(1) .000357| + |(1) .00106| + |(-1) .000357| + |(1) .0025| \right) = .0299$$

#### 11.4.5 Is $P \geq t_{wc6}$ ?

If  $P$  is smaller than  $t_{wc6}$ , the amount we have to allocate is less than what is required for a  $6\sigma$  design. If  $P$  is greater than or equal to  $t_{wc6}$ , the tolerances we can allocate will be greater than or equal to  $6\sigma$ . In our case, the former is true, so we have some decisions to make.

The first choice would be to evaluate all the dimensions and decide if any can be changed that will increase  $P$ . The amount to change any component depends on the sensitivity and design characteristics. The sensitivity tells us whether to increase or decrease the size of the dimension. (Dimensions with arrows to the right and up in the loop diagram are positive; left and down are negative.) If the dimension has a positive sensitivity, making the nominal dimension larger will make  $P$  larger. Conversely, if you increase the nominal value of a dimension with a negative sensitivity, the gap will get smaller. The amount of change in the size of the gap depends on the magnitude. Sensitivities with a magnitude of +1 or -1 will change the gap .001 in. if a dimension is changed by .001 in. Suppose we change the depth of the tapped hole from .300 in. to .310 in. Following the flow chart in Fig. 11-3, we need to recalculate  $P$ , which is now .032 in. Thus, we will exceed our design goal.

If we evaluate the design and find that we can't change any of the dimensions, a second option is to select processes that have smaller standard deviations. If some are available, we would have to recalculate  $t_{wc6}$  and compare it to  $P$ . In general, it takes relatively large changes in standard deviations to make a significant impact on  $t_{wc6}$ . This option, then, can have a considerable effect on product cost.

If we follow the flow chart in Fig. 11-3 and neither of these options are acceptable, we will have a design that does not meet our quality goal. However, it may be close enough that we can live with it. The key is the producibility of the component tolerances. If they can be economically produced, then the design is acceptable. If not, we may have to reconsider the entire design concept and devise an alternative approach. For the purposes of this example, we'll assume that design or process changes are not possible, so we have to assign the best tolerances possible. After that we can evaluate whether or not they are economical.

We'll use Eq. (11.3) to calculate the component tolerances. Looking at the terms in Eq. (11.3), we see that  $P$  and  $t_{wc6}$  will be the same for all the components. Thus, components manufactured with similar processes (equal standard deviations) will have equal tolerances. We'll have three different tolerances because we have three different standard deviations: .000357 in. for turned length, .0025 in. for tapped hole depth, and .00106 in. for the cast pulley.

$$t_i = 6.0 \left( \frac{P}{t_{wc6}} \right) s_i \quad (11.3)$$

First, for the dimensions made on a Numerical Controlled (N/C) lathe:

$$\begin{aligned} t &= 6.0 \left( \frac{.022}{.0299} \right) .000357 \\ &= .0016 \text{ in.} \end{aligned}$$

**11-10 Chapter Eleven**

For the dimensions made by casting (pulley):

$$t = 6.0 \left( \frac{.022}{.0299} \right) .00106$$

$$= .0046 \text{ in.}$$

Finally, for the tapped hole depth:

$$t = 6.0 \left( \frac{.022}{.0299} \right) .0025$$

$$= .011 \text{ in.}$$

Table 11-3 contains the final allocated tolerances.

**Table 11-3** Final allocated and fixed tolerances to meet Requirement 6

Variable Name	Mean Dimension (in.)	Fixed/ Variable	± Tolerance (in.)	Allocated ± Tolerance (in.)
A	.3595	Fixed	.0155	
B	.0320	Fixed	.0020	
C	.0600	Variable		.0016
D	.4305	Fixed	.0075	
E	.1200	Variable		.0016
F	1.5030	Fixed	.0070	
G	.1200	Variable		.0016
H	.4305	Fixed	.0075	
I	.4500	Variable		.0046
J	3.0250	Variable		.0016
K	.3000	Variable		.011

**11.4.6 Estimating Defect Rates**

We have to complete two more tasks to finish the analysis. The first will be to verify that all the dimensions with allocated tolerances are equally producible. Our definition of producibility in this case will be the estimated defect rate. Eq. (11.4) defines a term  $Z_i$  that represents the number of standard deviations (sigmas) that are between the nominal value of a dimension and the tolerance limits. If we assume that the components are produced with a process that approximates a normal distribution, then we can use some standard tables to estimate the defect rate.

$$Z_i = \frac{t_i}{s_i} \tag{11.4}$$

The method to calculate the defect rate depends on the nature of the standard deviation used and the way the data was collected. For example, suppose the standard deviation represented a sample rather than

the total population. Since we're usually interested in long-term versus short-term yields, the sample may not represent what will happen over a long period of time. We have a couple of techniques to use to adjust the calculation to account for long-term effects. The first one involves a shift in the mean; the second an inflation of the value of the standard deviation. In both cases, we'll use Eq. (11.4) and assume the component dimensions will be normally distributed.

For the dimensions that are manufactured on the N/C lathe, the tolerance is .0016 in. and the standard deviation is .000357 in. If we use the mean shift model, we'll calculate  $Z$  directly from Eq. (11.4).

$$Z_1 = \frac{.0016}{.000357} = 4.48$$

We now reduce the value of  $Z_1$  by 1.5, which is equivalent to shifting the mean by 1.5 standard deviations (Reference 5). Thus, we will look in a table of values from a standard normal distribution (see Chapter 10 Appendix) with  $Z = 4.48 - 1.5 = 2.98$ . The defect rate is equal to the area to the right of the  $T_U$  line in Fig. 11-5 that represents the component dimension tolerance limit (far right). From the  $Z$  value we just calculated, the estimated defect rate will be .0014, or the yield on this dimension will be 99.86%. Since the mean has been shifted, it is only necessary to get the value from one tail of the distribution. The other tail is very small in comparison and its effect is negligible.

When doing this calculation, we take a shortcut to simplify the technique. When we assume a mean shift of 1.5 standard deviations, we make no mention of the direction that the mean shifts. Our example (Fig. 11-5) showed the mean shifting  $+1.5\sigma$ . We could have shown it shifting  $1.5\sigma$  in the negative direction just as easily. We are actually assuming that the shift happens in both directions with an equal probability. Therefore, the complete equation could more properly be written as  $.5*.0014 + .5*.0014 = .0014$ , which is the same number as before.

The second way to adjust the defect rate estimate is to inflate the value of the standard deviation. Usually, the factor chosen is based on data from statistical process control and is between 33% and 50%. We'll use 33% here. The new value for the standard deviation is:

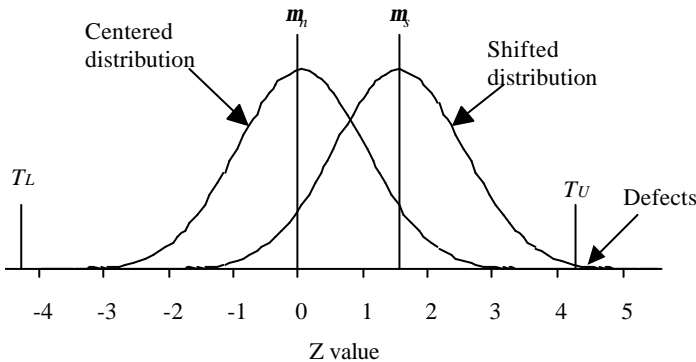

**Figure 11-5** Effect of shifting the mean of a normal distribution to the right.  $T_L$  is the lower tolerance limit,  $T_U$  the upper tolerance limit,  $m_1$  is the unshifted mean, and  $m_2$  is the shifted mean

$$.000357(1.33) = .000475 \text{ in.}$$

and

$$Z_1 = \frac{.0016}{.000475} = 3.37$$

We can look up Z from a table of tail area of a normal distribution (see Appendix of Chapter 10). The estimated defect rate is .00075 or the yield is 99.92%. Note that in this case, we double the value from the table so that both tails of the distribution are included. This is necessary because, as shown in Fig. 11-6, the area in both tails is the same and one is not negligible compared to the other.

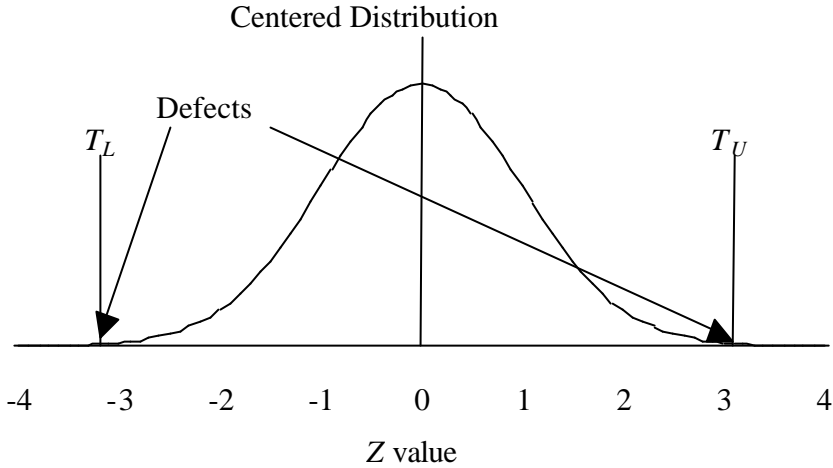

Figure 11-6 Centered normal distribution. Both tails are significant.

Normally, we don't expect the answer to be the same for both methods. The one you choose should be based on your knowledge about the manufacturing process and the data collected.

The tolerances for the pulley and the tapped hole depth are determined in similar manner and are .0046 in. and .011 in. respectively. If we follow the same process as above, we can verify that the estimated defect rates for these two dimensions are identical to the lathe parts and they are equally producible.

### 11.4.7 Verification

Finally, we should verify that the tolerances will meet Requirement 6. We'll use Eq. (9.2) to ensure that we can assemble the components as desired.

$$t_{wc} = \sum_{i=1}^n |a_i t_i|$$

$$\begin{aligned} \sum_{i=1}^n |a_i t_i| &= |(-1) .0155| + |(1) .0020| + |(1) .0016| + |(1) .0075| + |(1) .0016| + |(1) .0070| + |(1) .0016| + |(1) .0075| \\ &\quad + |(1) .0046| + |(-1) .0016| + |(1) .011| \\ &= .0615 \text{ in.} \end{aligned}$$

Recall that Requirement 6 is a minimum gap of zero. Using the worst case allocation technique, we were able to quickly assign tolerances so that the minimum gap is .0615 in. - .0615 in. = .0000 in. This meets our performance requirement with a single pass through the process. While the tolerances added up exactly to the worst case requirement in this case, they often do not because of rounding errors.

### 11.4.8 Adjustments to Meet Quality Goals

In the previous sections, we quickly allocated tolerances that met Requirement 6, but without meeting our quality goal of 6 $\sigma$  producibility. We briefly discussed the other options presented by the flow chart in Fig. 11-3. The first and most desirable choice is to modify the nominal component dimensions so that  $P$  is greater than or equal to  $t_{wc6}$ . It is clear that changing any combination of the dimensions so that  $P$  is increased by  $t_{wc6} - P = .0299$  in.  $- .022$  in.  $= .0079$  in. will accomplish the task. We can look at Table 11-2 to give us guidance about how to change component dimensions. The sensitivity for each dimension is the key factor. Increasing a dimension with a positive sensitivity will increase  $P$ , while increasing a dimension with a negative sensitivity will make  $P$  smaller. Also, it is generally not practical to change any of the dimensions with fixed tolerances, since the dimension is usually fixed as well. Therefore, we can increase  $P$  by changing the thickness of the inner bearing cap (component dimension C) from .060 in. to .068 in. We can easily calculate a new value of  $P$  using Eq. (11.1) and find it is now .030 in. Since  $P$  is now greater than  $t_{wc6}$ , we can allocate tolerances that meet our quality and assembly goal simultaneously.

It would be a less desirable choice if we decided to try to change our processes to try to make  $t_{wc6}$  smaller. Even though the mathematics of the problem don't seem to steer us away from this option, reality does. The first problem is that our unit costs would rise as we move to more precise processes. Second, it usually takes many process changes to make a significant change in  $t_{wc6}$ , compounding the cost penalty. If we end up in a situation where we can't alter  $P$ , it is often better to either review the entire design concept and consider other approaches to achieving the design's objective or accept the lower assembly producibility from our original allocation.

A third option we could consider is a statistical allocation technique that we will discuss in later sections of this chapter.

### 11.4.9 Worst Case Allocation Summary

Let's recap the important points about worst case allocation.

- Tolerances will combine to meet assembly requirements at worst case.
- Tolerances are allocated with a minimum of iteration.
- Worst case allocation will lead to tolerances that are equally producible, based on estimated defect rates.
- Tolerances that are manufactured using similar manufacturing processes will be assigned the same values.
- Choosing the most economical processes (largest standard deviation) first can help lead to the lowest cost design.
- Data from the manufacturing floor will lead to predictable quality levels.
- Since we are performing a worst case analysis, the predicted assembly yield is 100%.

## 11.5 Statistical Allocation

Although worst case allocation will lead to a design with each dimension equally producible, it can cause tighter tolerances than are necessary. In a manner similar to what is used for traditional RSS analysis, we will statistically combine standard deviations to determine an expected variation of the assembly, which will allow a prediction of the number of defects that may occur. Then we will allocate tolerances to each of the component dimensions so that each of them is equally producible and will be larger than we achieved with the worst case allocation model.

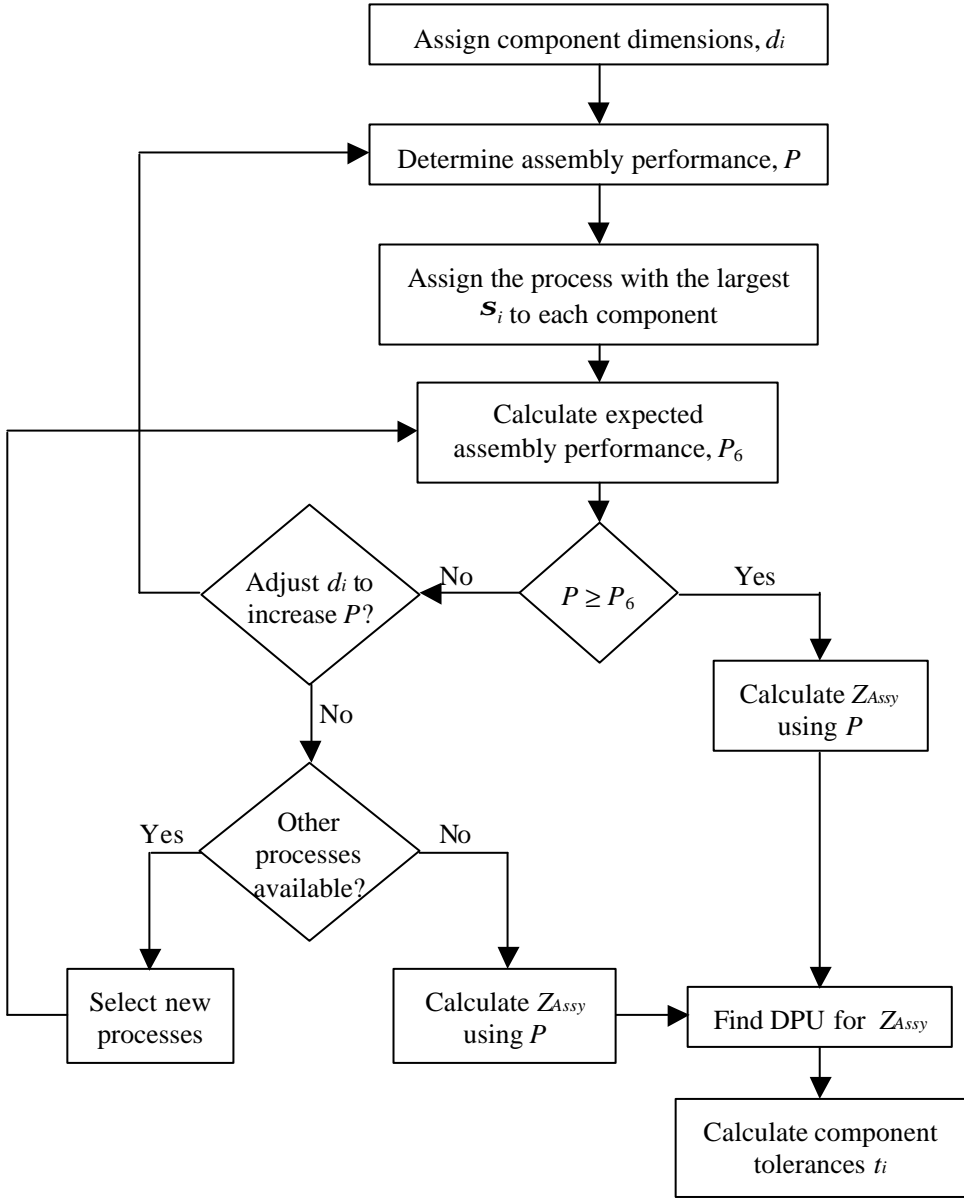

Figure 11-7 Statistical allocation flow chart

Looking at the statistical allocation flow chart shown in Fig. 11-7, there is an obvious similarity to the one used for worst case allocation. The differences are primarily in the equations used to calculate the terms.

### 11.5.1 Calculating Assembly Variation and Defect Rate

In Chapter 9, Eq. (9.8) was developed during derivation of the RSS technique. It shows how standard deviations of each of the dimensions in a tolerance analysis can be combined to yield a standard deviation of the gap.

$$s_{\text{Assy}} = \sqrt{\sum_{i=1}^n (a_i s_i)^2} \quad (11.5)$$

The use of Eq. (11.5) requires that all the variables (dimensions) be statistically independent. Two (or more) variables are considered statistically independent if the value (or change in value) of one has no effect on the value of the other(s). (Reference 8)

Eq. (11.5) gives us the ability to estimate the defect rate at the assembly level in the same manner that we calculated it for the component dimensions with worst case allocation. The standard deviations (used in the equation are the same ones from Table 11-1 that we used during worst case allocation. Thus,

$$Z_{\text{Assy}} = \frac{P}{s_{\text{Assy}}} \quad (11.6)$$

From  $Z_{\text{Assy}}$  we can find the estimated assembly defect rate using the same techniques introduced in section 11.4.6.

### 11.5.2 First Steps in Statistical Allocation

Referring to the process flow chart in Fig. 11-7, the first three steps are identical to the ones for worst case allocation. For Requirement 6, the component dimensions,  $P$ , and standard deviations are the same ones we used in sections 11.4 through 11.4.7 and shown in Table 11-2. Recall that  $P$  is the clearance between the end of the screw and the bottom of the tapped hole and that it has a value of .022 in. We determined the value for  $P$  using Eq. (11.1) and it consists of the nominal gap that is reduced by the effect of fixed tolerances and the minimum clearance requirement.

### 11.5.3 Calculate Expected Assembly Performance, $P_6$

The next step is slightly different than for worst case allocation, but the meaning is similar. Like  $t_{\text{wc6}}$ ,  $P_6$  can be thought of as the goal to meet a particular assembly defect objective. When using Eq. (11.7) below, the goal would be  $6\sigma$ .

$$P_6 = 6.0 s_{\text{Assy}} \quad (11.7)$$

Inserting the values from Table 11-2 into Eqs. (11.5) and (11.7) for Requirement 6,

$$s_{\text{Assy}} = \sqrt{(1(.000357))^2 + (1(.000357))^2 + (1(.000357))^2 + (1(.00106))^2 + (-1(.000357))^2 + (1(.0025))^2} \\ = .00281 \text{ in.}$$

and

$$P_6 = 6.0(.00281) \\ = .01685 \text{ in}$$

### 11.5.4 Is $P \geq P_6$ ?

If  $P$  is smaller than  $P_6$ , the amount we have to allocate is less than what is required for both the assembly and components to be a  $6\sigma$  design. Conversely, if  $P$  is greater than or equal to  $P_6$ , we can allocate tolerances so that the assembly and all the component dimensions that contribute to Requirement 6 will be greater than or equal to  $6\sigma$ . In our case, the former is true, so we can allocate the tolerances to each of the component dimensions.

Before we allocate the tolerances, though, let's evaluate the expected assembly defect rate. Once again, the standard deviations we are using are considered short-term values, so the calculated standard deviation for the assembly is a short-term value. Thus, we'll have to adjust it so we can estimate the assembly defect rate we will see over an extended period of time. We'll use the same two techniques as in section 11.4.6 along with Eq. (11.6).

Using the mean shift model, as shown in Fig. 11-5,

$$\begin{aligned} Z_{\text{Assy}} &= \frac{.022}{.00281} \\ &= 7.83 \end{aligned}$$

From a table of the standard normal distribution with  $Z = Z_{\text{Assy}} - 1.5 = 6.33$ , the tail area in the normal distribution is **1.8(10)**. Before we can estimate the assembly defect rate, we need to think about the condition where acceptable assembly occurs. When we calculated defect rates for the component dimensions using the worst case allocation technique, we needed to be concerned about parts that were manufactured both above and below the tolerance limits. For the assembly we are evaluating, we are concerned if the gap becomes too small, but larger gaps are not expected to cause any problems. Thus, we won't consider large gaps to be defects and the estimated defect rate will be half the area of the tail area, or  $9.0(10^{-11})$ .

If we choose to inflate the standard deviation, the same factor of 33% that we used earlier is appropriate. The adjusted standard deviation is:

$$.00281(1.33) = .00374 \text{ in.}$$

and

$$\begin{aligned} Z_{\text{Assy}} &= \frac{.022}{.00374} \\ &= 5.88 \end{aligned}$$

Again looking in a table of areas from a standard normal distribution, we find that the area beyond the value of 5.88 is  $2.5(10^{-9})$ . Since this value is for a unilateral tail area and we are only concerned with one side of the distribution, there is no need to double the value. Therefore, the estimated assembly defect rate using the inflation technique is  $2.5(10^{-9})$ .

Regardless of the method we use to transform our values from short term to long term, there is very little chance of a defect occurring with this assembly.

When we use the normal distribution to estimate assembly defect rates, there are a couple of assumptions we're making that are worth noting. First, we are assuming the assembly distribution is indeed normal. If each of the component distributions is normal, then the assembly distribution will be normal for these kinds of problems (linear combinations). If some of the component distributions are non-normal, then the assembly distribution is also non-normal. The error that results may or may not be significant, and is relatively difficult to determine through direct analytical means. (Reference 4) A commonsense

approach will help us decide if it is important or not. If we have a situation like the one that we've just evaluated, our estimation errors could be incorrect by two or three orders of magnitude and we would still have very low defect rates. In cases similar to this, it makes little difference whether the distribution is normal or not; we still have a very slight chance that an assembly will be defective. If the defect rate is much higher, the error caused by the shape of the distribution may become significant. In these cases, a Monte Carlo simulation (Reference 2) or a second-order technique (Reference 4) can be used to find a better estimate of the shape of the assembly distribution and the defect rate.

A second assumption we make is that there is no inspection of component parts. When we inspect parts, we rework or discard the defects, and the final distribution might look like Fig. 11-8 instead of a full normal distribution. While this looks pretty significant, it is not usually so. The distribution shown in Fig. 11-8 is truncated at about  $\pm 2\sigma$ . Parts with such a high defect rate are not desirable in production. If we suspect that this will occur, a Monte Carlo technique is a good alternative to use to estimate defect rates. We could also consider a worst case allocation approach. In most cases, the effect of the truncation on the assembly defect rate is negligible and ignoring it immensely simplifies the calculations.

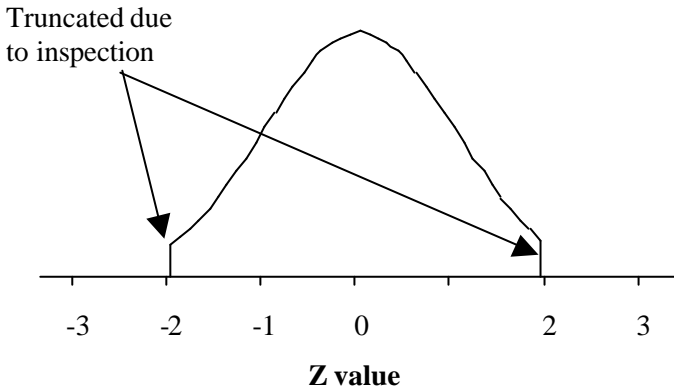

**Figure 11-8** Normal distribution that has been truncated due to inspection

### 11.5.5 Allocating Tolerances

There are two different approaches we can use to allocate the tolerances. The first, statistical allocation, is to allocate tolerances to each of the component dimensions to meet a specific quality goal. For example, if our goal is  $6\sigma$ , we would use Eq. (11.8), which allocates tolerances to each dimension that are 6 times the standard deviation.

$$t_i = 6.0s_i \tag{11.8}$$

With this technique, the tolerance for the dimensions created by turning on an N/C lathe is

$$t = 6.0 ( .000357 ) \\ = .0021 \text{ in.}$$

For the dimensions made by casting (pulley):

$$t = 6.0 ( .00106 ) \\ = .0064 \text{ in.}$$

Finally, for the tapped hole depth:

$$t = 6.0 ( .0025 ) \\ = .015 \text{ in.}$$

The results for all the dimensions are shown in Table 11-4.

**Table 11-4** Fixed and statistically allocated tolerances for Requirement 6

Variable Name	Mean Dimension (in.)	Fixed/ Variable	± Tolerance (in.)	Statistically Allocated ± Tolerance (in.)
A	.3595	Fixed	.0155	
B	.0320	Fixed	.0020	
C	.0600	Variable		.0021
D	.4305	Fixed	.0075	
E	.1200	Variable		.0021
F	.5030	Fixed	.0070	
G	.1200	Variable		.0021
H	.4305	Fixed	.0075	
I	.4500	Variable		.0064
J	3.0250	Variable		.0021
K	.3000	Variable		.015

A second method for statistically allocating tolerances, RSS allocation, would give us component tolerances that have the same estimated defect rate as the assembly.

$$t_i = Z_{Assy} s_i \tag{11.9}$$

We can also express the same relationship as

$$t_i = \frac{P}{s_{Assy}} s_i \tag{11.10}$$

or

$$t_i = \left( \frac{P}{\sqrt{\sum_{j=1}^n (a_j s_j)^2}} \right) s_i$$

Since we've already calculated  $Z_{Assy}$ , we'll use the simplest of these equations, Eq. (11.9), to calculate tolerances.

First, for the dimensions made on an N/C lathe:

$$t = 7.83 (.000357) = .0028 \text{ in.}$$

For the dimensions made by casting (pulley):

$$t = 7.83 (.00106) = .0083 \text{ in.}$$

Finally, for the tapped hole depth:

$$t = 7.83(.0025) = .0196 \text{ in.}$$

The tabulated results for the RSS allocation method are shown in Table 11-5. When we compare the results in Table 11-4 that were calculated with the first method, we see the tolerances are larger. This is a consequence of magnitude of the performance requirement, represented here by  $P$ , compared to a specific goal for defect rate. In this case,  $P$  is larger than required to meet a specific defect goal (e.g.,  $6\sigma$  that is represented by  $P_6$ ). Therefore, restricting the allocated tolerance to the  $6\sigma$  goal makes it smaller than if it is calculated based on the assembly defect rate. On the other hand, when  $P$  is smaller than  $P_6$  the allocated tolerance will be greater for the first method than the second. The assembly defect rate is the same for both cases because we are assuming there is no parts screening or inspection at the component level.

**Table 11-5** Fixed and RSS allocated tolerances for Requirement 6

Variable Name	Mean Dimension (in.)	Fixed/ Variable	$\pm$ Tolerance (in.)	RSS Allocated $\pm$ Tolerance (in.)
A	.3595	F	.0155	
B	.0320	F	.0020	
C	.0600	V		.0028
D	.4305	F	.0075	
E	.1200	V		.0028
F	1.5030	F	.0070	
G	.1200	V		.0028
H	.4305	F	.0075	
I	.4500	V		.0083
J	3.0250	V		.0028
K	.3000	V		.0197

If we use RSS allocation, the calculated component tolerances will equal  $P$  when combined using the RSS analysis from Chapter 9, Eq. (9.11).

$$t_{Assy} = \sqrt{.0028^2 + .0028^2 + .0028^2 + .0083^2 + .0028^2 + .0197^2} = .022 \text{ in.}$$

We didn't fully discuss the options on the flow chart in Fig. 11-7 that we would explore if  $P$  was less than  $P_6$ . They are the same as with worst case allocation. The first choice would be to modify one or more of the component dimensions so that  $P$  is greater than or equal to  $P_6$ . If this is not an option, a more costly alternative is to select different processes with smaller standard deviations. Finally, if both of these are impractical or prohibitively expensive, the design concept can be re-evaluated.

### 11.5.6 Statistical Allocation Summary

Let's recap the important points about these two statistical allocation techniques.

- Tolerances allocated using the statistical techniques are larger than the ones allocated with the worst case technique.
- Predicting assembly quality quantifies the risk that is being taken with a statistical allocation.
- Tolerances are allocated to take advantage of the statistical nature of manufacturing processes.
- Tolerances are allocated with a minimum of iteration.
- Statistical allocation will lead to tolerances that will meet specific goals for defect rate.
- RSS allocation will lead to tolerances that will combine, using the RSS analysis technique, to meet the assembly requirement,
- Tolerances that are manufactured using similar manufacturing processes will be assigned the same values.
- Choosing the most economical processes (largest standard deviation) first can help lead to the lowest cost design.
- Data from the manufacturing floor will lead to predictable quality levels.

### 11.6 Dynamic RSS Allocation

The next two techniques we'll investigate are modifications of Motorola's dynamic RSS and static RSS methods from Reference 7. Both follow the flow chart of Fig. 11-7, so we'll highlight the differences instead of rigorously following the chart. The primary difference is the way that  $P_6$  is calculated. We will allocate tolerances in a manner similar to the RSS allocation technique.

Motorola's equation for dynamic RSS is repeated below:

$$Z_F = \frac{\sum_{i=1}^n N_i V_i B_i - F}{\sqrt{\sum_{i=1}^n \left( \frac{T_i B_i}{3Cpk_i} \right)^2}} \tag{11.11}$$

~~Let's relate these terms to the same ones we've been using.~~ First,  $Z_i$  is the same as  $Z_{Assy}$ ,  $V_i$  is +1 or -1 depending on the direction of the arrow in the loop diagram and  $B_i$  is the magnitude of the sensitivity. Combined,  $V_i B_i$  is equal to  $a_i$ ,  $N_i$  is the same as  $d_i$ , and  $F$  is  $g_m$ .

Now let's look at the denominator. Harry and Stewart derive this in Reference 6 by defining a term

$$s_{adj} = \frac{T}{3Cpk} \tag{11.12}$$

where Cpk is a capability index commonly used in statistical process control. We'll use the definition of Cpk and a second index, Cp, to define a convenient way to use  $s_{adj}$ . (See Chapters 2 and 10 for more explanations about Cp and Cpk.) The equations defining Cp and Cpk are:

$$Cp = \frac{USL - LSL}{6s} \tag{11.13}$$

where  $USL$  is the maximum allowable size of a feature and  $LSL$  is the minimum allowable size. Therefore,  $USL - LSL = 2T$ .

$$C_{pk} = C_p(1 - k) \quad (11.14)$$

Combining equations (11.12), (11.13), and (11.14),

$$\frac{USL - LSL}{6s} (1 - k) = \frac{T}{3s_{adj}} \quad (11.15)$$

Whenever we do a statistical analysis or allocation, the tolerance must be equal bilateral as explained in Chapter 9. Thus,  $USL - LSL = 2T$ . Substituting into Eq. (11.15) and simplifying gives us

$$s_{adj} = \frac{s}{(1 - k)} \quad (11.16)$$

The adjusted value of the standard deviation in Eq. (11.16) includes the transformation from a short-term value to a long-term one. Thus, it is similar to the adjustments we made to the standard deviation in section 11.4.6. The way we inflated the standard deviation in section 11.4.6 was by multiplying it by a factor that was between 1.33 and 1.50.

Substituting all these terms into Eq. (11.11) and recalling that  $V_i$  is either +1 or -1 gives us

$$Z_{Assy} = \frac{\sum_{i=1}^n a_i d_i - g_m}{\sqrt{\sum_{i=1}^n \left[ a_i \left( \frac{1}{1 - k_i} \right) s_i \right]^2}} \quad (11.17)$$

This equation is beginning to look very similar to the statistical allocation model from section 11.5 through 11.5.6. The primary difference is that the standard deviations from Table 11-1 are adjusted by an inflation factor,  $\frac{1}{(1 - k)}$ , prior to calculating the assembly standard deviation. Eq. (11.17) also does not account for the effect of fixed tolerances, which can be easily incorporated by subtracting them from the numerator. The equation is now

$$Z_{Assy} = \frac{\sum_{i=1}^n a_i d_i - \sum_{j=1}^p |a_j t_{jf}| - g_m}{\sqrt{\sum_{i=1}^n \left[ a_i \left( \frac{1}{1 - k_i} \right) s_i \right]^2}} \quad (11.18)$$

Comparing the numerator of Eq. (11.18) to Eq. (11.1), we find that it is identical to  $P$ . Simplifying,

$$Z_{Assy} = \frac{P}{\sqrt{\sum_{i=1}^n \left[ a_i \left( \frac{1}{1 - k_i} \right) s_i \right]^2}}$$

For Requirement 6,  $P$  is .022 in. We'll use the values of  $\frac{1}{(1 - k)}$  from Table 11-6 for each dimension.

We'll also use the same values for the standard deviations for the component dimensions as before. From Eq. (11.14) we see that the values to use for  $(1 - k)$  are available from SPC data or we can make estimates based on process knowledge.

**Table 11-6** Standard deviation inflation factors and DRSS allocated tolerances for Requirement 6

Variable Name	Mean Dimension (in.)	$\frac{1}{(1-k)}$	DRSS Allocated $\pm$ Tolerance (in.)
A	.3595		
B	.0320		
C	.0600	1.05	.0025
D	.4305		
E	.1200	1.22	.0029
F	1.5030		
G	.1200	1.13	.0027
H	.4305		
I	.4500	1.27	.0088
J	3.0250	1.33	.0031
K	.3000	1.18	.0195

The denominator is the standard deviation of the assembly. Since it is calculated using different assumptions than previously, we'll call it  $s_{D_{Assy}}$ .

$$s_{D_{Assy}} = \sqrt{(1((1.05).000357))^2 + (1((1.22).000357))^2 + (1((1.13).000357))^2 + (1((1.27).00106))^2 + (-1((1.33).000357))^2 + (1((1.18).0025))^2} \tag{11.19}$$

$$= .00335 \text{ in.}$$

We'll find  $P_6$  by modifying Eq. (11.7), renaming the term  $P_{D6}$ .

$$P_{D6} = 4.5s_{D_{Assy}}$$

$$= 4.5(.00335)$$

$$= .0151$$

We changed the 6.0 to 4.5 because the former value is based on short-term standard deviations. Since the value of  $s_{D_{Assy}}$  calculated in Eq. (11.19) is based on long-term effects, it would be inappropriate to include them again when calculating  $P_{D6}$ . Since  $P \geq P_{D6}$ , we can follow the flow chart of Fig. 11-7 and calculate  $Z_{Assy}$ .

$$Z_{Assy} = \frac{0.022}{0.00335}$$

$$= 6.57$$

Remember, we adjusted the standard deviations for the components before calculating  $s_{Assy}$ , so there is no need to account for long-term effects by reducing the value of  $Z_{Assy}$  to simulate a  $1.5\sigma$  shift or to

multiply  $s_{Assy}$  by an adjustment factor. Therefore, we estimate the assembly defect rate from  $Z_{Assy}$  by finding 6.57 in the table for tail areas of a standard normal distribution. Thus, the estimated defect rate is  $4.1(10^{-11})$ . Next we'll allocate tolerances by modifying Eq. (11.10).

$$t_i = \frac{P}{s_{DAssy}} \left( \frac{1}{1 - k_i} \right) s_i$$

For dimension C, which is made on an N/C lathe:

$$\begin{aligned} t_C &= 6.57 (1.05) (.000357) \\ &= .0025 \text{ in.} \end{aligned}$$

The tolerances for the remaining dimensions are calculated similarly and shown in Table 11-6. Comparing the tolerances calculated by the DRSS allocation method and RSS allocation shows that some are larger with one method and some with the other. This is because we chose different values of  $k$  for each dimension. Had we chosen identical values of  $k$  for each dimension, use of the DRSS method would have given the same tolerances that we calculated using RSS allocation.

Once again, we can easily confirm that the tolerances will equal  $P$  if we combine them using the RSS analysis from Chapter 9, Eq. (9.11).

$$\begin{aligned} t_{Assy} &= \sqrt{.0025^2 + .0029^2 + .0027^2 + .0088^2 + .0031^2 + .0195^2} \\ &= .022 \text{ in.} \end{aligned}$$

## 11.7 Static RSS Analysis

A second technique from Reference 6 is called static RSS analysis. We can't use this technique to directly allocate tolerances, but we can use it to make another estimate of assembly defect rates. The concept behind Motorola's static RSS technique is to assume a mean shift on each component dimension that is equal to 1.5 standard deviations. Further, the shift will occur in the direction that will be most likely to cause an interference or a failure to meet the requirement. For example, the  $1.5\sigma$  shift for .450 dimension has the effect of reducing its mean value to .4484 ( $.450 - 1.5(.00106)$ ), which makes the gap smaller. The easiest way to implement this approach is to define a new parameter,  $P_{SRSS}$ , as follows:

$$P_{SRSS} = \sum_{i=1}^n a_i d_i - \sum_{j=1}^p |a_j t_{jf}| - g_m - 1.5 \sum_{q=1}^{n-p} s_q$$

$P_{SRSS}$  will be used to calculate  $Z_{Assy}$  and estimate the assembly defect rate.

Let's calculate  $P_{SRSS}$ . Comparing the first three terms to Eq. (11.1), we see they are equal to  $P$ , or .022 in. The fourth term is

$$\begin{aligned} 1.5 \sum_{q=1}^{n-p} s_q &= (1.5)(.000357 + .000357 + .000357 + .00106 + .000357 + .0025) \\ &= .0075 \end{aligned}$$

Now it is easy to calculate  $P_{SRSS}$ .

$$\begin{aligned} P_{SRSS} &= .022 - .0075 \\ &= .0145 \end{aligned}$$

## 11-24 Chapter Eleven

Now we calculate  $Z_{Assy}$  using  $P_{SRSS}$ , using Eq. (11.6) with  $P_{SRSS}$  in place of  $P$ .

$$\begin{aligned} Z_{Assy} &= \frac{P_{SRSS}}{S_{Assy}} \\ &= \frac{.0145}{.00281} \\ &= 5.16 \end{aligned}$$

We can estimate the assembly defect rate by looking in a table of areas for the tail of a normal distribution in the same manner as before. For 5.16, the area in one tail, and thus the estimated assembly defect rate is  $1.31(10^{-7})$ .

### 11.8 Comparison of the Techniques

For educational purposes, we need to compare the results of the four allocation techniques (Table 11-7). The smallest tolerances result when we use worst case allocation. When we use worst case allocation, we eliminate the risk of assembly defects occurring. Sometimes this may be worthwhile, but in this case it's probably not. Each of the other three defect estimation techniques shows a very low probability of a defect occurring. The difference in the assembly defect rates is the benefit of worst case allocation. The penalty is component parts that are more difficult to produce. In our example, the tolerances for the RSS allocation technique are almost twice as large as for the worst case allocation. The benefit for worst case is that we eliminate a  $6.0(10^{-11})$  probability of a defect occurring. As you can see, it's not a very large benefit in this case.

**Table 11-7** Comparison of the allocated tolerances for Requirement 6

Variable Name	Mean Dimension (in.)	Worst Case Allocated $\pm$ Tolerance (in.)	Statistically Allocated $\pm$ Tolerance (in.)	RSS Allocated $\pm$ Tolerance (in.)	DRSS Allocated $\pm$ Tolerance (in.)
C	.0600	.0016	.0021	.0028	.0025
E	.1200	.0016	.0021	.0028	.0029
G	.1200	.0016	.0021	.0028	.0027
I	.4500	.0046	.0064	.0083	.0088
J	3.0250	.0016	.0021	.0028	.0031
K	.3000	.011	.015	.0197	.0195
Assembly defect rate		.00	$9.0(10^{-11})$	$9.0(10^{-11})$	$4.1(10^{-11})$

Are there times when it makes sense to use worst case allocation? Absolutely! If there are less than four dimensions that contribute to a tolerance stack, it is often better. First, the difference between tolerances allocated by worst case and statistical techniques is smaller with fewer dimensions. Also, the effect of some of the assumptions is greater with fewer dimensions. For example, suppose that some of the mean values are not located at nominal. If there are a large number of dimensions in the stack, they will tend to balance out. If there are only a few, they might not, and there can be a significant effect on assembly producibility.

Another case where worst case might be justified is when safety is involved. Depending on the consequences of an assembly failure, we may not be able to afford even a small probability of a defect.

In most cases, the benefits (larger tolerances) of either statistical, RSS or DRSS allocation will outweigh the risk of an assembly defect. In fact, by estimating the assembly defect rate, we can make a decision with each of the three about whether the risk of a defect is acceptable. If it is not, we can evaluate the design at worst case, or make some change in the design concept to alleviate the problem.

### 11.9 Communication of Requirements

Ideally, if we assign a tolerance using a technique such as statistical allocation, we can notify the fabrication shop and the manufacturing process could be appropriately controlled. In the past, there has been no mechanism to use on an engineering drawing to communicate the assumptions made when assigning a tolerance to a dimension. This can lead to unexpected defects if the manufacturing shop does not treat a statistical tolerance appropriately.

A way to communicate statistical design intent is with the  $\langle \overline{ST} \rangle$  symbol that is available within ASME Y14.5M-1994 (Reference 10). Examples of statistical tolerances on drawings are shown in Fig. 11-9.

In Fig. 11-9 (a) and (c), the  $\langle \overline{ST} \rangle$  symbol designates the dimension has a tolerance that was statistically allocated. In addition to the symbol, a note is required. Although the exact wording of the note is not specified in the standard, one possibility suggested in ASME 14.5M-1994 is: “Features identified as statistically toleranced  $\langle \overline{ST} \rangle$  shall be produced with statistical process controls.”

If there is a possibility that the parts will not be produced with SPC, the designer may choose to tolerance the dimensions as shown in Fig. 11-9 (b). This method gives the manufacturing shop an option to inspect at smaller limits if SPC is not used. In this case, the standard suggests the note might read: “Features identified as statistically toleranced  $\langle \overline{ST} \rangle$  shall be produced with statistical process controls or to the more restrictive arithmetic limits.” The actual wording of the note is at the user’s discretion.

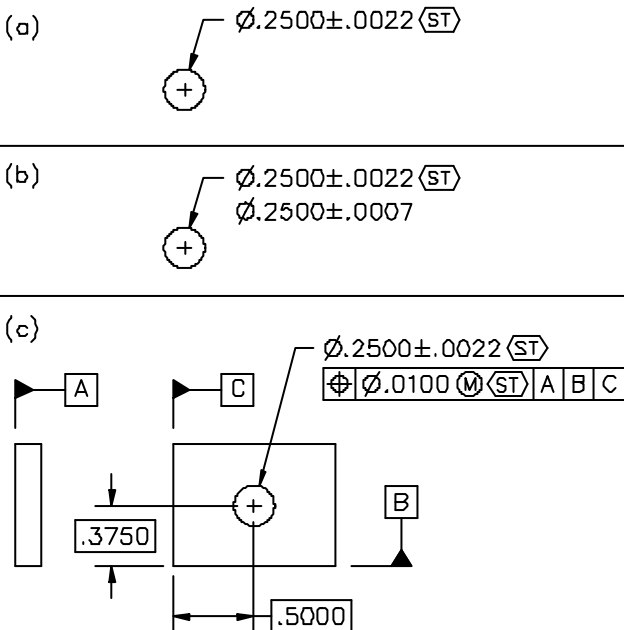

**Figure 11-9** Three options for designating a statistically derived tolerance on an engineering drawing

### 11.10 Summary

Table 11-7 shows a comparison between worst case, statistical RSS, and DRSS allocation. As with the classical models, the worst case allocation method yields the smallest tolerances, and is the more conservative design. With worst case allocation, we don't make any prediction about defect rate, because it is assumed that parts screening will eliminate any possibility of a defect (not always the case).

We need detailed information about the expected manufacturing process for all of the allocation models. The best data is from our own operations. If none is available, then we can make estimates from recommended tolerance tables or use Table 11-1 in this chapter. The use of any of these techniques will have equal validity within the limitations of the applicable assumptions.

When comparing traditional techniques with the ones presented in this chapter, the primary difference between them is the amount of knowledge used to establish tolerances. In traditional worst case analyses, for example, we make decisions based on opinions about producibility. However, worst case allocation assigns tolerances that are equally producible based on process standard deviations. Clearly, the second method is more likely to produce products that will meet predictable quality levels.

Similarly, a comparison between traditional RSS and statistical, RSS or DRSS allocation reveals little difference in the basic principles. However, the allocation models overcome many of the assumptions that are inherent in RSS. In addition, they provide an estimate of assembly defect rates.

One requirement of the statistical, RSS or DRSS allocation techniques is that the manufacturing operations understand the assumptions that were made during design. This will ensure that the choice of process standard deviations used during design will be consistent with the method chosen to fabricate the parts. Perhaps the best way to accomplish this will be the  $\boxed{\text{ST}}$  symbol that is referenced in ASME Y14.5 M - 1994.

The question could be asked about whether it is ever desirable to use the traditional methods. There might be an occasional situation where all the tolerances being analyzed are purchased parts, or otherwise not under the design engineer's control. This situation is very rare. The techniques presented in this chapter are much better approaches because they take advantage of process standard deviations that have not been previously available, and eliminate the most dangerous of the assumptions inherent in the traditional methods.

### 11.11 Abbreviations

Variable	Definition
$a_i, a_j, V_i B_i$	sensitivity factor that defines the direction and magnitude for the <i>i</i> th, <i>j</i> th and <i>n</i> th dimension. In a one-dimensional stack, this is usually +1 or -1. Sometimes, it may be +.5 or -.5 if a radius is the contributing factor for a diameter called out on a drawing.
$d_i, N_i$	mean dimension of the <i>i</i> th component in the stack.
$g_m, F$	minimum gap required for acceptable performance
$n$	number of independent dimensions in the stackup
$p$	number of independent fixed dimensions in the stackup
$P$	nominal gap that is available for allocating tolerances
$P_6$	gap required to meet assembly quality goal
$P_{D6}$	gap required to meet assembly quality goal when using DRSS allocation
$P_{SRSS}$	expected gap when performing a static RSS analysis

$s_i$	process standard deviation for the $i$ th component in the stack
$s_{Assy}, s_{DAssy}$	standard deviation of a tolerance stack
$s_{adj}$	adjusted standard deviation used in the DRSS allocation method
$t_i, T_i$	allocated equal bilateral tolerance for the $i$ th component in the stack
$t_{jf}$	tolerance value of the $j$ th fixed (purchased parts) component in the stack
$t_{wc6}$	assembly performance criterion (parameter) for the worst case allocation method
$t_{wc}$	worst case tolerance of an assembly stack
$Z_i$	a measure of the width of the process distribution as compared to the spec limits of the $i$ th component dimension (standard normal transform)
$Z_{Assy}, Z_F$	a measure of the width of the assembly distribution as compared to the assembly requirement (standard normal transform)
$T_U, USL$	upper limit of a tolerance range
$T_L, LSL$	lower limit of a tolerance range
Cpk, Cp	capability indices

## 11.12 References

1. Bralla, James G. 1986. *Handbook of Product Design for Manufacturing*. New York, NY: McGraw-Hill Book Company.
2. Creveling, C.M. 1997. *Tolerance Design*. Reading, MA: Addison-Wesley Longman.
3. Drake, Paul and Dale Van Wyk. 1995. Classical Mechanical Tolerancing (Part I of II). *Texas Instruments Technical Journal*. Jan-Feb:39-46.
4. Glancy, Charles. 1994. A Second-Order Method for Assembly Tolerance Analysis. Master's thesis. Brigham Young University.
5. Harry, Mikel, and J.R. Lawson. 1990. *Six Sigma Producibility Analysis and Process Characterization*. Schaumburg, Illinois: Motorola University Press.
6. Harry, Mikel, and R. Stewart. 1988. *Six Sigma Mechanical Design Tolerancing*. Schaumburg, Illinois: Motorola University Press.
7. Hines, William, and Douglas Montgomery. 1990. *Probability and Statistics in Engineering and Management Sciences*. New York, NY: John Wiley and Sons.
8. Kennedy, John B., and Adam M. Neville. 1976. *Basic Statistical Methods for Engineers and Scientists*. New York, NY: Harper and Row.
9. Kiemele, Mark J. and Stephen R. Schmidt. 1991. *Basic Statistics. Tools for Continuous Improvement*. Colorado Springs, Colorado: Air Academy Press.
10. The American Society of Mechanical Engineers. 1995. *ASME Y14.5M-1994, Dimensioning and Tolerancing*. New York, NY: The American Society of Mechanical Engineers.
11. Van Wyk, Dale. 1993. Use of Tolerance Analysis to Predict Defects. *Six Sigma—Reaching Our Goal* white paper. Dallas, Texas: Texas Instruments.
12. Van Wyk, Dale and Paul Drake. 1995. Mechanical Tolerancing for Six Sigma (Part II). *Texas Instruments Technical Journal*. Jan-Feb: 47-54.