

## **Multi-Dimensional Tolerance Analysis (Manual Method)**

### **Dale Van Wyk**

**Dale Van Wyk**  
**Raytheon Systems Company**  
**McKinney, Texas**

*Mr. Van Wyk has more than 14 years of experience with mechanical tolerance analysis and mechanical design at Texas Instruments' Defense Group, which became part of Raytheon Systems Company. In addition to direct design work, he has developed courses for mechanical tolerancing and application of statistical principles to systems design. He has also participated in development of a U.S. Air Force training class, teaching techniques to use statistics in creating affordable products. He has written several papers and delivered numerous presentations about the use of statistical techniques for mechanical tolerancing. Mr. Van Wyk has a BSME from Iowa State University and a MSME from Southern Methodist University.*

### **12.1 Introduction**

The techniques for analyzing tolerance stacks that were introduced in Chapter 9 were demonstrated using a one-dimensional example. By one-dimensional, we mean that all the vectors representing the component dimensions can be laid out along a single coordinate axis. In many analyses, the contributing dimensions are not all along a single coordinate axis. One example is the Geneva mechanism shown in Fig. 12-1. The tolerances on the  $C$ ,  $R$ ,  $S$ , and  $L$  will all affect the proper function of the mechanism. Analyses like we showed in Chapters 9 and 11 are insufficient to determine the effects of each of these tolerances. In this chapter, we'll demonstrate two methods that can be used to evaluate these kinds of problems.

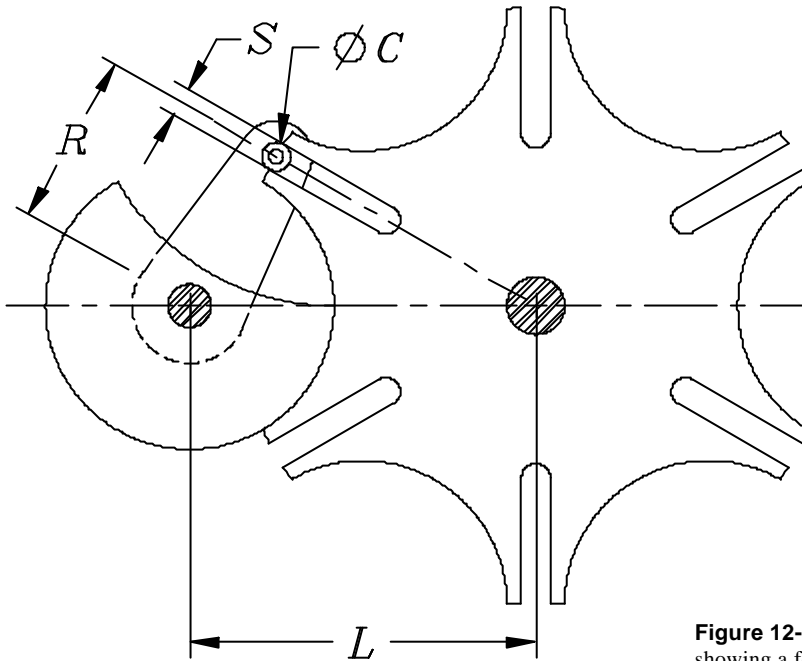

**Figure 12-1** Geneva mechanism showing a few of the relevant dimensions

The following sections describe a systematic procedure for modeling and analyzing manufacturing variation within 2-D and 3-D assemblies. The key features of this system are:

1. A critical assembly dimension is represented by a vector loop, which is analogous to the loop diagram in 1-D analysis.
2. An explicit expression is derived for the critical assembly feature in terms of the contributing component dimensions.
3. The resulting expression is used to calculate tolerance sensitivities, either by partial differentiation or numerical methods.

A key benefit is that, once the expression is derived, this method easily solves for new nominal values directly as the design changes.

## 12.2 Determining Sensitivity

Recall the equations for worst case and RSS tolerance analysis equation from Chapter 9 (Eqs. 9.2 and 9.11).

$$t_{wc} = \sum_{i=1}^n |a_i t_i| \quad (12.1)$$

$$t_{rss} = \sqrt{\sum_{i=1}^n (a_i t_i)^2} \quad (12.2)$$

The technique we'll demonstrate for multidimensional tolerance analysis uses these same equations but we'll need to develop another way to determine the value of the sensitivity,  $a_i$ , in Eqs. (12.1) and (12.2) above. We noted in Chapter 9 that sensitivity is an indicator of the effect of a dimension on the stack. In

one-dimensional stacks, the sensitivity is almost always either +1 or -1 so it is often left out of the one-dimensional tolerance equations. For the Geneva mechanism in Fig. 12-1, an increase in the distance  $L$  between the centers of rotation of the crank and the wheel require a change in the diameter,  $C$ , of the bearing, the width of the slot,  $S$ , and the length,  $R$ , of the crank. However, it won't be a one-to-one relationship like we usually have with a one-dimensional problem, so we need a different way to find sensitivity.

To see how we're going to determine sensitivity, let's start by looking at Fig. 12-2. If we know the derivative (slope) of the curve at point A, we can estimate the value of the function at points B and C as follows:

$$F(B) \approx F(A) + \Delta x \frac{dy}{dx}$$

and

$$F(C) \approx F(A) - \Delta x \frac{dy}{dx}$$

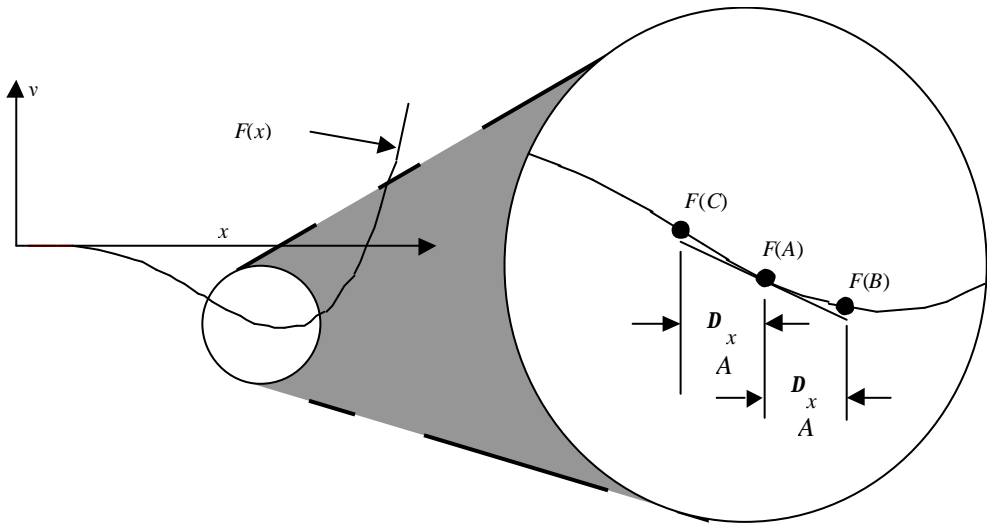

Figure 12-2 Linearized approximation to a curve

We'll use the same concept for multidimensional tolerance analysis. We can think of the tolerance as  $D_x$ , and use the sensitivity to estimate the value of the function at the tolerance extremes. As long as the tolerance is small compared to the slope of the curve, this provides a very good estimate of the effects of tolerances on the gap.

With multidimensional tolerance analysis, we usually have several variables that will affect the gap. Our function is an  $n$ -space surface instead of a curve, and the sensitivities are found by taking partial derivatives with respect to each variable. For example, if we have a function  $Q(y_1, y_2, \dots, y_n)$ , the sensitivity of  $Q$  with respect to  $y_1$  is

$$a_1 = \left. \frac{\partial Q}{\partial y_1} \right|_{\text{NominalValues}}$$

Therefore we evaluate the partial derivative at the nominal values of each of the variables. Remember that the nominal value for each variable is the center of the tolerance range, or the value of the dimension when the tolerances are equal bilateral. Once we find the values of all the sensitivities, we can use any of the tolerance analysis or allocation techniques in Chapters 9 and 11.

### 12.3 A Technique for Developing Gap Equations

Developing a gap equation is the key to performing a multidimensional tolerance analysis. We'll show one method to demonstrate the technique. While we're using this method as an example, any technique that will lead to an accurate gap equation is acceptable. Once we develop the gap equation, we'll calculate the sensitivities using differential calculus and complete the problem using any tolerance analysis or allocation technique desired. A flow chart listing the steps is shown in Fig. 12-3.

We'll solve the problem shown in Fig. 12-4. While this problem is unlikely to occur during the design process, its use demonstrates techniques that are helpful when developing gap equations.

#### Step 1. Define requirement of interest

The first thing we need to do with any tolerance analysis or allocation is to define the requirement that we are trying to satisfy. In this case, we want to be able to install the two blocks into the frame. We conducted a study of the expected assembly process, and decided that we need to have a minimum clearance of .005 in. between the top left corner of Block 2 and the Frame. We will perform a worst case analysis using the dimensions and tolerances in Table 12-1. The variable names in the table correspond to the variables shown in Fig. 12-4.

#### Step 2. Establish gap coordinate system

Our second step is establishing a coordinate system at the gap. We know that the shortest distance that will define the gap is a straight line, so we want to locate the coordinate sys-

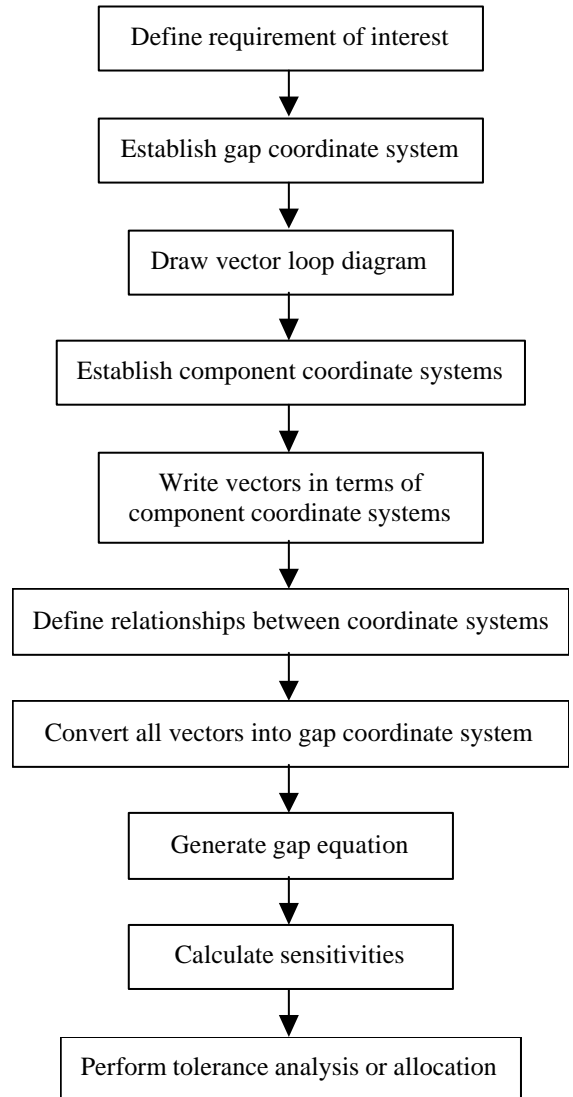

**Figure 12-3** Multidimensional tolerancing flow chart

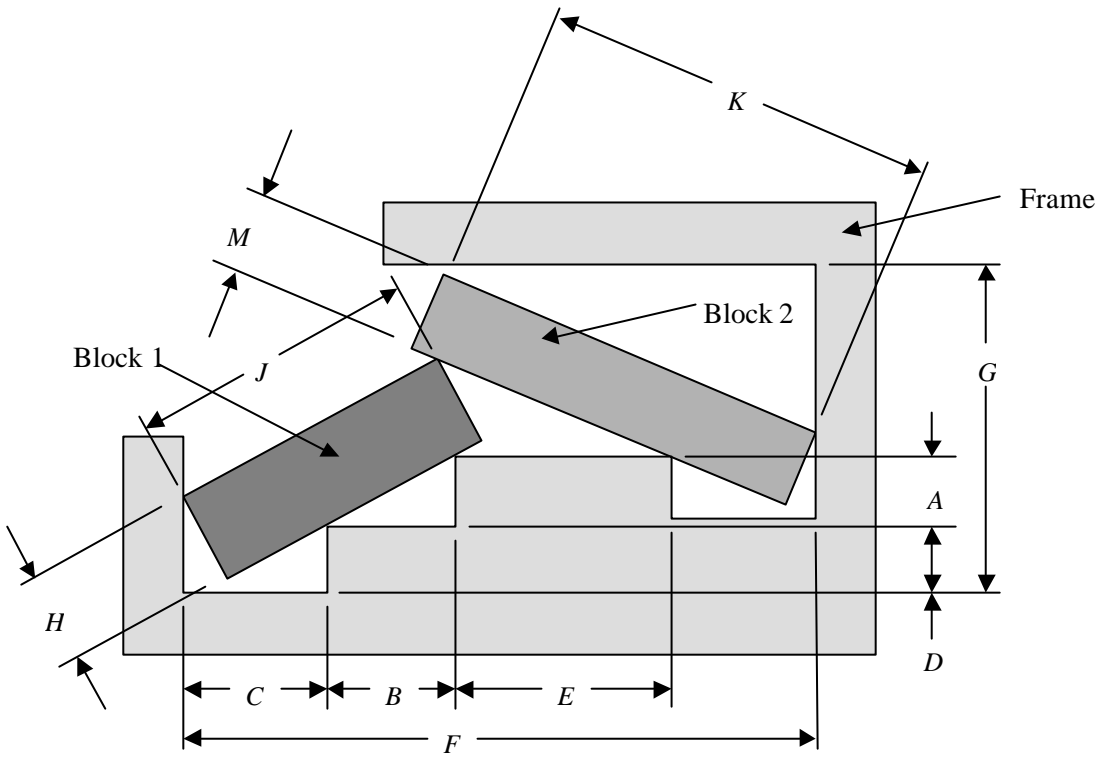

**Figure 12-4** Stacked blocks we will use for an example problem

**Table 12-1** Dimensions and tolerances corresponding to the variable names in Fig. 12-4

Variable Name	Mean Dimension (in.)	Tolerance (in.)
<i>A</i>	.875	.010
<i>B</i>	1.625	.020
<i>C</i>	1.700	.012
<i>D</i>	.875	.010
<i>E</i>	2.625	.020
<i>F</i>	7.875	.030
<i>G</i>	4.125	.010
<i>H</i>	1.125	.020
<i>J</i>	3.625	.015
<i>K</i>	5.125	.020
<i>M</i>	1.000	.010

tem along that line. We set the origin at one side of the gap and one of the axes will point to the other side, along the shortest direction. It's not important which side of the gap we choose for the origin. Coordinate system  $\{u_1, u_2\}$  is shown in Fig. 12-5 and represents a set of unit vectors.

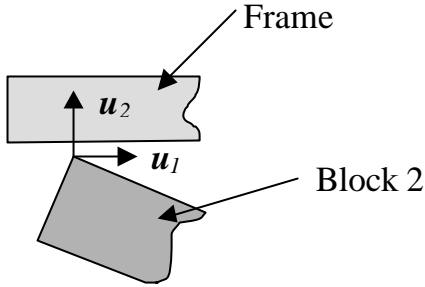

Figure 12-5 Gap coordinate system  $\{u_1, u_2\}$

**Step 3. Draw vector loop diagram**

Now we'll have to draw a vector loop diagram similar to the dimension loop diagram constructed in section 9.2.2. Just like we did with the one-dimensional loop diagram, we'll start at one side of the gap and work our way around to the other. Anytime we go from one part to another, it must be through a point or surface of contact. When we've completed our analysis, we want a positive result to represent a clearance and a negative result to represent an interference. If we start our vector loop at the origin of the gap coordinate system, we'll finish at a more positive location on the axis, and we'll achieve the desired result.

For our example problem, there are several different vector loops we can choose. Two possibilities are shown in Fig. 12-6. The solution to the problem will be the same regardless of which vector loop we choose, but some may be more difficult to analyze than others. It's generally best to choose a loop that has a minimum number of vectors that need the length calculated. In Loop T, vectors  $T_2$  and  $T_3$  need the length calculated while Loop S has five vectors with undefined lengths. We can find lengths of the vectors  $S_5$  and  $S_6$  through simple one-dimension analysis, but  $S_2, S_4,$  and  $S_6$  will require more work. So it appears that Loop T may provide easier calculations.

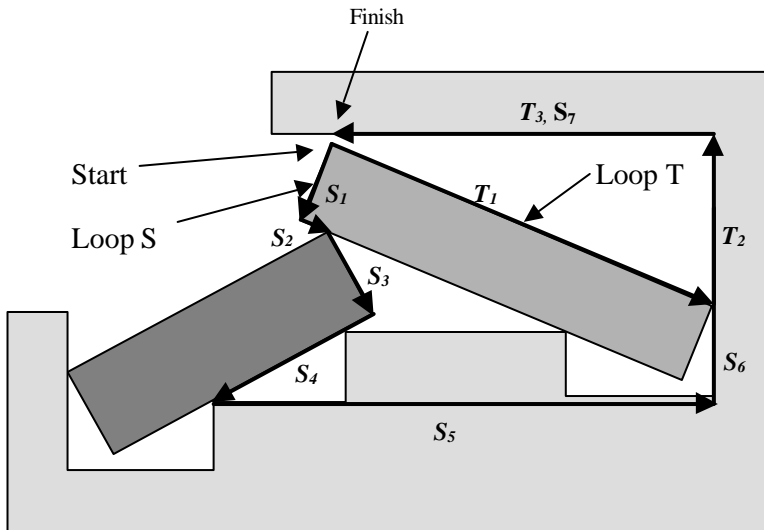
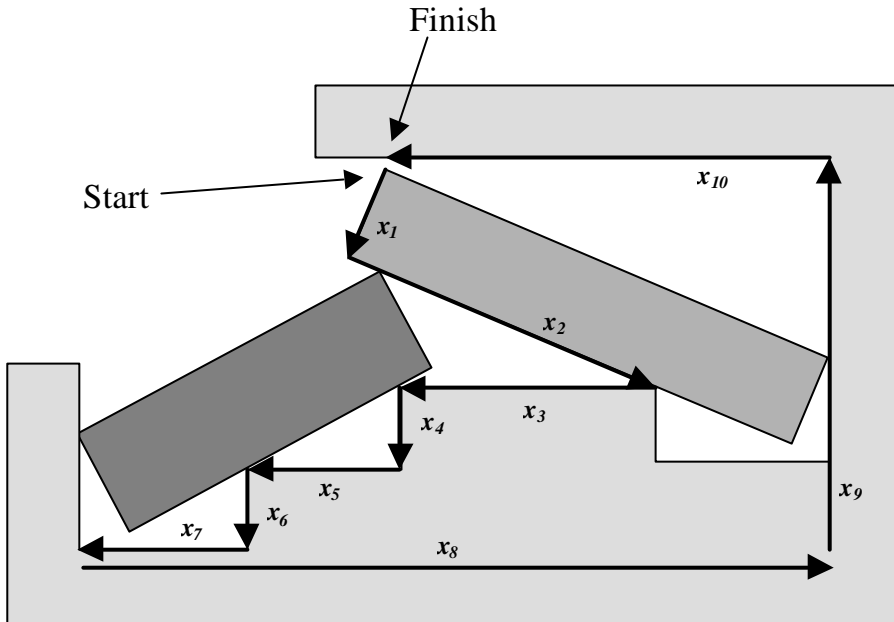

Figure 12-6 Possible vector loops to evaluate the gap of interest

As an alternative, look at the vector loop in Fig. 12-7. It has only three vectors with unknown length, one of which ( $x_9$ ) is a linear combination of other dimensions. For vectors  $x_2$  and  $x_{10}$ , we can calculate the length relatively easily. This is the loop we will use to analyze the problem.

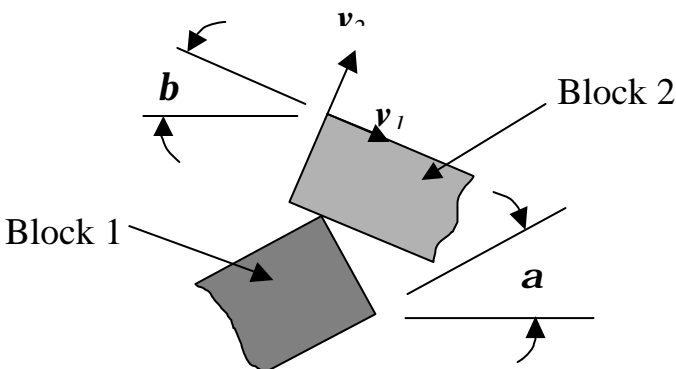

**Figure 12-7** Vector loop we will use to analyze the gap. It presents easier calculations of unknown vector lengths.

#### Step 4. Establish component coordinate systems

The next step is establishing component coordinate systems. The number needed will depend on the configuration of the assembly. The idea is to have a coordinate system that will align with every component dimension and vector that will contribute to the stack. One additional coordinate system is needed and is shown in Fig. 12-8.

Coordinate system  $\{v_1, v_2\}$  is needed for the vectors on Block 2. The dimensions on the frame align with  $\{u_1, u_2\}$  so an additional coordinate system is not needed for them. Dimensions  $J$  and  $H$  on Block 1 do not contribute directly to a vector length so they do not need a coordinate system.



**Figure 12-8** Additional coordinate system needed for the vectors on Block 2

**Step 5. Write vectors in terms of component coordinate systems**

The vectors in Fig. 12-7 are listed below in terms of their coordinate systems, angle  $\mathbf{b}$ , and the dimensional variables in Table 12-1.

$$\mathbf{x}_1 = -M\mathbf{v}_2$$

$$\mathbf{x}_2 = \left( K - \frac{F - C - B - E - M \sin \mathbf{b}}{\cos \mathbf{b}} \right) \mathbf{v}_1$$

$$\mathbf{x}_3 = -E\mathbf{u}_1$$

$$\mathbf{x}_4 = -A\mathbf{u}_2$$

$$\mathbf{x}_5 = -B\mathbf{u}_1$$

$$\mathbf{x}_6 = -D\mathbf{u}_2$$

$$\mathbf{x}_7 = -C\mathbf{u}_1$$

$$\mathbf{x}_8 = F\mathbf{u}_1$$

$$\mathbf{x}_9 = G\mathbf{u}_2$$

$$\mathbf{x}_{10} = K \cos \mathbf{b} \mathbf{u}_1$$

Angle  $\mathbf{b}$  is not known yet, so we'll have to calculate it. Angle  $\mathbf{a}$  contributes to the value of  $\mathbf{b}$ , and is also needed. The equations for angles  $\mathbf{a}$  and  $\mathbf{b}$  are shown below.

$$\begin{aligned} a &= \arctan \left( \frac{A}{B} \right) \\ &= \arctan \left( \frac{.875}{1.625} \right) \\ &= 28.30^\circ \end{aligned}$$

$$\begin{aligned} \mathbf{b} &= \arctan \left( \frac{\left( J - \frac{C - H \sin a}{\cos a} - \sqrt{A^2 + B^2} \right) \sin a + H \cos a}{E - \left( J - \frac{C - H \sin a}{\cos a} - \sqrt{A^2 + B^2} \right) \cos a + H \sin a} \right) \\ &= \arctan \left( \frac{\left( 3.625 - \frac{1.700 - 1.125 (.4741)}{.8805} - \sqrt{.875^2 + 1.625^2} \right) (.4741) + 1.125 (.8805)}{2.625 - \left( 3.625 - \frac{1.700 - 1.125 (.4741)}{.8805} - \sqrt{.875^2 + 1.625^2} \right) (.8805) + 1.125 (.4741)} \right) \\ &= 23.62^\circ \end{aligned}$$

**Step 6. Define relationships between coordinate systems**

In order to relate the vectors in Step 5 to the gap, we will have to transform them into the same coordinate system as the gap. Thus, we'll have to convert vectors  $\mathbf{x}_1$  and  $\mathbf{x}_2$  into coordinate system  $\{\mathbf{u}_1, \mathbf{u}_2\}$ . One method follows.

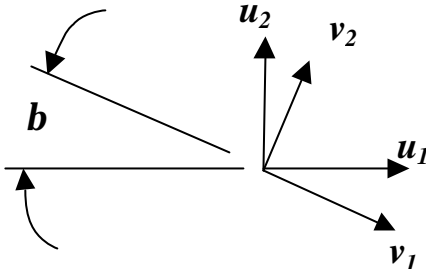

**Figure 12-9** Relationship between coordinate systems  $\{u_1, u_2\}$  and  $\{v_1, v_2\}$

$$\begin{array}{c|c|c} \begin{array}{c} v_1 \\ v_2 \end{array} & \begin{array}{c} u_1 \\ \cos b \\ \sin b \end{array} & \begin{array}{c} u_2 \\ -\sin b \\ \cos b \end{array} \end{array}$$

Fig. 12-9 shows the  $\{u_1, u_2\}$  and  $\{v_1, v_2\}$  coordinate systems and the angle  $b$  between them. To build a transformation between the two coordinate systems, we'll find the components of  $v_1$  and  $v_2$  in the directions of the unit vectors  $u_1$  and  $u_2$ . For example, the component of  $v_1$  in the  $u_1$  direction is  $\cos b$ . The component of  $v_1$  in the  $u_2$  direction is  $-\sin b$ . The sign of the sine is negative because the component is pointing in the opposite direction as the positive  $u_2$  axis. The table is completed by performing a similar analysis with vector  $v_2$ .

A matrix,  $Z$ , can be defined as follows:

$$Z = \begin{bmatrix} \cos b & -\sin b \\ \sin b & \cos b \end{bmatrix}$$

Multiplying  $Z$  by and  $\{u_1, u_2\}^T$  will give us a transformation matrix that we can use to convert any vector in the  $\{v_1, v_2\}$  coordinate system to the  $\{u_1, u_2\}$  coordinate system.

Let  $Q = Z\{u_1, u_2\}^T$

$$Q = \begin{bmatrix} \cos b & -\sin b \\ \sin b & \cos b \end{bmatrix} \begin{bmatrix} u_1 \\ u_2 \end{bmatrix}$$

$$Q = \begin{bmatrix} \cos b u_1 - \sin b u_2 \\ \sin b u_1 + \cos b u_2 \end{bmatrix}$$

Now we can transform any vector in the  $\{v_1, v_2\}$  coordinate system to the  $\{u_1, u_2\}$  coordinate system by multiplying it by  $Q$ .

Let's see how this works by transforming the vector  $2v_1 + v_2$  to the  $\{u_1, u_2\}$  coordinate system. We start by representing the vector as a matrix  $[2 \ 1]$ .

$$\begin{aligned} 2v_1 + v_2 &= [2 \ 1] \begin{bmatrix} \cos b u_1 - \sin b u_2 \\ \sin b u_1 + \cos b u_2 \end{bmatrix} \\ &= 2(\cos b u_1 - \sin b u_2) + \sin b u_1 + \cos b u_2 \\ &= (2\cos b + \sin b)u_1 + (\cos b - 2\sin b)u_2 \end{aligned}$$

### Step 7. Convert all vectors into gap coordinate system

For our problem, we need all the vectors  $x_i$  that we found in Step 5 to be represented in the  $\{u_1, u_2\}$  coordinate system. The only ones that need converting are  $x_1$  and  $x_2$ .

$$\begin{aligned} x_1 &= -Mv_2 \\ &= -M \begin{bmatrix} 0 & I \end{bmatrix} \begin{bmatrix} \cos b u_1 - \sin b u_2 \\ \sin b u_1 + \cos b u_2 \end{bmatrix} \\ &= -M(\sin b u_1 + \cos b u_2) \end{aligned}$$

Similarly,

$$\begin{aligned} x_2 &= \left( K - \frac{F - C - B - E - M \sin b}{\cos b} \right) v_1 \\ &= \left( K - \frac{F - C - B - E - M \sin b}{\cos b} \right) \begin{bmatrix} 1 & 0 \end{bmatrix} \begin{bmatrix} \cos b u_1 - \sin b u_2 \\ \sin b u_1 + \cos b u_2 \end{bmatrix} \\ &= \left( K - \frac{F - C - B - E - M \sin b}{\cos b} \right) (\cos b u_1 - \sin b u_2) \end{aligned}$$

**Step 8. Generate gap equation**

To generate the gap equation now is very easy. We only need to observe that no components in the  $u_1$  direction affect the gap. Thus, all we need to do is take the components in the  $u_2$  direction and add them together.

$$Gap = -M \cos \beta + \left( K - \frac{F - C - B - E - M \sin \beta}{\cos \beta} \right) (-\sin \beta) - A - D + G \tag{12.3}$$

Now we have to insert the nominal values of each of the dimensions along with the values of the  $\sin b$  and  $\cos b$  into Eq. (12.3).

$$\begin{aligned} Gap &= -1.000(.9162) + \left( 5.125 - \frac{7.875 - 1.700 - 1.625 - 2.625 - 1.00(.4007)}{.9162} \right) (-.4007) \\ &\quad - .875 - .875 + 4.125 \\ &= .0719 \end{aligned}$$

This is the nominal value of the gap.

**Step 9. Calculate sensitivities**

Next we need to calculate the sensitivities, which we'll find by evaluating the partial derivatives at the nominal value for each of the dimensions. As an example to the approach, we'll find the sensitivity for variable E, and provide tabulated results for the other variables.

Since  $b$  is a function of  $E$ , we'll have to apply the chain rule for partial derivatives. Let's start by redefining the gap as a function of  $b$  and  $E$ , say  $Gap = Y(b, E)$ . All the other terms will be treated as constants. Then,

$$\frac{\partial Gap}{\partial E} = \frac{\partial Y}{\partial E} \frac{dE}{dE} + \frac{\partial Y}{\partial \beta} \frac{\partial \beta}{\partial E}$$

Solving for each of the terms,

$$\begin{aligned}\frac{\partial Y}{\partial E} &= -\tan \mathbf{b} \\ &= -.4373\end{aligned}$$

$$\frac{dE}{dE} = 1$$

$$\begin{aligned}\frac{\partial Y}{\partial \mathbf{b}} &= \frac{F - C - B - E - M \sin \mathbf{b} - K (\cos \mathbf{b})^3}{(\cos \mathbf{b})^2} \\ &= \frac{7.875 - 1.700 - 1.625 - 2.625 - 1.000(.4007) - 5.125(.9162)^3}{(.9162)^2} \\ &= -2.8796\end{aligned}$$

$$\begin{aligned}\frac{\partial \mathbf{b}}{\partial E} &= \frac{-\left( J - \frac{C - H \sin \mathbf{a}}{\cos \mathbf{a}} - \sqrt{A^2 + B^2} \right) \sin \mathbf{a} - H \cos \mathbf{a}}{\left[ \left( E - \left( J - \frac{C - H \sin \mathbf{a}}{\cos \mathbf{a}} - \sqrt{A^2 + B^2} \right) \cos \mathbf{a} + H \sin \mathbf{a} \right)^2 \right.} \\ &\quad \left. + \left( \left( J - \frac{C - H \sin \mathbf{a}}{\cos \mathbf{a}} - \sqrt{A^2 + B^2} \right) \sin \mathbf{a} + H \cos \mathbf{a} \right)^2 \right]} \\ &= \frac{-\left( 3.625 - \frac{1.700 - 1.125(.4741)}{.8805} - \sqrt{.875^2 + 1.625^2} \right) (.4741) - 1.125 (.8805)}{\left[ \left( 2.625 - \left( 3.625 - \frac{1.700 - 1.125(.4741)}{.8805} - \sqrt{.875^2 + 1.625^2} \right) (.8805) + 1.125 (.4741) \right)^2 \right.} \\ &\quad \left. + \left( \left( 3.625 - \frac{1.700 - 1.125(.4741)}{.8805} - \sqrt{.875^2 + 1.625^2} \right) (.4741) + 1.125 (.8805) \right)^2 \right]} \\ &= -.1331\end{aligned}$$

$$\begin{aligned}\frac{\partial \text{Gap}}{\partial E} &= -.4373 (1) + (-2.8796) (-.1331) \\ &= -.0540\end{aligned}$$

Table 12-2 contains the sensitivities of the remaining variables. While calculating sensitivities manually is difficult for many gap equations, there are many software tools that can calculate them for us, simplifying the task considerably.

**Table 12-2** Dimensions, tolerances, and sensitivities for the stacked block assembly

Variable Name	Mean Dimension (in.)	Tolerance (in.)	Sensitivity
<i>A</i>	.875	.010	-.5146
<i>B</i>	1.625	.020	.1567
<i>C</i>	1.700	.012	.4180
<i>D</i>	.875	.010	-1.0000
<i>E</i>	2.625	.020	-.0540
<i>F</i>	7.875	.030	.4372
<i>G</i>	4.125	.010	1.0000
<i>H</i>	1.125	.020	-.9956
<i>J</i>	3.625	.015	-.7530
<i>K</i>	5.125	.020	-.4006
<i>M</i>	1.000	.010	-1.0914

**Step 10. Perform tolerance analysis or allocation**

Now that we have calculated a nominal gap (.0719 in.) and all the sensitivities, we can use any of the analysis or allocation methods in Chapters 9 and 11. In Step 1, we decided to perform a worst case analysis. Using Eq. (12.1),

$$\begin{aligned}
 t_{wc} &= |(-.5146)(.010)| + |(.1567)(.020)| + |(.4180)(.012)| + |(-1)(.010)| + \\
 &|(-.0540)(.020)| + |(.4372)(.030)| + |(1)(.010)| + |(-.9956)(.020)| + \\
 &|(-.7530)(.015)| + |(-.4006)(.020)| + |(1)(.010)| \\
 &= .0967
 \end{aligned}$$

The minimum gap expected at worst case will be .0719 - .0967 = -.0248 in.

The negative number indicates that we can have an interference at worst case, and we do not satisfy our assembly requirement of a minimum clearance of .005 in.

**12.4 Utilizing Sensitivity Information to Optimize Tolerances**

Since we don't meet our assembly requirement, we need to consider some alterations to the design. We can use the sensitivities to help us make decisions about what we should target for change. For example, dimensions B and E have small sensitivities, so changing the tolerance on them will have little effect on the gap. To reduce the magnitude of the worst case tolerance stack, we would target the dimensions with the largest sensitivity first.

Also, the sensitivities help us decide which dimension we should consider changing to increase the gap. It takes a large change in a dimension with a small sensitivity to make a significant change in the gap. For example, making Dimension *E* .018 in. smaller will make the gap only about .001 in. larger. Conversely, making Dimension *M* .001 in. smaller will make the gap slightly more than .001 in. larger. If our goal is to correct the problem of assembly fit without changing the design any more than necessary, working with the dimensions with the largest sensitivities will be advantageous.

The simplest solution would be to increase the opening in the frame, Dimension *G*, from 4.125 in. to 4.160 in. which will provide the clearance we need. However, if we assume the thickness of the top of the frame can't change, that will cause us to increase the size of the frame. That could be a problem. So instead, we'll change one of the internal dimensions on the frame, making Dimension *A* equal to .815 in. With this

change, the nominal gap will be .1044 in., worst case tolerance stack is .0980 in. and the minimum clearance is .0064 in.

The worst case tolerance stack increased because many of the sensitivities changed when *A* was changed. This is because we evaluate the partial derivatives at the nominal value of the dimensions, so when the nominal value of *A* was changed, we changed the calculated result. Another way to think of it is that we moved to a different point in our design space when we changed Dimension *A*, so the slope changed in several different directions.

The final dimensions, tolerances and sensitivities are shown in Table 12-3.

**Table 12-3** Final dimensions, tolerances and sensitivities of the stacked block assembly

Variable Name	Mean Dimension (in.)	Tolerance (in.)	Sensitivity
<i>A</i>	.815	.010	-.5605
<i>B</i>	1.625	.020	.1642
<i>C</i>	1.700	.012	.3846
<i>D</i>	.875	.010	-1.0000
<i>E</i>	2.625	.020	-.0552
<i>F</i>	7.875	.030	.4488
<i>G</i>	4.125	.010	1.0000
<i>H</i>	1.125	.020	-.9811
<i>J</i>	3.625	.015	-.7450
<i>K</i>	5.125	.020	-.4094
<i>M</i>	1.000	.010	-1.0961

## 12.5 Summary

In this section, we've demonstrated a technique for analyzing tolerances for multi-dimensional problems. While this is an approximate method, the results are very good as long as tolerances are not too large compared to the curvature of the *n*-space surface represented by the gap equation. It's good to remember that once we have found the gap equation and calculated the sensitivities, we can use any of the analysis or allocation techniques discussed in Chapters 9 and 11.

An important point to reiterate is that we show one method for developing a gap equation. While this will give accurate results, it may be more cumbersome at times than deriving the equation directly from the geometry of the problem. In general, the more complicated problems will be easier to solve using the technique shown here because it helps break the problem into smaller pieces that are more convenient to evaluate.

In this section, we evaluated an assembly that is not similar to ones found during the design process, but the technique works equally well on typical design problems. In fact, one thing very powerful about this technique is that it is not limited to traditional tolerance stacks. For example, we can use it to evaluate the effect of tolerances on the magnitude of the maximum stress in a loaded, cantilevered beam. Once we have developed the stress equation, we can calculate the sensitivities and determine the effect of things like the length, width and thickness of the beam, location of the load, and material properties such as the modulus of elasticity and yield strength. It even works well for electrical problems, such as evaluating the range of current we'll see in a circuit due to tolerances on the electrical components.