

Multi-Dimensional Tolerance Analysis (Automated Method)

Kenneth W. Chase, Ph.D.
Brigham Young University
Provo, Utah

Dr. Chase has taught mechanical engineering at the Brigham Young University since 1968. An advocate of computer technology, he has served as a consultant to industry on numerous projects involving engineering software applications. He served as a reviewer of the Motorola Six Sigma Program at its inception. He also served on an NSF select panel for evaluating tolerance analysis research needs. In 1984, he founded the ADCATS consortium for the development of CAD-based tools for tolerance analysis of mechanical assemblies. More than 30 sponsored graduate theses have been devoted to the development of the tolerance technology contained in the CATS software. Several faculty and students are currently involved in a broad spectrum of research projects and industry case studies on statistical variation analysis. Past and current sponsors include Allied Signal, Boeing, Cummins, FMC, Ford, GE, HP, Hughes, IBM, Motorola, Sandia Labs, Texas Instruments, and the US Navy.

13.1 Introduction

In this chapter, an alternative method to the one described in Chapter 12 is presented. This method is based on vector loop assembly models, but with the following distinct differences:

1. A set of rules is provided to assure a valid set of vector loops is obtained. The loops include only those controlled dimensions that contribute to assembly variation. All dimensions are datum referenced.
2. A set of kinematic modeling elements is introduced to assist in identifying the adjustable dimensions within the assembly that change to accommodate dimensional variations.

13-2 Chapter Thirteen

3. In addition to describing variation in assembly gaps, a comprehensive set of assembly tolerance requirements is introduced, which are useful to designers as performance requirements.
4. Algebraic manipulation to derive an explicit expression for the assembly feature is eliminated. This method operates equally well on implicit assembly equations. The loop equations are solved the same way every time, so it is well suited for computer automation.

This chapter distinguishes itself from Chapter 12 by replacing differentiation of a complicated assembly expression with a single matrix operation, which determines all necessary tolerance sensitivities simultaneously. Since the matrix only contains sines and cosines, derivations are simple. As with the method shown in Chapter 12, this method may also include other sources of variation, such as position tolerance, parallelism error, or profile variations.

13.2 Three Sources of Variation in Assemblies

There are three main sources of variation, which must be accounted for in mechanical assemblies:

1. Dimensional variations (lengths and angles)
2. Geometric form and feature variations (position, roundness, angularity, etc.)
3. Kinematic variations (small adjustments between mating parts)

Dimensional and form variations are the result of variations in the manufacturing processes or raw materials used in production. Kinematic variations occur at assembly time, whenever small adjustments between mating parts are required to accommodate dimensional or form variations.

The two-component assembly shown in Figs. 13-1 and 13-2 demonstrates the relationship between dimensional and form variations in an assembly and the small kinematic adjustments that occur at assembly time. The parts are assembled by inserting the cylinder into the groove until it makes contact on the two sides of the groove. For each set of parts, the distance U will adjust to accommodate the current value of dimensions A , R , and q . The assembly resultant U represents the nominal position of the cylinder, while $U + DU$ represents the position of the cylinder when the variations DA , DR , and Dq are present. This adjustability of the assembly describes a kinematic constraint, or a closure constraint on the assembly.

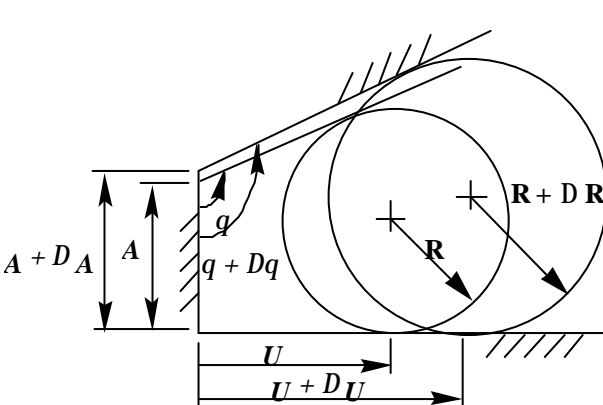

Figure 13-1 Kinematic adjustment due to component dimension variations

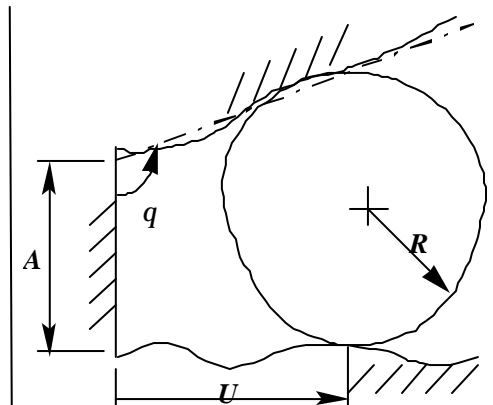

Figure 13-2 Adjustment due to geometric shape variations

It is important to distinguish between component and assembly dimensions in Fig. 13-1. Whereas A , R , and q are component dimensions, subject to random process variations, distance U is not a component dimension. It is a resultant assembly dimension. U is not a manufacturing process variable, it is a kinematic assembly variable. Variations in U can only be measured after the parts are assembled. A , R , and q are the independent random sources of variation in this assembly. They are the inputs. U is a dependent assembly variable. It is the output.

Fig. 13-2 illustrates the same assembly with exaggerated geometric feature variations. For production parts, the contact surfaces are not really flat and the cylinder is not perfectly round. The pattern of surface waviness will differ from one part to the next. In this assembly, the cylinder makes contact on a peak of the lower contact surface, while the next assembly may make contact in a valley. Similarly, the lower surface is in contact with a lobe of the cylinder, while the next assembly may make contact between lobes.

Local surface variations such as these can propagate through an assembly and accumulate just as size variations do. Thus, in a complete assembly model all three sources of variation must be accounted for to assure realistic and accurate results.

13.3 Example 2-D Assembly – Stacked Blocks

The assembly in Fig. 13-3 illustrates the tolerance modeling process. It consists of three parts: a Block, resting on a Frame, is used to position a Cylinder, as shown. There are four different mating surface conditions that must be modeled. The gap G , between the top of the Cylinder and the Frame, is the critical assembly feature we wish to control. Dimensions a through f , r , R , and q are dimensions of component features that contribute to assembly variation. Tolerances are estimates of the manufacturing process variations. Dimension g is a utility dimension used in locating gap G .

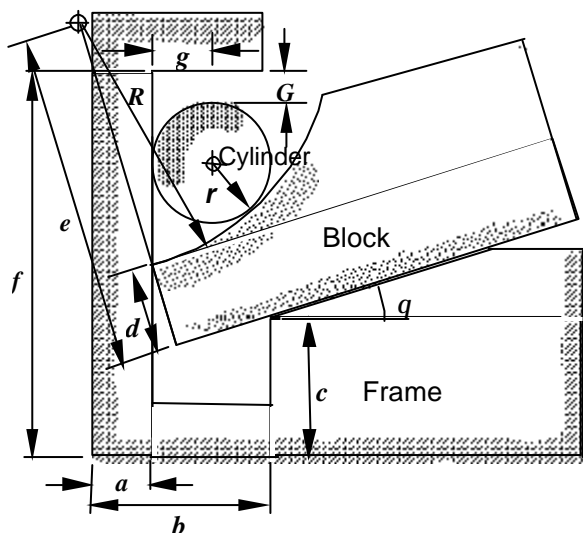

Dim	Nominal	Tolerance
a	10.00 mm	± 0.3 mm
b	30.00	± 0.3
c	31.90	± 0.3
d	15.00	± 0.3
e	55.00	± 0.3
f	75.00	± 0.5
g	10.00	± 0
r	10.00	± 0.1
R	40.00	± 0.3
q	17.0 deg	± 1.0 deg

Figure 13-3 Stacked blocks assembly

13.4 Steps in Creating an Assembly Tolerance Model

Step 1. Create an assembly graph

An assembly graph is a simplified diagram representing an assembly. All geometry and dimensions are removed. Only the mating conditions between the parts are shown. Each part is shown as a balloon. The

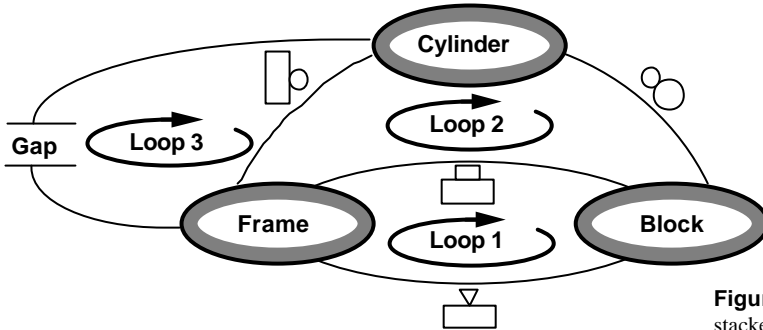

Figure 13-4 Assembly graph of the stacked blocks assembly

contacts or joints between mating parts are shown as arcs or edges joining the corresponding parts. Fig. 13-4 shows the assembly graph for the sample problem.

The assembly graph lets you see the relationship between the parts in the assembly. It also reveals by inspection how many loops (dimension chains) will be required to build the tolerance model. Loops 1 and 2 are closed loop assembly constraints, which locate the Block and Cylinder relative to the Frame. Loop 3 is an open loop describing the assembly performance requirement. A systematic procedure for defining the loops is illustrated in the steps that follow.

Symbols have been added to each edge identifying the type of contact between the mating surfaces. Between the Block and Frame there are two contacts: plane-to-plane and edge-to-plane. These are called Planar and Edge Slider joints, respectively, after their kinematic counterparts.

Only six kinematic joint types are required to describe the mating part contacts occurring in most 2-D assemblies, as shown in Fig. 13-5. Arrows indicate the degrees of freedom for each joint, which permit relative motion between the mating surfaces. Also shown are two datum systems described in the next section.

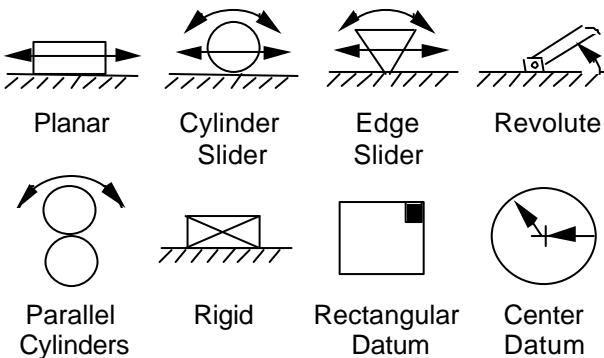

Figure 13-5 2-D kinematic joint and datum types

Step 2. Locate the datum reference frame for each part

Creating the tolerance model begins with an assembly drawing, preferably drawn to scale. Elements of the tolerance model are added to the assembly drawing as an overlay. The first elements added are a set of local coordinate systems, called *Datum Reference Frames*, or DRFs. Each part must have its own DRF. The DRF is used to locate features on a part. You probably will choose the datum planes used to define the parts. But, feel free to experiment. As you perform the tolerance analysis, you may find a different dimensioning scheme that reduces the number of variation sources or is less sensitive to variation. Identifying such effects and recommending appropriate design changes is one of the goals of tolerance analysis.

In Fig. 13-6, the Frame and Block both have rectangular DRFs located at their lower left corners, with axes oriented along orthogonal surfaces. The Cylinder has a cylindrical DRF system at its center. A second center datum has been used to locate the center of the large arc on the Block. This is called a *feature datum* and it is used to locate a single feature on a part. It represents a virtual point on the Block and must be located relative to the Block DRF.

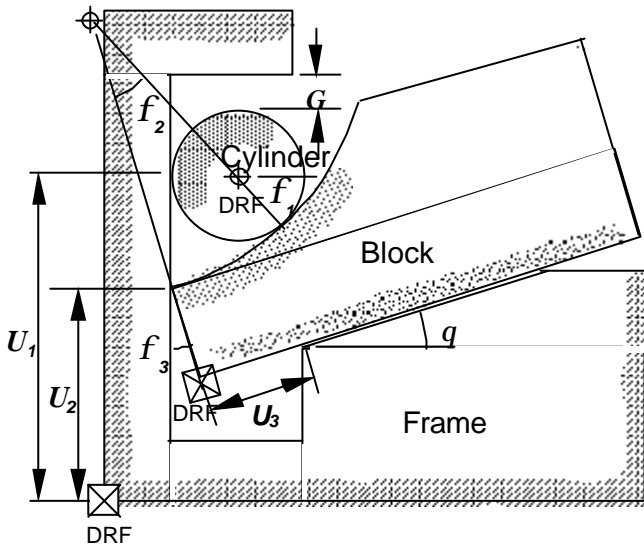

Figure 13-6 Part datums and assembly variables

Also shown in Fig. 13-6 are the assembly variables occurring within this assembly. U_1 , U_2 , and U_3 are adjustable dimensions determined by the sliding contacts between the parts. f_1 , f_2 , and f_3 define the adjustable rotations that occur in response to dimensional variations. Each of the adjustable dimensions is associated with a kinematic joint. Dimension G is the gap whose variation must be controlled by setting appropriate tolerances on the component dimensions.

Step 3. Locate kinematic joints and create datum paths

In Fig. 13-7, the four kinematic joints in the assembly are located at points of contact and oriented such that the joint axes align with the adjustable assembly dimensions (called the *joint degrees of freedom*). This is done by inspection of the contact surfaces. There are simple modeling rules for each joint type. Joint 1 is an edge slider. It represents an edge contacting a planar surface. It has two degrees of freedom: it can slide along the contact plane (U_2) and rotate relative to the contact point (f_3). Of course, it is constrained not to slide or rotate by contact with mating parts, but a change in dimensions a , b , c , d , or q will cause U_2 and f_3 to adjust accordingly.

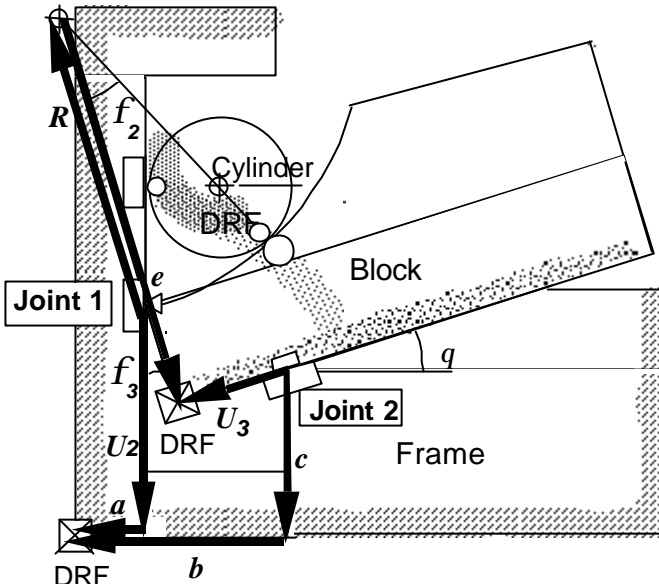

Figure 13-7 Datum paths for Joints 1 and 2

Joint 2 is a planar joint describing sliding contact between two planes. U_3 locates a reference point on the contacting surface relative to the Block DRF. U_3 is constrained by the corner of the Block resting against the vertical wall of the Frame.

In Fig. 13-8, Joint 3 locates the contact point between the Cylinder and the Frame. A cylinder slider has two degrees of freedom: U_1 is in the sliding plane and f_1 is measured at the center datum of the Cylinder. Joint 4 represents contact between two parallel cylinders. The point of contact on the Cylinder is located by f_1 ; on the Block, by f_2 . Joints 3 and 4 are similarly constrained. However, changes in component dimensions cause adjustments in the points of contact from one assembly to the next.

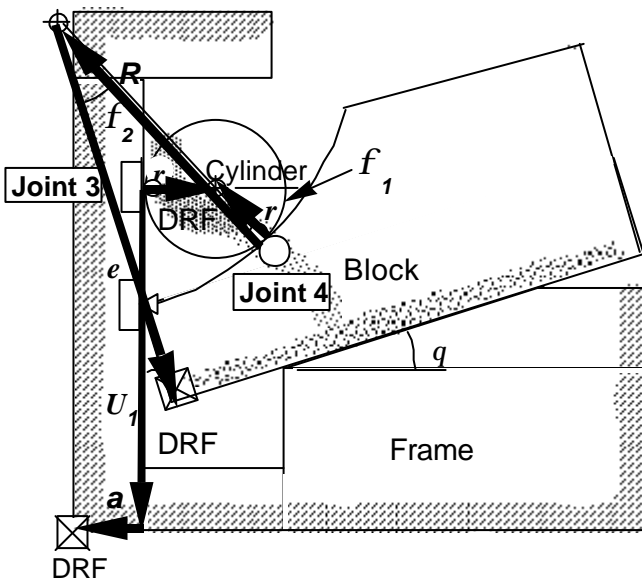

Figure 13-8 Datum paths for Joints 3 and 4

The vectors overlaid on Figs. 13-7 and 13-8 are called the *datum paths*. A datum path is a chain of dimensions that locates the point of contact at a joint with respect to a part DRF. For example, Joint 2 in Fig. 13-7 joins the Block to the Frame. The point of contact must be defined from both the Frame and Block DRFs. There are two vector paths that leave Joint 2. U_3 lies on the sliding plane and points to the Block DRF. Vectors c and b point to the Frame DRF. The two datum paths for Joint 1 are: vectors U_2 and a leading to the Frame DRF, and arc radius R and vector e , leading to the Block DRF. In Fig. 13-8, Joint 3 is located by radius r pointing to the Cylinder DRF, and U_1 and a defining the path to the Frame DRF. The contact point for Joint 4 is located by a second radius r pointing to the Cylinder DRF and arc radius R and e leading to the Block DRF.

Modeling rules define the path a vector loop must follow to cross a joint. Fig. 13-9 shows the correct vector paths for crossing four 2-D joints. The rule states that the loop must enter and exit a joint through the local joint datums. For the Planar and Edge Slider joints, a vector U (either incoming or outgoing) must lie in the sliding plane. Local Datum 2 represents a reference point on the sliding plane, from which the contact point is located. For the Cylindrical Slider joint, the incoming vector passes through center datum of the cylinder, follows a radius vector to the contact point and leaves through a vector in the sliding plane. The path through the parallel cylinder joint passes from the center datum of one cylinder to the center datum of the other, passing through the contact point and two colinear radii in between.

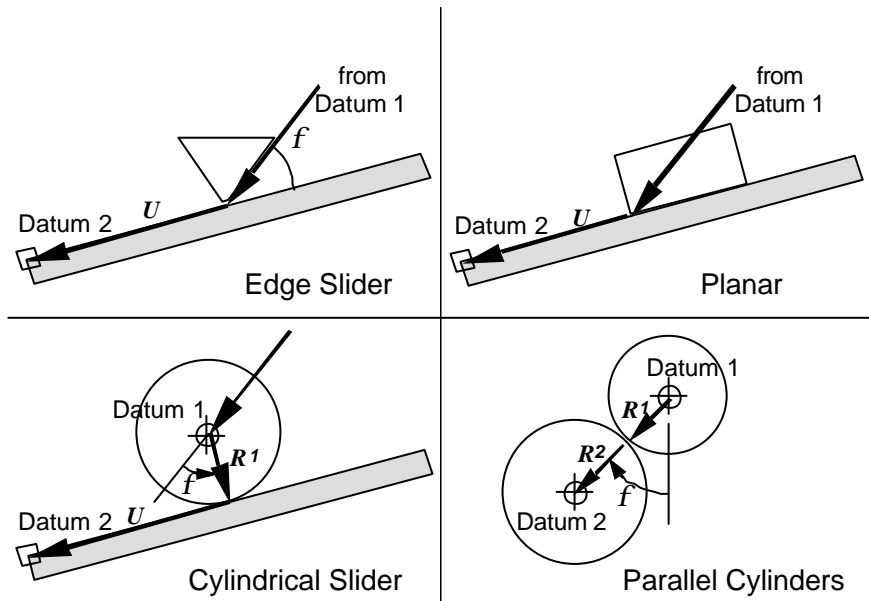

Figure 13-9 2-D vector path through the joint contact point

As we created the two datum paths from each joint, we were in fact creating the incoming and outgoing vectors for each joint. Although they were both drawn as outgoing vector paths, when we combine them to form the vector loops, one of the datum paths will be reversed in direction to correspond to the vector loop direction.

Each joint introduces kinematic variables into the assembly, which must be included in the vector model. The rules assure that the kinematic variables introduced by each joint are included in the loop, namely, the vector U in each sliding plane, and the relative angle f .

13-8 Chapter Thirteen

Each datum path must follow controlled engineering dimensions or adjustable assembly dimensions. This is a critical task, as it determines which dimensions will be included in the tolerance analysis. All joint degrees of freedom must also be included in the datum paths. They are the unknown variations in the assembly tolerance analysis.

Step 4. Create vector loops

Vector loops define the assembly constraints that locate the parts of the assembly relative to each other. The vectors represent the dimensions that contribute to tolerance stackup in the assembly. The vectors are joined tip-to-tail, forming a chain, passing through each part in the assembly in succession.

A vector loop must obey certain modeling rules as it passes through a part. It must:

- Enter through a joint
- Follow the datum path to the DRF
- Follow a second datum path leading to another joint, and
- Exit to the next adjacent part in the assembly

This is illustrated schematically in Fig. 13-10. Thus, vector loops are created by simply linking together the datum paths. By so doing, all the dimensions will be datum referenced.

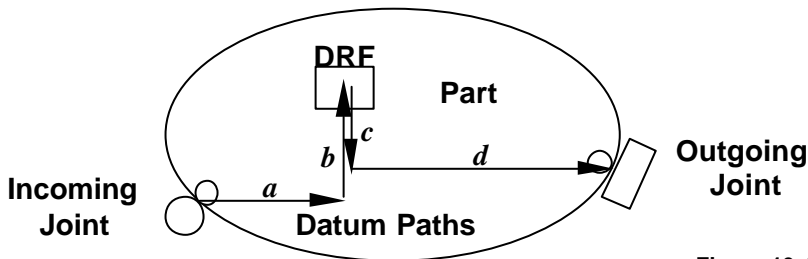

Figure 13-10 2-D vector path across a part

Additional modeling rules for vector loops include:

- Loops must pass through every part and every joint in the assembly.
- A single vector loop may not pass through the same part or the same joint twice, but it may start and end in the same part.
- If a vector loop includes the exact same dimension twice, in opposite directions, the dimension is redundant and must be omitted.
- There must be enough loops to solve for all of the kinematic variables (joint degrees of freedom). You will need one loop for each of the three variables.

Two closed loops are required for the example assembly, as we saw in the assembly graph of Fig. 13-4. The resulting loops are shown in Figs. 13-11 and 13-12. Notice how similar the loops are to the datum paths of Figs. 13-7 and 13-8. Also, notice that some of the vectors in the datum paths were reversed to keep all the vectors in each loop going in the same direction.

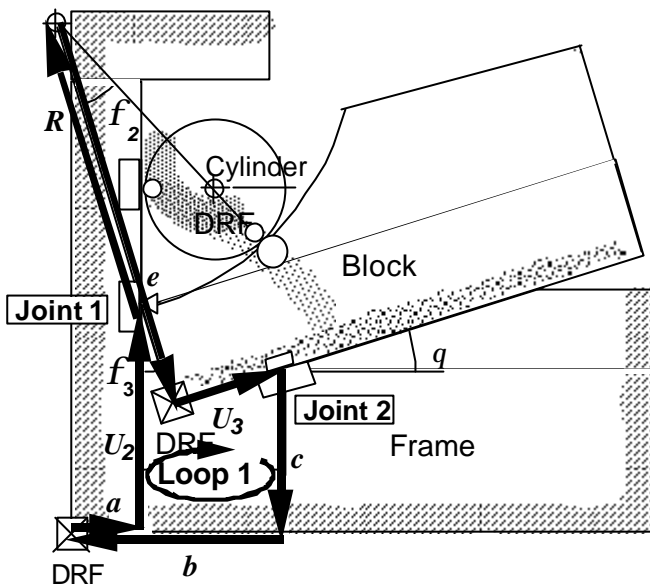

Figure 13-11 Assembly Loop 1

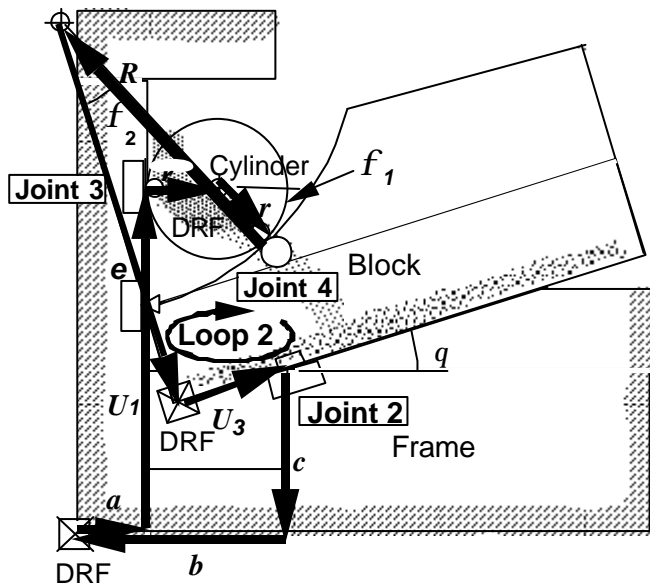

Figure 13-12 Assembly Loop 2

Step 5. Add geometric variations

Geometric variations of form, orientation, and location can introduce variation into an assembly. Such variations can accumulate statistically and propagate kinematically the same as size variations. The manner in which geometric variation propagates across mating surfaces depends on the nature of the contact. Fig. 13-13 illustrates this concept.

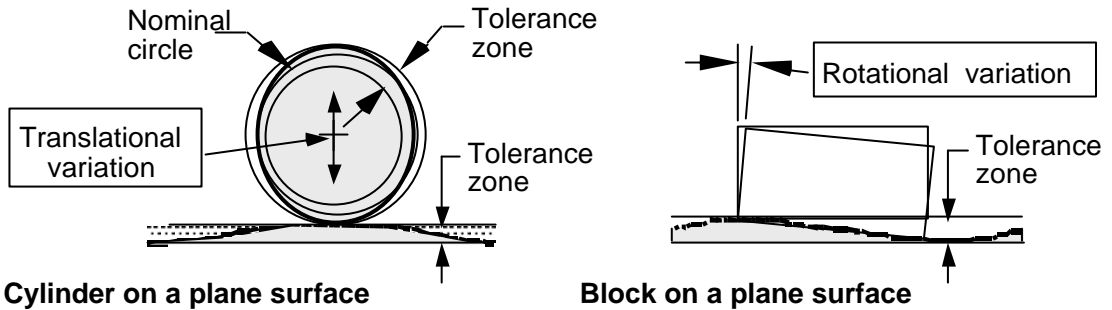

Figure 13-13 Propagation of 2-D translational and rotational variation due to surface waviness

Consider a cylinder on a plane, both of which are subject to surface waviness, represented by a tolerance zone. As the two parts are brought together to be assembled, the cylinder could rest on the top of a hill or down in a valley of a surface wave. Thus, for this case, the center of the cylinder will exhibit translational variation from assembly-to-assembly in a direction normal to the surface. Similarly, the cylinder could be lobed, as shown in the figure, resulting in an additional vertical translation, depending on whether the part rests on a lobe or in between.

In contrast to the cylinder/plane joint, the block on a plane shown in Fig. 13-13 exhibits rotational variation. In the extreme case, one corner of the block could rest on a waviness peak, while the opposite corner could be at the bottom of the valley. The magnitude of rotation would vary from assembly-to-assembly. Waviness on the surface of the block would have a similar effect.

In general, for two mating surfaces, we would have two independent surface variations that introduce variation into the assembly. How it propagates depends on the nature of the contact, that is, the type of kinematic joint. While there is little or no published data on typical surface variations for manufacturing processes, it is still instructive to insert estimates of variations and calculate the magnitude of their possible contribution. Fig. 13-14 illustrates several estimated geometric variations added to the sample assembly model. Only one variation is defined at each joint, since both mating surfaces have the same sensitivity. Examining the percent contribution to the gap variation will enable us to determine which surfaces should have a GD&T tolerance control.

Step 6. Define performance requirements

Performance requirements are engineering design requirements. They apply to assemblies of parts. In tolerance analysis, they are the specified limits of variation of the assembly features that are critical to product performance, sometimes called the *key characteristics* or *critical feature tolerances*. Several examples were illustrated in Chapter 9 for an electric motor assembly. Simple fits between a bearing and shaft, or a bearing and housing, would only involve two parts, while the radial and axial clearance between the armature and housing would involve a tolerance stackup of several parts and dimensions.

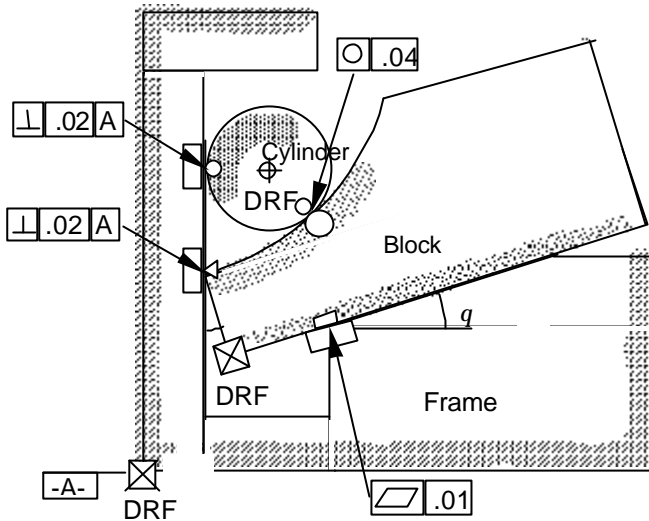

Figure 13-14 Applied geometric variations at contact points

Component tolerances are set as a result of analyzing tolerance stackup in an assembly and determining how each component dimension contributes to assembly variation. Processes and tooling are selected to meet the required component tolerances. Inspection and gaging equipment and procedures are also determined by the resulting component tolerances. Thus, we see that the performance requirements have a pervasive influence on the entire manufacturing enterprise. It is the designer's task to transform each performance requirement into assembly tolerances and corresponding component tolerances.

There are several assembly features that commonly arise in product design. A fairly comprehensive set can be developed by examining geometric dimensioning and tolerancing feature controls and forming a corresponding set for assemblies. Fig. 13-15 shows a basic set that can apply to a wide range of assemblies.

Note that when applied to an assembly feature, parallelism applies to two surfaces on two different parts, while GD&T standards only control parallelism between two surfaces on the same part. The same can be said about the other assembly controls, with the exception of position. Position tolerance in GD&T relates assemblies of two parts, while the position tolerance in Fig. 13-15 could involve a whole chain of intermediate parts contributing variation to the position of mating features on the two end parts. An example of the application of assembly tolerance controls is the alignment requirements in a car door assembly. The gap between the edge of the door and the door frame must be uniform and flush (parallel in two planes). The door striker must line up with the door lock mechanism (position).

Each assembly feature, such as a gap or parallelism, requires an open loop to describe the variation. You can have any number of open loops in an assembly tolerance model, one per critical feature. Closed loops, on the other hand, are limited to the number of loops required to locate all of the parts in the assembly. It is a unique number determined by the number of parts and joints in the assembly.

$$L = J - P + 1$$

where L is the required number of loops, J is the number of joints, and P is the number of parts. For the example problem:

$$L = 4 - 3 + 1 = 2$$

which is the number we determined by inspection of the assembly graph.

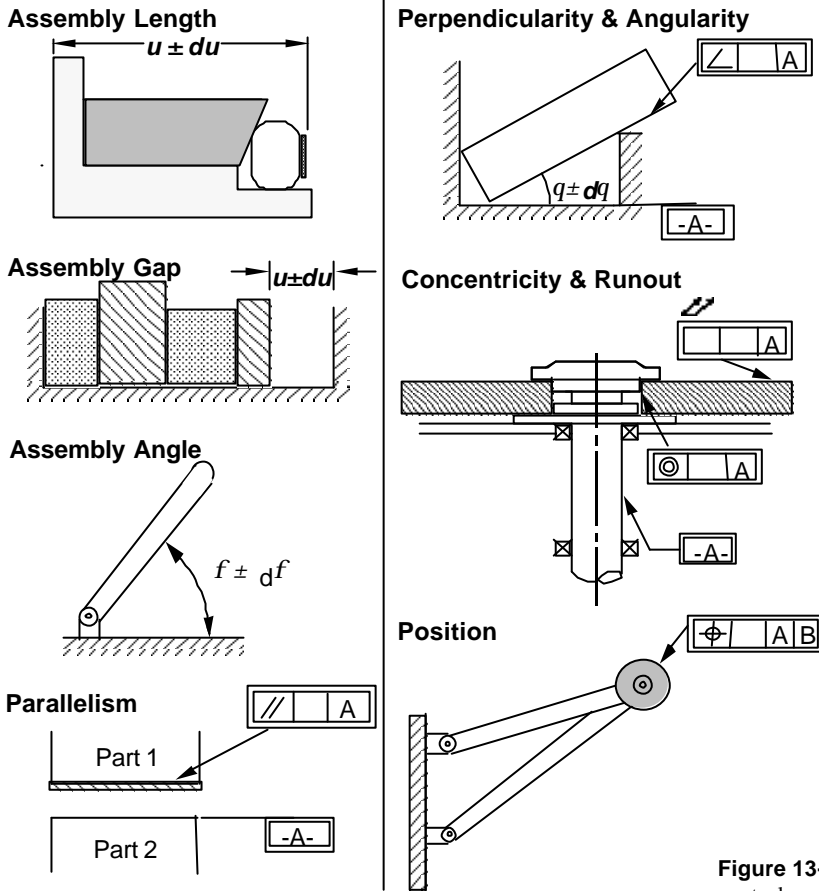

Figure 13-15 Assembly tolerance controls

The example assembly has a specified gap tolerance between a cylindrical surface and a plane, as shown in Fig. 13-6. The vector loop describing the gap is shown in Fig. 13-16. It begins with vector g , on one side of the gap, proceeds from part-to-part, and ends at the top of the cylinder, on the opposite side of the gap. Note that vector a , at the DRF of the Frame, appears twice in the same loop in opposite directions. It is therefore redundant and both vectors must be eliminated. Vector r also appears twice in the cylinder; however, the two vectors are not in opposite directions, so they must both be included in the loop.

Vector g , incidentally, is not a manufactured dimension. It is really a kinematic variable, which adjusts to locate the point on the gap opposite the highest point on the cylinder. It was given zero tolerance, because it does not contribute to the variation of the gap.

The steps illustrated above describe a comprehensive system for creating assembly models for tolerance analysis. With just a few basic elements, a wide variety of assemblies may be represented. Next, we will illustrate the steps in performing a variational analysis of an assembly model.

13.5 Steps in Analyzing an Assembly Tolerance Model

In a 2-D or 3-D assembly, component dimensions can contribute to assembly variation in more than one direction. The magnitude of the component contributions to the variation in a critical assembly feature is determined by the product of the process variation and the tolerance sensitivity, summed by worst case

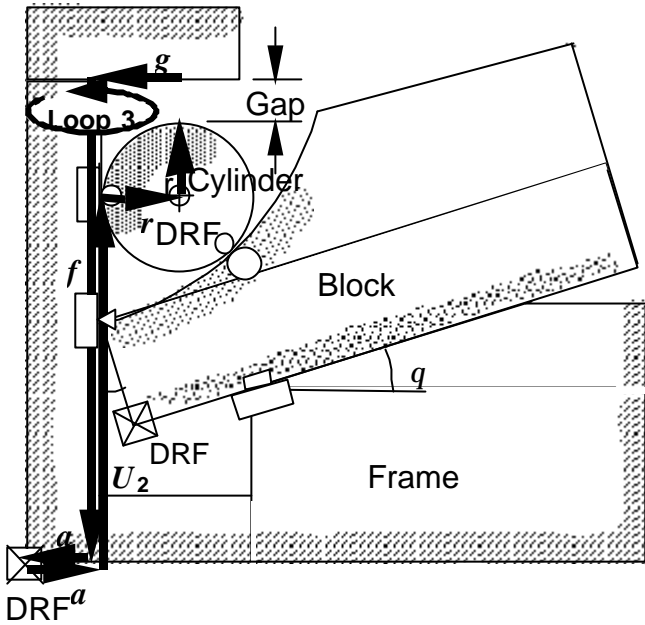

Figure 13-16 Open loop describing critical assembly gap

or Root Sum Squared (RSS). If the assembly is in production, actual process capability data may be used to predict assembly variation. If production has not yet begun, the process variation is approximated by substituting the specified tolerances for the dimensions, as described earlier.

The tolerance sensitivities may be obtained numerically from an explicit assembly function, as illustrated in Chapter 12. An alternative procedure will be demonstrated, which does not require the derivation of an explicit assembly function. It is a systematic method, which may be applied to any vector loop assembly model.

Step 1. Generate assembly equations from vector loops

The first step in an analysis is to generate the assembly equations from the vector loops. Three scalar equations describe each closed vector loop. They are derived by summing the vector components in the x and y directions, and summing the vector rotations as you trace the loop. For closed loops, the components sum to zero. For open, they sum to a nonzero gap or angle.

The equations describing the stacked block assembly are shown below. For Closed Loops 1 and 2, h_x , h_y , and h_q are the sums of the x , y , and rotation components, respectively. See Eqs. (13.1) and (13.2). Both loops start at the lower left corner, with vector a . For Open Loop 3, only one scalar equation (Eq. (13.6)) is needed, since the gap has only a vertical component. Open loops start at one side of the gap and end at the opposite side.

Closed Loop 1

$$h_x = a \cos(0) + U_2 \cos(90) + R \cos(90 + \mathbf{f}_3) + e \cos(90 + \mathbf{f}_3 - 180) + U_3 \cos(\mathbf{q}) \\ + c \cos(-90) + b \cos(-180) = 0$$

$$h_y = a \sin(0) + U_2 \sin(90) + R \sin(90 + \mathbf{f}_3) + e \sin(90 + \mathbf{f}_3 - 180) + U_3 \sin(\mathbf{q}) \\ + c \sin(-90) + b \sin(-180) = 0 \quad (13.1)$$

Closed Loop 2

$$\begin{aligned}
 h_x &= a \cos(0) + U_1 \cos(90) + r \cos(0) + r \cos(-f_1) + R \cos(-f_1 + 180) + e \cos(-f_1 - f_2) \\
 &\quad + U_3 \cos(q) + c \cos(-90) + b \cos(-180) = 0 \\
 h_y &= a \sin(0) + U_1 \sin(90) + r \sin(0) + r \sin(-f_1) + R \sin(-f_1 + 180) + e \sin(-f_1 - f_2) \\
 &\quad + U_3 \sin(q) + c \sin(-90) + b \sin(-180) = 0 \\
 h_q &= 0 + 90 - 90 - f_1 + 180 - f_2 - 180 + 90 - q - 90 - 90 + 180 = 0
 \end{aligned}
 \tag{13.2}$$

Open Loop 3

$$\text{Gap} = r \sin(-90) + r \sin(180) + U_1 \sin(-90) + f \sin(90) + g \sin(0)
 \tag{13.3}$$

The loop equations relate the assembly variables: $U_1, U_2, U_3, f_1, f_2, f_3$, and Gap to the component dimensions: a, b, c, e, f, g, r, R , and q . We are concerned with the effect of small changes in the component variables on the variation in the assembly variables.

Note the uniformity of the equations. All h_x components are in terms of the cosine of the angle the vector makes with the x -axis. All h_y are in terms of the sine. In fact, just replace the cosines in the h_x equation with sines to get the h_y equation. The loop equations always have this form. This makes the equations very easy to derive. In a CAD implementation, equation generation may be automated.

The h_q equations are the sum of relative rotations from one vector to the next as you proceed around the loop. Counterclockwise rotations are positive. Fig. 13-17 traces the relative rotations for Loop 1. A final rotation of 180 is added to bring the rotations to closure.

While the arguments of the sines and cosines in the h_x and h_y equations represent the absolute angle from the x -axis, the angles are expressed as the sum of relative rotations up to that point in the loop. Using relative rotations is critical to the correct assembly model behavior. It allows rotational variations to propagate correctly through the assembly.

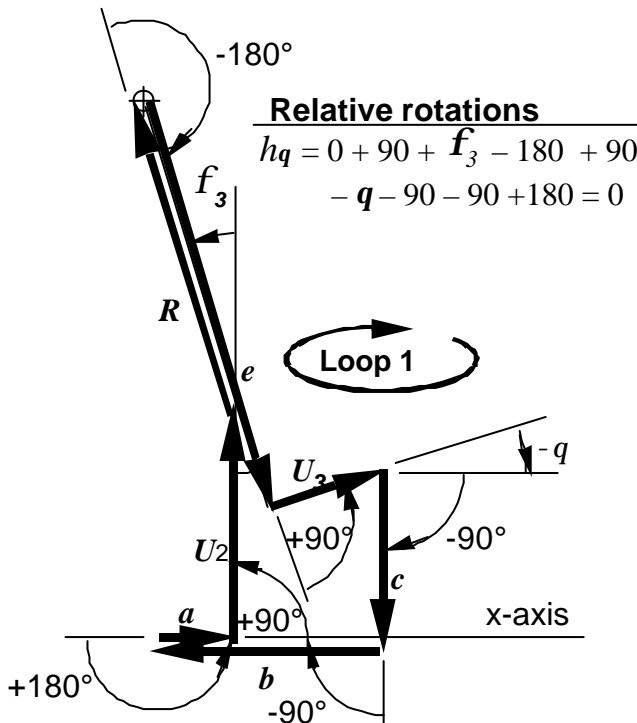

Figure 13-17 Relative rotations for Loop 1

A shortcut was used for the arguments for vectors U_2 , c , and b . The sum of relative rotations was replaced with their known absolute directions. The sum of relative angles for U_2 is $(-\mathbf{q}_1 - \mathbf{q}_2 + 90)$, but it must align with the angled plane of the frame (\mathbf{q}). Similarly, vectors b and c will always be vertical and horizontal, respectively, regardless of the preceding rotational variations in the loop. Replacing the angles for U , C , and b is equivalent to solving the h_q equation for \mathbf{q} and substituting in the arguments to eliminate some of the angle variables. If you try it both ways, you will see that you get the same results for the predicted variations. The results are also independent of the starting point of the loop. We could have started with any vector in the loop.

Step 2. Calculate derivatives and form matrix equations

The loop equations are nonlinear and implicit. They contain products and trigonometric functions of the variables. To solve for the assembly variables in this system of equations would require a nonlinear equation solver. Fortunately, we are only interested in the change in assembly variables for small changes in the components. This is readily accomplished by linearizing the equations by a first-order Taylor's series expansion.

Eq. (13.4) shows the linearized equations for Loop 1.

$$\begin{aligned}
 dh_x &= \frac{\partial h_x}{\partial a} da + \frac{\partial h_x}{\partial b} db + \frac{\partial h_x}{\partial c} dc + \frac{\partial h_x}{\partial e} de + \frac{\partial h_x}{\partial r} dr + \frac{\partial h_x}{\partial R} dR + \frac{\partial h_x}{\partial \mathbf{q}} d\mathbf{q} \\
 &+ \frac{\partial h_x}{\partial \mathbf{f}_1} d\mathbf{f}_1 + \frac{\partial h_x}{\partial \mathbf{f}_2} d\mathbf{f}_2 + \frac{\partial h_x}{\partial \mathbf{f}_3} d\mathbf{f}_3 + \frac{\partial h_x}{\partial U_1} dU_1 + \frac{\partial h_x}{\partial U_2} dU_2 + \frac{\partial h_x}{\partial U_3} dU_3 \\
 dh_y &= \frac{\partial h_y}{\partial a} da + \frac{\partial h_y}{\partial b} db + \frac{\partial h_y}{\partial c} dc + \frac{\partial h_y}{\partial e} de + \frac{\partial h_y}{\partial r} dr + \frac{\partial h_y}{\partial R} dR + \frac{\partial h_y}{\partial \mathbf{q}} d\mathbf{q} \\
 &+ \frac{\partial h_y}{\partial \mathbf{f}_1} d\mathbf{f}_1 + \frac{\partial h_y}{\partial \mathbf{f}_2} d\mathbf{f}_2 + \frac{\partial h_y}{\partial \mathbf{f}_3} d\mathbf{f}_3 + \frac{\partial h_y}{\partial U_1} dU_1 + \frac{\partial h_y}{\partial U_2} dU_2 + \frac{\partial h_y}{\partial U_3} dU_3 \\
 dh_z &= \frac{\partial h_z}{\partial a} da + \frac{\partial h_z}{\partial b} db + \frac{\partial h_z}{\partial c} dc + \frac{\partial h_z}{\partial e} de + \frac{\partial h_z}{\partial r} dr + \frac{\partial h_z}{\partial R} dR + \frac{\partial h_z}{\partial \mathbf{q}} d\mathbf{q} \\
 &+ \frac{\partial h_z}{\partial \mathbf{f}_1} d\mathbf{f}_1 + \frac{\partial h_z}{\partial \mathbf{f}_2} d\mathbf{f}_2 + \frac{\partial h_z}{\partial \mathbf{f}_3} d\mathbf{f}_3 + \frac{\partial h_z}{\partial U_1} dU_1 + \frac{\partial h_z}{\partial U_2} dU_2 + \frac{\partial h_z}{\partial U_3} dU_3
 \end{aligned} \tag{13.4}$$

where

$d\mathbf{a}$ represents a small change in dimension a , and so on.

Note that the terms have been rearranged, grouping the component variables a , b , c , e , r , R , and \mathbf{q} together and assembly variables U_1 , U_2 , U_3 , \mathbf{f}_1 , \mathbf{f}_2 , and \mathbf{f}_3 together. The Loop 2 and Loop 3 equations may be expressed similarly.

Performing the partial differentiation of the respective h_x , h_y , and h_q equations yields the coefficients of the linear system of equations. The partials are easy to perform because there are only sines and cosines to deal with. Eq. (13.5) shows the partials of the Loop 1 h_x equation.

Component Variables

Assembly Variables

$$\begin{array}{ll}
 \frac{\partial h_x}{\partial a} = \cos(0) & \frac{\partial h_x}{\partial f_1} = 0 \\
 \frac{\partial h_x}{\partial b} = \cos(-180) & \frac{\partial h_x}{\partial f_2} = 0 \\
 \frac{\partial h_x}{\partial c} = \cos(-90) & \frac{\partial h_x}{\partial f_3} = -R \sin(90+f_3) - e \sin(270+f_3) \\
 \frac{\partial h_x}{\partial e} = \cos(270+f_3) & \frac{\partial h_x}{\partial U_1} = 0 \\
 \frac{\partial h_x}{\partial r} = 0 & \frac{\partial h_x}{\partial U_2} = \cos(90) \\
 \frac{\partial h_x}{\partial R} = \cos(90+f_3) & \frac{\partial h_x}{\partial U_3} = \cos(?) \\
 \frac{\partial h_x}{\partial ?} = -U_3 \sin(?) &
 \end{array} \tag{13.5}$$

Each partial is evaluated at the nominal value of all dimensions. The nominal component dimensions are known from the engineering drawings or CAD model. The nominal assembly values may be obtained by querying the CAD model.

The partial derivatives above are not the tolerance sensitivities we seek, but they can be used to obtain them.

Step 3. Solve for assembly tolerance sensitivities

The linearized loop equations may be written in matrix form and solved for the tolerance sensitivities by matrix algebra. The six closed loop scalar equations can be expressed in matrix form as follows:

$$[A]\{\mathbf{dX}\} + [B]\{\mathbf{dU}\} = \{0\}$$

where:

- [A] is the matrix of partial derivatives with respect to the component variables,
- [B] is the matrix of partial derivatives with respect to the assembly variables,
- {dX} is the vector of small variations in the component dimensions, and
- {dU} is the vector of corresponding closed loop assembly variations.

We can solve for the closed loop assembly variations in terms of the component variations by matrix algebra:

$$\{\mathbf{dU}\} = -[B^{-1}A]\{\mathbf{dX}\} \tag{13.6}$$

The matrix $[B^{-1}A]$ is the matrix of tolerance sensitivities for the closed loop assembly variables. Performing the inverse of the matrix [B] and multiplying $[B^{-1}A]$ may be carried out using a spreadsheet or other math utility program on a desktop computer or programmable calculator.

For the example assembly, the resulting matrices and vectors for the closed loop solution are:

$$\{dX\} = \begin{Bmatrix} da \\ db \\ dc \\ de \\ dr \\ dR \\ dq \end{Bmatrix} \quad \{dU\} = \begin{Bmatrix} dU_1 \\ dU_2 \\ dU_3 \\ df_1 \\ df_2 \\ df_3 \end{Bmatrix}$$

$$[A] = \begin{bmatrix} \frac{\partial h_x}{\partial a} & \frac{\partial h_x}{\partial b} & \frac{\partial h_x}{\partial c} & \frac{\partial h_x}{\partial e} & \frac{\partial h_x}{\partial r} & \frac{\partial h_x}{\partial R} & \frac{\partial h_x}{\partial ?} \\ \frac{\partial h_y}{\partial a} & \frac{\partial h_y}{\partial b} & \frac{\partial h_y}{\partial c} & \frac{\partial h_y}{\partial e} & \frac{\partial h_y}{\partial r} & \frac{\partial h_y}{\partial R} & \frac{\partial h_y}{\partial ?} \\ \frac{\partial a}{\partial h_?} & \frac{\partial b}{\partial h_?} & \frac{\partial c}{\partial h_?} & \frac{\partial e}{\partial h_?} & \frac{\partial r}{\partial h_?} & \frac{\partial R}{\partial h_?} & \frac{\partial ?}{\partial h_?} \\ \frac{\partial a}{\partial h_x} & \frac{\partial b}{\partial h_x} & \frac{\partial c}{\partial h_x} & \frac{\partial e}{\partial h_x} & \frac{\partial r}{\partial h_x} & \frac{\partial R}{\partial h_x} & \frac{\partial ?}{\partial h_x} \\ \frac{\partial a}{\partial h_y} & \frac{\partial b}{\partial h_y} & \frac{\partial c}{\partial h_y} & \frac{\partial e}{\partial h_y} & \frac{\partial r}{\partial h_y} & \frac{\partial R}{\partial h_y} & \frac{\partial ?}{\partial h_y} \\ \frac{\partial a}{\partial h_?} & \frac{\partial b}{\partial h_?} & \frac{\partial c}{\partial h_?} & \frac{\partial e}{\partial h_?} & \frac{\partial r}{\partial h_?} & \frac{\partial R}{\partial h_?} & \frac{\partial ?}{\partial h_?} \\ \frac{\partial a}{\partial a} & \frac{\partial b}{\partial b} & \frac{\partial c}{\partial c} & \frac{\partial e}{\partial e} & \frac{\partial r}{\partial r} & \frac{\partial R}{\partial R} & \frac{\partial ?}{\partial ?} \end{bmatrix}$$

$$= \begin{bmatrix} 1 & -1 & 0 & \cos(270 + \mathbf{f}_3) & 0 & \cos(90 + \mathbf{f}_3) & -U_3 \sin(\mathbf{q}) \\ 0 & 0 & -1 & \sin(270 + \mathbf{f}_3) & 0 & \sin(90 + \mathbf{f}_3) & U_3 \cos(\mathbf{q}) \\ 0 & 0 & 0 & 0 & 0 & 0 & -1 \\ 1 & -1 & 0 & \cos(-\mathbf{f}_1 - \mathbf{f}_2) & 1 + \cos(-\mathbf{f}_1) & \cos(-\mathbf{f}_1 + 180) & -U_3 \sin(\mathbf{q}) \\ 0 & 0 & -1 & \sin(-\mathbf{f}_1 - \mathbf{f}_2) & \sin(-\mathbf{f}_1) & \sin(-\mathbf{f}_1 + 180) & U_3 \cos(\mathbf{q}) \\ 0 & 0 & 0 & 0 & 0 & 0 & -1 \end{bmatrix}$$

$$= \begin{bmatrix} 1 & -1 & 0 & .2924 & 0 & -.2924 & -4.7738 \\ 0 & 0 & -1 & -.9563 & 0 & .9563 & 15.6144 \\ 0 & 0 & 0 & 0 & 0 & 0 & -1 \\ 1 & -1 & 0 & .2924 & 1.7232 & -.7232 & -4.7738 \\ 0 & 0 & -1 & -.9563 & -.6907 & .6907 & 15.6144 \\ 0 & 0 & 0 & 0 & 0 & 0 & -1 \end{bmatrix}$$

$$[B] = \begin{bmatrix} \frac{\partial h_x}{\partial U_1} & \frac{\partial h_x}{\partial U_2} & \frac{\partial h_x}{\partial U_3} & \frac{\partial h_x}{\partial f_1} & \frac{\partial h_x}{\partial f_2} & \frac{\partial h_x}{\partial f_3} \\ \frac{\partial h_y}{\partial U_1} & \frac{\partial h_y}{\partial U_2} & \frac{\partial h_y}{\partial U_3} & \frac{\partial h_y}{\partial f_1} & \frac{\partial h_y}{\partial f_2} & \frac{\partial h_y}{\partial f_3} \\ \frac{\partial h_z}{\partial U_1} & \frac{\partial h_z}{\partial U_2} & \frac{\partial h_z}{\partial U_3} & \frac{\partial h_z}{\partial f_1} & \frac{\partial h_z}{\partial f_2} & \frac{\partial h_z}{\partial f_3} \\ \frac{\partial h_x}{\partial U_1} & \frac{\partial h_x}{\partial U_2} & \frac{\partial h_x}{\partial U_3} & \frac{\partial h_x}{\partial f_1} & \frac{\partial h_x}{\partial f_2} & \frac{\partial h_x}{\partial f_3} \\ \frac{\partial h_y}{\partial U_1} & \frac{\partial h_y}{\partial U_2} & \frac{\partial h_y}{\partial U_3} & \frac{\partial h_y}{\partial f_1} & \frac{\partial h_y}{\partial f_2} & \frac{\partial h_y}{\partial f_3} \\ \frac{\partial h_z}{\partial U_1} & \frac{\partial h_z}{\partial U_2} & \frac{\partial h_z}{\partial U_3} & \frac{\partial h_z}{\partial f_1} & \frac{\partial h_z}{\partial f_2} & \frac{\partial h_z}{\partial f_3} \end{bmatrix}$$

$$= \begin{bmatrix} 0 & \cos(90) & \cos(\mathbf{q}) & 0 & 0 & \begin{bmatrix} -R\sin(90+\mathbf{f}_3) - e\sin(270+\mathbf{f}_3) \\ R\cos(90+\mathbf{f}_3) + e\cos(270+\mathbf{f}_3) \end{bmatrix} \\ 0 & \sin(90) & \sin(\mathbf{q}) & 0 & 0 & 1 \\ 0 & 0 & 0 & \begin{bmatrix} r\sin(-\mathbf{f}_1) \\ R\sin(180-\mathbf{f}_1) \\ e\sin(-\mathbf{f}_1-\mathbf{f}_2) \end{bmatrix} & e\sin(-\mathbf{f}_1-\mathbf{f}_2) & 0 \\ \cos(90) & 0 & \cos(\mathbf{q}) & \begin{bmatrix} -r\cos(-\mathbf{f}_1) \\ -R\cos(180-\mathbf{f}_1) \\ -e\cos(-\mathbf{f}_1-\mathbf{f}_2) \end{bmatrix} & -e\cos(-\mathbf{f}_1-\mathbf{f}_2) & 0 \\ \sin(90) & 0 & \sin(\mathbf{q}) & -1 & -1 & 0 \\ 0 & 0 & 0 & -1 & -1 & 0 \end{bmatrix}$$

$$= \begin{bmatrix} 0 & 0 & .95631 & 0 & 0 & 14.3446 \\ 0 & 1 & .29237 & 0 & 0 & 4.3856 \\ 0 & 0 & 0 & 0 & 0 & 1 \\ 0 & 0 & .95631 & -31.8764 & -52.5968 & 0 \\ 1 & 0 & .29237 & 5.6144 & -16.0804 & 0 \\ 0 & 0 & 0 & -1 & -1 & 0 \end{bmatrix}$$

$$[B^{-1}] = \begin{bmatrix} .7413 & 0 & -10.6337 & -1.0470 & 1 & 38.9901 \\ -.3057 & 1 & 0 & 0 & 0 & 0 \\ 1.0457 & 0 & -15 & 0 & 0 & 0 \\ -.0483 & 0 & .6923 & .0483 & 0 & -2.5384 \\ .0483 & 0 & -.6923 & -.0483 & 0 & 1.5384 \\ 0 & 0 & 1 & 0 & 0 & 0 \end{bmatrix}$$

$$\{\mathbf{dU}\} = -[B^{-1}A]\{\mathbf{dX}\} \quad (13.7)$$

$$\begin{Bmatrix} \mathbf{dU}_1 \\ \mathbf{dU}_2 \\ \mathbf{dU}_3 \\ \mathbf{df}_1 \\ \mathbf{df}_2 \\ \mathbf{df}_3 \end{Bmatrix} = \begin{bmatrix} .3057 & -.3057 & 1 & 1.0457 & 2.494885 & -1.2311 & 11.2825 \\ .3057 & -.3057 & 1 & 1.0457 & -1 & -1.0457 & -17.0739 \\ -1.0457 & 1.0457 & 0 & -.3057 & 0 & .3057 & -10.0080 \\ 0 & 0 & 0 & 0 & -.0832 & .0208 & -1.8461 \\ 0 & 0 & 0 & 0 & .0832 & -.0208 & .8461 \\ 0 & 0 & 0 & 0 & 0 & 0 & 1 \end{bmatrix} \begin{Bmatrix} \mathbf{da} \\ \mathbf{db} \\ \mathbf{dc} \\ \mathbf{de} \\ \mathbf{dr} \\ \mathbf{dR} \\ \mathbf{dq} \end{Bmatrix}$$

Estimates for variation of the assembly performance requirements are obtained by linearizing the open loop equations by a procedure similar to the closed loop equations. In general, there will be a system of nonlinear scalar equations which may be linearized by Taylor's series expansion. Grouping terms as before, we can express the linearized equations in matrix form:

$$\{\mathbf{dV}\} = [C]\{\mathbf{dX}\} + [E]\{\mathbf{dU}\} \quad (13.8)$$

where

- $\{\mathbf{dV}\}$ is the vector of variations in the assembly performance requirements,
- $[C]$ is the matrix of partial derivatives with respect to the component variables,
- $[E]$ is the matrix of partial derivatives with respect to the assembly variables,
- $\{\mathbf{dX}\}$ is the vector of small variations in the component dimensions, and
- $\{\mathbf{dU}\}$ is the vector of corresponding closed loop assembly variations.

We can solve for the open loop assembly variations in terms of the component variations by matrix algebra, by substituting the results of the closed loop solution. Substituting for $\{\mathbf{dU}\}$:

$$\begin{aligned} \{\mathbf{dV}\} &= [C]\{\mathbf{dX}\} - [E][B^{-1}A]\{\mathbf{dX}\} \\ &= [C - EB^{-1}A]\{\mathbf{dX}\} \end{aligned}$$

The matrix $[C - EB^{-1}A]$ is the matrix of tolerance sensitivities for the open loop assembly variables. The $B^{-1}A$ terms come from the closed loop constraints on the assembly. The $B^{-1}A$ terms represent the effect of small internal kinematic adjustments occurring at assembly time in response to dimensional variations. The internal adjustments affect the $\{\mathbf{dV}\}$ as well as the $\{\mathbf{dU}\}$.

It is important to note that you cannot simply solve for the values of $\{\mathbf{dU}\}$ in Eq. (13.6) and substitute them directly into Eq. (13.8), as though $\{\mathbf{dU}\}$ were just another component variation. If you do, you are treating $\{\mathbf{dU}\}$ as though it is independent of $\{\mathbf{dX}\}$. But $\{\mathbf{dU}\}$ depends on $\{\mathbf{dX}\}$ through the closed loop constraints. You must evaluate the full matrix $[C - EB^{-1}A]$ to obtain the tolerance sensitivities. Allowing the $B^{-1}A$ terms to interact with C and E is necessary to determine the effect of the kinematic adjustments on $\{\mathbf{dV}\}$. Treating them separately is similar to taking the absolute value of each term, then summing for Worst Case, rather than summing like terms before taking the absolute value. The same is true for RSS analysis. It is similar to squaring each term, then summing, rather than summing like terms before squaring.

For the example assembly, the equation for $\{\mathbf{dV}\}$ reduces to a single scalar equation for the Gap variable.

$$\begin{aligned} dGap &= \frac{\partial Gap}{\partial a} da + \frac{\partial Gap}{\partial b} db + \frac{\partial Gap}{\partial c} dc + \frac{\partial Gap}{\partial e} de + \frac{\partial Gap}{\partial f} df + \frac{\partial Gap}{\partial g} dg \\ &+ \frac{\partial Gap}{\partial r} dr + \frac{\partial Gap}{\partial R} dR + \frac{\partial Gap}{\partial q} dq + \frac{\partial Gap}{\partial U_1} dU_1 + \frac{\partial Gap}{\partial U_2} dU_2 + \frac{\partial Gap}{\partial U_3} dU_3 \\ &+ \frac{\partial Gap}{\partial f_1} df_1 + \frac{\partial Gap}{\partial f_2} df_2 + \frac{\partial Gap}{\partial f_3} df_3 \end{aligned}$$

$$\begin{aligned} dGap &= [\sin(-90)+\sin(180)] d\mathbf{r} + \sin(90) d\mathbf{f} + \sin(0) d\mathbf{g} + \sin(-90)dU_1 \\ &= -d\mathbf{r} + d\mathbf{f} - dU_1 \end{aligned}$$

Substituting for dU_1 from the closed loop results (Eq. (13.7)) and grouping terms:

$$\begin{aligned} dGap &= -d\mathbf{r} + d\mathbf{f} - (.3057d\mathbf{a} - .3057d\mathbf{b} + d\mathbf{c} + 1.0457d\mathbf{e} + 2.4949d\mathbf{f} - 1.2311d\mathbf{R} + 11.2825d\mathbf{q}) \quad (13.9) \\ &= -.3057d\mathbf{a} + .3057d\mathbf{b} - d\mathbf{c} - 1.0457d\mathbf{e} - 3.4949d\mathbf{f} + 1.2311d\mathbf{R} - 11.2825d\mathbf{q} \end{aligned}$$

While Eq. (13.9) expresses the assembly variation $dGap$ in terms of the component variations $d\mathbf{X}$, it is not an estimate of the tolerance accumulation. To estimate accumulation, you must use a model, such as Worst Case or Root Sum Squares.

Step 4. Form Worst Case and RSS expressions

As has been shown earlier, estimates of tolerance accumulation for dU or dV may be calculated by summing the products of the tolerance sensitivities and component variations:

Worst Case

$$dU \text{ or } dV = \sum |S_{ij}| d\mathbf{x}_j$$

RSS

$$dU \text{ or } dV = \sqrt{\sum (S_{ij} d\mathbf{x}_j)^2}$$

S_{ij} is the tolerance sensitivities of assembly features to component variations. If the assembly variable of interest is a closed loop variable dU_p , S_{ij} is obtained from the appropriate row of the $B^{-1}A$ matrix. If dV_i is wanted, S_{ij} comes from the $[C-E B^{-1}A]$ matrix. If measured variation data are available, $d\mathbf{x}_j$ is the $\pm 3\sigma$ process variation. If production of parts has not begun, $d\mathbf{x}_j$ is usually taken to be equal to the $\pm 3\sigma$ design tolerances on the components.

In the example assembly, length U_1 is a closed loop assembly variable. U_1 determines the location of the contact point between the Cylinder and the Frame. To estimate the variation in U_p , we would multiply the first row of $[B^{-1}A]$ with $\{d\mathbf{X}\}$ and sum by Worst Case or RSS.

Worst Case:

$$\begin{aligned} dU_1 &= |S_{11}|d\mathbf{a} + |S_{12}|d\mathbf{b} + |S_{13}|d\mathbf{c} + |S_{14}|d\mathbf{e} + |S_{15}|d\mathbf{f} + |S_{16}|d\mathbf{R} + |S_{17}|d\mathbf{q} \\ &= |.3057| 0.3 + |-.3057| 0.3 + |1| 0.3 + |1.0457| 0.3 + |2.4949| 0.1 + |-1.2311| 0.3 + |11.2825| 0.01745 \\ &= \pm 1.6129 \text{ mm} \end{aligned}$$

RSS:

$$\begin{aligned}
 dU_1 &= [(S_{11}d\mathbf{a})^2 + (S_{12}d\mathbf{b})^2 + (S_{13}d\mathbf{c})^2 + (S_{14}d\mathbf{e})^2 + (S_{15}d\mathbf{r})^2 + (S_{16}d\mathbf{R})^2 + (S_{17}d\mathbf{q})^2]^{.5} \\
 &= [(.3057 \cdot 0.3)^2 + (-.3057 \cdot 0.3)^2 + (1 \cdot 0.3)^2 + (1.0457 \cdot 0.3)^2 + (2.4949 \cdot 0.1)^2 + (-1.2311 \cdot 0.3)^2 + \\
 &\quad (11.2825 \cdot 0.01745)^2]^{.5} \\
 &= \pm 0.6653 \text{ mm}
 \end{aligned}$$

Note that the tolerance on q has been converted to ± 0.01745 radians since the sensitivity is calculated per radian.

For the variation in the Gap, we would multiply the first row of $[C-EB^{-1}A]$ with $\{d\mathbf{X}\}$ and sum by Worst Case or RSS. Vector $\{d\mathbf{X}\}$ is extended to include $d\mathbf{f}$ and $d\mathbf{g}$.

Worst Case:

$$\begin{aligned}
 dGap &= |S_{11}|d\mathbf{a} + |S_{12}|d\mathbf{b} + |S_{13}|d\mathbf{c} + |S_{14}|d\mathbf{e} + |S_{15}|d\mathbf{r} + |S_{16}|d\mathbf{R} + |S_{17}|d\mathbf{q} + |S_{18}|d\mathbf{f} + |S_{19}|d\mathbf{g} \\
 &= |-.30573| 0.3 + |.30573| 0.3 + |-1| 0.3 + |-1.04569| 0.3 + |-3.4949| 0.1 + |1.2311| 0.3 \\
 &\quad + |-11.2825| 0.01745 + |1| 0.5 + |0| 0 \\
 &= \pm 2.2129 \text{ mm}
 \end{aligned}$$

RSS:

$$\begin{aligned}
 dGap &= [(S_{11}d\mathbf{a})^2 + (S_{12}d\mathbf{b})^2 + (S_{13}d\mathbf{c})^2 + (S_{14}d\mathbf{e})^2 + (S_{15}d\mathbf{r})^2 + (S_{16}d\mathbf{R})^2 + (S_{17}d\mathbf{q})^2 + (S_{18}d\mathbf{f})^2 + (S_{19}d\mathbf{g})^2]^{.5} \\
 &= [(-.30573 \cdot 0.3)^2 + (.30573 \cdot 0.3)^2 + (-1 \cdot 0.3)^2 + (-1.04569 \cdot 0.3)^2 + (-3.4949 \cdot 0.1)^2 + (1.2311 \cdot 0.3)^2 \\
 &\quad + (-11.2825 \cdot 0.01745)^2 + (1 \cdot 0.5)^2 + (0 \cdot 0)^2]^{.5} \\
 &= \pm 0.8675 \text{ mm}
 \end{aligned}$$

By forming similar expressions, we may obtain estimates for all the assembly variables (Table 13-1).

Table 13-1 Estimated variation in open and closed loop assembly features

Assembly Variable	Mean or Nominal	WC	RSS
		$\pm d_{TJ}$	$\pm d_{TJ}$
U_1	59.0026 mm	1.6129 mm	0.6653 mm
U_2	41.4708 mm	1.5089 mm	0.6344 mm
U_3	16.3279 mm	0.9855 mm	0.4941 mm
f_1	43.6838°	2.68°	1.94°
f_2	29.3162°	1.68°	1.04°
f_3	17.0000°	1.00°	1.00°
Gap	5.9974 mm	2.2129 mm	0.8675 mm

Step 5. Evaluation and design iteration

The results of the variation analysis are evaluated by comparing the predicted variation with the specified design requirement. If the variation is greater or less than the specified assembly tolerance, the expressions can be used to help decide which tolerances to tighten or loosen.

13.5.5.1 Percent Rejects

The percent rejects may be estimated from Standard Normal tables by calculating the number of standard deviations from the mean to the upper and lower limits (UL and LL).

13-22 Chapter Thirteen

The only assembly feature with a performance requirement is the Gap. The acceptable range for proper performance is: Gap = 6.00 ±1.00 mm. Calculating the distance from the mean Gap to UL and LL in units equal to the standard deviation of the Gap:

$$Z_{UL} = \frac{UL - \mu_{Gap}}{\sigma_{Gap}} = \frac{7.000 - 5.9974}{0.2892} = 3.467 \sigma \quad R_{UL} = 263 \text{ ppm}$$

$$Z_{LL} = \frac{LL - \mu_{Gap}}{\sigma_{Gap}} = \frac{5.000 - 5.9974}{0.2892} = -3.449 \sigma \quad R_{LL} = 281 \text{ ppm}$$

The total predicted rejects are 544 ppm.

13.5.5.2 Percent Contribution Charts

The percent contribution chart tells the designer how each dimension contributes to the total Gap variation. The contribution includes the effect of both the sensitivity and the tolerance. The calculation is different for Worst Case or RSS variation estimates.

Worst Case

RSS

$$\% \text{ Cont} = \frac{\left| \frac{\partial \text{Gap}}{\partial x_j} \cdot dx_j \right|}{\sum \left| \frac{\partial \text{Gap}}{\partial x_i} \cdot dx_i \right|}$$

$$\% \text{ Cont} = \frac{\left(\frac{\partial \text{Gap}}{\partial x_j} \cdot dx_j \right)^2}{\sum \left(\frac{\partial \text{Gap}}{\partial x_i} \cdot dx_i \right)^2}$$

It is common practice to present the results as a bar chart, sorted according to magnitude. The results for the sample assembly are shown in Fig. 13-18.

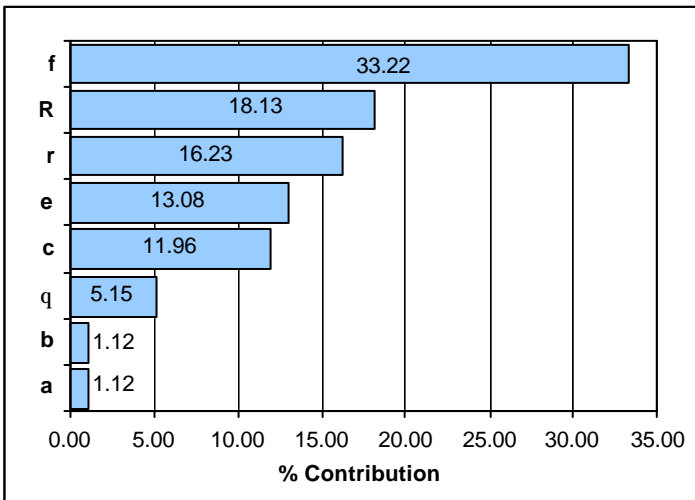

Figure 13-18 Percent contribution chart for the sample assembly

It is clear that the outside dimension of the Gap, f , is the principal contributor, followed by the radius R . This plot shows the designer where to focus design modification efforts.

Simply changing the tolerances on a few dimensions can change the chart dramatically. Suppose we tighten the tolerance on f , since it is relatively easy to control, and loosen the tolerances on R and e , since they are more difficult to locate and machine with precision. We will say the Cylinder is vendor-supplied, so it cannot be modified. Table 13-2 shows the new tolerances.

Table 13-2 Modified dimensional tolerance specifications

Dimension	±Tolerance	
	Original	Modified
a	0.3 mm	0.3 mm
b	0.3 mm	0.3 mm
c	0.3 mm	0.3 mm
e	0.3 mm	0.4 mm
r	0.1 mm	0.1 mm
R	0.3 mm	0.4 mm
q	1.0°	1.0°
f	0.5 mm	0.4 mm

Now, R and e are the leading contributors, while f has dropped to third. Of course, changing the tolerances requires modification of the processes. See Fig. 13-19. Tightening the tolerance on f , for example, might require changing the feed or speed or number of finish passes on a mill.

Since it is the product of the sensitivity times the tolerance that determines the percent contribution, the sensitivity is also an important variation evaluation aid.

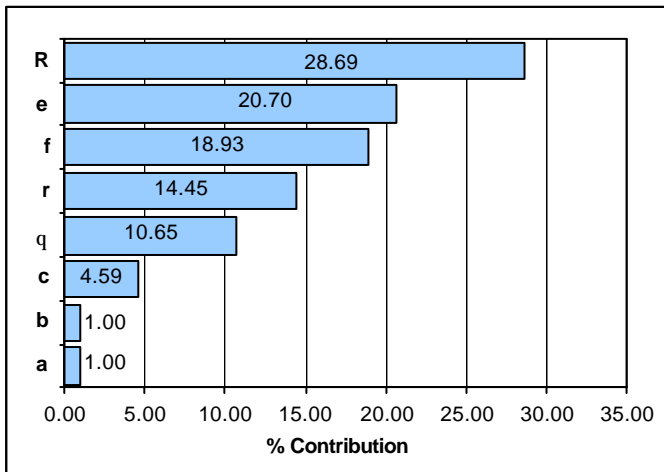

Figure 13-19 Percent contribution chart for the sample assembly with modified tolerances

13.5.5.3 Sensitivity Analysis

The tolerance sensitivities tell how the arrangement of the parts and the geometry contribute to assembly variation. We can learn a great deal about the role played by each dimension by examining the sensitivities. For the sample assembly, Table 13-3 shows the calculated Gap sensitivities.

Table 13-3 Calculated sensitivities for the Gap

Dimension	Sensitivity
a	-0.3057
b	0.3057
c	-1.0
e	-1.0457
r	-3.4949
R	1.2311
q	-11.2825
f	1.0

Note that the sensitivity of q is calculated per radian.

For a 1.0 mm change in a or b , the Gap will change by 0.3057 mm. The negative sign for a means the Gap will decrease as a increases. For each mm increase in c , the Gap decreases an equal amount. This behavior becomes clear on examining Fig. 13-12. As a increases 1.0 mm, the Block is pushed up the inclined plane, raising the Block and Cylinder by the $\tan(17^\circ)$ or 0.3057 and decreasing the Gap. As b increases 1.0 mm, the plane is pushed out from under the Block, causing it to lower the same amount. Increasing c 1.0 mm, causes everything to slide straight up, decreasing the Gap.

Dimensions e , r , R , and q are more complex because several adjustments occur simultaneously. As r increases, the Cylinder grows, causing it to slide up the wall, while maintaining contact with the concave surface of the Block. As the Cylinder rises, the Gap decreases. As R increases, the concave surface moves deeper into the block, causing the Cylinder to drop, which increases the Gap. Increasing e causes the Block to thicken, forcing the front corner up the wall and pushing the Block up the plane. The net effect is to raise the concave surface, decreasing the Gap. Increasing q causes the Block to rotate about the front edge of the inclined plane, while the front corner slides down the wall. The wedge angle between the concave surface and the wall decreases, squeezing the Cylinder upward and decreasing the Gap. The large sensitivities for r and q are offset by their small corresponding tolerances.

13.5.5.4 Modifying Geometry

The most common geometry modification is to change the nominal values of one or more dimensions to center the nominal value of a gap between its UL and LL. For example, if we wanted to change the Gap specifications to be 5.00 ± 1.000 mm, we could simply increase the nominal value of c by 1.00 mm. Since the sensitivity of the Gap to c is -1.0 , the Gap will decrease by 1.0 mm.

Similarly, the sensitivities may be modified by changing the geometry. Since the sensitivities are partial derivatives, which are evaluated at the nominal values of the component dimensions, they can only be changed by changing the nominal values. An interesting exercise is to modify the geometry of the example assembly to make the Gap insensitive to variation in q ; that is, to make the sensitivity of q go to zero. You will need nonlinear equation solver software to solve the original loop equations (Eqs. (13-4), (13-5), and (13-6)), for a new set of nominal assembly values. Solve for the kinematic assembly variables: U_1 , U_2 , U_3 , f_1 , f_2 , and f_3 , corresponding to your new nominal dimensions: a , b , c , e , r , R , q , f , and Gap.

The sensitivity of q will decrease to nearly zero if we increase b to a value of 40 mm. We must also increase c to 35 mm to reduce the nominal Gap back to 6.00 mm. The [A], [B], [C], and [E] matrices will all need to be re-evaluated and solved for the variations. The modified results are shown in Table 13-4.

Table 13-4 Calculated sensitivities for the Gap after modifying geometry

Dimension	Nominal	\pm Tolerance	Sensitivity
a	10 mm	0.3	-0.3057
b	40 mm	0.3	0.3057
c	35 mm	0.3	-1.0
e	55 mm	0.4	-1.0457
r	10 mm	0.1	-3.4949
R	40 mm	0.4	1.2311
q	17°	1.0°	-0.3478
f	75 mm	0.4	1.0

Notice that the only sensitivity to change was q (per radian). This is due to the lack of coupling of b and c with the other variables. The calculated variations are shown in Table 13-5.

Table 13-5 Variation results for modified nominal geometry

Assembly Variable	Mean or Nominal	WC	RSS
		$\pm d_U$	$\pm d_U$
U_1	59.0453 mm	1.6497 mm	0.7659 mm
U_2	41.5135 mm	1.9088 mm	0.8401 mm
U_3	26.7848 mm	0.9909 mm	0.4908 mm
f_1	43.6838°	2.80°	1.97°
f_2	29.3162°	1.80°	1.08°
f_3	17°	1.00°	1.00°
Gap	5.9547 mm	2.1497 mm	0.8980 mm

The new percent contribution chart is shown in Fig. 13-20. Based on the low sensitivity, you could now increase the tolerance on q without affecting the Gap variation.

Step 6. Report results and document changes

The final step in the assembly tolerance analysis procedure is to prepare the final report. Figures, graphs, and tables are preferred. Comparison tables and graphs will help to justify design decisions. If you have several iterations, it is wise to adopt a case numbering scheme to identify each table and graph with its corresponding case. A list of case numbers with a concise summary of the distinguishing feature for each would be appreciated by the reader.

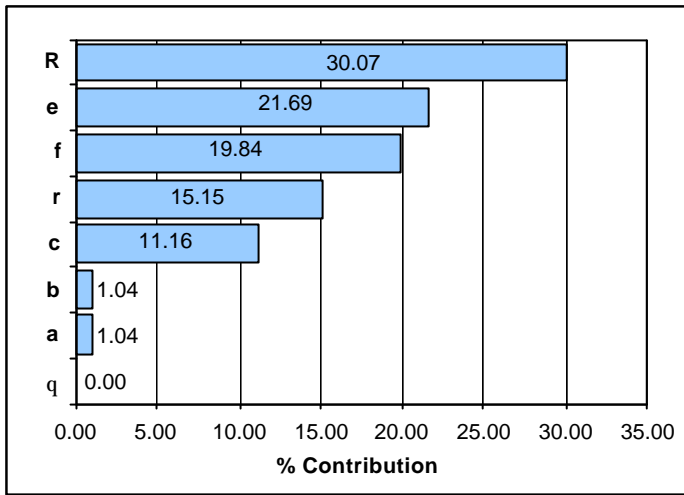

Figure 13-20 Modified geometry yields zero *q* contribution

13.6 Summary

The preceding sections have presented a systematic procedure for modeling and analyzing assembly variation. Some of the advantages of the modeling system include:

- The three main sources of variation may be included: dimensions; geometric form, location, and orientation; and kinematic adjustments.
- Assembly models are constructed of vectors and kinematic joints, elements with which most designers are familiar.
- A variety of assembly configurations may be represented with a few basic elements.
- Modeling rules guide the designer and assist in the creation of valid models.
- It can be automated and integrated with a CAD system to achieve fully graphical model creation.

Advantages of the analysis system include:

- The assembly functions are readily derived from the graphical model.
- Nonlinear, implicit systems of equations are readily converted to a linear system. Tolerance sensitivities are determined by a single, standard, matrix algebra operation.
- Statistical algorithms estimate tolerance stackup accurately and efficiently without requiring repeated simulations.
- Once expressions for the variation in assembly features have been derived, they may be used for tolerance allocation or “what-if?” studies without repeating the assembly analysis.
- Variation parameters useful for evaluation and design are easily obtained, such as: the mean and standard deviation of critical assembly features, sensitivity and percent contribution of each component dimension and geometric form variation, percent rejects, and quality level.
- Tolerance analysis models combine design requirements with process capabilities to foster open communication between design and manufacturing and reasoned, quantitative decisions.
- It can be automated to totally eliminate manual derivation of equations or equation typing.

A CAD-based tolerance analysis system based on the procedures demonstrated previously has been developed. The basic organization of the Computer-Aided Tolerancing System (CATS) is shown schematically in Fig. 13-21. The system has been integrated with a commercial 3-D CAD system, so it looks and feels like the designer's own system. Many of the manual tasks of modeling and analysis described above have been converted to graphical functions or automated.

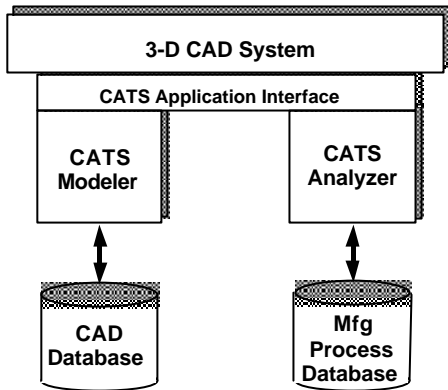

Figure 13-21 The CATS System

Tolerance analysis has become a mature engineering design tool. It is a quantitative tool for concurrent engineering. Powerful statistical algorithms have been combined with graphical modeling and evaluation aids to assist designers by bringing manufacturing considerations into their design decisions. Process selection, tooling, and inspection requirements may be determined early in the product development cycle. Performing tolerance analysis on the CAD model creates a virtual prototype for identifying variation problems before parts are produced. Designers can be much more effective by designing assemblies that work in spite of manufacturing process variations. Costly design changes to accommodate manufacturing can be reduced. Product quality and customer satisfaction can be increased. Tolerance analysis could become a key factor in maintaining competitiveness in today's international markets.

13.7 References

1. Carr, Charles D. 1993. "A Comprehensive Method for Specifying Tolerance Requirements for Assemblies." Master's thesis. Brigham Young University.
2. Chase, K. W. and A. R. Parkinson. 1991. A Survey of Research in the Application of Tolerance Analysis to the Design of Mechanical Assemblies. *Research in Engineering Design*. 3(1): 23-37.
3. Chase, K. W. and Angela Trego. 1994. *AutoCATS Computer-Aided Tolerancing System - Modeler User Guide*. ADCATS Report, Brigham Young University.
4. Chase, K. W., J. Gao and S. P. Magleby. 1995. General 2-D Tolerance Analysis of Mechanical Assemblies with Small Kinematic Adjustments. *Journal of Design and Manufacturing*. 5(4):263-274.
5. Chase, K. W., J. Gao and S. P. Magleby. 1998. Tolerance Analysis of 2-D and 3-D Mechanical Assemblies with Small Kinematic Adjustments. In *Advanced Tolerancing Techniques*. pp. 103-137. New York: John Wiley.
6. Chase, K. W., J. Gao, S. P. Magleby and C. D. Sorenson. 1996. Including Geometric Feature Variations in Tolerance Analysis of Mechanical Assemblies. *IIE Transactions*. 28(10): 795-807.
7. Fortini, E.T. 1967. *Dimensioning for Interchangeable Manufacture*. New York, New York: Industrial Press.
8. The American Society of Mechanical Engineers. 1995. *ASME Y14.5M-1994, Dimensioning and Tolerancing*. New York, New York: The American Society of Mechanical Engineers.