

---

# Chapter 24

## Pinned Interfaces

**Stephen Harry Werst**  
**Raytheon Systems Company**  
**Dallas, Texas**

*Mr. Werst has worked as a mechanical engineer with Texas Instruments Defense Systems and Electronics Group, now part of Raytheon Systems Company, for more than six years. Most of his work has involved the design of electro-optic infrared imaging systems and more recently, GD&T training. Mr. Werst attended the University of Texas at Arlington, graduating summa cum laude with a bachelor's degree in mechanical engineering. He recently earned his master's degree in engineering management from Southern Methodist University. Prior to his work with Raytheon, he worked as a computer programmer for Martin Marietta Energy Systems.*

### 24.1 List of Symbols (Definitions and Terminology)

<b><i>a</i></b>	Rotation error between parts
<b><i>b</i></b>	Installation angle of modified alignment pins
<b><i>d</i></b>	Translation error between parts
<b><i>s</i></b>	Standard deviation
$\emptyset_h$ or $\emptyset_{h1}$ and $\emptyset_{h2}$	The diameter of the clearance hole(s) or the diameters of the first and second clearance holes
$\emptyset_p$ or $\emptyset_{p1}$ and $\emptyset_{p2}$	The diameter of the alignment pin(s) or the diameters of the first and second alignment pins
<b><i>c</i></b>	A measure of the clearance between alignment features in an assembly
<b><i>c<sub>nom</sub></i></b>	The clearance calculated using the nominal dimensions
<b><i>cte</i></b>	Coefficient of thermal expansion

## 24-2 Chapter Twenty-four

$d_e$	Distance between the center of the clearance hole and the edge of the part
$d_h$	Distance between the centers of the clearance holes
$d_{hs}$	Distance between the center of the hole and the center of the slot
$d_p$	Distance between the centers of the alignment pins
$d_{px}$	Distance between the centers of the alignment pins in the x direction
$d_{py}$	Distance between the centers of the alignment pins in the y direction
$l_{slot}$	Length of slot
$perp_h$ or $perp_{h1}$ and $perp_{h2}$	Perpendicularity of the clearance hole(s) or the perpendicularity of the first and second clearance holes
$perp_p$ or $perp_{p1}$ and $perp_{p2}$	Perpendicularity of the alignment pin(s) or the perpendicularity of the first and second alignment pins
$t$	The distance from the center of the pin to the flat
$w_{slot}$	Width of slot

## 24.2 Introduction

The use of pins is the most common way of precisely controlling the alignment of mating parts. Even children's inexpensive plastic models use pins molded into the plastic to help maintain the alignment of the glued sections. There may be, however, as many different methods for dimensioning pinned interfaces as there are designs that use them. This section includes five of the more common design configurations using straight pins. Fit, rotation, and translation performance criteria along with Six Sigma dimensioning methodologies will be included for each configuration and manufacturing process. The reader can use this information to compare the differences in performance between the available options and choose the most appropriate one.

Ultimately, the goal of this section is to provide a common methodology for selecting and dimensioning a pin configuration. If implemented successfully, engineers with the same knowledge about the available pins and manufacturing processes will design similar assemblies identically. This standardization results in lower costs in several areas of the business. Although this section only presents alignment pins pressed into interference holes, these principles can be extended to other applications.

Before considering the method of aligning parts, the engineer must understand the requirements. Often the requirements handed down from customers are vague, so best estimates of actual requirements are needed. When making these estimates, keep in mind that "as good as we can do" too often is synonymous with "as expensive as we can make it." The goal of the design process should be to deliver a product to customers that meets their expectations at the lowest possible cost to the company. Since this chapter deals with making tradeoffs between performance and relative costs, it would be useless to the engineer wishing to design a product with only the best performance in mind.

## 24.3 Performance Considerations

Alignment pins typically have three performance requirements:

- The parts must fit together.
- The pins should minimize the permissible translation between the two parts.
- The pins should maintain orientation between the two parts.

These three performance criteria will be evaluated for each design configuration.

Unfortunately, the engineer must make a tradeoff between the first and the last two performance requirements, as they are mutually exclusive. In order to ensure the parts fit together, the clearance holes must have sufficient clearance to compensate for the positional variation of the pins and the holes. However, clearance between the holes and the pins degrades the ability to align the parts to one another. We must therefore balance the ability to assemble the parts against the alignment between the parts after assembly.

For all the design configurations in this section, the calculation of the rotational error at each interface can be simplified to take the form of the following equation:

$$\mathbf{a} = \frac{\text{constant}}{d_p} \quad (24.1)$$

where *constant* is a function of the design configuration and manufacturing processes. In all but one design configuration,  $d_p$  refers to the total distance between the two pins. In the case of two pins with one hole and edge contact, only the distance between the two pins in a direction parallel to the edge contact of the second pin is important. See Fig. 24-10.

Eq. (24.1) enables the development of tables of constants for design types, allocation methods, and manufacturing processes. Tables 24-3, 24-5, 24-7, 24-9, and 24-11 present these constants for various design types. These tables also include constants for translation.

## 24.4 Variation Components of Pinned Interfaces

Alignment pins contribute to the assembly performance variation in two ways:

- The movement due to clearances between the parts (interface error).
- The ability to locate the pins/clearance holes with respect to a datum reference frame (positional error).

If the design involves only two parts with critical placement requirements, we can eliminate the second source of variation by using the pins/clearance holes as the datums for the parts. However, many times we have three or more parts that must retain alignments with respect to each other and cannot avoid the error of positioning the pins relative to another set of pins.

### 24.4.1 Type I Error

Fig. 24-1 shows two similar designs for maintaining the alignment of the slots in parts 1 and 2. In the figure on the left, part 1 uses the clearance holes as the datum reference frame (DRF), and part 2 has the pins as the DRF. In addition to the variations of locating and orienting the slots to their respective DRFs, the alignment pin interface adds error caused by the clearance between the holes and the pins. Since this clearance is necessary for assembly, it cannot be eliminated. However, the pins and holes are the datums, so the design does not have additional variation of locating the holes and pins with respect to another DRF. This type of design has only Type I error consisting entirely of clearance between the alignment features.

### 24.4.2 Type II Error

The design on the right side of Fig. 24-1 adds two parts, 3 and 4, to provide additional separation between parts 1 and 2. Again, alignment between the slots in parts 1 and 2 is critical, so the two additional parts use alignment pins. Parts 2, 3, and 4 use the pins as their DRFs, and part 1 still uses the clearance holes as the DRF. As in the design on the left of the figure, the error between the slots includes the error of locating and orienting the slots to the DRFs of parts 1 and 2 and the errors induced by the tolerance stackup of alignment pins.

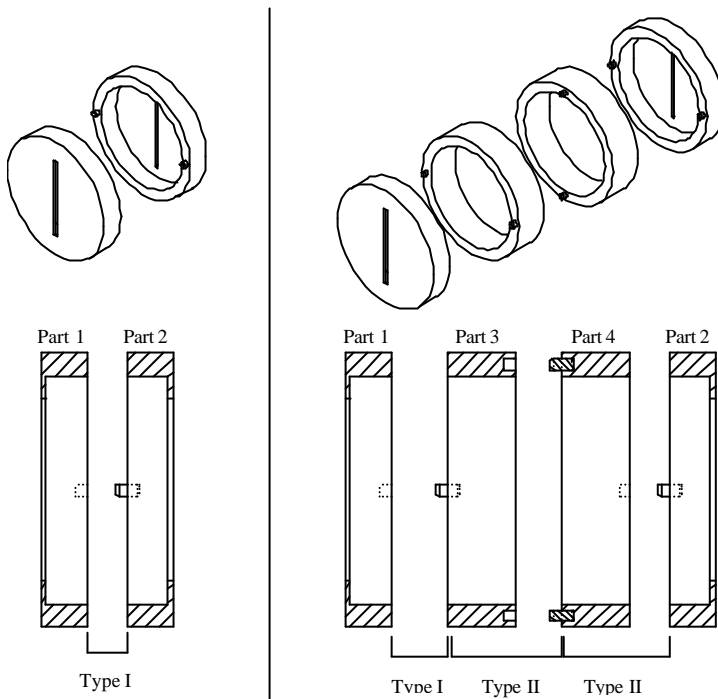

**Figure 24-1** Examples of design cases for alignment pins showing Type I and Type II errors

In this design, however, there are three alignment pin interfaces. The interface between parts 1 and 3 is identical to the single interface in the design on the left. Therefore, the error between parts 1 and 3 is Type I error. Though the interface between parts 3 and 4 appears to be the same as between parts 1 and 2, there is an additional contributor because the clearance holes on part 3 are not the datums. To determine the error between the DRF of part 3 and the DRF of part 4, we must include both the error at the pin interface due to clearance (similar to Type I error) and the error associated with locating the clearance holes of part 3 with respect to the pins of part 3. This combined error is called Type II error.

Most designs will have one Type I error and a Type II error component for each additional part beyond the initial two. It is possible to conceive of designs that don't follow this rule, but they are not as efficient at minimizing the total alignment variation between critical features. The engineer should therefore strive to follow this tolerancing methodology when using alignment pins.

## 24.5 Types of Alignment Pins

All the designs considered in this section use two pins to align mating parts. Before we can establish a set of common design characteristics for the different configurations of alignment pins, we must first determine the sets of pins to be used. For this book, we will use .0002" oversized pins defined in ANSI B18.8.2-1978, R1989 for the round pins as shown in Table 24-1.

In addition to the standard ANSI pins, some design configurations use one modified pin with one round pin to improve performance. These designs do, however, increase the cost. The purchased round pin must be modified *and* carried as a separate part in a company's inventory. Depending upon the size of the company using the part, the administrative costs of carrying an extra part can be significantly greater than the costs associated with creating the modified pin. The engineer must therefore make sure that the gain in performance is worth the additional cost of creating a new part.

**Table 24-1** Alignment pins per ANSI B18.8.2-1978, R1989

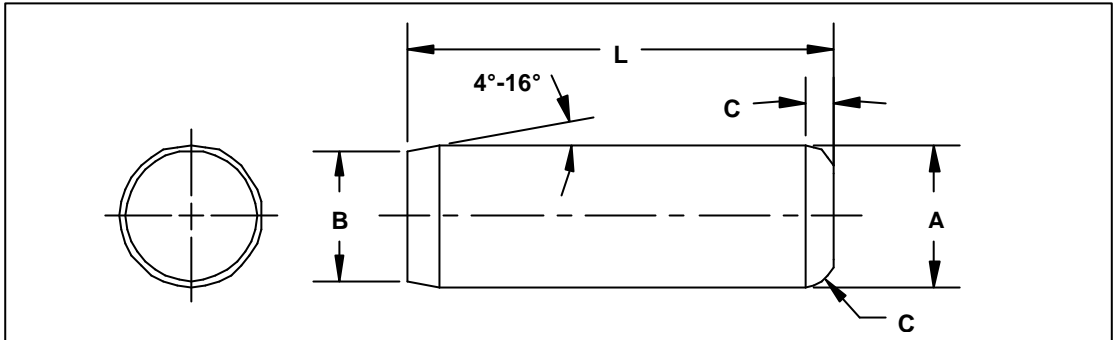

Nominal Size or Nominal Pin Diameter		Pin Diameter, A		Point Diameter, B		Crown Height or Radius, C		Common Lengths	Double Shear Load, Min, lbf for Carbon or Alloy Steel
		Nom (PPPP)	Tol	Nom	Tol	Nom	Tol		
1/16	.0625	.0627	±.0001	.053	.005	.014	.006	$\frac{3}{16} - \frac{3}{4}$	800
3/32	.0938	.094		.084		.0215	.0095	$\frac{3}{16} - 1$	1800
1/8	.1250	.1252		.115		.0285	.0125	$\frac{3}{8} - 2$	3200
3/16	.1875	.1877		.175		.0425	.0195	$\frac{1}{2} - 2$	7200
1/4	.2500	.2502		.235		.057	.026	$\frac{1}{2} - 2\frac{1}{2}$	12800
5/16	.3125	.3127		.296	.006	.0715	.0325	$\frac{1}{2} - 2\frac{1}{2}$	20000
3/8	.3750	.3752		.358	.008	.086	.039	$\frac{1}{2} - 3$	28700
7/16	.4375	.4377		.417		.1005	.0455	$\frac{7}{8} - 3$	39100
1/2	.5000	.5002		.479		.115	.052	$\frac{3}{4} - 4$	51000
5/8	.6250	.6252		.603		.143	.065	$1\frac{1}{4} - 5$	79800
3/4	.7500	.7502		.725	.010	.172	.078	$1\frac{1}{2} - 6$	114000
7/8	.8750	.8752		.850		.201	.092	2 - 6	156000
1	1.0000	1.0002		.970		.229	.104	2 - 6	204000

Another factor that may increase cost (if not performed properly) is pin installation. Modified pins must be aligned correctly to provide a benefit. Proper installation means having the center of the cutaway side(s) in line with the plane passing through the centers of the two pins. If the pins are installed correctly, the sides that are cut away provide additional clearance in one direction that can accommodate the variation in the distance between the pin and hole centers. This additional allowance allows the nominal size of the clearance holes to be reduced, thus reducing the translation and rotation errors through the interface.

The pins' improvement diminishes as the installation angle varies. Since pin installation is a manual operation, all analyses for these types of pins assume that the pin is installed 10° from the ideal installation angle.

Two configurations for the modified pin will be discussed—a diamond pin and a parallel-flats pin. Fig. 24-2 shows the typical cross-section of each pin. Both of them are fabricated by modifying the pins from Table 24-1—usually by grinding the flats.

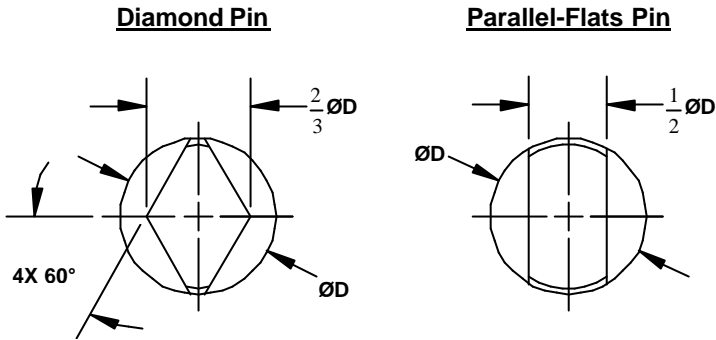

**Figure 24-2** Two common cross-sections for modified pins

## 24.6 Tolerance Allocation Methods—Worst Case vs. Statistical

As mentioned in previous chapters, there are many ways to analyze (or allocate) the effect of tolerances in an assembly. The most common and simple method is to assume that each dimension of interest is at its acceptable extreme and to analyze the combined effects of these “worst-case” dimensions. This methodology is very conservative, however, because the probability of all dimensions being at their limit simultaneously is extremely small.

An approach that better estimates the performance of the parts is to assume the dimensions are statistically distributed from part to part. The analysis involves assuming a distribution, usually normal, for each of the dimensions and determining the combined effects of the individual distributions on the assembly performance specifications. All of the statistical tolerances in this section have Six Sigma producibility (based on the process capabilities in section 24.7), and all of the statistical performance numbers have Six Sigma performance. In other words, 3.4 out of every million parts will have features within the indicated tolerances, and the same percentage of assemblies will fit and will meet the translation and rotation performance listed. (See Chapters 10 and 11 for further discussion of Six Sigma performance.)

Tables 24-4, 24-6, 24-8, 24-10, and 24-12 use the  $\langle \text{ST} \rangle$  symbol for all tolerances that result from statistical allocations. The engineer may want to use the following note on drawings containing the  $\langle \text{ST} \rangle$  symbol:

- Tolerances identified statistically  $\langle \text{ST} \rangle$  shall be produced by a process with a minimum Cpk of 1.5.

If the anticipated manufacturing facilities do not have methods to implement statistical tolerances, the engineer may opt to remove the  $\langle \text{ST} \rangle$  symbol. Without the symbol, though, the engineer assumes the responsibility of the design not performing as expected. (Refer to Chapter 11 for further discussions regarding the  $\langle \text{ST} \rangle$  symbol.)

## 24.7 Processes and Capabilities

This section will evaluate the differences between three different methods of generating the holes for alignment pins. These processes are:

- Drilling and reaming the alignment holes with the aid of drill bushings.
- Boring the holes on a numerically controlled (N/C) mill.
- Boring the holes on a Jig Bore.

Though there are other methods of generating holes, these are the more common ones with readily available capability information. The principles developed in this chapter can be extended to other manufacturing processes.

In the absence of general quantitative information about the capabilities of various machining processes, we must estimate an average capability. Though few sources provide true statistical information regarding these processes, we can make some assumptions based on recommended tolerances and historical quality levels. One such source of information is Bralla's *Handbook of Product Design for Manufacturing* (Reference 1). In it, the author provides many recommended tolerances for a range of manufacturing processes.

First, we will assume that the variation of the processes included in this section is normally distributed. Since historical estimates of acceptable producibility have been based on tolerances at three standard deviations from the mean, we will make this same assumption about the recommended manufacturing tolerances in Bralla's handbook. However, as discussed previously, Six Sigma analyses typically use short-term standard deviations, but these tolerances are more likely to be based on long-term effects. Therefore, it is reasonable to assume these tolerances represent four sigma, short-term capabilities. Table 24-2 presents the standard deviations used for all analyses in this section.

**Table 24-2** Standard deviations for common manufacturing processes (inches)

		Process		
		Drill and Ream with Bushings	N/C Boring	Jig Bore
<b>Hole Diameter</b>		.00025	.00025	.00013
<b>Hole/Pin Perpendicularity</b>		.00016	.00013	.00006
<b>± Distance From Target Position</b>	<b>From Part Surface</b>	.00250	.00200	.00100
	<b>From Another Hole</b>	.00063	.00050	.00025

An additional assumption concerning the perpendicularity of a hole relative to the surface into which it is placed is necessary for these analyses. Because Bralla doesn't include a standard deviation for perpendicularity, we will assume that the variation due to perpendicularity error is one-fourth of the total variation of the true position of a hole relative to another hole.

## 24.8 Design Methodology

Fig. 24-3 shows a flowchart for the design process using alignment pins. The following paragraphs explain the steps in more detail:

1. Select a pin size from Table 24-1. The decision on which pin to use will be driven by the geometry and mass of the mating parts or subassemblies. The ability to assemble and align the mating components is not a function of pin size or length, so this decision should be made without regard to these parameters. Keep in mind that for alignment purposes the pin need only protrude above the mating surface far enough to engage the clearance holes completely. Any additional length will only make assembly more difficult.
2. Once you have chosen the pin diameters, determine the maximum distance between all sets of pins. The least expensive design alternative that an engineer can choose to have the most significant improvement on the alignment performance of pinned interfaces is to move the pins as far apart as possible. Keep in mind that the walls around the pinholes, especially the interference holes, should have sufficient thickness to hold the pin and prevent part deformation, as this will affect alignment.

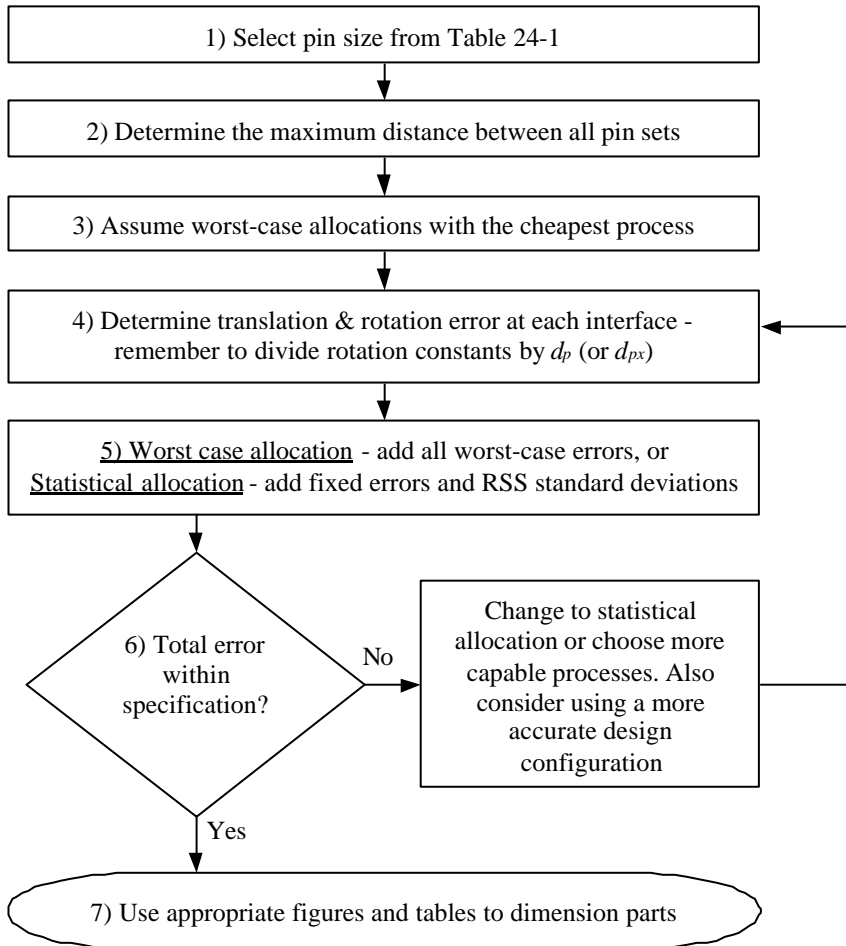

**Figure 24-3** Design process for using alignment data

3. Start with worst-case tolerance allocation with the least expensive process – usually drilling and reaming with the aid of drill bushings.<sup>1</sup>
4. Determine the translation and rotation errors at each interface from the tables in this section. There are a few important things to remember:
  - Most assembly stackups will have one Type I error and an additional Type II error for each part beyond two.
  - The rotation constants must be divided by  $d_p$  ( $d_{px}$  for two pins with one hole and edge contact) to determine the angular error occurring at the interface.
5. If performing a worst-case allocation, add all of the translation errors and rotation errors for each interface to determine the total errors occurring through the assembly. Also add to this the translation and rotation errors of the features of interest with respect to their datum reference frames. For example,

<sup>1</sup> There may be cases where drilling/reaming is not the least expensive method. If relatively few parts will be made over the life of the project or if drill fixtures are overly expensive, N/C milling may be a cheaper alternative. Communication with the manufacturing shops is essential in order to make wise tradeoffs between cost and function.

if performing an analysis on the slots in the design shown in Fig. 24-1, we would need to include the variations of the two slots relative to their respective DRFs of parts 1 and 2.

If performing a statistical allocation, the translation and rotation at each interface is comprised of two components – the fixed error associated with the nominal clearance between the hole and the pins and the standard deviation resulting from variation in the hole diameters. For statistical evaluation, the engineer should add each of the fixed error terms and then apply the assembly standard deviation to determine assembly performance. The assembly standard deviation is the root of the sum of the squares (RSS) of the standard deviations at each interface, as shown in the following equation:

$$s_{assy} = \sqrt{s_1^2 + s_2^2 + \dots + s_n^2}$$

Once you determine the assembly standard deviation, multiply it by six and add it to the fixed portion of the assembly variation to determine the Six Sigma translations and rotations for the assembly.

- Now compare the predicted performance numbers with the specifications. If the predictions meet or exceed the requirements, continue to Step 7. If the rotation performance is unacceptable, you must select either another allocation methodology, another manufacturing process, or type of design at the interfaces. If performing a worst-case analysis, change to a statistical allocation with the same manufacturing processes and go back to Step 4. If performing a statistical allocation, select a more capable process with a worst-case allocation and go back to Step 4. Finally, you can always select a more precise design configuration and go back to Step 4. The point of this iterative process is to start with the least expensive of all options and only add additional cost to gain performance as necessary.

If the rotation performance is acceptable but the translation is not, an additional option to reduce the translation error is to use two different clearance hole diameters. This method can only be applied to interfaces using two holes. If the engineer reduces the first clearance hole nominal diameter (the one for the round pin in interfaces with diamond or parallel-flats pins) and increases the second by the same amount, translation error decreases by one-half of the amount the hole diameter is reduced.

For worst-case allocations, the lower tolerances (tolerance in the negative direction) also have to change by the same amount as the nominal diameter. For example, if you decrease the first hole nominal diameter by .001, you must also:

- Increase the second hole nominal diameter by .001.
- Decrease the lower tolerance of the first hole by .001 (i.e., -.008 to -.007).
- Increase the lower tolerance of the second hole by .001 (i.e., -.008 to -.009).

For statistical allocations, the tolerances should not change. However, the engineer may wish to add an additional feature control frame controlling the perpendicularity of the first clearance hole relative to the mating surface as shown in statistical Callout B for the configuration with the slot. See Fig. 24-9 and Table 24-6.

Regardless of the tolerance allocation methodology, the smaller hole should never be smaller than the clearance holes specified for the configurations involving a slot or edge contact. The parts will still fit together and have the same rotational error as before the modification. Keep in mind, however, that the center of rotation will no longer be the midpoint between the two pins, but will move toward the smaller pinhole interface in proportion to the amount of the hole diameter reduction.

- Upon determining a combination of design configurations, manufacturing processes, and allocation methods that meet the specifications, use the figures and tables to apply geometric tolerances to your drawings. The nominal clearance hole diameter is found by adding the constant in the GD&T tables to the pin diameter being used. This is represented in the tables as  $\{.PPPP + constant\}$ , where *constant* represents the nominal clearance between the hole and the pin. (See Tables 24-4, 24-6, 24-8, 24-10, and 24-12.)

## 24-10 Chapter Twenty-four

All figures and most of the callouts in the tables assume Type I interfaces. For Type II interfaces, add the additional callout shown in the tables between the hole/pin diameter specification and the feature control frame(s) beneath it.

For example, if dimensioning a clearance hole that is located with respect to a set of pins on a part in a Type II two pin with one hole and edge contact interface, you should use the following callout:

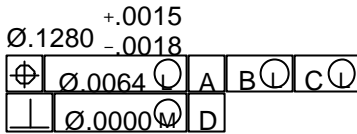

In this case, the pins used in the DRF for the part are datums B and C. The clearance hole is for a Ø.1252 pin in the mating part. The part that engages this hole mates against a surface defined as datum D. The first feature control frame controls the position of the clearance holes with respect to the DRF of the part. The second one controls the perpendicularity of the hole to the mating surface.

All other features of the parts where alignment is a concern should be dimensioned to the pin/hole DRF.

## 24.9 Proper Use of Material Modifiers

Because of the ability to inspect parts with gages, manufacturing personnel typically recommend using the maximum material condition (MMC) modifier on as many features of size as possible. While the MMC modifier makes sense with regard to the fit of the parts, its use can allow the other performance specifications dependent on the feature to have more error than originally anticipated. For example, if clearance holes are sized to fit, then adding the MMC modifier will allow more variation than explicitly allowed in the tolerances but will not adversely affect the ability to mate the parts. If the holes are dimensioned to another set of alignment features, the addition of the MMC modifier does increase the permissible translational and rotational errors throughout the assembly.

The problems can be avoided by using the following rules regarding material modifiers in the design of pinned interfaces:

- For statistical tolerance allocation, use only regardless of feature size (RFS) for the alignment features.
- For worst-case tolerance allocation, when the alignment holes or pins are used as the datum reference frame for the rest of the critical features on the parts, use the MMC modifier for the positional tolerance with respect to other noncritical features and with respect to each other. All critical features will be positioned with respect to the alignment pins or holes at LMC.
- Use either the RFS or LMC modifier for all other critical features of the parts. This not only includes the modifier for the positional tolerance but also applies to any datums of size referred to in the feature control frame.

All figures in this section showing recommended tolerances follow these three rules.

One other important topic involving the MMC modifier is the concept of zero positional tolerance at MMC. All clearance holes with worst-case tolerance allocation (except for the configuration involving a diamond pin) use this tolerancing method. The principle behind the method is relatively simple. If the hole is positioned perfectly, then we can allow its size to be as small as the outer boundary of the pin. However, as the hole diameter gets larger, it can also move and still be able to fit over the mating pin. If we were to use any number greater than zero in the position feature control frame, then the hole diameter would never be able to be as small as what is permitted when the hole is perfectly placed. Using zero position at MMC

therefore maximizes design efficiency by allowing the engineer to be able to use the smallest possible nominal hole diameter that still fits.

The unequal bilateral tolerance for the clearance holes using MMC represents the ideal manufacturing target for optimum producibility. In other words, given the assumed standard deviations in Table 24-2, the predicted defect rate below the lower tolerances is the same as the predicted defect rate above the upper tolerance. The sum of the two defect rates is 3.4 defects per million over the long term. The explanation of the defect calculation is beyond the scope of this chapter. What is important is that the nominal value should be the target for the manufacturing facilities. Many shops will not recognize this fact, so the engineer may wish to include a note on the drawing stating that the optimal manufacturing targets are provided by the nominal values for all dimensions.

Note that material modifiers are applicable only for worst-case methods. Statistical tolerance allocation for fit does not benefit, and may in fact be adversely affected by the use of material modifiers.

## 24.10 Temperature Considerations

The analysis of fit used to size the clearance holes is based upon assembly at 68° F.<sup>2</sup> If the parts are made from different materials and are to be assembled at temperatures other than 68° F, then the nominal size of the clearance holes should be increased to account for differences in expansion of the two parts. The additional allowance is given by the following equation:

$$D_h = d_p \cdot |D_T| \cdot |cte_1 - cte_2|$$

where  $D_h$  is the amount to increase each hole diameter,  $d_p$  is the distance between the pins,  $D_T$  is the difference between 68° F and the temperature at which the parts must assemble, and  $cte_1$  and  $cte_2$  are the coefficients of thermal expansion for the two mating parts. The effects of the differences in expansion of the pins and the holes do not contribute significantly and are not included in the above equation.

Increasing the nominal hole size for temperature effects will increase the alignment error between the parts if they are assembled at 68° F. The increase in translation is half of  $D_h$  calculated above and should be added to the translation errors in Tables 24-3, 24-9, and 24-11. Because rotation is a function of  $1/d_p$  and the holes are increased by a factor of  $d_p$ , the additional rotation is a constant added to the original rotation. The equation for rotation therefore becomes:

$$a_T = \frac{\text{constant}}{d_{pins}} + D_T \cdot |cte_1 - cte_2|$$

This equation should be used only when the clearance hole has been increased due to a requirement that the parts assemble at a range of temperatures and the parts are made of different materials.

## 24.11 Two Round Pins with Two Holes

This method uses two round pins and two clearance holes. The advantage of this method over most of the others is that this configuration requires less machining and uses no unmodified pins. This method does, however, require the largest clearance holes. As a result, performance is worse than all the other methods. Since this method is one of the cheapest (except for two round pins with one hole and edge contact) and most straightforward, the engineer should try this configuration first before proceeding to one of the others.

---

<sup>2</sup>per ASME Y14.5M-1994, Paragraph 1.4(k).

24.11.1 Fit

The following is the general equation determining whether or not the parts will assemble:

$$c = \frac{1}{2}(\varnothing_{h1} + \varnothing_{h2} - \varnothing_{p1} - \varnothing_{p2}) - |d_h - d_p| \geq .0001 \tag{24.2}$$

Fig. 24-4 shows the variables of Eq. (24.2) graphically. Though Eq. (24.2) is useful for worst case analysis, it cannot be solved statistically using partial differentiation. It can, however, be modified to examine the condition of fit statistically by removing the absolute value, as shown in the following equation:

$$c = \frac{1}{2}(\varnothing_{h1} + \varnothing_{h2} - \varnothing_{p1} - \varnothing_{p2}) - (d_h - d_p) \tag{24.3}$$

The condition of fit using Eq. (24.3) becomes:

$$.0001 \leq c \leq 2 \cdot c_{nom} - .0001$$

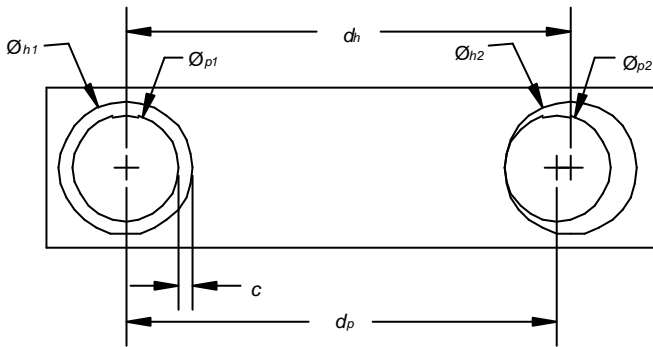

Figure 24-4 Variables contributing to fit of two round pins with two holes

24.11.2 Rotation Errors

The following equation gives the permissible rotation between the two parts:

$$a = \cos^{-1} \left[ \frac{d_h^2 + d_p^2 - \left( \frac{\varnothing_{h1} + \varnothing_{h2} - \varnothing_{p1} - \varnothing_{p2}}{2} \right)^2}{2 \cdot d_h \cdot d_p} \right]$$

Fig. 24-5 presents these variables graphically. Though Eq. (24.4) was used in determining the constants in Table 24-3, it does not resemble Eq. (24.1). However, Eq. (24.4) may be simplified. If we assume  $d_h = d_p$ ,  $\varnothing_{h2} = \varnothing_{h1}$ ,  $\varnothing_{p2} = \varnothing_{p1}$ ,  $\sin(a) \gg a$  (for small angles), and  $(\varnothing_h - \varnothing_p)^2 \gg 0$  when compared to  $4 \times d_p$ , then we can simplify Eq. (24.4) to:

$$a = \frac{(\varnothing_h - \varnothing_p)}{d_p} \tag{24.5}$$

The approximations made during this simplification are trivial and conservative (i.e., they result in rotations that are slightly larger than would be calculated without making these approximations). The simplified form of Eq. (24.5) is worth the slight additional error predicted.

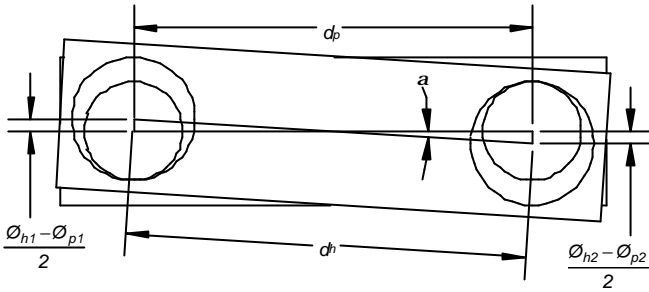

**Figure 24-5** Variables contributing to rotation caused by two round pins with two holes

### 24.11.3 Translation Errors

The maximum translation between two parts can be found from the following equation:

$$d = \frac{l}{2} \min (\varnothing_{h1} - \varnothing_{p1}, \varnothing_{h2} - \varnothing_{p2})$$

Because of the min function, it is difficult to analyze this equation statistically unless one uses simulation techniques. We therefore assume that the translation will be entirely controlled by the clearance at just one pin — the one with the smallest clearance. This results in slightly conservative performance limits.

### 24.11.4 Performance Constants

Table 24-3 includes the performance constants for all design options for two round pins with two holes. Remember to divide the rotation constants by  $d_p$  to determine the rotation through the interface.

**Table 24-3** Performance constants for two round pins with two holes

			Worst-Case	Statistical	
			Max Error	Fixed Error	Standard Deviation
Type I	Drill & Ream	Translation (inches)	.0052	.0028	.000125
		Rotation (inch•radians)	.0103	.0057	.0001768
	N/C Mill	Translation (inches)	.0043	.0023	.000125
		Rotation (inch•radians)	.0086	.0047	.0001768
	Jig Bore	Translation (inches)	.0023	.0012	.000065
		Rotation (inch•radians)	.0046	.0025	.0000884
Type II	Drill & Ream	Translation (inches)	.0092	.0028	.0006423
		Rotation (inch•radians)	.0184	.0057	.0009083
	N/C Mill	Translation (inches)	.0075	.0023	.0005154
		Rotation (inch•radians)	.0150	.0047	.0007289
	Jig Bore	Translation (inches)	.0039	.0012	.0002583
		Rotation (inch•radians)	.0078	.0025	.0003644

### 24.11.5 Dimensioning Methodology

Fig. 24-6 and Table 24-4 present the recommended dimensioning methods.

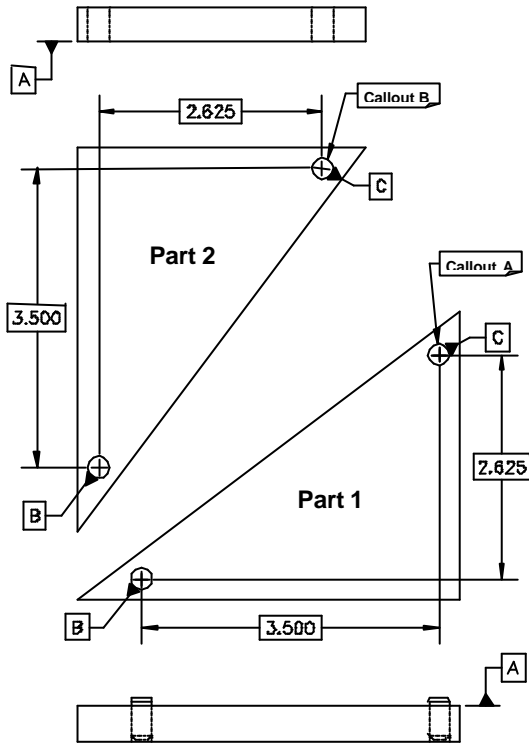

**Figure 24-6** Dimensioning methodology for two round pins with two holes (only Type I shown)

### 24.12 Round Pins with a Hole and a Slot

This configuration is very similar to two round pins with two holes except that one of the holes is elongated, creating a short slot. The benefit of elongating one hole is that it eliminates the errors in the distance between the pin centers and the distance between the hole centers from affecting the fit of the two parts. Therefore, the slot need only be long enough to accommodate the positional variation of the pins and the positional variation of the clearance features to one another. The slot is so short, in fact, that someone looking at the part would probably not be able to discern which feature was the hole and which feature was the slot.

Due to the critical tolerances on the width of the slot, the manufacturing shop should use multiple passes with a boring bar rather than profiling the slot with a side-mill cutter. Ideally, the first finish-boring pass will be at the center of the slot, and consecutive passes will be made on both sides to form the slot. This manufacturing method prohibits the use of a reamer, so this section only considers N/C milling and Jig Bore processes.

#### 24.12.1 Fit

Because this design configuration allows the distance between the pins and the distance between the hole and the slot to vary without affecting fit, the engineer need only be concerned with the size of the alignment features and the perpendicularity of the alignment features to the mating surfaces. If we size

Table 24-4 GD&T callouts for two round pins with two holes

Drill and Ream		N/C Bore	Jig Bore
<b>Callout A</b> 2X Ø.PPPP±.0001 Pins $\text{⌀} \begin{array}{ c } \hline \text{Ø.0041} \text{Ⓜ} \text{A} \\ \hline \end{array}$	2X Ø.PPPP±.0001 Pins $\text{⌀} \begin{array}{ c } \hline \text{Ø.0032} \text{Ⓜ} \text{A} \\ \hline \end{array}$	2X Ø.PPPP±.0001 Pins $\text{⌀} \begin{array}{ c } \hline \text{Ø.0016} \text{Ⓜ} \text{A} \\ \hline \end{array}$	2X Ø.PPPP±.0001 Pins $\text{⌀} \begin{array}{ c } \hline \text{Ø.0016} \text{Ⓜ} \text{A} \\ \hline \end{array}$
<b>Callout B</b> 2X Ø.{PPPP+.0087} <sup>+.0015</sup> <sub>-.0044</sub> $\text{⌀} \begin{array}{ c } \hline \text{Ø.0000} \text{Ⓜ} \text{A} \\ \hline \end{array}$	2X Ø.{PPPP+.0070} <sup>+.0015</sup> <sub>-.0036</sub> $\text{⌀} \begin{array}{ c } \hline \text{Ø.0000} \text{Ⓜ} \text{A} \\ \hline \end{array}$	2X Ø.{PPPP+.0037} <sup>+.0008</sup> <sub>-.0019</sub> $\text{⌀} \begin{array}{ c } \hline \text{Ø.0000} \text{Ⓜ} \text{A} \\ \hline \end{array}$	2X Ø.PPPP±.0001 Pins $\text{⌀} \begin{array}{ c } \hline \text{Ø.0032} \text{Ⓜ} \text{A} \\ \hline \end{array}$
<b>Additional Callout for Type II Interface</b> $\text{⌀} \begin{array}{ c } \hline \text{Ø.0081} \text{Ⓜ} \text{A} \\ \hline \end{array}$	$\text{⌀} \begin{array}{ c } \hline \text{Ø.0064} \text{Ⓜ} \text{A} \\ \hline \end{array}$	$\text{⌀} \begin{array}{ c } \hline \text{Ø.0032} \text{Ⓜ} \text{A} \\ \hline \end{array}$	$\text{⌀} \begin{array}{ c } \hline \text{Ø.0032} \text{Ⓜ} \text{A} \\ \hline \end{array}$
<b>Callout A</b> 2X Ø.PPPP±.0001 Pins $\text{⌀} \begin{array}{ c } \hline \text{Ø.0041} \text{Ⓜ} \text{A} \\ \hline \end{array}$	2X Ø.PPPP±.0001 Pins $\text{⌀} \begin{array}{ c } \hline \text{Ø.0032} \text{Ⓜ} \text{A} \\ \hline \end{array}$	2X Ø.PPPP±.0001 Pins $\text{⌀} \begin{array}{ c } \hline \text{Ø.0016} \text{Ⓜ} \text{A} \\ \hline \end{array}$	2X Ø.PPPP±.0001 Pins $\text{⌀} \begin{array}{ c } \hline \text{Ø.0016} \text{Ⓜ} \text{A} \\ \hline \end{array}$
<b>Callout B</b> 2X Ø.{PPPP+.0056} <sup>±.0015</sup> <sub>(ST)</sub> $\text{⌀} \begin{array}{ c } \hline \text{Ø.0041} \text{Ⓜ} \text{A} \\ \hline \end{array}$	2X Ø.{PPPP+.0046} <sup>±.0015</sup> <sub>(ST)</sub> $\text{⌀} \begin{array}{ c } \hline \text{Ø.0032} \text{Ⓜ} \text{A} \\ \hline \end{array}$	2X Ø.{PPPP+.0024} <sup>±.0008</sup> <sub>(ST)</sub> $\text{⌀} \begin{array}{ c } \hline \text{Ø.0016} \text{Ⓜ} \text{A} \\ \hline \end{array}$	2X Ø.PPPP±.0001 Pins $\text{⌀} \begin{array}{ c } \hline \text{Ø.0032} \text{Ⓜ} \text{A} \\ \hline \end{array}$
<b>Additional Callout for Type II Interface</b> $\text{⌀} \begin{array}{ c } \hline \text{Ø.0081} \text{Ⓜ} \text{A} \\ \hline \end{array}$	$\text{⌀} \begin{array}{ c } \hline \text{Ø.0064} \text{Ⓜ} \text{A} \\ \hline \end{array}$	$\text{⌀} \begin{array}{ c } \hline \text{Ø.0032} \text{Ⓜ} \text{A} \\ \hline \end{array}$	$\text{⌀} \begin{array}{ c } \hline \text{Ø.0032} \text{Ⓜ} \text{A} \\ \hline \end{array}$



### 24.12.3 Translation Errors

Because the interface between the pin and the hole has the minimum clearance in all directions, it will always control the translation between the mating parts. Furthermore, since only this interface is used to determine the fit of the parts, one cannot reduce the hole diameter and increase the slot dimensions in order to improve translation performance without adversely affecting fit. In other words, this design configuration is optimized for the best translation performance. Only by changing the manufacturing process can we improve performance while maintaining the same ability to assemble the parts.

The formula for determining the translation error is:

$$d = \frac{\varnothing_h - \varnothing_{p1}}{2}$$

### 24.12.4 Performance Constants

Table 24-5 includes the performance constants for all design options for two round pins with one hole and one slot. Remember to divide the rotation constants by  $d_p$  to determine the maximum allowable rotation through the interface.

**Table 24-5** Performance constants for two round pins with one hole and one slot

			Worst-Case	Statistical	
			Max Error	Fixed Error	Standard Deviation
<b>Type I</b>	N/C Mill	Translation (inches)	.00220	.00110	.000125
		Rotation (inch•radians)	.0023	.0022	.0001768
	Jig Bore	Translation (inches)	.00125	.0006	.000065
		Rotation (inch•radians)	.0013	.0012	.0000884
<b>Type II</b>	N/C Mill	Translation (inches)	.00540	.00110	.0005154
		Rotation (inch•radians)	.0087	.0022	.0007289
	Jig Bore	Translation (inches)	.00285	.0006	.0002583
		Rotation (inch•radians)	.0045	.0012	.0003644

### 24.12.5 Dimensioning Methodology

Fig. 24-9 and Table 24-6 present the recommended dimensioning methods for round pins with a hole and a slot. Datum C on the second part is two line targets at a basic distance from the center of the hole. This dimensioning scheme most closely represents how the part will function, though the pins may not contact the slot at exactly these targets.

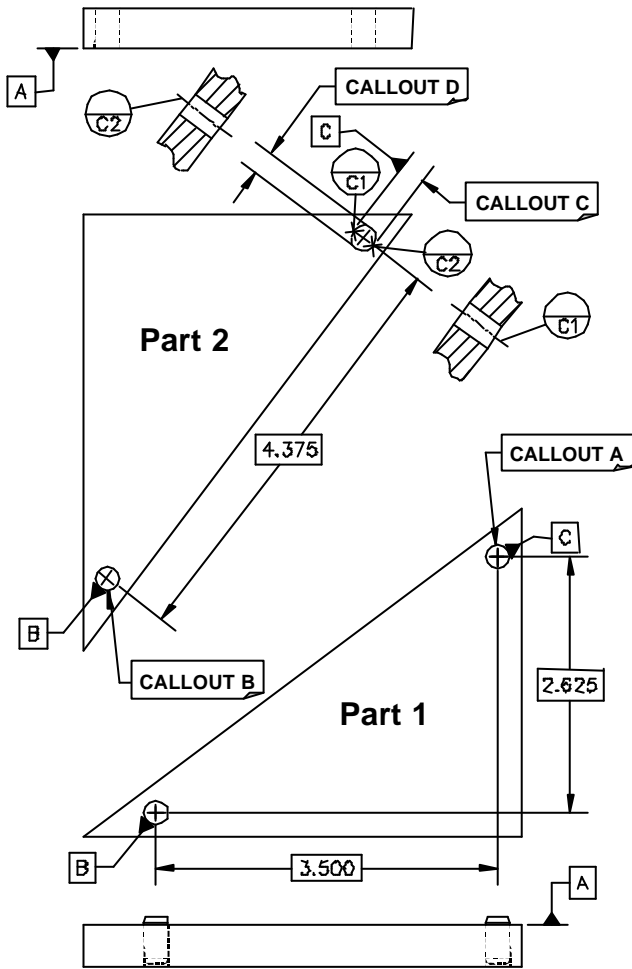

**Figure 24-9** Dimensioning methodology for two round pins with one hole and one slot (only Type I shown)

### 24.13 Round Pins with One Hole and Edge Contact

Another alignment methodology uses two pins to engage one hole and the side of the second part. Though this design is not used extensively, it provides the best performance at the least expense. Since the second feature used to engage the pin is not a feature of size, the clearance necessary to fit a feature of size over the second pin is eliminated and thus does not add to rotation error. Furthermore, since this design involves only one precision hole and no modified pins, it is the least expensive of all the configurations.

The primary drawback to this technique is that it requires the assembly operator to ensure that the second part is fully rotated and contacting the second pin on the side. Depending on the design, this can be verified quite easily through visual inspection. The additional cost associated with the added requirement during assembly is much less than the cost of the installation of the second pin.

**Table 24-6** GD&T callouts for two round pins with one hole and one slot

		N/C Bore	Jig Bore
<b>Worst Case</b>	<b>Callout A</b>	2X Ø.PPPP+0.001 Pins 	2X Ø.PPPP+0.001 Pins 
	<b>Callout B</b>	$\text{Ø}.\{\text{PPPP}+.0028\}_{-.0018}^{+.0015}$ 	$\text{Ø}.\{\text{PPPP}+.0016\}_{-.0010}^{+.0008}$ 
	<b>Callout C</b>	$\{\text{.PPPP}+.0028\}_{-.0018}^{+.0015}$ 	$\{\text{.PPPP}+.0028\}_{-.0010}^{+.0008}$ 
	<b>Callout D</b>	$\{\text{.PPPP}+.0108\} \pm .0050$ 	$\{\text{.PPPP}+.0080\} \pm .0050$ 
<b>Statistical</b>	<b>Additional Callout for Type II Interface</b>		
	<b>Callout A</b>	2X Ø.PPPP+0.001 Pins 	2X Ø.PPPP+0.001 Pins 
	<b>Callout B</b>	$\text{Ø}.\{\text{PPPP}+.0021\} \pm .0015$ 	$\text{Ø}.\{\text{PPPP}+.0011\} \pm .0008$ 
	<b>Callout C</b>	$\{\text{.PPPP}+.0021\} \pm .0015$ 	$\{\text{.PPPP}+.0011\} \pm .0008$ 
	<b>Callout D</b>	$\{\text{.PPPP}+.0095\} \pm .0050$ 	$\{\text{.PPPP}+.0074\} \pm .0050$ 
<b>Additional Callout for Type II Interface</b>			

**24.13.1 Fit**

Because only the first hole and pin are features of size, the fit for this configuration is exactly like the criteria for fit of the hole and slot given in Eq. (24.6).

24.13.2 Rotation Errors

The tilt resulting from this type of interface is obtained from the following equation:

$$a = -2 \tan^{-1} \left[ \frac{d_{px} - \sqrt{d_{px}^2 + \left[ d_{py} + \left( \frac{\phi_{h1} - \phi_{p1}}{2} \right) \right]^2} - \left( d_e + \frac{\phi_{p2}}{2} \right)^2}{d_{py} + d_e + \frac{\phi_{h1} - \phi_{p1}}{2} + \frac{\phi_{p2}}{2}} \right]$$

Fig. 24-10 presents these variables graphically.

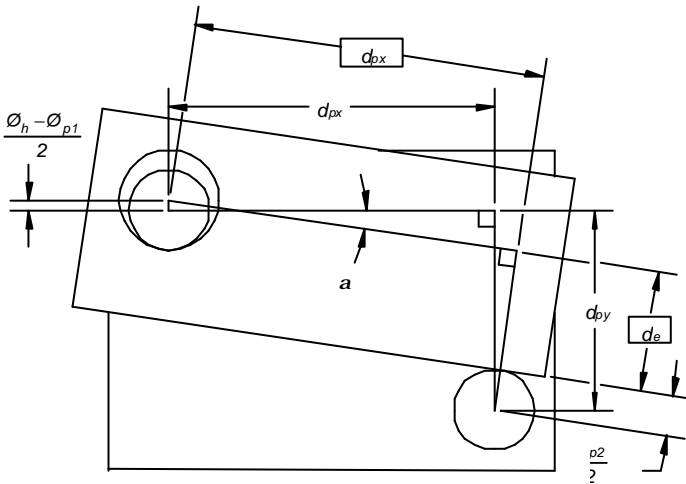

Figure 24-10 Variables contributing to rotation caused by two pins with hole and edge contact

24.13.3 Translation errors

The translation errors of this configuration are identical to those for the design involving two pins with one hole and one slot. (Refer to section 24.12.3.)

24.13.4 Performance Constants

Table 24-7 includes the performance constants for all design options for two round pins with one hole and edge contact. In this case, only increasing  $d_{px}$  improves the tilt. Remember to divide the rotation constants by  $d_{px}$  to determine the rotation allowed by the interface.

24.13.5 Dimensioning Methodology

Fig. 24-11 and Table 24-8 present the recommended dimensioning methods for two pins with one hole and edge contact. Datum C on the part 2 is a line target contacting the edge at the approximate location of the pin on part 1. It is found by placing two pins in a gage at the basic dimensions indicated on the drawing. This method of establishing the datum eliminates the distance indicated as basic in Fig. 24-11 from becoming contributors to the rotation error between the parts. Similarly, since the second pin is the datum for part 2, the variation in  $d_y$  also does not contribute to the rotation variation.

Table 24-7 Performance constants for two round pins with one hole and edge contact

			Worst-Case	Statistical	
			Max Error	Fixed Error	Standard Deviation
Type I	Drill and Ream	Translation (inches)	.00235	.0016	.000125
		Rotation (inch•radians)	.0024	.0012	.0001249
	N/C Mill	Translation (inches)	.0022	.00145	.000125
		Rotation (inch•radians)	.0023	.0012	.0001249
Jig Bore	Translation (inches)	.00125	.00085	.000065	
	Rotation (inch•radians)	.0013	.0007	.0000625	
Type II	Drill and Ream	Translation (inches)	.0064	.0016	.00064228
		Rotation (inch•radians)	.0105	.0012	.0008997
	N/C Mill	Translation (inches)	.0054	.00145	.0005154
		Rotation (inch•radians)	.0087	.0012	.0007181
	Jig Bore	Translation (inches)	.00285	.00085	.0002583
		Rotation (inch•radians)	.0045	.0007	.0003590

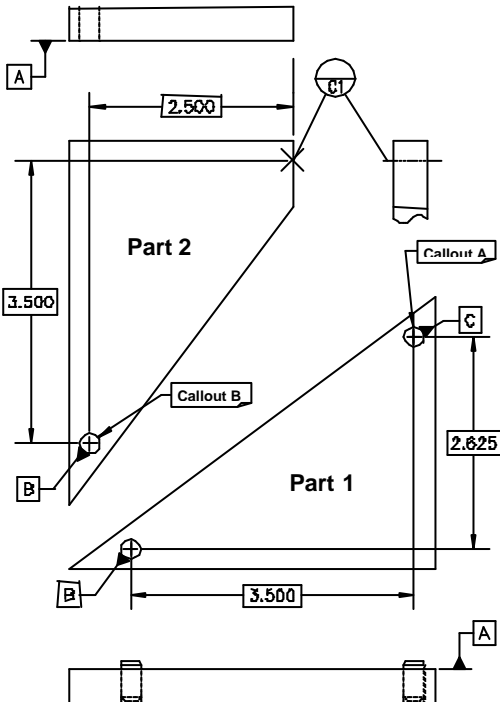

Figure 24-11 Dimensioning methodology for two round pins with one hole and edge contact (only Type I shown)

Table 24-8 GD&T callouts for two round pins with one hole and edge contact

	Drill and Ream	N/C Bore	Jig Bore
Callout A	2X Ø.PPPP±.0001 Pins $\text{Ø} \begin{array}{ c } \hline \text{Ø}.0041 \text{ (M)}   \text{A} \\ \hline \end{array}$	2X Ø.PPPP±.0001 Pins $\text{Ø} \begin{array}{ c } \hline \text{Ø}.0032 \text{ (M)}   \text{A} \\ \hline \end{array}$	2X Ø.PPPP±.0001 Pins $\text{Ø} \begin{array}{ c } \hline \text{Ø}.0016 \text{ (M)}   \text{A} \\ \hline \end{array}$
	Callout B	$\text{Ø} \{ \text{PPPP} + .0031 \} \begin{array}{ c } \hline \text{Ø}.0000 \text{ (M)}   \text{A} \\ \hline \end{array}$ $\text{Ø} \{ \text{PPPP} + .0028 \} \begin{array}{ c } \hline \text{Ø}.0000 \text{ (M)}   \text{A} \\ \hline \end{array}$ $\text{Ø} \{ \text{PPPP} + .0015 \} \begin{array}{ c } \hline \text{Ø}.0000 \text{ (M)}   \text{A} \\ \hline \end{array}$ $\text{Ø} \{ \text{PPPP} + .0016 \} \begin{array}{ c } \hline \text{Ø}.0000 \text{ (M)}   \text{A} \\ \hline \end{array}$	$\text{Ø} \{ \text{PPPP} + .0022 \} \begin{array}{ c } \hline \text{Ø}.0004 \text{ (ST)}   \text{A} \\ \hline \end{array}$ $\text{Ø} \{ \text{PPPP} + .0015 \} \begin{array}{ c } \hline \text{Ø}.0008 \text{ (ST)}   \text{A} \\ \hline \end{array}$ $\text{Ø} \{ \text{PPPP} + .0021 \} \begin{array}{ c } \hline \text{Ø}.0015 \text{ (ST)}   \text{A} \\ \hline \end{array}$ $\text{Ø} \{ \text{PPPP} + .0011 \} \begin{array}{ c } \hline \text{Ø}.0008 \text{ (ST)}   \text{A} \\ \hline \end{array}$
Additional Callout for Type II Interface	$\text{Ø} \begin{array}{ c } \hline \text{Ø}.0081 \text{ (L)}   \text{A}   \text{B}   \text{C}   \text{D} \\ \hline \end{array}$	$\text{Ø} \begin{array}{ c } \hline \text{Ø}.0064 \text{ (L)}   \text{A}   \text{B}   \text{C}   \text{D} \\ \hline \end{array}$	$\text{Ø} \begin{array}{ c } \hline \text{Ø}.0032 \text{ (L)}   \text{A}   \text{B}   \text{C}   \text{D} \\ \hline \end{array}$
Callout A	2X Ø.PPPP±.0001 Pins $\text{Ø} \begin{array}{ c } \hline \text{Ø}.0041 \text{ (ST)}   \text{A} \\ \hline \end{array}$	2X Ø.PPPP±.0001 Pins $\text{Ø} \begin{array}{ c } \hline \text{Ø}.0032 \text{ (ST)}   \text{A} \\ \hline \end{array}$	2X Ø.PPPP±.0001 Pins $\text{Ø} \begin{array}{ c } \hline \text{Ø}.0016 \text{ (ST)}   \text{A} \\ \hline \end{array}$
	Callout B	$\text{Ø} \{ \text{PPPP} + .0022 \} \begin{array}{ c } \hline \text{Ø}.0010 \text{ (ST)}   \text{A} \\ \hline \end{array}$ $\text{Ø} \{ \text{PPPP} + .0015 \} \begin{array}{ c } \hline \text{Ø}.0015 \text{ (ST)}   \text{A} \\ \hline \end{array}$	$\text{Ø} \{ \text{PPPP} + .0021 \} \begin{array}{ c } \hline \text{Ø}.0015 \text{ (ST)}   \text{A} \\ \hline \end{array}$ $\text{Ø} \{ \text{PPPP} + .0011 \} \begin{array}{ c } \hline \text{Ø}.0008 \text{ (ST)}   \text{A} \\ \hline \end{array}$
Additional Callout for Type II Interface	$\text{Ø} \begin{array}{ c } \hline \text{Ø}.0081 \text{ (ST)}   \text{A}   \text{B}   \text{C} \\ \hline \end{array}$	$\text{Ø} \begin{array}{ c } \hline \text{Ø}.0064 \text{ (ST)}   \text{A}   \text{B}   \text{C} \\ \hline \end{array}$	$\text{Ø} \begin{array}{ c } \hline \text{Ø}.0032 \text{ (ST)}   \text{A}   \text{B}   \text{C} \\ \hline \end{array}$
<b>Worst Case</b>		<b>Statistical</b>	

### 24.14 One Diamond Pin and One Round Pin with Two Holes

This design configuration is very similar to two pins with two holes. The difference is the shape of the second pin. In this case, the flats on the second pin accommodate more variation in the distance between the pins and the distance between the holes. This enables us to decrease the nominal hole diameter, thus improving performance without affecting fit. Because the allowable location error gained from the pin is greater than with the parallel-flats pin, and because the diamond pin is stronger than the parallel-flats pin, this is the preferred method for designs using modified pins.

As was mentioned in section 24.9, this configuration does not benefit from zero position at MMC. In fact, if we were to use this tolerancing scheme, we would have to make the nominal hole diameter larger. The equation for fit is actually more sensitive to the diameter of the second hole than to the distance between the holes. As a result, zero position at MMC is not as efficient as the dimensioning methodology of Table 24-10.

#### 24.14.1 Fit

The equation for fit is:

$$c = \frac{1}{2}(\varnothing_{h1} - \varnothing_{p1}) - d_p + z \cdot \cos(\mathbf{b}) - d_h \cdot \cos \left\{ \tan^{-1} \left[ \frac{\sin(\mathbf{b})}{\cos(\mathbf{b}) + \frac{d_p}{z}} \right] \right\}$$

where

$$z = \frac{1}{2} \sqrt{\varnothing_{h2}^2 - \left\{ \varnothing_{p2}^2 \cdot \cos \left[ \frac{p}{6} + \cos^{-1} \left( \frac{2t}{\varnothing_{p2}^2} \right) \right] \right\}^2} - \frac{1}{2} \sqrt{\varnothing_{p2}^2 - \left\{ \varnothing_{p2}^2 \cdot \cos \left[ \frac{p}{6} + \cos^{-1} \left( \frac{2t}{\varnothing_{p2}^2} \right) \right] \right\}^2}$$

Fig. 24-12 provides a graphical representation of these variables.

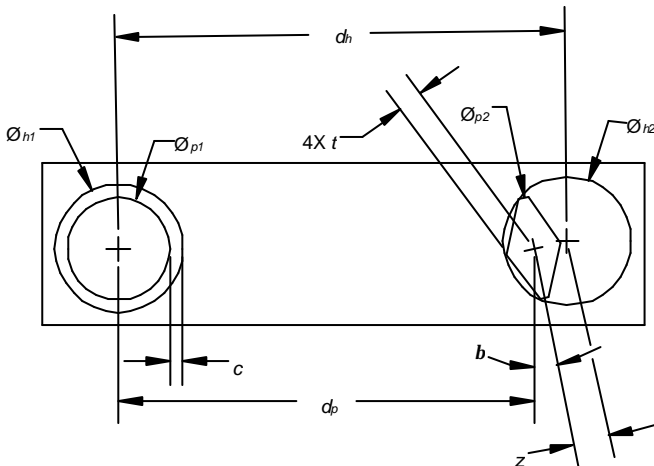

**Figure 24-12** Variables contributing to fit of one round pin and one diamond pin with two holes

### 24.14.2 Rotation and Translation Errors

Because the rotation is controlled by the cylindrical sections of both pins and the round pin will control translation, the formulas for rotation and translation errors are the same as for the two round pins with two round holes in sections 24.11.2 and 24.11.3.

### 24.14.3 Performance Constants

Table 24-9 includes the performance constants for all design options for one round pin and one diamond pin with two holes. Remember to divide the rotation constants by  $d_p$  to determine the allowable rotation at the interface.

**Table 24-9** Performance constants for one round pin and one diamond pin with two holes

			Worst-Case	Statistical	
			Max Error	Fixed Error	Standard Deviation
<b>Type I</b>	Drill and Ream	Translation (inches)	.00275	.00095	.0001250
		Rotation (inch•radians)	.005516	.0019	.0001768
	N/C Mill	Translation (inches)	.00245	.00085	.0001250
		Rotation (inch•radians)	.004916	.0017	.0001768
	Jig Bore	Translation (inches)	.00130	.0005	.0000650
		Rotation (inch•radians)	.002603	.0010	.0000884
<b>Type II</b>	Drill and Ream	Translation (inches)	.00685	.00095	.0006423
		Rotation (inch•radians)	.013616	.0019	.0009083
	N/C Mill	Translation (inches)	.00565	.00085	.0005154
		Rotation (inch•radians)	.0011316	.0017	.0007289
	Jig Bore	Translation (inches)	.00290	.0005	.0002583
		Rotation (inch•radians)	.005803	.0010	.0003644

### 24.14.4 Dimensioning Methodology

Table 24-10 presents the recommended dimensioning methods for one diamond pin and one round pin with two holes. Refer to Fig. 24-6 for the graphical portion of the callouts.

Table 24-10 GD&T callouts for one round pin and one diamond pin with two holes

		Drill and Ream	N/C Bore	Jig Bore
Worst Case	Callout A	2X Ø.PPPP±.0001 Pins $\text{⌀} \begin{array}{ c c c } \hline \text{⌀} & \text{0.0041} & \text{M} & \text{A} \\ \hline \end{array}$	2X Ø.PPPP±.0001 Pins $\text{⌀} \begin{array}{ c c c } \hline \text{⌀} & \text{0.0032} & \text{M} & \text{A} \\ \hline \end{array}$	2X Ø.PPPP±.0001 Pins $\text{⌀} \begin{array}{ c c c } \hline \text{⌀} & \text{0.0016} & \text{M} & \text{A} \\ \hline \end{array}$
	Callout B	2X Ø.{PPPP+.0039} ±.0015 $\text{⌀} \begin{array}{ c c } \hline \text{⌀} & \text{0.0041} & \text{A} \\ \hline \end{array}$	2X Ø.{PPPP+.0033} ±.0015 $\text{⌀} \begin{array}{ c c } \hline \text{⌀} & \text{0.0032} & \text{A} \\ \hline \end{array}$	2X Ø.{PPPP+.0017} ±.0008 $\text{⌀} \begin{array}{ c c } \hline \text{⌀} & \text{0.0016} & \text{A} \\ \hline \end{array}$
	Additional Callout for Type II Interface	$\text{⌀} \begin{array}{ c c c c c } \hline \text{⌀} & \text{0.0081} & \text{L} & \text{A} & \text{B} & \text{L} & \text{C} & \text{L} \\ \hline \end{array}$	$\text{⌀} \begin{array}{ c c c c c } \hline \text{⌀} & \text{0.0064} & \text{L} & \text{A} & \text{B} & \text{L} & \text{C} & \text{L} \\ \hline \end{array}$	$\text{⌀} \begin{array}{ c c c c c } \hline \text{⌀} & \text{0.0032} & \text{L} & \text{A} & \text{B} & \text{L} & \text{C} & \text{L} \\ \hline \end{array}$
Statistical	Callout A	2X Ø.PPPP±.0001 Pins $\text{⌀} \begin{array}{ c c c } \hline \text{⌀} & \text{0.0041} & \text{ST} & \text{A} \\ \hline \end{array}$	2X Ø.PPPP±.0001 Pins $\text{⌀} \begin{array}{ c c c } \hline \text{⌀} & \text{0.0032} & \text{ST} & \text{A} \\ \hline \end{array}$	2X Ø.PPPP±.0001 Pins $\text{⌀} \begin{array}{ c c c } \hline \text{⌀} & \text{0.0016} & \text{ST} & \text{A} \\ \hline \end{array}$
	Callout B	2X Ø.{PPPP+.0018} ±.0015 $\overline{\text{ST}}$ $\text{⌀} \begin{array}{ c c c } \hline \text{⌀} & \text{0.0041} & \overline{\text{ST}} & \text{A} \\ \hline \end{array}$	2X Ø.{PPPP+.0016} ±.0015 $\overline{\text{ST}}$ $\text{⌀} \begin{array}{ c c c } \hline \text{⌀} & \text{0.0032} & \overline{\text{ST}} & \text{A} \\ \hline \end{array}$	2X Ø.{PPPP+.0009} ±.0008 $\overline{\text{ST}}$ $\text{⌀} \begin{array}{ c c c } \hline \text{⌀} & \text{0.0016} & \overline{\text{ST}} & \text{A} \\ \hline \end{array}$
	Additional Callout for Type II Interface	$\text{⌀} \begin{array}{ c c c c } \hline \text{⌀} & \text{0.0081} & \overline{\text{ST}} & \text{A} & \text{B} & \text{C} \\ \hline \end{array}$	$\text{⌀} \begin{array}{ c c c c } \hline \text{⌀} & \text{0.0064} & \overline{\text{ST}} & \text{A} & \text{B} & \text{C} \\ \hline \end{array}$	$\text{⌀} \begin{array}{ c c c c } \hline \text{⌀} & \text{0.0032} & \overline{\text{ST}} & \text{A} & \text{B} & \text{C} \\ \hline \end{array}$

### 24.15 One Parallel-Flats Pin and One Round Pin with Two Holes

This is the least attractive of all the design configurations included in this section. The grinding of the second pin, though not quite as involved as with a diamond pin, still adds additional costs associated with the machining and storage of the special part. The modified pin is the weakest and is therefore subject to bending during installation.

Another disadvantage of the parallel-flats shape is that the intersection of the unmodified diameter and the flat section is a sharper corner than with the diamond shape. This can lead to increased damage from galling when the pin begins to engage the clearance hole of the mating part during assembly.

#### 24.15.1 Fit

Determination of fit for parts aligned using one round pin and one diamond pin is given by:

$$c = \frac{1}{2}(\varnothing_{h1} - \varnothing_{p1}) - d_p + z \cdot \cos(\mathbf{b}) - d_h \cdot \cos \left\{ \tan^{-1} \left[ \frac{\sin(\mathbf{b})}{\cos(\mathbf{b}) + \frac{d_p}{z}} \right] \right\}$$

where

$$z = \frac{1}{2} \sqrt{\varnothing_{h2}^2 - \left\{ \varnothing_{p2} \cdot \sin \left[ \cos^{-1} \left( \frac{2t}{\varnothing_{p2}} \right) \right] \right\}^2} - \frac{1}{2} \sqrt{\varnothing_{p2}^2 - \left\{ \varnothing_{p2} \cdot \sin \left[ \cos^{-1} \left( \frac{2t}{\varnothing_{p2}} \right) \right] \right\}^2}$$

Fig. 24-13 presents these variables graphically.

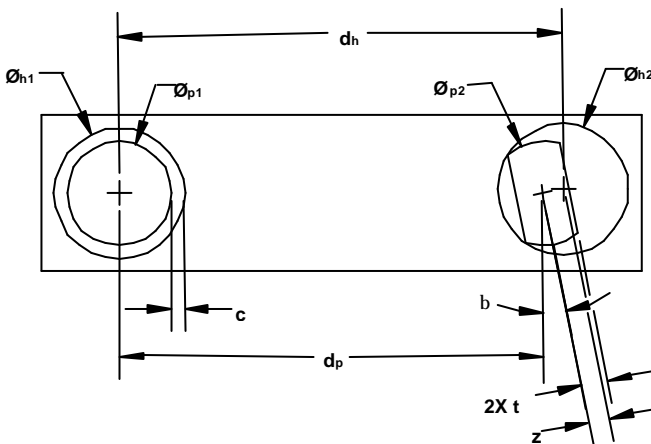

**Figure 24-13** Variables contributing to the fit of one pin and one parallel-flats pin with two holes

### 24.15.2 Rotation and Translation Errors

Because the rotation is controlled by the cylindrical sections of both pins, and the round pin will control translation, the formulas for rotation and translation errors are the same as for the two round pins with two round holes in sections 24.11.2 and 24.11.3.

### 24.15.3 Performance Constants

Table 24-11 includes the performance constants for all design options for one round pin and one parallel-flats pin with two holes. Remember to divide the rotation constants by  $d_p$  to determine the rotation through the interface.

**Table 24-11** Performance constants for one round pin and one parallel-flats pin with two holes

<i>Two Holes with One Parallel-Flats Pin and One Round Pin</i>			Worst-Case	Statistical	
			Max Error	Fixed Error	Standard Deviation
<b>Type I</b>	Drill and Ream	Translation (inches)	.00450	.00210	.0001250
		Rotation (inch•radians)	.009	.0042	.0001768
	N/C Mill	Translation (inches)	.00380	.00170	.0001250
		Rotation (inch•radians)	.0076	.0034	.0001768
	Jig Bore	Translation (inches)	.00205	.00095	.0000650
		Rotation (inch•radians)	.0041	.0019	.0000884
<b>Type II</b>	Drill and Ream	Translation (inches)	.00855	.00210	.0006423
		Rotation (inch•radians)	.0171	.0042	.0009083
	N/C Mill	Translation (inches)	.00510	.00170	.0005154
		Rotation (inch•radians)	.0140	.0034	.0007289
	Jig Bore	Translation (inches)	.00365	.00095	.0002583
		Rotation (inch•radians)	.0073	.0019	.0003644

24.15.4 Dimensioning Methodology

Table 24-12 presents the recommended dimensioning methods for two holes, one round pin, and one parallel flat pin. Refer to Fig. 24-6 in section 24.11.5 for the graphical portion of the callouts.

**Table 24-12** GD&T callouts for one round pin with one parallel-flats pin and two holes

	Drill and Ream	N/C Bore	Jig Bore
<b>Callout A</b>	2X Ø.PPPP±.0001 Pins $\begin{array}{ c } \hline \text{Ø} \text{.0041} \text{ (M)} \text{ A} \\ \hline \end{array}$	2X Ø.PPPP±.0001 Pins $\begin{array}{ c } \hline \text{Ø} \text{.0032} \text{ (M)} \text{ A} \\ \hline \end{array}$	2X Ø.PPPP±.0001 Pins $\begin{array}{ c } \hline \text{Ø} \text{.0016} \text{ (M)} \text{ A} \\ \hline \end{array}$
	<b>Callout B</b>	2X Ø.{PPPP+.0074} <sup>+0.0015</sup> <sub>-.0044</sub> $\begin{array}{ c } \hline \text{Ø} \text{.0000} \text{ (M)} \text{ A} \\ \hline \end{array}$	2X Ø.{PPPP+.0060} <sup>+0.0015</sup> <sub>-.0036</sub> $\begin{array}{ c } \hline \text{Ø} \text{.0000} \text{ (M)} \text{ A} \\ \hline \end{array}$
<b>Additional Callout for Type II Interface</b>	$\begin{array}{ c } \hline \text{Ø} \text{.0081} \text{ (L)} \text{ A} \text{ B} \text{ (L)} \text{ C} \text{ (L)} \\ \hline \end{array}$	$\begin{array}{ c } \hline \text{Ø} \text{.0064} \text{ (L)} \text{ A} \text{ B} \text{ (L)} \text{ C} \text{ (L)} \\ \hline \end{array}$	$\begin{array}{ c } \hline \text{Ø} \text{.0032} \text{ (L)} \text{ A} \text{ B} \text{ (L)} \text{ C} \text{ (L)} \\ \hline \end{array}$
<b>Callout A</b>	2X Ø.PPPP±.0001 Pins $\begin{array}{ c } \hline \text{Ø} \text{.0041} \text{ (ST)} \text{ A} \\ \hline \end{array}$	2X Ø.PPPP±.0001 Pins $\begin{array}{ c } \hline \text{Ø} \text{.0032} \text{ (ST)} \text{ A} \\ \hline \end{array}$	2X Ø.PPPP±.0001 Pins $\begin{array}{ c } \hline \text{Ø} \text{.0016} \text{ (ST)} \text{ A} \\ \hline \end{array}$
	<b>Callout B</b>	2X Ø.{PPPP+.0041} ±.0015 (ST) $\begin{array}{ c } \hline \text{Ø} \text{.0041} \text{ (ST)} \text{ A} \\ \hline \end{array}$	2X Ø.{PPPP+.0018} ±.0008 (ST) $\begin{array}{ c } \hline \text{Ø} \text{.0016} \text{ (ST)} \text{ A} \\ \hline \end{array}$
<b>Additional Callout for Type II Interface</b>	$\begin{array}{ c } \hline \text{Ø} \text{.0081} \text{ (ST)} \text{ A} \text{ B} \text{ C} \\ \hline \end{array}$	$\begin{array}{ c } \hline \text{Ø} \text{.0064} \text{ (ST)} \text{ A} \text{ B} \text{ C} \\ \hline \end{array}$	$\begin{array}{ c } \hline \text{Ø} \text{.0032} \text{ (ST)} \text{ A} \text{ B} \text{ C} \\ \hline \end{array}$
<b>Worst Case</b>		<b>Statistical</b>	

## 24.16 References

1. Bralla, James G. 1986. *Handbook of Product Design for Manufacturing: A Practical Guide to Low-Cost Production*. New York, NY: McGraw-Hill Book Company.
2. The American Society of Mechanical Engineers. 1995. *ASME B18.8.2-1978(R1989): Taper Pins, Dowel Pins, Straight Pins, Grooved Pins, and Spring Pins (Inch Series)*. New York, NY: The American Society of Mechanical Engineers.
3. The American Society of Mechanical Engineers. 1995. *ASME Y14.5M-1994, Dimensioning and Tolerancing*. New York, NY: The American Society of Mechanical Engineers.