

Gage Repeatability and Reproducibility (GR&R) Calculations

Gregory A. Hetland, Ph.D.
Hutchinson Technology Inc.
Hutchinson, Minnesota

Dr. Hetland is the manager of corporate standards and measurement sciences at Hutchinson Technology Inc. With more than 25 years of industrial experience, he is actively involved with national, international, and industrial standards research and development efforts in the areas of global tolerancing of mechanical parts and supporting metrology. Dr. Hetland's research has focused on "tolerancing optimization strategies and methods analysis in a sub-micrometer regime."

25.1 Introduction

This chapter shows examples of calculating capabilities for a gage repeatability and reproducibility (GR&R) study on geometric tolerances, and identifies ambiguities as well as limitations in these calculations. Additionally, it shows tremendous areas of opportunity for future research and development in GR&R calculations due to past and still-current limitations in the variables considered when making these calculations. This chapter will define conditions not being accounted for in the calculations, therefore limiting the measurement system's capabilities.

25.2 Standard GR&R Procedure

The following is a standard procedure used for calculating a GR&R that relates to geometric controls per ASME Y14.5M-1994. Initial analysis will focus on a positional tolerance in a nondiametral tolerance zone. Please note: A small sample size is used only out of convenience. Small sample sizes are strongly supported when needing a quick "snap-shot" of a capability. I do not, however, promote small sizes for in-depth analysis.

25-2 Chapter Twenty-five

- Given 10 parts measured twice under the same conditions
 - Same procedure
 - Same machine
 - Same person
- Resultant Values (R.V.) are to be shown in positional form (not just x or y displacement).
- Derive the range between runs for Part 1, Part 2, ... Part 10.
- Sum the ranges and divide by 10 to derive the R.
- Divide the R by a constant of 1.128, for sample/run size of 2 (rough estimate of sigma based on small sample size).
- Multiply $3 \times$ the estimate of sigma (3σ) and divide by the positional tolerance allowed in the feature control frame, then multiply $\times 100$. (This derived value will represent the percentage of tolerance used by the gage.)

The following data (Table 25-1) applies to the positional control of 0.2 mm, in relationship to datums A primary and B secondary at regardless of feature size (RFS) as shown in Fig. 25-1.

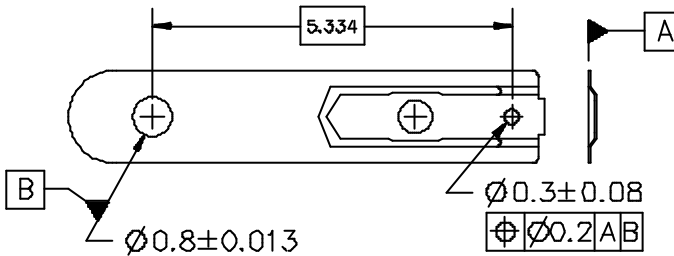

Figure 25-1 Sample drawing #1

Table 25-1 GR&R Analysis Matrix

Part #	Run #1 X displacement	$2\sqrt{\Delta X^2 + \Delta Y^2}$ R.V.#1	Run #2 X displacement	$2\sqrt{\Delta X^2 + \Delta Y^2}$ R.V.#2	Range Between RV#1 & RV#2
1	0.02	0.04	0.03	0.06	0.02
2	0.05	0.10	0.07	0.14	0.04
3	-0.03	0.06	-0.01	0.02	0.04
4	0.01	0.02	0.04	0.08	0.06
5	-0.04	0.08	-0.04	0.08	0.00
6	0.07	0.14	0.05	0.10	0.04
7	-0.06	0.12	-0.04	0.08	0.04
8	0.02	0.04	0.01	0.02	0.02
9	-0.09	0.18	-0.10	0.20	0.02
10	-0.05	0.10	-0.03	0.06	0.04

$$\bar{R} = 0.032$$

$$\sigma = 0.032/1.128 = 0.0284$$

$$3\sigma = 3 \times 0.0284 = 0.085$$

$$3\sigma / \text{Tol.} \times 100 = \% \text{ of tolerance}$$

$$0.085/0.2 \times 100 = 42.6 \%$$

Questions arise regarding these calculations and whether sigma should be multiplied by 3 or 6. Figs. 25-2 and 25-3 are examples of tolerance zone differences, comparing a linear +/-0.1 mm tolerance to a nondiametral position tolerance of 0.2 mm.

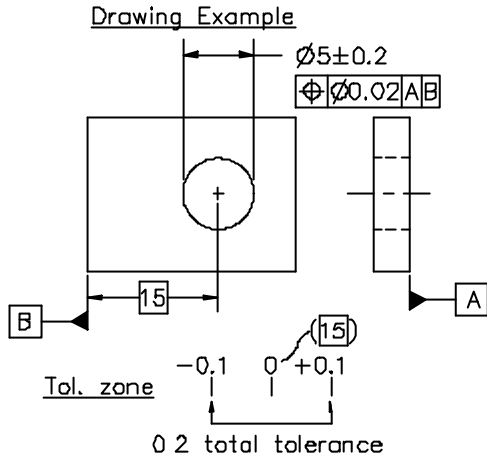
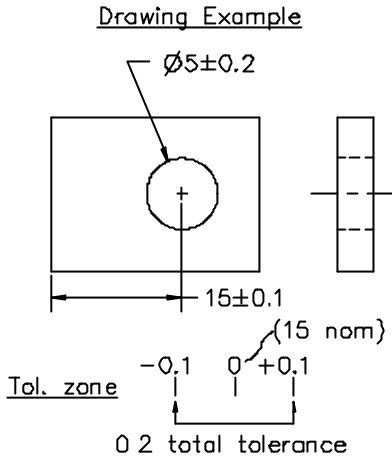

Measured Values

Part#	Run #1	Run #2	Range
1	0.02	0.03	0.01
2	0.05	0.07	0.02
3	-0.03	-0.01	0.02
4	0.01	0.04	0.03
5	-0.04	-0.04	0.00
6	0.07	0.05	0.02
7	-0.06	-0.04	0.02
8	0.02	0.01	0.01
9	-0.09	-0.10	0.01
10	-0.05	-0.03	0.02

$\bar{R} = \Sigma R/n = 0.16/10 = 0.016$

$\Delta = \bar{R}/d_2 = 0.016/1.128 = 0.0142$

$6\Delta = 6 \times 0.0142 = 0.085$

$6\Delta/\text{Tol.} \times 100 = \% \text{ of tolerance}$

$0.085/0.2 \times 100 = 42.6\%$

Resultant Values derived from measured values in example to the left

Part#	Run #1	Run #2	Range
1	0.04	0.06	0.02
2	0.10	0.14	0.04
3	0.06	0.02	0.04
4	0.02	0.08	0.06
5	0.08	0.08	0.00
6	0.14	0.10	0.04
7	0.12	0.08	0.04
8	0.04	0.02	0.02
9	0.18	0.20	0.02
10	0.10	0.06	0.04

$\bar{R} = \Sigma R/n = 0.32/10 = 0.032$

$\Delta = \bar{R}/d_2 = 0.032/1.128 = 0.02840$

$3\Delta = 3 \times 0.0284 = 0.085$

$3\Delta/\text{Tol.} \times 100 = \% \text{ of tolerance}$

$0.085/0.2 \times 100 = 42.6\%$

Principal differences are: Linear example is 6Δ , while for position (\varnothing), it is 3Δ due to resultant value multiplied by 2.

Figure 25-2 Sample drawing #2

Figure 25-3 Sample drawing #3

25-4 Chapter Twenty-five

Based on the prior example, first impression might be to use only the linear displacement values to stay consistent with past and present Six Sigma conventions. If only things were this simple, but they are not. In addition to the examples shown, there are many types of geometric callouts that require further analysis of calculations to determine the most appropriate method of representing percentage of variables gaging influence.

The following is a beginning list of various types of geometric callouts that will need to be considered.

- 1) Geometric controls @ RFS (diametral and nondiametral).
- 2) Geometric controls @ maximum material condition (MMC) or least material condition (LMC) (diametral and nondiametral).
- 3) Geometric controls @ MMC or LMC in relationship to datums that are features of size also defined at MMC or LMC.
- 4) Geometric controls @ MMC or LMC with zero tolerance

Additional things not defined adequately deal with ranges for the following:

- 1) Features of size (lengths, widths, and diameters)
- 2) Linear plane to axis measurements
- 3) Axis (I.D.) to axis measurements

There are also questions as to which analysis methods to use (e.g., Western Electric, IBM, other). Also, what are the benefits, drawbacks and limitations of any of these methods?

Also, an acceptable method is needed to determine the bias of a measurement device with an acceptable artifact, as well as a method to determine bias between devices. Such a method must consider the following:

- 1) Sampling strategies
- 2) Spot size versus spacing versus sampling effects on a given feature
- 3) Replication of test (time versus environmental)
- 4) Confidence intervals
- 5) Truth (conformance to ASME Y14.5M-1994 and ASME Y14.5.1M-1994)

Note: For all geometric controls, the tolerance defined in the feature control frame is a “total tolerance,” of which the targeted value is “always” zero (0), and the upper control limit is always equal to the total tolerance defined (unless bonus tolerance is gained due to MMC or LMC on the considered feature).

For geometric controls, such as the one shown in Fig. 25-4, the 5 mm \pm 0.2 mm diameter is positioned within a diametral tolerance zone of 0.02 mm at its maximum material condition, in relationship to datums A (primary), B (secondary), and C (tertiary). The following analysis is proposed:

Drawing Example

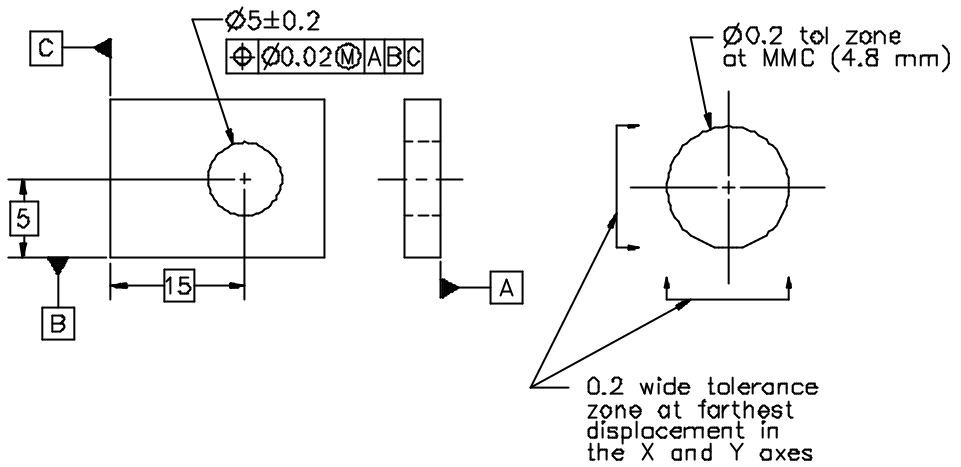

Figure 25-4 Sample drawing #4

The example shown in Fig. 25-3 was for a nondiametral positional tolerance. The example in Fig. 25-4 is a diametral positional tolerance. If this tolerance were defined at RFS rather than MMC, the procedure would be identical to the one shown in support of Fig. 25-3. The exception would be two additional columns to represent the y-axis displacement from nominal. In the example shown in Fig. 25-4, the 0.02 mm diametral tolerance zone applies only when the diameter of 5 mm is at its MMC size (4.8 mm). As it changes in size toward its LMC size (5.2 mm), bonus tolerance is gained, as shown in the following matrix.

Table 25-2 Bonus tolerance gained due to considered feature size

Feature of Size	Allowable Position Tol.
Ø5 +/- 0.2	Ø0.2
Ø4.8 (MMC)	Ø0.2
Ø4.9	Ø0.2 + Ø0.1 = Ø0.3
Ø4.95	Ø0.2 + Ø0.15 = Ø0.35
Ø5.0	Ø0.2 + Ø0.2 = Ø0.4
Ø5.1	Ø0.2 + Ø0.3 = Ø0.5
Ø5.2 (LMC)	Ø0.2 + Ø0.4 = Ø0.6
Ø5.3	Bad Part

Based on current methods of calculation, it is necessary to define the total tolerance zone as a constant. To do this, and also to take advantage of the bonus tolerance gained from this feature of size as it deviates from its MMC, there is need for alternative methods of analysis. The following matrix is a proposed method of analysis. (See Table 25-3.)

Table 25-3 Analysis Matrix

Part#	Run #1					
	X - Axis Displacement	Y - Axis Displacement	*Calculated* Resultant Value (C.R.V.) for Run #1 $2\sqrt{\Delta x^2 + \Delta y^2}$	Actual Size of Feature $\phi 5 \pm 0.2$ mm	Displacement in Size from MMC. (MMC = $\phi 4.8$ mm)	*Modified Resultant Value* (M.R.V.) for Run #1. MRV = less than 0
1	0.06	0.08	0.2	4.95	0.15	0.05
2	0.02	0.03	0.072	4.85	0.05	0.022
3	0.04	0.04	0.113	4.9	0.1	0.013
4	0.07	0.06	0.184	4.9	0.1	0.084
5	0.03	0.05	0.117	4.9	0.1	0.017
6	0.04	0.02	0.089	4.85	0.05	0.039
7	0.05	0.04	0.128	4.9	0.1	0.028
8	0.03	0.01	0.063	4.85	0.05	0.013
9	0.01	0.03	0.063	4.85	0.05	0.013
10	0.02	0.01	0.045	4.85	0.05	0.0

Part#	Run #2						
	X - Axis Displacement	Y - Axis Displacement	*Calculated* Resultant Value (C.R.V.) for Run #2 $2\sqrt{\Delta x^2 + \Delta y^2}$	Actual Size of Feature $\phi 5 \pm 0.2$ mm	Displacement in Size from MMC. (MMC = $\phi 4.8$ mm)	*Modified Resultant Value* (M.R.V.) for Run #2. MRV = less than 0	Range = difference between MRV #1 and MRV #2
1	0.05	0.07	0.172	4.95	0.15	0.022	0.028
2	0.02	0.04	0.089	4.9	0.1	0.0	0.022
3	0.04	0.04	0.113	4.9	0.1	0.013	0.0
4	0.07	0.05	0.172	4.9	0.1	0.072	0.012
5	0.04	0.04	0.113	4.9	0.1	0.013	0.004
6	0.03	0.03	0.085	4.85	0.05	0.035	0.004
7	0.05	0.05	0.141	4.9	0.1	0.041	0.013
8	0.04	0.02	0.089	4.85	0.05	0.039	0.026
9	0.01	0.02	0.045	4.85	0.05	0.0	0.013
10	0.02	0.02	0.056	4.85	0.05	0.006	0.006

$$\bar{R} = \Sigma R/n = 0.128/10 = 0.0128$$

$$s = \bar{R}/d_2 = 0.0128/1.128 = 0.0113$$

$$3s = 3 \times 0.0113 = 0.340$$

$$3s/\text{Tol.} \times 100 = \% \text{ of tolerance}$$

$$0.34/0.2 \times 100 = 17.02 \%$$

25.3 Summary

This chapter defined opportunities that will spur future research activities and should have made clear many of the steps needed to determine a measurement system capability along with the reasons for strict and aggressive controls. Discussions have started in 1998 within standards committees and universities to concentrate resources to research and develop standards, technical reports, and other documentation to further advance these analysis methods.

25.4 References

1. Hetland, Gregory A. 1995. Tolerancing Optimization Strategies and Methods Analysis in a Sub-Micrometer Regime. Ph.D. dissertation.
2. The American Society of Mechanical Engineers. 1995. *ASME Y14.5.1M-1994, Mathematical Definition of Dimensioning and Tolerancing Principles*. New York, New York: The American Society of Mechanical Engineers.
3. The American Society of Mechanical Engineers. 1995. *ASME Y14.5M-1994, Dimensioning and Tolerancing*. New York, New York: The American Society of Mechanical Engineers.