

---

# CHAPTER 9

---

## PLUMBING SYSTEMS

---

This chapter describes various interior plumbing systems and provides the system design criteria necessary for accurate and cost-effective sizing of equipment and piping for each of the systems. For a continuation of some of these systems outside of a building on the site, refer to Chap. 6, Site Utility Systems, for potable water supply, sanitary drainage, and storm water disposal.

### **GENERAL**

---

Plumbing systems directly affect the health and safety of the public, and thus are distinguished from other piping systems by the following general requirements:

1. The design, materials, and installation of the systems are directly regulated by a plumbing code.
2. System design must be approved by an authorized code official charged with the responsibility of ensuring plumbing code compliance.
3. A permit for installation of the systems must be obtained from the authority having jurisdiction.
4. The systems shall be installed by an individual duly licensed by the authority having jurisdiction for determining the competence of an individual to obtain a plumbing installation license. This may not be required in some jurisdictions.
5. The installed systems must be inspected and approved by an authorized code official charged with the responsibility of code enforcement.

The basic plumbing systems are

1. Sanitary drainage
2. Sanitary vent
3. Storm water drainage
4. Potable water
5. Fuel gas (Refer to Chap. 13.)

## **CODES AND STANDARDS**

---

Plumbing codes establish minimum acceptable standards for the design and installation of the various plumbing systems and for the components that compose them. There are six regional building codes that, along with their associated plumbing codes, have found general acceptance over various large areas of the country. They are

1. Building Officials Code Authority (BOCA), plumbing code: BOCA National Plumbing Code
2. International Association of Plumbing and Mechanical Officials (IAPMO), plumbing code: Uniform Plumbing Code
3. National Association of Plumbing-Heating-Cooling Contractors (PHCC), plumbing code: National Standard Plumbing Code
4. Southern Building Code Congress International (SBCCI), plumbing code: National Standard Plumbing Code
5. Council of American Building Officials (CABO), plumbing code: One- and Two-Family Dwelling Code
6. International Conference of Building Officials (ICBO), plumbing code: Uniform Plumbing Code
7. International Plumbing Code (IPC)
8. National Plumbing Code (A40)

Some states and large cities have adopted codes other than these building codes. In addition, some local authorities using specific regional building codes have adopted plumbing codes other than the one usually associated with that building code. Because of this nonstandardization, the plumbing code required to be used for each specific project must be obtained from a responsible code official.

The information pertaining to those systems included in the approved local plumbing code is the primary criteria for accepted methods and sizing. The tables and charts appearing in this chapter are used only to illustrate and augment discussions of sizing procedures and design methods, and should not be used for actual design purposes.

There are many nationally recognized standards that establish dimensions, manufacturing methods, material composition, tests, and numerous other details specific to individual components of the plumbing system. A partial list of organizations originating such standards adapted by various plumbing codes are

- American National Standards Institute (ANSI)
- American Society of Mechanical Engineers (ASME)
- American Society of Sanitary Engineers (ASSE)
- American Society of Testing and Materials (ASTM)
- American Water Works Association (AWWA)
- American Welding Society (AWS)
- Cast Iron Soil Pipe Institute (CISPI)
- National Fire Protection Association (NFPA)
- National Sanitation Foundation (NSF)

- Plumbing and Drainage Institute (PDI)
- Underwriters Laboratories (UL)

## **FIXTURE UNITS**

---

The *fixture unit* (FU) is an arbitrary, comparative, and dimensionless value assigned to a specific plumbing fixture, device, or piece of equipment. FU values represent the probable flow the fixture will discharge into a drainage system or use (demand) from a potable water supply system, compared to other fixtures.

The use of fixture units for plumbing systems was expanded upon by the late Roy B. Hunter of the former Bureau of Standards. If the original criteria were used, the results would be oversized water and drainage systems, since new fixtures have been developed and changes in the patterns of water use and conservation have evolved. Since the development of the Hunter Method, long-term data and modern statistical methods and analyses have resulted in revised figures, which are used for this book.

Since sanitary discharge and water demand FUs are different, the designation DFU for *drainage fixture units* and WFU for *potable water fixture units* will be used to differentiate between them.

Table 9.1 lists average drainage and vent DFUs, hot and cold water WFUs, and branch size information for typical fixtures.

## **PLUMBING FIXTURES**

---

A plumbing fixture is any approved receptacle specifically designed to receive human and other waterborne waste and discharge that waste directly into the sanitary drainage system, usually with the addition of water. Ideal fixture materials should be nonabsorbent, nonporous, nonoxidizing, smooth, and easily cleaned.

Plumbing codes usually mandate the number and type of fixtures that must be provided for specific building usage, based on the proposed population. Provisions for the handicapped have been made an integral part of code requirements, mandating the number and layout of and barrier-free access to those fixtures.

Potable water discharged from specific plumbing fixtures may be restricted to a maximum flow rate mandated by water conservation requirements. Refer to specific code provisions for these restrictions.

## **EQUIVALENT LENGTH OF PIPING**

---

When calculating the pressure loss through a pressurized piping system, one of the factors to be considered is the equivalent length of pipe. This is the actual pipe run plus an additional length, expressed as a number of feet of straight pipe that would have the same friction loss as that occurring through various fittings, valves, and so on. Figure 9.1 gives the straight run of pipe for both water and gas systems equal to various valve types and fittings for different pipe sizes. A popular and

**TABLE 9.1** Typical Plumbing Fixture Schedule\*

Fixture type	Drainage			Water			Flow, gpm†
	DFU	Size		WFU	Size		
		Trap	Vent		Cold	Hot	
Automatic clothes washer	3	2	1½	2	½	½	5
Bathroom group (WC, LAV, SH/BT) FV	8			8			
Bathroom group (WC, LAV, SH/BT) tank	6			6			
Bathtub (BT), with or without SH	2	1½	1½	2	½	½	5
Bidet	1	1¼	1¼	1	½		2
Clinic sink	6	3	1½	2	½	½	3
Dishwasher, domestic	2	1½	1½	1	½	½	3
Dental lavatory, cuspidor and unit	1	1½	1½	1	½	½	1
Drinking fountain	½	1¼	1¼	½	½		1½
Floor drain	5	3	1½				
Kit. sink & tray, with food grinder	4	2	1½	2	½	½	3
Kit. sink & tray, single 1½ trap	2	1½	1½	2	½	½	3
Kit. sink & tray, multiple 1½ traps	3	1½	1½	2	½	½	3
Lavatory, private	1	1¼	1¼	1	¾	¾	2
Lavatory, public	2	1¼	1¼	2	¾	¾	2
Laundry tray, 1 or 2 compartments	2	1½	1½	2	½	½	5
Shower (SH) per head or stall	2	2	1½	2	½	½	3
Service sink (SS), trap standard	3	3	1½	3	¾	¾	4
Service sink, P trap	2	1½	1½	2	½	½	4
Sink, pot & scullery	2	1½	2	2	½	½	4½
Sink, bar	1½	1½	1½	1	½	½	2
Sink, flushing rim	6	3	1½	5	1		15–30
Sink, surgeon's	3	2	1½	2	½	½	2½
Sink, wash fountain, per faucet	2	1½	1½	2	½	½	2½
Urinal pedestal, blowout	6	3	1½	10	1		15–40
Urinal washout	4	2	1½	5	¾		10–20
Water closet private flush valve	6	3	1½	10	1		15–40
Water closet private tank type	4	3	1½	5	½		3–5
Water closet private pressure tank	4	3	1½	4	½		3–5
Water closet public flush valve	6	3	1½	10	1		15–40
Water closet public tank type	4	3	1½	5	½		3–5
Water closet public pressure tank	4	3	1½	4	½		3–5
Fixture not listed	1	1¼	1¼				
Fixture not listed	2	1½	1½				
Fixture not listed	3	2	1½				
Fixture not listed	5	3	1½				
Fixture not listed	6	4	2				
Hose bibb or sill cock, public				5	¾		5
Hose bibb or sill cock, private				3	½		3
Water supply not listed				1	¾		
Water supply not listed				2	½		
Water supply not listed				3	¾		
Water supply not listed				10	1		

\*Refer to Table 2.9 for conversion of NPS to DN pipe sizes.

†1 GPM = 3.8 l/M or 0.63 l/S

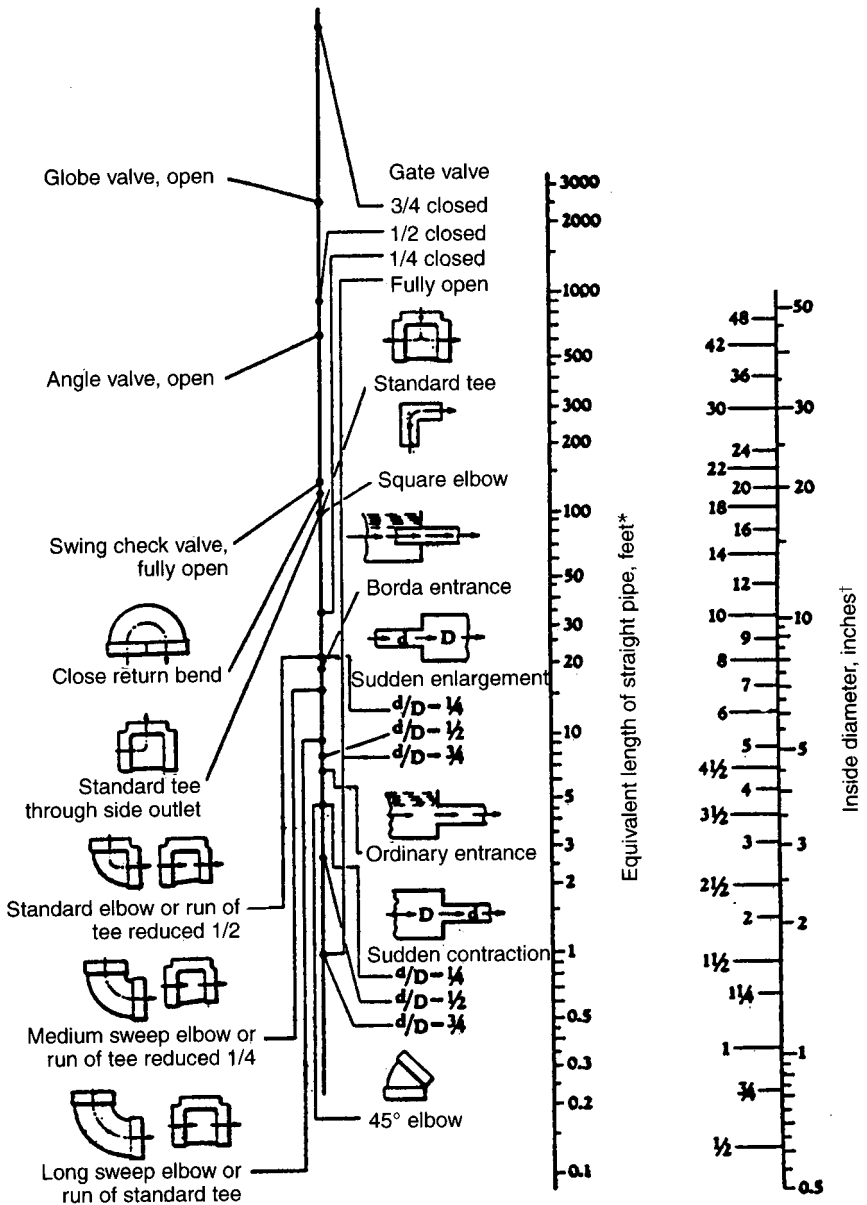

FIGURE 9.1 Equivalent lengths of pipe for valves and fittings. Note: For sudden enlargements or sudden contractions, use the smaller diameter on the nominal pipe size scale.

\*1 ft = 0.3 m.

†For conversion of NPS to DN pipe size, refer to Table 2.9.

conservative method of quickly finding the equivalent run is to add 50 percent to the actual measured pipe run.

### ***VELOCITY OF WATER***

---

It is generally accepted practice to limit the velocity of water in commercial establishments, such as office buildings, to approximately 6 to 8 ft per second (fps) (1.8 to 2.4 m/s). The primary reason is to reduce the noise produced by the water flowing in pipes. For theaters and other quiet facilities, 2 to 4 fps (0.6 to 1.2 m/s) should be maintained. Where quick closing valves are installed, a maximum velocity of 4 fps (1.2 m/s) is recommended to reduce water hammer. Industrial facilities, where noise is not a factor, could have a velocity of up to 12 fps (4 m/s), which is the highest generally thought not to produce erosion of the piping network.

# SANITARY DRAINAGE

## SYSTEM DESCRIPTION

The sanitary drainage system conveys waterborne effluent discharged from plumbing fixtures and other equipment to an approved point of disposal. The sanitary system receives all liquid waste except storm water or unacceptably treated process or chemical drainage. This effluent must be treated prior to liquid discharge into the environment. Treatment can be accomplished by either a public utility or treatment on site by a private plant that must receive approval from authorities having jurisdiction.

## MAJOR SYSTEM COMPONENTS

### Cleanouts

Codes mandate that cleanouts generally be provided at the base of stacks before the pipe changes direction from vertical to horizontal, at changes in horizontal pipe direction greater than  $45^\circ$  and along horizontal runs of pipe every 50 ft (15 m). Typical cleanouts are illustrated in Fig. 9.2a and cleanout components in Fig. 9.2b.

### Floor Drains

A floor drain is a receptacle used to remove liquid effluent from building interior floor areas and other similar locations. A typical floor drain is illustrated in Fig.

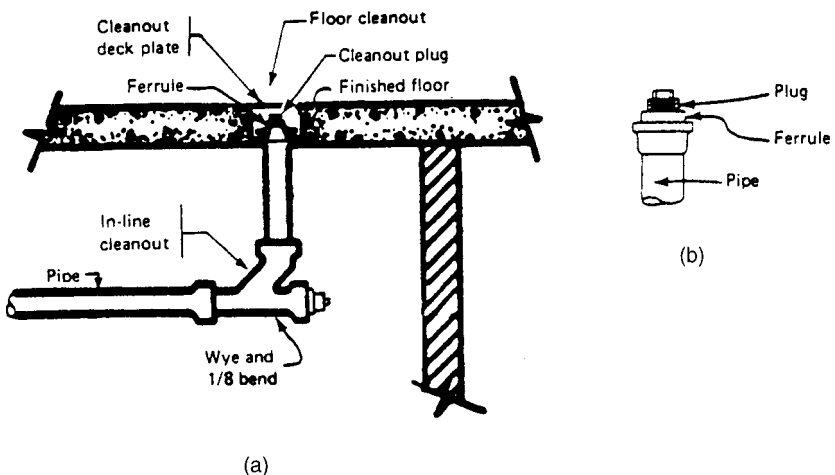

FIGURE 9.2 (a) Typical cleanouts; (b) cleanout components. (Courtesy of Jay R. Smith Co.)

9.3. It provides a receptacle for spills, washdown, and effluent to be collected and routed directly into the sanitary drainage piping system. Code provisions do not specify where a drain should be located. However, most codes regulate the minimum seal requirements for drain traps, the minimum open area of grates and strainers, and the mandatory inclusion of certain individual components (such as removable secondary strainers or sediment buckets) for drains in some locations. A standard commonly cited in the selection of floor drains is ANSI A112.21-1, Floor Drains. Drains consist of the following components:

1. Drain body
2. Grates located at the top of a drain permit liquid effluent to enter the drain body, while excluding larger solids and foreign matter. Grates are classified as follows:
  - a. Light-duty: foot traffic only
  - b. Medium-duty: live wheel loads up to 2000 lb (4400 kg)
  - c. Heavy-duty: live wheel loads up to 5000 lb (11,000 kg)
  - d. Extra-heavy-duty: live wheel loads of more than 5000 lb (11,000 kg)
3. A secondary strainer may be installed below the grate in a drain that does not have a sediment trap.
4. A sediment trap (or bucket) is a removable device inside the drain body that may be installed to trap and retain small solids that pass through the grate.
5. A flashing ring or clamp is a device used to secure flashing directly to the body of the drain.

### Interceptors

Plumbing codes require that any substance harmful to the building drainage system, the public sewer, or the municipal sewage treatment process be prevented from being discharged into the public sewer system. Such materials are grease, flammable liquids, sand, and other substances designated by the local authorities. Another reason to provide an interceptor is to recover any precious material or valuable substance that may be lost through discharge into the drainage system. Interceptors are discussed in Chap. 3.

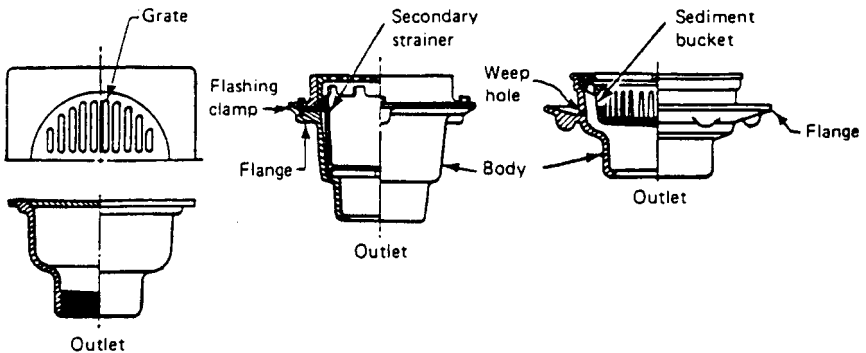

FIGURE 9.3 Typical floor drains.

## Traps

A fixture trap (Fig. 9.4) is a U-shaped section of pipe of the necessary depth to retain sufficient liquid as required by code. It prevents odors that originate in the drainage system from being discharged from the fixture and provides a seal to stop vermin passage. All direct connections into the sanitary drainage system are required to have traps.

In general, traps must (1) be self-cleaning, (2) provide a liquid seal of at least 2 in with larger seals where required, (3) conform to local code requirements regarding minimum size, (4) provide an accessible cleanout, and (5) be capable of rapidly draining a fixture. All traps must be vented in some manner, except for specific conditions waived by local code requirements or authorities.

Traps that are prohibited by code include traps requiring moving parts to maintain the seal, full S-type traps (Fig. 9.5), crown vented traps (Fig. 9.6), and drum traps (Fig. 9.7). Drum traps may be permitted by some codes for special use sinks, such as in laboratories. The branch drainage line extending from the trap to the vent is called the trap arm (Fig. 9.8). The maximum length of the trap arm is shown in Table 9.2.

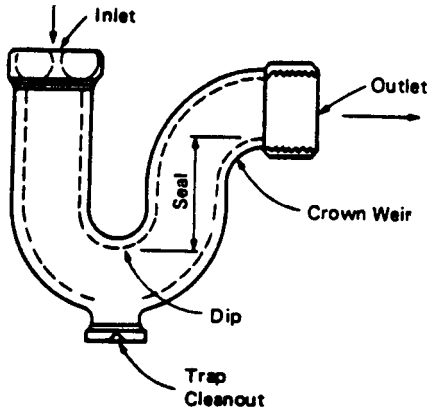

FIGURE 9.4 Typical fixture trap.

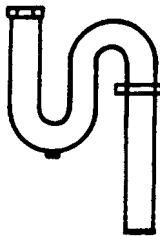

FIGURE 9.5 Full S trap.

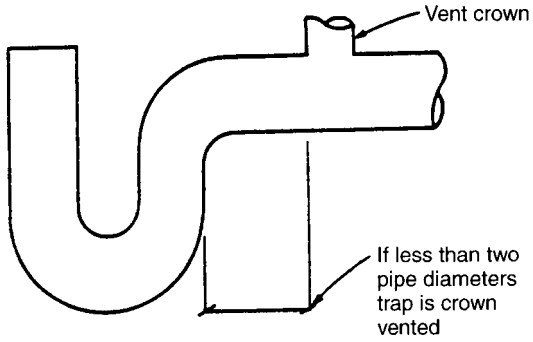

FIGURE 9.6 Crown vented trap.

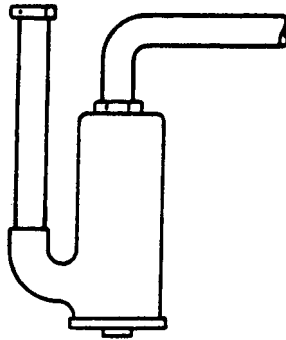

FIGURE 9.7 Drum trap.

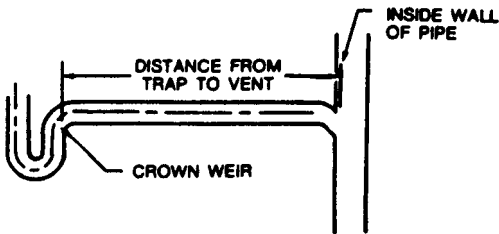

FIGURE 9.8 Detail of trap arm.

**TABLE 9.2** Maximum Length of Trap Arm

MM	Diameter of trap arm, in	Distance of trap to vent, ft	M
32	1¼	3½	1.4
40	1½	5	1.5
50	2	8	2.4
75	3	10	3
100	4	12	3.6

## **SANITARY SYSTEM DESIGN**

The design of the gravity drainage piping system is strictly regulated by the applicable plumbing code. All codes include charts similar to those presented here, which permit the design engineer to properly size all horizontal and vertical pipes based on the accumulated fixture unit discharge and slope of the pipe.

The pitch of the drainage system must provide sufficient velocity to produce a scouring action that will convey all solids along with the liquid stream. The recommended minimum velocity for ordinary sewage is 2 fps (0.6 m/s) to prevent the settlement of solids out of the effluent stream. When grease is suspended in the effluent, the velocity should be at least 4 fps (1.2 m/s).

Accepted practice for low-rise buildings with relatively uniform discharge is to size horizontal drainage lines to flow half full under average design conditions. High-rise buildings produce higher velocities and turbulence in building drains that can fill portions of the piping system as much as two-thirds full, with completely full pipes expected for short distances at stack runouts.

The following is a simplified method for sizing the drainage piping system:

1. Establish the location, size, and invert of the point of ultimate disposal of sanitary effluent. Determine if sump or ejector systems will be required and locate them.
2. Locate and lay out branch lines, stacks, and the house sewer.
3. Start with the individual device or fixture at the farthest and most remote point of the system or branch for which the code specifies two drainage values. The first is the drainage fixture unit (DFU) value that will be used to size the drainage piping system. For this value, refer to Table 9.1. The second is a minimum size of the trap, which is the minimum individual branch pipe size. Refer to Table 9.1 for typical values. If a fixture or device is not listed, use either the unlisted value based on the trap size or ask the local code official for the accepted value.
4. The size of the horizontal drainage line is determined by both the pitch of the drainage line and the accumulated total number of DFUs discharging into it. Refer to Table 9.3 for sizes of branch lines. When the drainage line is considered a main building drain or building sewer, refer to Table 9.4 for the size of building drains and sewers.
5. To determine the size of a drainage line based on a given flow in gpm rather than DFUs, refer to Table 9.5. Use the appropriate pitch and velocity combinations necessary to select a size. When there is a combination flow of both DFUs and gpm into a horizontal line or stack, generally accepted practice is to assign 2 DFUs for each gpm in order to use the code charts to determine a size based on DFUs.

**TABLE 9.3** Drainage Branches and Stacks*Maximum number of fixture units that may be connected to:*

Diameter of pipe, in¶	Any horizontal fixture branch,* DFU	One stack of three branch intervals or less, DFU	Stacks with more than three branch intervals	
			Total for stack,‡ DFU	Total at one branch interval, DFU
1½	3	4	8	2
2	6	10	24	6
2½	12	20	42	9
3	20†	48†	72†	20†
4	160	240	500	90
5	360	540	1100	200
6	620	960	1900	350
8	1400	2200	3600	600
10	2500	3800	5600	1000
12	3900	6000	8400	1500
15	7000			

\*Does not include branches of the building drain.

†Not more than 2 water closets or bathroom groups within each branch interval nor more than 6 water closets or bathroom groups on the stack.

‡Stacks shall be sized according to the total accumulated connected load at each story or branch interval and may be reduced in size as this load decreases to a minimum diameter of ½ of the largest size required.

¶See Table 9.1.

**TABLE 9.4** Building Drains and Sewers\**Maximum number of fixture units that may be connected to any portion of the building drain or the building sewer*

Diameter of pipe, in†	Slope			
	¼ in/ft .5 cm/m	⅜ in/ft 1 cm/m	½ in/ft 2 cm/m	¾ in/ft 4 cm/m
2			21	26
2½			24	31
3			42‡	50‡
4		180	216	250
5		390	480	575
6		700	840	1,000
8	1,400	1,600	1,920	2,300
10	2,500	2,900	3,500	4,200
12	2,900	4,600	5,600	6,700
15	7,000	8,300	10,000	12,000

\*On-site sewers that serve more than one building may be sized according to the current standards and specifications of the Administrative Authority for public sewers.

†See Table 9.1.

‡Not over two water closets or two bathroom groups, except that in single family dwellings, not over three water closets or three bathroom groups may be installed.

**TABLE 9.5** Drainage Discharge Rates of Sloping Pipes, gpm*Flowing half-full\***Discharge rate and velocity‡*

Actual inside diameter of pipe, in‡	Slope							
	1/16 in/ft .5 cm/m		1/2 in/ft 1 cm/m		1/4 in/ft 2 cm/m		1/2 in/ft 4 cm/m	
	Discharge, gpm¶	Velocity, fps§	Discharge, gpm	Velocity, fps	Discharge, gpm	Velocity, fps	Discharge, gpm	Velocity, fps
1 1/4							3.40	1.78
1 3/8					3.13	1.34	4.44	1.90
1 1/2					3.91	1.42	5.53	2.01
1 5/8					4.81	1.50	6.80	2.12
2					8.42	1.72	11.9	2.43
2 1/2			10.8	1.41	15.3	1.99	21.6	2.82
3			17.6	1.59	24.8	2.25	35.1	3.19
4	26.70	1.36	37.8	1.93	53.4	2.73	75.5	3.86
5	48.3	1.58	68.3	2.23	96.6	3.16	137.0	4.47
6	78.5	1.78	111.0	2.52	157.0	3.57	222.0	5.04
8	170.0	2.17	240.0	3.07	340.0	4.34	480.0	6.13
10	308.0	2.52	436.0	3.56	616.0	5.04	872.0	7.12
12	500.0	2.83	707.0	4.01	999.0	5.67	1413.0	8.02

\*Half-full means filled to a depth equal to one-half of the inside diameter.

†Computed from the Manning formula of 1/2-full pipe,  $n = 0.015$ . For 1/4 full: multiply discharge by 0.274; multiply velocity by 0.701. For 3/4 full: multiply discharge by 1.82; multiply velocity by 1.13. For full: multiply discharge by 2.00; multiply velocity by 1.50. For smoother pipe: multiply discharge and velocity by 0.015 and divide by  $n$  value of smoother pipe.

‡For conversion see Table 9.1. 1 gpm = 3.8 L/m. § 1 fps = 0.3 m/s.

- The size of a stack is governed by the total DFU discharge into it and its height. Refer to Table 9.3 using the applicable column and the total number of DFUs for the stack to find the stack size.
- To size a stack based solely on gpm, refer to Table 9.6. Two generally accepted recommendations regarding the maximum proportion of cross-section area that may be occupied with water flowing down a stack are 1/4 and 7/24, depending on

**TABLE 9.6** Drainage Stack Capacity, gpm\*

Pipe diameter, in†	1/4 Full	7/24 Full
1 1/4	5	6.5
1 1/2	8.1	10.5
2	17.5	22.6
2 1/2	31.8	41
3	52.1	67.2
4	111	143
5	202	261
6	336	423
8	709	915

\* 1 gpm = 3.8 L/m

† See Table 9.1.

the code used and the requirements of the local authority having jurisdiction. Separate columns are provided for each of these two values. Accepted practice is to use the  $\frac{1}{4}$  full criteria, which closely matches the allowable flow from a horizontal pipe flowing full at  $\frac{1}{4}$  in pitch (2 cm/m).

8. If a stack should offset more than  $45^\circ$  from the vertical, the horizontal offset portion of the stack must be sized as a house drain. If the offset size is larger than that portion of the stack higher than the offset, the larger size must be carried down from the offset to the lower level. The portion of the stack above the offset may remain unchanged.
9. The purpose in differentiating between branch intervals and the actual number of horizontal soil or waste branch lines entering the stack is prevention of stack overloading in a short distance. Many codes limit the number of DFUs allowed in a branch interval.

Flow conditions in the offset portion of a stack create severe turbulence. Because of the resulting pneumatic effects, all branch connections that normally would be made at the level of the offset should be carried down 10 pipe diameters of the stack below the level of the offset.

When ultra low flush (ULF) water closets are required by code, care should be taken not to place these fixtures at the end of a long run with shallow pitch and few other fixtures available to provide sufficient water to create the necessary scouring action within the drainage pipe. Field experience has shown that this condition regularly produces stoppages.

## **SUDS PRESSURE AREAS**

---

Appliances and fixtures normally using detergents, such as kitchen sinks, bathtubs, showers, dishwashers, and clothes washers, can discharge a large quantity of detergents into the drainage system. When flowing through drainage piping, turbulence causes large amounts of suds to be generated. The suds accumulate in the lower portions of the drainage system, and can remain there for a considerable period of time. When additional liquids flow into these sections of the system, the suds are displaced and will follow the path of least resistance. Enough suds pressure can be built up to force the suds through a fixture trap. Suds pressure areas exist in the following parts of the drainage system, as illustrated in Fig. 9.9:

1. For an upper level stack offset serving fixtures on two or more floors above the offset, there are two suds areas. The first area (Fig. 9.9a) extends 40 pipe diameters of the stack upwards from the base of the offset. The second (Fig. 9.9b) extends 10 pipe diameters horizontally downstream from the point of change in direction.
2. For an upper level stack offset turning from horizontal back to vertical, there is one area (Fig. 9.9c) extending 40 pipe diameters of the stack upstream from the fitting changing direction from horizontal to vertical.
3. In the horizontal runout from a stack when the pipe changes direction horizontally with a fitting greater than  $45^\circ$ , there are two areas. The first (Fig. 9.9d) extends 40 pipe diameters of the horizontal pipe upstream from the change in direction. The second (Fig. 9.9e) is 10 pipe diameters downstream.

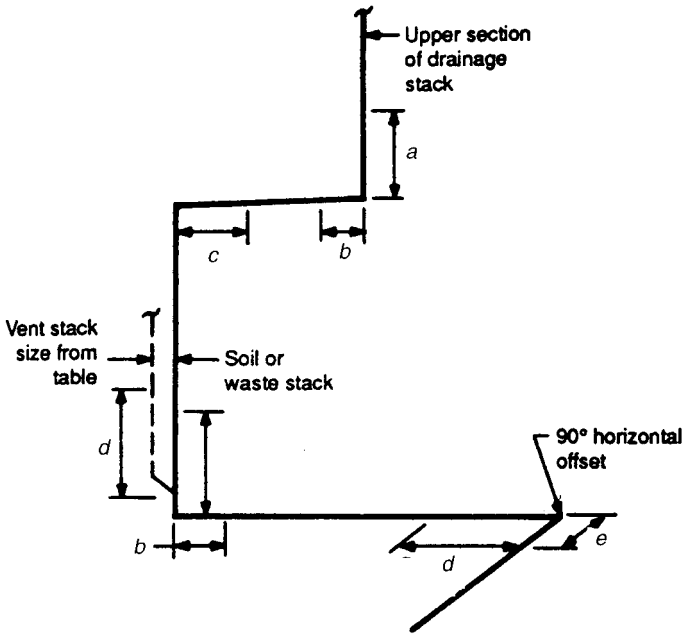

FIGURE 9.9 Suds pressure zones.

When suds pressure is anticipated, no pipe shall connect to any of the areas indicated as *a* to *e* in Fig. 9.9. Refer to Table 9.7 for actual distances based on pipe size.

## SUMP PUMPS AND SEWAGE EJECTORS

When liquid waste must be removed from a level below the ultimate point of disposal, sump pumps or sewage ejectors are used.

TABLE 9.7 Length of Pipe for Suds Pressure Connection

Pipe size, in*	40 diameters, ft†	10 diameters, ft
1	5	1½
2	7	1½
2	8	2
3	10	2½
4	13	3½
5	17	4
6	20	5

\* See Table 9.1.

† 1 ft = 0.3 m

The distinction between *sump* and *ejector* systems is mainly one of terminology, with the main difference being in the impeller. The impeller of the ejector pump is designed to pass solids. Sump pumps are primarily designed to transport turbid, nonsanitary waste water with smaller suspended solids. Ejector pumps are designed to transport sanitary waste with larger solids suspended in the effluent. Sump pumps designed to transport large quantities of nonsanitary water with larger suspended solids are sometimes referred to as *trash pumps*. The components of these systems are motors (drivers), impellers (pumps), basins (receivers), and controls.

Because pump failure could result in flooding the lower levels, it is highly recommended that two pumps be installed, each sized for full load and connected in parallel. This is referred to as duplex installation.

There are three systems of pumps generally used. These systems are categorized as follows:

1. Submersible pumps in a receiver (for a detail refer to Fig. 9.10)
2. Wet-pit receiver with vertical lift pumps (for a detail refer to Fig. 9.11)
3. Wet-pit receiver with cantilever, self-priming pumps (for a detail refer to Fig. 9.12)

Each system has specific advantages and disadvantages that must be evaluated based on the following major considerations:

1. Range of head and capacity for motor and impeller combinations
2. Initial cost
3. Floor space requirements
4. Materials available for pump and bearing construction
5. Ability to pump hot liquids

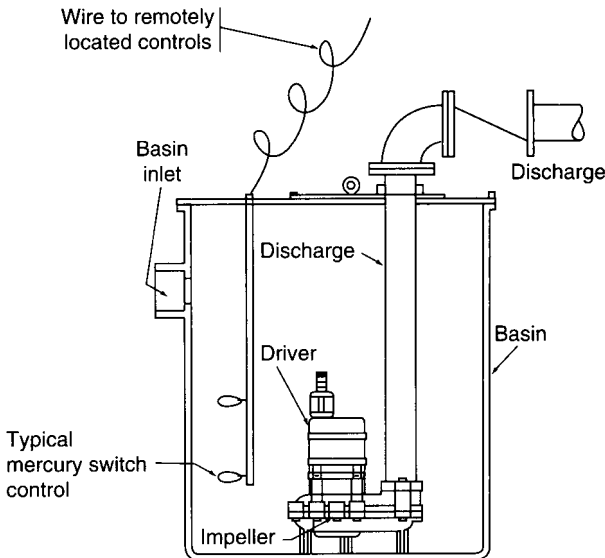

**FIGURE 9.10** Submersible pump system.

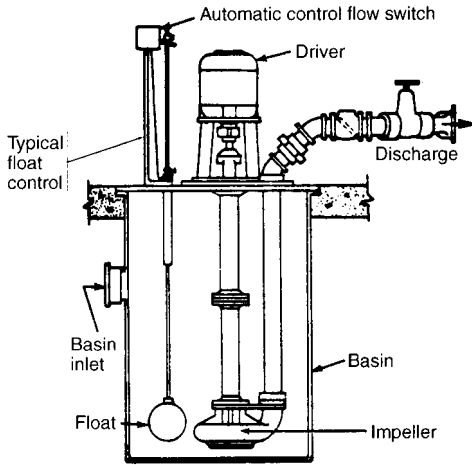

FIGURE 9.11 Vertical lift submerged pump system.

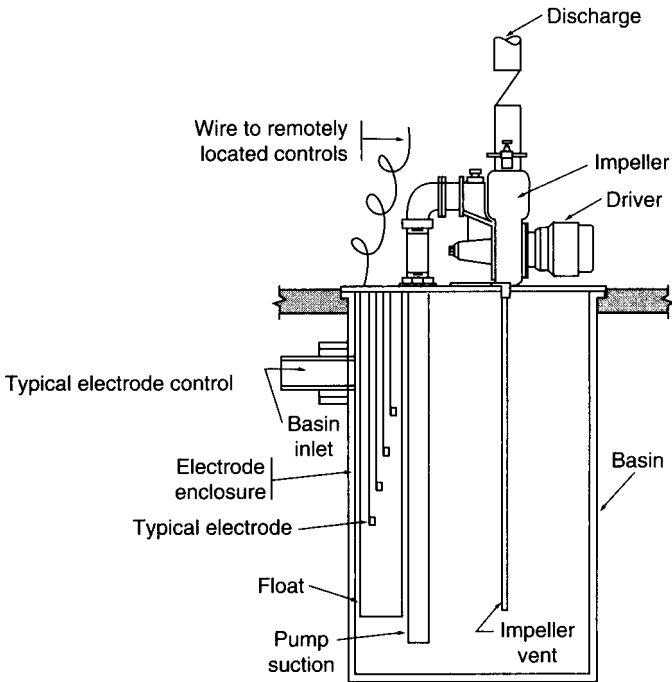

FIGURE 9.12 Cantilever type system.

6. Headroom required to remove pump and impeller
7. Ability to pump highly abrasive and corrosive effluent

Control of the operating cycle used to start and stop the pumps is based on the level of water in the basin. Alarms of the following types are also included in the control panel.

1. *Float*. This type uses a rod with an attached float on the surface of the effluent level, with a set point on the rod operating an exposed switch on the basin cover. Refer to Fig. 9.11 for a typical installation.
2. *Mercury switch*. This is a sealed, buoyant device containing mercury and integral contacts, attached at one end only and suspended at various levels inside the basin. As the effluent level rises and falls, so does the orientation of this device. The mercury then makes or breaks contact. Refer to Fig. 9.10 for a typical installation.
3. *Pneumatic*. This alarm is an inflated device suspended below the level of the effluent. The difference in pressure of the effluent on the inflated device is used to make or break remotely located contacts.
4. *Electrode type*. This alarm uses separate electrodes suspended in the effluent. As the level of effluent rises and falls, different sets of electrodes are immersed and send a signal to remotely located controls. Refer to Fig. 9.12 for a typical installation.
5. It is good practice to have one of these on a separate circuit. In addition, another alarm that is highly recommended is a *pump failure to start alarm light* for duplex installations. In many cases, if the first pump does not function, the second pump will automatically start and satisfy system requirements. Operating personnel will not know that the first pump has broken until the second pump breaks down and the entire pumping system does not function.

### **Submersible Type**

The submersible pump system is totally submerged in the effluent within the receiver. The pump can be directly joined to the discharge pipe or indirectly joined by using a proprietary coupling connected to it by gravity, thus permitting the entire assembly to be brought up to floor level for servicing without personnel having to enter the basin.

### **Vertical Lift Type**

The vertical lift system utilizes a vertical shaft centrifugal pump and separate driver, both mounted on the basin cover. The pump is immersed in the effluent and supported from under the cover by a special column that encloses the connecting shaft. The motor is independently supported on top of the cover directly over the pump.

### **Cantilever Type**

The cantilever, or wet-pit system, utilizes a horizontal centrifugal pump and close-coupled driver mounted on the receiver cover. A suction pipe is extended (or can-

tilivered) from the pump down into the receiver, so that the effluent can be lifted up to the level of the impeller intake.

### Pump and Receiver Design

*Pump head* is calculated by adding the static height from the bottom of the basin to a level 1 ft above the proposed highest point of discharge and the friction loss of effluent through the pump discharge piping system. The flow shall be calculated with both pumps running in a duplex installation.

The capacity of the pump is a function of the basin size. Generally accepted practice is to have a pump run from 1 to 5 min, with an optimum of six starts per hour. This is to avoid premature failure due to short cycling. If these conditions cannot be met, the least amount of starts should be used. This consideration shall be balanced against the cost of a basin sized to give fewer starts per hour.

To find the basin size, the space available for the basin must be considered, as well as the permissible depth. For duplex pumps, a diameter (or side) of 4 ft (1.2 m) is reasonable for most installations. Often, the basin is at the lowest area in the building, so depth is a factor. Refer to Table 9.8 for the capacity of various sized round and square basins.

To avoid overflow, the pump capacity should be capable of discharging the maximum possible inflow. This might result from a planned maintenance operation or the flow from the system itself. The flow from fixtures discharging into the basin is calculated from the gpm of the water supply (using WFUs from Tables 9.1 and 9.20 to convert to gpm), plus 10 percent. Known discharge might be condensate from HVAC or other equipment. A leakage rate from pumps of 2 to 5 gpm (8-20 l), depending on the size of the project, is reasonable.

To find the basin depth, use the following approximate dimensions as a guide, assuming duplex pumps and starting from the invert of the inlet pipe.

**TABLE 9.8** Capacity of Sump and Ejector Basins, Gallons per Foot Depth

Circular		Square	
Diameter, ft	Gallons	Side, ft	Gallons
2	23.50	2	30.00
2½	36.72	2½	45.00
3	52.88	3	67.50
3½	71.91	3½	90.00
4	94.00	4	120.00
4½	110.32	4½	149.60
5	146.89	5	187.00
6	158.64	6	270.00
7	170.00	7	365.50
8	181.00		
9	193.00		
10	204.00		

1 ft = 0.3 m.

1 gal = 3.8 L.

1. From the invert of the inlet pipe, allow 6 in to the high water alarm.
2. From the high water alarm, allow 6 in to pump 2 start.
3. From pump 2 start, allow 6 in to pump 1 start.
4. Below pump 1 start, the dimension of the liquid capacity depends on a 1- to 5-min operating period of the selected pump. The lower level of the storage portion is pump(s) stop. Refer to Table 9.8 for storage capacity.
5. Allow 6 in from pump stop to the inlet of the pump.
6. Allow 1 ft to the basin bottom from the inlet of the pump. This dimension varies between various manufacturers.

Sewage and waste effluent has the same hydraulic characteristics as water; therefore, the pump discharge piping should be sized using the same criteria as for potable water. Ejector discharge lines should be a minimum of 3 in and sump discharge lines should be a minimum of 2 in (DN 50) to prevent stoppages. Pipe sizing should be made larger (if cost effective) to lessen the friction loss in the piping system, if this would result in a reduction of the motor size.

## ***HOUSE SEWER DESIGN***

---

The house sewer is that portion of the sanitary drainage system outside the building, generally extending from the building wall to the ultimate point of disposal. This point is either a public sewer, private treatment facility (such as a septic tank and field), or small sewage treatment plant discharging into the environment. A public sewer must be used if it is available. The definition of what is considered available varies greatly, depending on local codes and regulatory agencies.

There may be additional regulatory agencies, other than the plumbing code officials, that have jurisdiction over the design and installation of the building sewer. Consult with the local code officials to find the various agencies from which approval must be obtained, and their requirements for approval. Design criteria for house sewers are given in Chap. 6.

# PRIVATE SEWAGE DISPOSAL SYSTEMS

## INTRODUCTION

This sub-section will discuss private sewage disposal systems. They are required if a public sewer is not considered available either by circumstance or by the authorities having jurisdiction. A common definition of "available" could mean that a public sewer is located more than 500 ft (150 m) from a building wall.

## CODES AND STANDARDS

1. Local and state codes and standards for private sewage disposal systems
2. International Private Sewage Disposal Code

## SEPTIC SYSTEM

### General

The collection and disposal of raw sanitary effluent where there are no sewers is by means of a private sewage disposal system. The most commonly used private method is a septic system consisting of a septic tank and a gravity flow soil absorption system illustrated in Fig. 9.13.

Most areas of the country have local regulations regarding the design and installation of the private sewage disposal system that must be followed. The examples given here are only general guidelines and illustrations of the criteria and methods to be used and, therefore, should not be used for actual project design purposes.

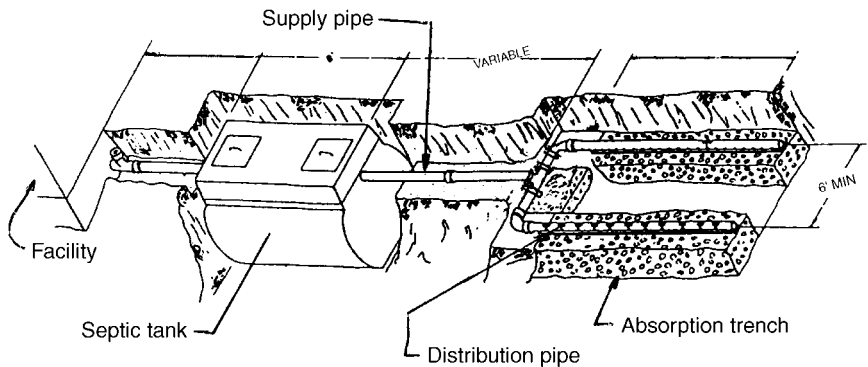

FIGURE 9.13 Typical septic system diagram.

## System Description

The septic system receives raw sewage and waste from a facility or private dwelling, provides a method for decomposition of most solids into liquid and disposes of the liquid by absorption into the soil adjacent to the facility.

Where food-related areas are located within a facility, a grease trap is required to keep the food-related grease from entering the septic tank. This does not include kitchens in private residences, although separate disposal of grease from this source is encouraged.

## Primary Collection and Treatment System

**Septic Tanks.** A septic tank is a large storage tank that protects the soil absorption system by collecting raw, untreated sewage effluent, decomposing fecal and other organic matter and separating other solids from the effluent stream. If this were not accomplished, the soil absorption system would quickly clog up and fail. The discharge from a properly designed septic tank is mostly liquid. A septic tank functions as follows.

1. Heavier suspended solids and organic (fecal) matter settle to the bottom of the tank as sludge. This accumulated bottom sludge undergoes a bioseptic process where bacterial digestion changes most of the particles into either a gas or liquid.

2. Lighter particles float to the top to collect there as a surface mat. An interchange of particles takes place between the top mat and bottom sludge, allowing the digesting bacteria to continuously rise and settle, acting on both the top and bottom areas of the tank. Sludge is defined as an accumulation of solids at the bottom of the septic tank. Scum is a partially submerged mat of floating solids that forms at the surface of the fluid in the septic tank.

3. The remaining suspended organic particles, mostly colloidal in nature, are subjected to a biological decomposition process transforming them into liquid particles. This permits leaching into the soils without any clogging effect. The bacteria present in the liquid area of a variety called anaerobic because they thrive in the absence of free oxygen. This decomposition, or treatment, of the sewage under anaerobic conditions is termed septic. Hence, the name of the system.

A single compartment septic tank will provide acceptable performance. The available data indicate, however, that a two-compartment septic tank (with the first compartment equal to one-half to two-thirds of the total volume) will provide a better suspended-solids removal, and this may be especially valuable for the protection of the soil absorption system. Septic tanks with three or more equal compartments will give at least as good performances as single compartment septic tanks of the same total capacity. Each tank compartment should have a minimum plan dimension of 2 ft (0.6 m) with a liquid depth ranging from 30 to 60 in (0.8 to 1.5 m).

An access manhole should be provided to each tank compartment. Venting between the tank compartments should be provided to allow the free passage of gas. Inlet and outlet fittings in the septic tank should be proportioned (as for a single tank). The same allowance should be made for storage above the liquid line (as in a single tank).

A vented inlet tee or baffle should be provided to divert the incoming sewage downward. This device should penetrate at least 6 in (150 mm) below the liquid

level of the septic tank, but in no case should the penetration be greater than that allowed for the outlet device.

It is important that the outlet piping arrangement penetrate just far enough below the liquid level of the septic tank to provide balance between the sludge and scum storage volume; otherwise, part of the capacity is lost. A vertical section of a properly operating septic tank would show it divided into three distinct layers: scum at the top, a middle zone free of solids (called clear space) and a bottom layer of sludge. Observations of the sludge accumulations in the field indicate that the outlet device should be extended to a distance below the surface equal to 40 percent of the liquid depth. The outlet device should be extended above the liquid line to approximately 1 in (25 mm) from the top of the septic tank. The space between the top of the septic tank and the baffle will allow any gas to pass through the septic tank into the house vent.

For private dwellings, the septic tank shall be sized on the number of bedrooms. In the absence of code requirements, use Table 9.9 as a guide. For other facilities, the starting point shall be a 750 gal (2850 L) tank to which an additional capacity is added. This additional capacity shall be as shown in Table 9.10. A typical septic tank is illustrated in Fig. 9.14.

**Soil Absorption System.** The soil absorption system receives the liquid discharge from the septic tank and, by means of supply piping, distributes the liquid into excavated trenches called absorption trenches. These trenches are designed and sized to adequately absorb the discharged liquid into the earth. The piping in the absorption trenches is called the distribution piping.

The successful operation of a subsurface waste disposal system requires a comprehensive site evaluation, good design criteria and careful installation. When evaluating a site the engineer must consider the following: lot size, soil, composition, slope, topography, surface water and the seasonal high-water table. Residential lot must be large enough to accommodate the projected area of seepage beds while maintaining minimum clearances from surface waters and wells, as mandated by local codes. In their absence, use Table 9.11 as a guide for residential properties.

For multiple dwellings, institutional, industrial and other types of facilities, it is common for codes to have separate formulas and absorption areas to allow for varying minimum daily flow for each type of facility. For a comprehensive listing of daily sewage flows from facilities other than private dwellings, refer to Table 6.25.

**TABLE 9.9** Septic Tank Capacity for One- and Two-Family Dwellings

Number of bedrooms	Septic tank (gallons)	Liters
1	750	3000
2	750	3000
3	1,000	4000
4	1,200	4800
5	1,425	5700
6	1,650	6600
7	1,875	7500
8	2,100	8400

**TABLE 9.10** Additional Capacity for Other Facilities

Building classification	Capacity (gallons)*
Apartment buildings (per bedroom—includes automatic clothes washer)	150
Assembly halls (per person—no kitchen)	2
Bars and cocktail lounges (per patron space)	9
Beauty salons (per station—includes customers)	140
Bowling centers (per lane)	125
Bowling centers with bar (per lane)	225
Campgrounds and camping resorts (per camp space)	100
Campground sanitary dump stations (per camp space) (omit camp spaces with sewer connection)	5
Camps, day use only—no meals served (per person)	15
Camps, day and night (per person)	40
Car washes (per car handwash)	50
Catch basins—garages, service stations, etc. (per basin)	100
Catch basins—truck washing (per truck)	100
Churches—no kitchen (per person)	3
Churches—with kitchen (per person)	7.5
Condominiums (per bedroom—includes automatic clothes washer)	150
Dance halls (per person)	3
Dining halls—kitchen and toilet waste—with dishwasher, food waste grinder or both (per meal served)	11
Dining halls—kitchen waste only (per meal served)	3
Drive-in restaurants—all paper service (per car space)	15
Drive-in restaurants—all paper service, inside seating (per seat)	15
Drive-in theaters (per car space)	5
Employees—in all buildings, per employee—total all shifts	20
Floor drains (per drain)	50
Hospitals (per bed space)	200
Hotels or motels and tourist rooming houses	100
Labor camps, central bathhouses (per employee)	30
Medical office buildings, clinics and dental offices	
Doctors, nurses, medical staff (per person)	75
Office personnel (per person)	20
Patients (per person)	10
Mobile home parks, homes with bathroom groups (per site)	300
Nursing and rest homes—without laundry (per bed space)	100
Outdoor sports facilities (toilet waste only—per person)	5
Parks, toilet wastes (per person—75 persons per acre)	5
Parks, with showers and toilet wastes (per person—75 persons per acre)	10
Restaurants—kitchen waste only—without dishwasher and food waste grinder (per seat)	9
Restaurants—toilet waste only (per seat)	21
Restaurants—kitchen and toilet wastes (per seating space)	30
Restaurants (24-hour)—kitchen and toilet wastes (per seating space)	60
Restaurants—dishwasher or food waste grinder or both (per seat)	3
Restaurants (24-hour)—dishwasher or food waste grinder (per seat)	6
Retail stores—customers	1.5
Schools (per classroom—25 pupils per classroom)	450
Schools with meals served (per classroom—25 pupils per classroom)	600
Schools with meals served and showers provided (per classroom)	750
Self-service laundries (toilet waste only, per machine)	50
Automatic clothes washers (apartments, service buildings, etc.—per machine)	300
Service stations (per car)	10
Showers—public (per shower taken)	15
Swimming pool bathhouses (per person)	10

\* 1 gal = 3.785 L.

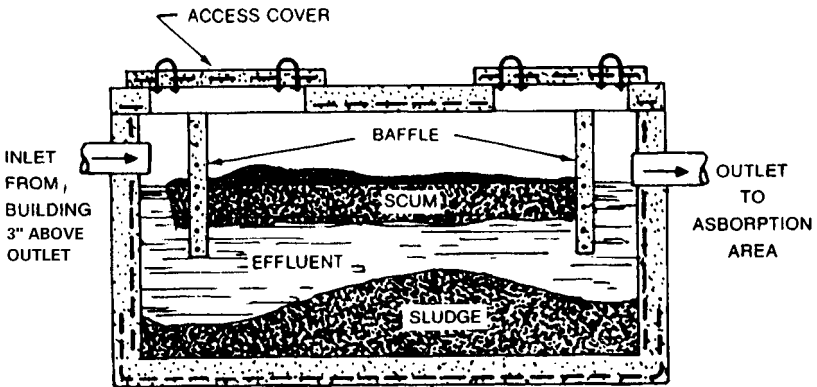

FIGURE 9.14 Typical septic tank.

TABLE 9.11 Distance from Objects to Soil Absorption Laterals

Object	Distance	
	feet	m
Cistern	50	15
Habitable building, below-grade foundation	25	7.6
Habitable building, slab-on-grade	15	4.5
Lake, high-water mark	50	15
Lot line	5	1.5
Reservoir	50	15
Roadway ditches	10	3.0
Spring	100	30
Streams or watercourse	50	15
Swimming pool	15	4.5
Uninhabited building	10	3
Water main	50	15
Water service	10	3
Water well	50	15

If gravity collection and/or distribution are not possible, pumped systems are used. When the area surrounding any facility is not suitable for excavated soil absorption methods, a mound system shall be provided.

**Guide for Estimating Soil Absorption Potential.** A percolation test is the only known means for obtaining a quantitative appraisal of the soil absorption capacity. However, observation and evaluation of soil characteristics can provide very useful clues to the relative capacity of a soil to absorb a liquid. Most suitable and unsuitable solids can be identified without additional testing.

The following information is required in order to make a full evaluation of the site.

1. *Soil Maps.* Soil survey reports, soil categories and maps are published by the U.S. Department of Agriculture.

2. *Clues to Absorption Capacity.* This is obtained by a close visual inspection of the soil.
3. *Texture.* Texture is generally defined as the relative proportion of sand, silt and clay in the soil. It is the most commonly used clue to the water absorption capacity. The larger the soil particles, the larger the pores and the faster the rate of absorption.
4. *Structure.* Soil structure is characterized by the grouping together of the textual particles, forming secondary particles of a larger size. The structure can easily be recognized by the manner in which a clod, or lump, breaks apart.

In general there are four fundamental structural types, named according to the shape of the aggregate particles: platy, prism-like, block-like and spherical. A soil without structure is generally referred to as massive. Spherical structure tends to provide the most favorable absorption properties, and platy structure, the least.
5. *Color.* If the soil has a uniform reddish-brown to yellow oxidized color, this indicates that there has been a free movement of the air and water in and through the soil. Such a soil has some desirable absorption characteristics. At the other extreme, soils that have a dull-gray or mottled coloring, indicating a lack of oxidizing conditions or a very restricted movement of the air and the water, have poor absorption characteristics.
6. *Depth (or thickness) of Permeable Strat.* The quantity of water that may be absorbed by the soil is directly proportional to the thickness (or volume) of the absorbent stratum, when all other conditions are alike.
7. *Swelling Characteristics.* Soils that shrink appreciably when dry are soils that may give trouble in a distribution field when they are wet.

### **Procedure for Percolation Tests**

***Number and Location of Tests.*** Six or more tests should be made in separate test holes, spaced uniformly over the proposed absorption field site.

***Type of Test Hole.*** Dig or bore a hole, with horizontal dimensions or diameter varying from 4 to 12 in (101.6 to 304.8 mm) and vertical sides to the depth of the proposed absorption trench. To save time, it is common practice to have the holes bored with a 4-in (101.6 mm) auger.

***Preparation of Test Hole.*** Carefully scratch the bottom and the sides of the hole with a knife blade or sharp-pointed instrument in order to remove any smeared soil surfaces and to provide a natural soil interface into which water may percolate. Remove all loose material from the hole. Add 2 in (50 mm) of coarse sand or fine gravel to protect the bottom from scouring and sediment.

There are several types (procedures) of percolation tests that are acceptable to most local administrative authorities. However, in this sub-chapter the procedure for percolation tests was developed at the Robert A. Taft Co.

***Saturation and Swelling of the Soil.*** It is important to distinguish between saturation and swelling. Saturation means that the void spaces between soil particles are full of water. This can be accomplished in a short period of time. Swelling is caused by intrusion of water into the individual soil particle. This is a slow process,

especially in clay-type soil, and is the reason for requiring a prolonged soaking period.

In the conduct of the test, carefully fill the hole with clear water to a minimum depth of 12 in (304.8 mm) over the gravel. In most soils, it is necessary to refill the hole by supplying a surplus reservoir of water, possibly by means of an automatic siphon, to keep water in the hole for at least 4 hours and preferably overnight. Determine the percolation rate 24 hours after water is first added to the hole. This procedure is to insure that the soil is given ample opportunity to swell and to approach the condition it will be during the wettest season of the year. Thus, the test will give comparable results in the same soil, whether made in a dry or in a wet season. In sandy soils containing little or no clay, the swelling procedures are not essential and the test may be made as previously described, after the water from one filling if the hole has completely seeped away.

**Percolation Rate Measurement.** With the exception of sandy soils, the percolation rate measurements should be made on the day following the procedure described under saturation and swelling of the soil.

1. If the water remains in the test hole after the overnight swelling period, adjust and depth to approximately 6 in (152 mm) over the gravel. From a fixed reference point, measure the drop in the water level over a 30-minute period. This drop is used to calculate the percolation rate.

2. If no water remains in the hole after the overnight swelling period, add clear water in order to bring the depth of the water in the hole to approximately 6 in (152 mm) over the gravel. From a fixed reference point, measure the drop in the water level at approximately 30-minute intervals for 4 hours, refilling 6 in (152 mm) over the gravel as necessary. The drop that occurs during the final 30-minute period is used to calculate the percolation rate of the soil. The lowering of liquid level during the prior periods provide the information for a possible modification of the procedure in order to suit any local circumstances.

3. In sandy soils (or other types of soils in which the first 6 in (152 mm) of water seep away in less than 30 minutes after the overnight swelling period), the time interval between the measurements should be taken as 10 minutes and the test should be run one hour. The drop that occurs during the final 10 minutes is used to calculate the percolation rate.

### **Soil Absorption System Design**

For areas where the percolation rates and the soil characteristics are good, the next step after making the percolation tests is to determine the required area of seepage trenches that will be satisfactory.

When a soil absorption system of seepage trenches is determined to be unusable, alternative types of systems should be considered by the engineer such as absorption trenches, seepage beds and seepage pits.

**Absorption Trench Design Criteria.** A leaching field is a number of absorption trenches called laterals, each containing distribution piping consisting of a length (or lengths) of 4-in (DN 100) agriculture drain tile of vitrified clay sewer pipe or perforated PVC pipe installed in absorption trenches. In areas having unusual soil or water characteristics, local experience should be reviewed before selecting the

distribution piping materials. The individual laterals should not be over 100 ft (30 m) long, and the trench bottom and title distributing piping should be level. Use of more and shorter laterals is preferred because if something should happen to disturb one line, most of the field will still be serviceable. Many different types of engineering designs may be used in laying out the subsurface disposal fields. Typical layouts of absorption trenches are shown in Figs. 9.15 and 9.16, and a cross-section is illustrated in Fig. 9.17.

In considering the depth of the absorption field trenches, it is possible for the tile lines to freeze during a prolonged cold period. Freezing rarely occurs in a carefully constructed system kept in continuous operation. It is important during construction of the system to assure that the tile lines are surrounded by gravel.

The required absorption area of a trench is considered the bottom area only. These figures include a statistical allowance for absorption by the sidewall area of the trench. Trenches shall be designed for two conditions. One is for private dwellings and the second is for other types of facilities. Both are based on the results of the soil percolation test and the flow into the leaching field from bedrooms or people. The area requirements per bedroom shall be obtained from Table 9.13. The quantity of sewage from other sources shall be obtained from Table 6.25.

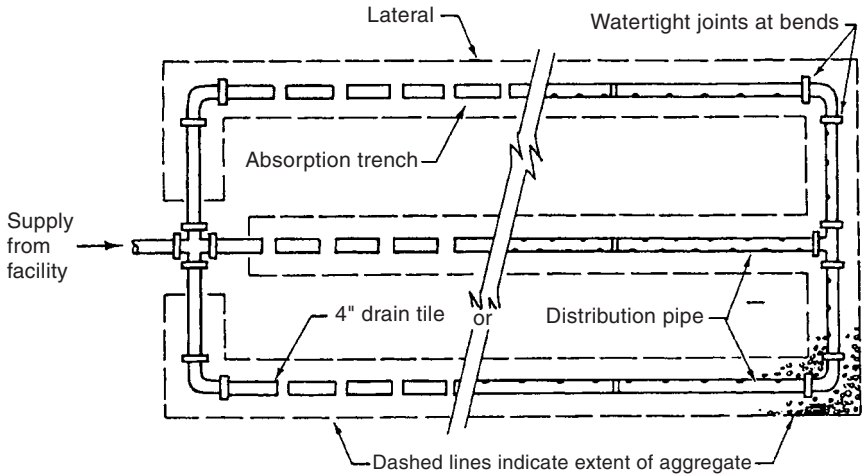

FIGURE 9.15 Distribution piping connected by a cross fitting.

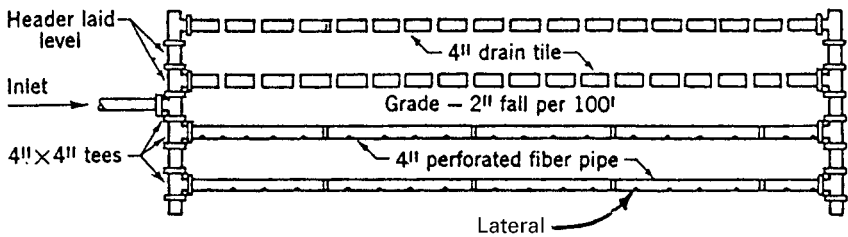

FIGURE 9.16 Distribution piping connected by a header.

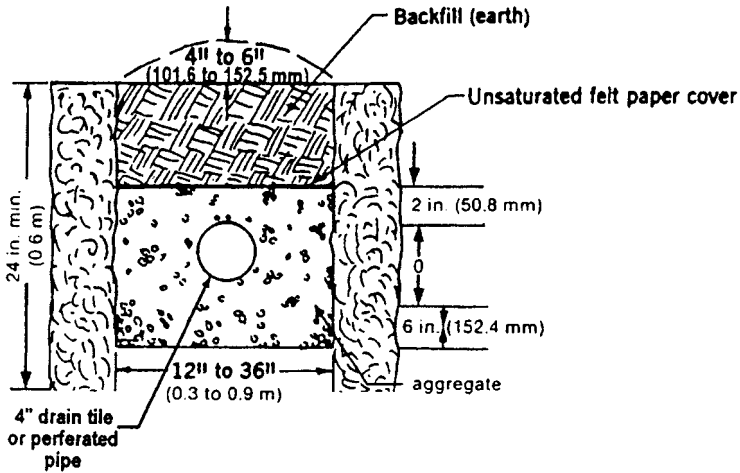

FIGURE 9.17 Cross section through typical absorption trench.

**Trench Installation.** The pipe trench shall be of sufficient width and depth and surrounded by clean, graded gravel. In order to provide the minimum required gravel depth and earth cover, the depth to the bottom of the absorption trenches should be at least 24 in (0.6 m). Additional depth may be needed for contour adjustment, extra aggregate under the tile or other design purposes. The aggregate may range in size from  $\frac{3}{4}$  to 1.5 in (19.1 to 38.1 mm). Cinders, broken shell and similar materials are not recommended because they are usually too fine and may lead to premature clogging. The material should extend from at least 2 in (50.8 mm) above the top of the pipe to at least 6 in (152.4 mm) below the bottom of the pipe. If tile is used, the upper half of the joint openings should be covered. The top of the gravel should be covered with treated building paper, a 2-in (50.8 mm) layer of hay or straw or a similar material. An impervious covering should not be used because it will interfere with the evapotranspiration at the surface. Although generally not figured in the engineering calculation is, evapotranspiration is often an important factor in the operation of horizontal absorption systems.

The top of a new absorption trench should be hand tamped and with 4 to 6 in (100 to 152 mm) of earth. Unless this is done, the top of the trench may settle to a point lower than the ground. This condition will cause the collection of storm water in the trench, and this can lead to the premature saturation of the absorption field and, possibly, to a complete washout of the trench. Machine tamping or hydraulic back filling of the trench should not be used. Caution shall be used to avoid root intrusion when constructing leaching fields near trees.

**Seepage Beds.** Absorption systems having trenches wider than 3 ft (0.9 m) are called seepage beds. Variations of design practices utilizing an increased width are being used in many areas with the approval of the local administration authority. The design of the trenches is based on an empirical relationship between the percolation test and the bottom area of the trenches.

Studies have demonstrated that a seepage bed is a satisfactory means for the disposal of the effluent in soils that are acceptable for soil absorption systems.

The use of a seepage bed results in the following advantages.

1. Wide seepage beds make more efficient use of the land available for the absorption system than a series of long and narrow trenches (with wasted land between these trenches).

2. Efficient use may be made by a variety of earth moving equipment employed at projects for other purposes, such as basement excavation and landscaping, resulting in savings on the cost of the system.

Design of the seepage bed shall consider the following:

1. The amount of the bottom absorption area required should be the same as that recommended in Table 9.12.
2. The seepage bed should have a minimum depth of 24 in (0.6 m) below the natural ground level in order to provide for a minimum earth back fill cover of 12 in (0.3 m).
3. The seepage bed should have a minimum depth of 12 in (0.3 m) of rockfall or packing material extending at least 2 in (50 mm) above and 6 in (150 mm) below the distribution pipe.
4. The bottom of the seepage bed and distribution tile (or perforated pipe) should be level.
5. The lines for distributing the effluent should be spaced less than 6 ft (1.8 m) apart and less than 3 ft (0.9 m) from the seepage bed sidewall.
6. When more than one seepage bed is used, there should be a minimum of 6 ft (1.8 m) of undisturbed earth between the adjacent seepage beds, and the seepage beds should be connected in series.

**Seepage Pits.** A seepage pit is a pit that receives the discharge of a septic tank and is commonly used either to supplement the subsurface disposal system or in lieu of a system where the conditions favor their operation. It is constructed with an open bottom and sides of perforated concrete, brick or other material that allows effluent to percolate out into the surrounding soil. It is sized using Table 9.12 to determine the required square ft ( $m^2$ ) area required and Table 9.13 to determine the size of the pit.

A cesspool is a pit that receives raw sewage from a facility that allows effluent to percolate out into the surrounding soil. It is constructed in a similar manner as a seepage pit. A cesspool is generally not permitted to be used.

### Distribution Boxes

Distribution boxes are not recommended and are harmful to the systems for the following reasons:

1. Data indicates that, on level ground, equal distribution is not necessary if the system is designed so that an overloaded trench can drain back to the other trenches before a failure occurs.
2. On sloping ground, a method of distributions is needed to prevent an excessive build-up of head and the failure of any one trench before the capacity of the entire system is reached. It is doubtful that distribution boxes can provide an equal distribution.

**TABLE 9.12** Allowable Area for Absorption Trenches

Percolation rate (time in min for water to fall 1 in. [25.4 mm])	Maximum rate of sewage application for absorption trenches, <sup>a</sup> seepage beds, and seepage pits <sup>b</sup> , g/ft <sup>2</sup> /d (L/m <sup>2</sup> /d) <sup>c</sup>	Percolation rate (time in min for water to fall 1 in. [25.4 mm])	Maximum rate of sewage application for absorption trenches, <sup>a</sup> seepage beds, and seepage pits <sup>b</sup> , g/ft <sup>2</sup> /d (L/m <sup>2</sup> /d) <sup>c</sup>
1 or less	5.0 (244.3)	10	1.6 (78.2)
2	3.5 (171.0)	15	1.3 (63.5)
3	2.9 (141.7)	30 <sup>d</sup>	0.9 (44.0)
4	2.5 (122.2)	45 <sup>d</sup>	0.8 (39.1)
5	2.2 (107.5)	60 <sup>d,e</sup>	0.6 (29.3)

<sup>a</sup> Absorption area is figured as trench bottom area and includes a statistical allowance for vertical sidewall area.

<sup>b</sup> Absorption area for seepage pits is effective sidewall area.

<sup>c</sup> Not including effluents from septic tanks that receive wastes from garbage grinders and automatic washing machines.

<sup>d</sup> More than 30 is unsuitable for seepage pits.

<sup>e</sup> More than 60 is unsuitable for absorption systems.

**TABLE 9.13** Square Feet Requirements for Seepage Pits

Inside diameter of chamber in feet plus 1 foot for wall thickness plus 1 foot for annual space	Depth in feet of permeable strata below inlet					
	3	4	5	6	7	8
7	47	88	110	132	154	176
8	75	101	126	151	176	201
9	85	113	142	170	198	226
10	94	126	157	188	220	251
11	104	138	173	208	242	277
13	123	163	204	245	286	327

For SI: 1 ft = 304.8 mm, 1 square ft = 0.0929 m<sup>2</sup>.

### Serial Distribution

Serial distribution is achieved by arranging the individual trenches of the absorption system so that each trench is forced to pond to the full depth of the gravel fill before the liquid flows into the succeeding trench. It minimizes the importance of variable absorption rates by forcing each trench to absorb the effluent until its complete capacity is utilized. The variability of the soils, even in the small area of an individual absorption field, raises a doubt about the desirability of uniform distribution.

### Mound Systems

The mound system is used when there is not enough depth of naturally occurring soil over an impermeable formation or where high ground water exists. This usually requires the effluent to be pumped from the septic tank discharge to the soil absorption bed at a higher elevation.

A mound type soil absorption system is a last resort and should be used only when there is not enough naturally occurring soil to provide the required soil absorption bed area on a site. If the mound system can not be installed, the site will often be considered unbuildable. The following parameters should, in general, be considered unsuitable for a mound system:

1. Over an existing, failing soil absorption system
2. Where less than 2 ft (610 mm) of unsaturated soil is available over creviced or porous bedrock
3. Where less than 2 ft (610 mm) of unsaturated soil is available over high ground water
4. Over previously compacted soil
5. A percolation rate of greater than 120 in per min (4.7 mm/min)

Local codes must be used for all design and installation requirements.

## Estimates of Sewage Quantities

Normally, disposal systems are designed prior to the actual construction of a facility. To estimate the quantity of sewage, the first consideration must be given to local code requirements. These requirements usually result in design flows considerably above average.

If there are no code requirements, the most reliable criteria would be readings from water meters at similar existing buildings. This can usually be obtained from the water utility company. It is recommended that a safety factor of 10% be added to the quantity of water obtained to account for any additional unknown requirements.

Where codes and actual usage data are not available, it is necessary to use other methods of estimating the amount of sewage to be discharged. Refer to Table 6.86 for typical waste water flows from commercial, institutional and recreational sources.

## Design Considerations

Some authorities favor placing limits on the size and capacity of septic tank type disposal systems. Under such circumstances it may be desirable to provide separate systems for groups of limited numbers of apartments, mobile homes or other occupancies. Some favor limits approaching (not to exceed) 10 apartments per system. This has the advantage of limiting the number of units affected by temporary system malfunctioning as by overloading due to plumbing fixture malfunctioning (constantly running water closets, for instance).

## ***COLLECTION AND TREATMENT ALTERNATIVES***

---

The use of self contained sewage treatment plants, particularly the tertiary treatment types, has found wide acceptance for facilities. This method is outside the scope of this chapter but is discussed briefly under individual sewage treatment systems.

The alternatives to conventional primary and secondary treatment includes sand filtration and evapotranspiration. Sand filters have been used in sewage treatment for many years. More recently, the standard systems have been modified to recirculating sand filter systems and have proved that, if properly designed, installed and operated, they can produce effluents that will meet stringent effluent and stream quality national standards. Evapotranspiration, as a means of disposing of domestic wastes, has been researched at several locations and its use accepted by various local jurisdictions. However, this system is rarely used.

Alternatives to the typical gravity collection and distribution system that should be evaluated are small diameter gravity sewers, pressure sewers and vacuum sewers. If the septic tank effluents are collected rather than the raw wastes, small-diameter pipe (4-in nominal) may be used to reduce the cost of conventional gravity sewers. Pressure sewer systems generally consist of septic tanks at each facility, a small submersible pump and small diameter plastic mains. Grinder pumps may be used in place of the septic tank. Construction costs are reduced because the sewer main can follow the contour of the land just below the frost line.

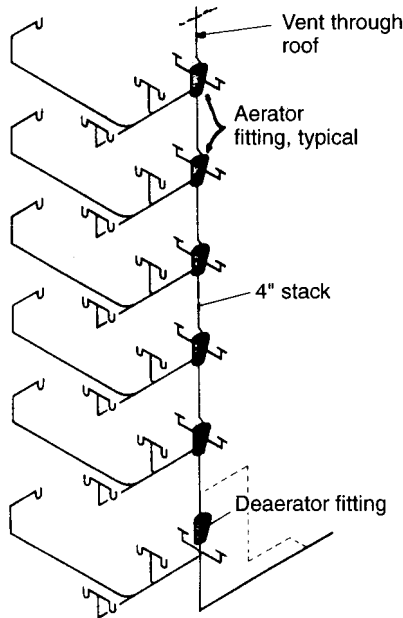

FIGURE 9.18 Sovent system.

## SOVENT PLUMBING SYSTEM

The Sovent drainage system is a patented, combination drainage and vent system that uses a single pipe instead of the conventional two-pipe (vent and drainage) piping. The Sovent system is suited only for multistory buildings. Although widely installed in many countries throughout the world, it has found only limited acceptance in the United States. A typical Sovent stack is illustrated in Fig. 9.18. This system has the potential for substantial cost savings compared to a conventional two-pipe system.

The principal components of the Sovent system are standard pipes used for stacks and branch piping, aerator fittings used at the branch connection to a stack on each floor, and a deaerator fitting installed at the base of the stack before connecting to the house's drain.

The Sovent system shall conform to ANSI B-16.45 and CISMA Standard 177.

# SANITARY VENT

## **SYSTEM DESCRIPTION**

---

The sanitary vent system is a network of pipes terminating in the atmosphere and directly connected to the sanitary drainage piping system for the purpose of limiting air pressure fluctuations within the sanitary drainage piping to  $\pm 1$  in of water column. There are two main reasons why the vent system is an integral and necessary adjunct to any drainage piping network:

1. It prevents the loss of fixture trap seals.
2. It permits the smooth flow of water in the drainage system.

Less important problems caused by excessive air pressure in the drainage system will also be prevented by vents:

1. Unsightly movement of water levels in water closet bowls
2. The possibility of sewer gases discharging through a fixture trap
3. Noise in the drainage system due to the “gurgling” of water

Most problems that do not result from blockages in the drainage system are caused by fluctuations in air pressure. These problems can be either eliminated or reduced to a level where they are no longer objectionable by designing a vent system that limits air pressure variations in the drainage piping network to a generally accepted figure of  $\pm 1$  in of water column. This basic design criteria have been used to determine the vent sizing and allowable lengths that appear in modern codes.

## **NOMENCLATURE**

---

Definitions are given in the glossary. Since it is possible that there are differences in terminology between some definitions used in this book and those appearing in local, regional, or national codes, it is necessary to check the codes to ensure a full understanding of all the components of the system.

## **SYSTEM DESIGN**

---

### **General System Design Considerations**

Differences in pressure within drainage piping are caused by the flow of water. When water is flowing under design conditions in a horizontal drain (approximately one-half full), the air above the liquid will be forced into movement by the friction between the flowing water and the air. In a stack, the water flows around the perimeter of the pipe leaving a central core of air except when overloaded.

The following principles govern the design of the vent system.

1. When design flow in the sanitary system is exceeded, the pipes are completely filled with water, forming a solid slug of water that compresses the air ahead of, and creates a vacuum behind, the slug.

2. The air moving in a vent pipe has friction losses similar to those of flowing water. Thus, the longer the pipe, the larger the diameter.

3. The amount of air displaced is proportional to the amount of water flowing in the drainage pipe. The flow is determined by using drainage fixture units (DFUs).

4. The size of a vent stack should be a minimum of one-half the size of a drainage stack. The size of a branch vent should be a minimum of one-half the size of the branch drainage line it serves.

5. The charts appearing in plumbing codes often contain a heading for soil or waste size that refers to "stack size." This heading should also be used for horizontal branch soil and waste stacks. Since the venting requirements for a stack are more severe than those for a horizontal drainage line, a small safety factor is required.

6. All fixture vents must rise above the flood level of the fixture served in order not to act as waste lines in the event the drain line becomes blocked.

### Developed Length Measurement

The developed length of an individual or common vent is measured from its connection with the fixture trap arm to the connection with the branch vent or vent stack. The developed length of a branch vent is taken from the farthest connection with a waste branch from the point being sized. The developed length of a vent stack is taken from its connection with the soil or waste stack to its terminal above the roof.

### Sizing Vent Stacks, Vent Branches, and Fixture Vents

Plumbing codes contain the information necessary to size the vent system. A typical vent-sizing chart is presented in Table 9.14.

In order to enter Table 9.14, there are three items that must be known: (1) the total DFU count of the soil or waste line associated with the vent being sized, (2) the developed length of the vent being sized, and (3) the size of the soil or waste branch or stack.

Having calculated these items, enter the table with the most severe condition of soil pipe size or DFUs. Then read horizontally across to the figure that meets or exceeds the calculated developed length. Read up to find the correct size of the vent. Use the following as a guide to sizing:

1. For vent stacks, use the total DFU load for the drainage stack and the full developed length of the vent to find the size. Vent stacks must be undiminished in size for their entire length.
2. For branch vents, use the longest developed length from the point where the size is being determined to the farthest connection to the waste line.

**TABLE 9.14** Size and Length of Vents

Size of soil or waste stack, in†	Fixture units connected	Diameter of vent required, in*										
		1¼	1½	2	2½	3	4	5	6	8		
		Maximum length of vent, ft‡										
1½	8	50	150									
2	12	30	75	200								
2	20	26	50	150								
2½	42		30	100	300							
3	10		30	100	100	600						
3	30			60	200	500						
3	60			50	80	400						
4	100			35	100	260	1000					
4	200			30	90	250	900					
4	500			20	70	180	700					
5	200				35	80	350	1000				
5	500				30	70	300	900				
5	1100				20	50	200	700				
6	350				25	50	200	400	1300			
6	620				15	30	125	300	1100			
6	960					24	100	250	1000			
6	1900					20	70	200	700			
8	600						50	150	500	1300		
8	1400						40	100	400	1200		
8	2200						30	80	350	1100		
8	3600						25	60	250	800		
10	1000							75	125	1000		
10	2500							50	100	500		
10	3800							30	80	350		
10	5600							25	60	250		

\* See Table 2.9.

† See Table 9.1.

‡ 1 ft = 0.3 m.

3. For individual fixture vent size, refer to Table 9.1.
4. For building trap vents and fresh air inlets, the size should be half the size of the building drain, with a minimum size of 4 in (DN 100).

### Vent Terminals

The vent pipe passing through the roof must remain open under all circumstances. The two conditions that would cause the exposed pipe to become blocked are frost closure and snow closure. Local codes and authorities should provide the minimum extension to avoid closure by accumulated snow on a roof.

In the absence of specific code requirements, the following could be used as a guide to locate vent extensions. The vent extension shall not be located under or within 10 ft of any window, door, or ventilating opening unless it is 2 ft (0.6 m) above the opening. If the terminal is through a building wall, it shall be located a

minimum of 10 ft (3 m) from the property line, a minimum of 10 ft (3 m) above grade, and not under any overhang.

### Relief Vents

Soil or waste stacks with no offsets in buildings having more than 10 branch intervals shall be provided with a relief vent at each 10th interval starting at the top floor. Offsets in the drainage stacks may also be required to have relief vents.

There are several acceptable configurations allowed by various codes. In general, the lower end of the relief vent shall connect to the soil or waste stack below the horizontal branch serving the floor required to have the relief vent. The upper end of the relief vent shall connect to the vent stack no less than 3 ft (1 m) above that same floor level. The size shall be equal to that of the vent stack to which it is connected or the drainage stack, whichever is smaller.

### CIRCUIT AND LOOP VENTS

These venting schemes are intended to provide a more economical means of venting than using individual vents. They are allowed only for venting floor-mounted fixtures such as water closets, shower stalls, and floor drains and may not be acceptable in all code jurisdictions.

Circuit venting (Fig. 9.19) requires a uniformly sized drainage line with at least two, but no more than eight, fixtures connected in a battery arrangement. The circuit vent is connected on one end to the horizontal drain line between the two most

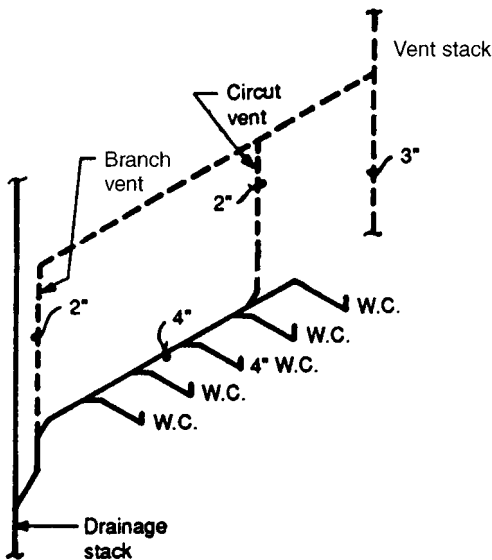

FIGURE 9.19 Detail of circuit vent.

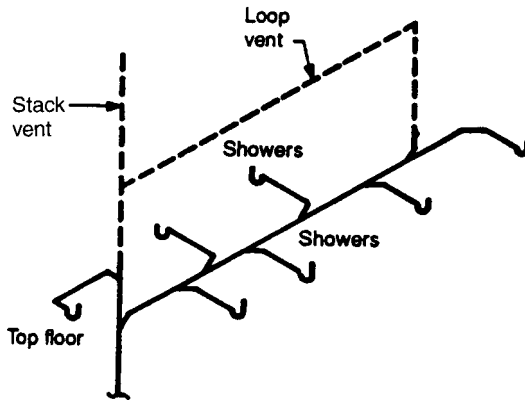

FIGURE 9.20 Detail of loop vent.

remote fixtures and is connected on the other end to the vent stack. In addition to the circuit vent, a relief vent is required to be connected to the horizontal drain line at the end of the battery, or every eight fixtures. The sizes of each shall be one-half the size of the horizontal drainage line or the full size of the vent stack, whichever is smaller.

Loop venting (Fig. 9.20) is the same as circuit venting except for the connection of the branch vent to the building system. This type of vent loops back to the stack vent instead of the vent stack.

## **WET VENTS**

---

A wet vent is a combined vent/drain line that receives drainage from fixtures in addition to serving as a vent pipe. Wet vents are primarily used in residential projects, and permitted only by a limited number of codes. Wet vents must conform to the guidelines provided in each application code.

## **SUDS RELIEF VENTS**

---

Suds pressure zones are illustrated in Fig. 9.9. If a drainage connection to these zones is made, a relief vent must be installed from the base of the suds pressure zone of the drainage stack to a nonpressure zone. The sizes of typical suds pressure relief vents are shown in Table 9.15.

## **SUMP AND EJECTOR VENTS**

---

All codes require the venting of ejector pits, since they are gasketed and airtight. Many codes may also require the venting of sump pits. The vent pipe size is

**TABLE 9.15** Suds Pressure Relief Vent Size

Waste size, in*	Relief vent size, in*
12	2
2½	2
3	2
4	2
5	3
6	4
8	5
	6

\* See Table 2.9.

determined from the gpm discharge of the pump and the developed length from the pit to its connection with the building vent system or vent terminal. Table 9.16 is a typical guide to sizing such vents.

## VENT HEADERS

When combining several vent stacks into a common header at the highest level to penetrate the roof only once, various codes require that the combined vent pipe be

**TABLE 9.16** Size and Length\* of Sump and Ejector Vents

Discharge capacity of sump pump, gpm <sup>b</sup>	Diameter of vent, inches <sup>a</sup>					
	¼	½	2	2½	3	4
	(Maximum equivalent length of vent, ft, given below) <sup>c</sup>					
10	N.L.†	N.L.	N.L.	N.L.	N.L.	N.L.
20	270	N.L.	N.L.	N.L.	N.L.	N.L.
40	72	160	N.L.	N.L.	N.L.	N.L.
60	31	75	270	N.L.	N.L.	N.L.
80	16	41	150	380	N.L.	N.L.
100	10‡	25	97	250	N.L.	N.L.
150	NP§	10‡	44	110	370	N.L.
200	NP	Np	20	60	210	N.L.
250	NP	NP	10	36	132	N.L.
300	NP	NP	10‡	22	88	380
400	NP	NP	NP	10‡	44	210
500	NP	NP	NP	NP	24	130

<sup>a</sup> See Table 2.9.<sup>b</sup> 1 gpm = 3.8 L.<sup>c</sup> 1 ft = 0.3 m.

\* Developed length plus an appropriate allowance for effects of entrance losses and friction due to fittings, changes in direction, and changes in diameter. Suggested allowances may be obtained from NBS Monograph 31 or other acceptable sources. An allowance of 50% of the developed length may be assumed if a more precise value is not available.

† No limit; actual values greater than 500 ft.

‡ Less than 10 ft.

§ Not permitted.

**TABLE 9.17** Cross-Section Area of Pipe

Pipe size, in*	Area, in <sup>2</sup> †
1½	1.767
2	3.1416
2½	4.908
3	7.068
4	12.566
5	19.635
6	28.274

\* See Table 2.9.

† 1 in<sup>2</sup> = 6.5 mm<sup>2</sup>.

sized using the total number of DFUs of all the connected vents and the single longest developed length of all the vent stacks being combined. Other codes require that the combined vent stacks have a minimum cross-section area of all the separate vent pipes being combined. Table 9.17 lists the cross-section areas for pipes in square inches.

# INTERIOR STORM WATER DRAINAGE

## **SYSTEM DESCRIPTION**

---

This section describes the interior storm water drainage system that collects storm water runoff from building roofs and smaller ancillary areas exposed to the weather and conveys the runoff to an approved point of disposal. Ancillary areas of a building include areaways, walkways, canopies, and balconies.

Drainage from parking lots, roadways, and other larger areas of the site are discussed in Chap. 6, in the section entitled Surface Drainage.

## **GENERAL SYSTEM CRITERIA**

---

### **General**

The design of the storm water drainage system requires that the following information be obtained in order to establish design criteria.

1. Local climatic conditions
2. Local building and plumbing code restrictions
3. Building use
4. Roof pitch
5. Location, size, depth, type, and availability of the ultimate point of disposal
6. Total size of roof and other areas contributing to the storm water flow
7. Method of disposal or connection to public sewers. It is common practice for authorities concerned with storm water disposal to have a storm water management program to restrict the inflow of storm water to a predetermined value. This requires that storm water be retained somewhere on site. Refer to Chap. 6, section entitled Storm Water Retention Methods, for criteria.
8. Allowable methods of disposal and necessary permits required if public sewers are not available
9. Facility standards and preferences
10. For industrial sites, discharge of untreated storm water subject to contamination is prohibited. This could result from process equipment located on roofs. Refer to Chap. 6 for additional discussion.

## **ROOF DRAINAGE SYSTEMS**

---

There are two types of systems used to remove storm water runoff, conventional and limited discharge. The conventional system removes runoff as quickly as it accumulates. The limited discharge system removes only a portion of the runoff, storing the remainder temporarily on the roof. Selection of the appropriate method

depends on capacity and/or availability of disposal facilities and acceptance of the method by local codes and authorities.

### Roof Drains

Roof drains allow rainwater to enter the drainage system after falling on a roof. Drains shall have a dome that extends above the roof level in order to allow water to enter the drain even if partially blocked by debris. It is good practice to install two drains in every area of a roof to allow drainage if one drain is completely blocked. Domes are manufactured in a variety of materials, with PP often selected. They shall have a free area 150 percent of the area of the drain discharge pipe. Domes on roof drains selected for limited discharge systems have a restriction that limits the amount of storm water entering the drain.

Drain bodies are available to match any roof construction and must be selected to specifically match that construction.

### Overflows and Secondary Storm Drainage Systems

If roof water retention is not a design feature, a fail-safe method must be provided to remove excess runoff from a roof before the water level rises to a point where damage would result. *Scuppers* are commonly used to allow the excess runoff to discharge directly off the roof and down the side of the building. Codes often stipulate how high above the roof level scuppers must be installed. One disadvantage of scuppers is that wave action may allow water to spill out of the scuppers before the design depth is reached. The discharge from rectangular scuppers is given in Table 9.18.

Various codes mandate the use of a completely separate and independent overflow piping network complete with roof drains in addition to the regular storm water drainage system. This network could connect either to the regular system independently outside a building or directly to the point of disposal, depending on

**TABLE 9.18** Discharge from Rectangular Scuppers—Gallons per Minute

Water head (inches)	Width of scupper—(inches)					
	6	12	18	24	30	36
0.5	6	13	19	25	32	38
1	17	35	53	71	89	107
1.5	31	64	97	130	163	196
2		98	149	200	251	302
2.5		136	207	278	349	420
3		177	271	364	458	551
3.5			339	457	575	693
4			412	556	700	844

**NOTES:**

Table 9.18 is based on discharge over a rectangular weir with end contractions.

Head is depth of water above bottom of scupper opening.

Height of scupper opening should be 2 times the design head.

Coordinate the allowable head of water with the structural design of the roof.

code requirements. Another type of overflow protection is the use of separate overflow pipes or drains, in addition to the regular drains, connecting to the regular storm water drainage piping. Local codes and authorities often have preferences and should provide the preferred method for design. No additional roof area is required for a secondary drain.

### Sidewall Area Calculation

Precipitation falling on vertical walls of structures located on roofs and other areas, such as penthouse walls and stair towers, will add to the runoff calculated for horizontal area only. It is necessary for these vertical areas to be included into the horizontal tributary area. To calculate the amount of sidewall area that shall be added to the horizontal roof segment, determine the square foot area of the single or two largest adjacent walls that would contribute runoff to any one roof drain. Then divide this area in half, because a smaller amount of rain falls on a vertical surface than on a horizontal surface. Add this vertical sidewall area to the horizontal tributary area for each roof drain to obtain the total tributary area.

### Roof Drainage Design Procedures

**Conventional Small Roof Drainage Systems.** The “small” roof is one with a roof area less than the maximum square foot area appearing in the tables associated with the plumbing code used for the project. Larger roof areas are discussed later in this chapter. Design of a conventional roof drainage system consists of the following general steps:

1. Locate drains on roofs and ancillary areas throughout all areas of the project discharging into the system.
2. Determine the code-mandated overflow system requirements.
3. Route the storm water and overflow system piping and set pitch of pipe.
4. Size the piping network by first calculating the total tributary area for each individual drain located in each specific section of the roof and other areas. For horizontal pipe, the sizing procedure starts at the most remote part of the system, using the pipe pitch and total tributary area for each horizontal pipe section from design point to design point.
5. Storm water piping is sized using the total square feet of roof area at each design point and the pitch of the drainage pipe. Two different styles of tables are in general use by model codes. One style uses a single rainfall rate that is incorporated into the code charts along with the maximum allowable tributary area and various pitches of pipe. No further calculations are required. A second uses multiple rainfall rates with the maximum allowable tributary area and various pitches of pipe.
6. Enter the chart using a single rainfall rate with the pitch and total tributary area. For horizontal pipe, start from the most remote part of the system. Determine the pipe pitch and total tributary area for each horizontal pipe section from design point to design point. Select the figure at the intersection of the criteria used for that specific chart and choose a pipe size corresponding to a figure equal to or greater than the calculated tributary area. (Notes associated with different chart types allow conversion to another rainfall rate if different from that of the chart.)

**TABLE 9.19** Size of Horizontal Storm Drains,\* Single Rainfall Rate

Diameter of drain.		Maximum projected area for drains of various slopes†					
		1/8-in slope		1/4-in slope		1/2-in slope	
		in	DN	ft <sup>2</sup>	gpm‡	ft <sup>2</sup>	gpm
3	80	822	34	1,160	48	1,644	68
4	100	1,880	78	2,650	110	3,760	156
5	125	3,340	139	4,720	196	6,680	278
6	150	5,350	222	7,550	314	10,700	445
8	200	11,500	478	16,300	677	23,000	956
10	250	20,700	860	29,200	1,214	41,400	1,721
12	300	33,300	1,384	47,000	1,953	66,600	2,768
15	375	59,500	2,473	84,000	3,491	119,000	4,946

\*Based upon a maximum rate of rainfall of 4 in/h. Where maximum rates are more or less than 4 inches per hour, the figures for drainage area shall be adjusted by multiplying by 4 and dividing by the local rate in inches per hour.

† 1 ft<sup>2</sup> = 0.093 m<sup>2</sup>.

‡ 1 gpm = 3.8 L.

For vertical piping, use the tributary area discharging into the vertical leader, increasing the size as additional areas are added. Table 9.19 is a typical table used to size the horizontal drainage pipe based upon pitch of the pipe and tributary area. Table 9.20 is a typical table used to size the roof drain itself and the vertical pipe stack using the tributary area. Table 9.21 allows the sizing of gutters. These tables are reproduced from the Uniform Plumbing Code, which uses 4 in/h as the basis for the tables. Rates required by local authorities shall always take precedence over a regional or model code rainfall rate.

7. The second style of code has been developed for model codes using multiple rainfall rates. These charts are very similar to the regional ones except for the addition of multiple rainfall rates. A typical chart is shown in Table 9.22. Enter the chart using the selected rainfall rate, the pitch of the pipe and total tributary area. Select the figure at the intersection of the criteria used and choose a pipe size corresponding to a figure equal to or greater than the calculated tributary area. The rainfall rate selected is the rainfall rate used for the main site or a 10-year, 10-min storm.

8. In some areas of the country, the public sewer is a combined sanitary and storm water system. The sanitary and storm water systems can be combined either inside or outside the building wall. Good engineering practice has them leave the building separately and combined outside the building wall. The combined system is usually sized on the basis of DFUs. In order to size the combined system, the square feet of tributary area of the storm water system is converted to DFUs. To calculate the size of the combined building drainage network, use Table 9.23 as a guide for the conversion of square feet into DFUs. When a pump discharges into the storm water system, refer to Table 9.24 for the square ft equivalent for 1 gpm of pump discharge.

### *Conventional Large Roof Drainage Systems*

1. When a very large building, such as a warehouse or factory, has a total square foot tributary area in excess of those appearing in the code sizing tables, another

**TABLE 9.20** Size of Vertical Conductors and Leaders\*

Diameter of leader or conductor, †		Maximum projected roof area	
DN	in	ft <sup>2</sup>	gpm
50	2	544	23
65	2½	987	41
80	3	1,610	67
100	4	3,460	144
125	5	6,280	261
150	6	10,200	424
200	8	22,000	913

\*Based upon a maximum rate of rainfall of 4 inches per hour and on the hydraulic capacities of vertical circular pipes flowing between one-third and one-half full at terminal velocity, computed by the method of NBS Mono. 31. Where maximum rates are more or less than 4 inches per hour, the figures for drainage area shall be adjusted by multiplying by 4 and dividing by the local rate in inches per hour.

†The area of rectangular leaders shall be equivalent to that of the circular leader or conductor required. The ratio of width to depth of rectangular leaders shall not exceed 3 to 1.

**TABLE 9.21** Size of Roof Gutters

Based on 4 in/h (100 mm/h) rainfall

Diameter of gutter,*		Maximum projected roof area for gutters, ft <sup>2</sup>			
		¼ in (.5 cm/m)	⅜ in (1.0 cm/m)	½ in (2.0 cm/m)	¾ in (4.0 cm/m) & vertical
IN	DN				
3	80	170	240	340	480
4	100	360	510	720	1,020
5	125	625	880	1,250	1,770
6	150	960	1,360	1,950	2,770
7	175	1,380	1,920	2,760	3,900
8	200	1,990	2,800	3,980	5,600
10	250	3,600	5,100	7,200	10,000

\*Gutters other than semicircular may be used provided they have an equivalent cross-sectional area.

Source: *Uniform Plumbing Code*.

**TABLE 9.22** Size of Horizontal and Vertical Storm Drains, Multiple Rainfall Rate

DN	Size of pipe, in; 1/8-in slope	Maximum rainfall, inches (mm) per hour				
		2 (51)	3 (76)	4 (101)	5 (127)	6 (152)
80	3	1,644	1,096	822	657	548
100	4	3,760	2,506	1,880	1,504	1,253
125	5	6,680	4,453	3,340	2,672	2,227
150	6	10,700	7,133	5,350	4,280	3,566
200	8	23,000	15,330	11,500	9,200	7,600
250	10	41,400	27,600	20,700	16,580	13,800
300	12	66,600	44,400	33,300	26,550	22,200
375	15	109,000	72,800	59,500	47,600	39,650

DN	Size of pipe, in; 1/4-in slope	Maximum rainfall, inches (mm) per hour				
		2	3	4	5	6
80	3	2,320	1,546	1,160	928	773
100	4	5,300	3,533	2,650	2,120	1,766
125	5	9,440	6,293	4,720	3,776	3,146
150	6	15,100	10,066	7,550	6,040	5,033
200	8	32,600	21,733	16,300	13,040	10,866
250	10	58,400	38,950	29,200	23,350	19,450
300	12	94,000	62,600	47,000	37,600	31,350
375	15	168,000	112,000	84,000	67,250	56,000

DN	Size of pipe, in; 1/2-in slope	Maximum rainfall, inches (mm) per hour				
		2	3	4	5	6
80	3	3,288	2,295	1,644	1,310	1,096
100	4	7,520	5,010	3,760	3,010	2,500
125	5	13,360	8,900	6,680	5,320	4,450
150	6	21,400	13,700	10,700	8,580	7,140
200	8	46,000	30,650	23,000	18,400	15,320
250	10	82,800	55,200	41,400	33,150	27,600
300	12	113,200	88,800	66,600	53,200	44,400
375	15	238,000	158,800	119,000	95,300	79,250

Vertical leaders

DN	Diameter of leader, in	Normal rate of rainfall, in (mm) per hour					
		Roof area, ft <sup>2</sup>					
		2	3	4	5	6	8
80	2	1440	960	720	576	480	260
100	2½	2000	1733	1300	1040	865	650
125	3	4400	2933	2200	1760	1470	1100
150	4	9200	6133	4000	3680	3070	2300
200	5	—	—	8650	6920	5765	4325
250	6	—	—	—	—	9000	6750

**Source:** *Uniform Plumbing Code.*1 ft<sup>2</sup> = 0.093 m<sup>2</sup>.

**TABLE 9.23** DFU-Square Foot Equivalents

Drainage area, ft <sup>2</sup> *	Fixture unit equivalent
180	6
260	10
400	20
490	30
1,000	105
2,000	271
3,000	437
4,000	604
5,000	771
7,500	1,188
10,000	1,500
15,000	2,500
20,000	3,500
28,000	5,500
Each additional 3 ft <sup>2</sup>	1 fixture unit

\* 1 gpm = 19 ft<sup>2</sup>.

1 ft<sup>2</sup> = 0.093 m<sup>2</sup>.

**TABLE 9.24** Square ft Equivalent Values for Continuous Flow into a Combined Storm Sewer

Where there is a continuous or semicontinuous discharge into the building storm drain or building storm sewer, as from a pump, ejector, air-conditioning plant, or similar device, each gallon per minute of discharge shall be computed as being equivalent to the square feet or roof area, based upon a rate of rainfall in inches per hour according to the following table:

Rate of Rainfall	Equivalent for one gpm roof area, sq ft
2	48
3	32
4	24
5	19
6	16
7	13
8	12

method must be used to calculate the volume of runoff and size the pipe. This is done by using the actual flow rate rather than square feet of tributary area.

2. The most widely accepted method for the calculation of runoff is the Rational Method, repeated here for convenience. Refer to Chap. 6 for further discussion.

$$Q = A \times I \times R \quad (9.1)$$

where  $Q$  = quantity (flow rate) of storm water runoff, in cubic feet per second (cfs). 1 cfs = 448 gpm (1702 L/m).

$A$  = tributary area in acres. 1 acre = 43,560 ft<sup>2</sup> (4051 m<sup>2</sup>).

$I$  = imperviousness factor. Use a value of 1.0 for roofs.

$R$  = rate (intensity) of rainfall, in inches per hour (in/h). When large roofs are encountered, the intensity requires judgment on the part of the design engineer. The following should be considered:

- a. If the building is part of a larger site, the criteria shall be the same as those used for the site as a whole.
- b. Generally accepted practice uses a 10-year return frequency for the design of roofs. Longer periods are not justified unless a greater degree of protection is desired.
- c. When used for roof design, a 5-min duration is recommended. Some codes allow longer durations, producing less runoff. The decision depends on the degree of protection desired.
- d. With the duration and frequency established, use Fig 6.15 to select an intensity.
- e. Snowmelt should be considered only under very unusual circumstances. Snowmelt is greatest if a severe rainstorm occurs when there is snow on the roof. Tests have shown that a maximum figure of 0.2 in/h (0.2 mm/h) should be added to the intensity, with a figure of 0.1 in/h (0.1 mm/h) acceptable for most storms.

The design procedure is the same as that described for a conventional drainage system. Use Table 9.19 to find the pipe size up to the largest areas in the chart. When those are exceeded, use Eq. (9.1) to calculate the flow rate in gpm of the system at each design point. Determine the slope of the pipe. Use Fig. 6.17 to find the pipe size by connecting the slope and flow rate with a straight line and read the size on the chart where it intersects the pipe size line.

**Limited Discharge Roof Drainage Systems.** There are two reasons to select a limited discharge roof drainage system: for economic reasons or where authorities mandated restricting discharge. The voluntary use of the limited discharge system for economic reasons will allow smaller piping throughout the entire network, resulting in a savings on the total installed cost of the piping.

The use of a mandated limited discharge system may be required where a storm water management program is in force. Areas may have overloaded sewers, allowing only a small portion of the runoff to be discharge into the public sewer. In suburban areas, if discharge into a small stream is proposed, the fact that new roofed areas produce a much greater runoff than former woodland must be considered, since the downstream portion of the stream could become flooded if the full amount of runoff discharged instantaneously into the stream. One of several options is the temporary storage of water on a roof. Other methods of storm water retention are discussed in Chap. 6.

In order to limit the discharge, roof drains are provided with factory preset grate openings that allow only a smaller, predetermined flow of storm water to enter the drain. The allowable amount to be discharged must be given to the manufacturer in order to be set correctly at the factory. The runoff not discharged must be temporarily stored on the roof.

A simplified design procedure for a limited discharge roof drainage system consists of the following general steps:

1. Determine if the code and local authorities will permit limited discharge roof drainage for the project.
2. Since the roof will have to be waterproof and need high curbs built around all openings, there is usually considerable opposition to the storage of water on the roof when based only on economic factors. Past experience has shown that an expensive roof covering is required and the possibility of leakage increases as the roof ages.
3. Establish the maximum allowable flow rate in gpm permitted to discharge into the ultimate point of disposal from all sources of water for the entire site. If the system is voluntary, some iterations will be necessary after the piping is run to find the optimum pipe size compared to the amount of storm water stored on the roof. If discharge is into a sewer, the authorities having jurisdiction will provide the allowable discharge amount. If discharge is into a waterway, the existing site conditions should be calculated. The difference between the existing and proposed discharge volume is the volume of water that should be stored on the roof. If drains in areas other than the roof are present, it is not generally possible to store water from those areas. The discharge from these drains will have to be separated from the total roof discharge to find the actual discharge allowed from the roof alone.
4. Decide on the length of time water will be allowed to remain on the roof. Generally accepted practice is to allow between 12 and 18 h, starting with as short a time as possible. Lengthen the time as necessary to obtain the calculated rate of discharge. Accepted practice is to use a maximum of 24 h.
5. Since the structural engineer must design the roof to support the additional load of stored water, a mutual agreement between the plumbing and structural engineers must be made to determine the depth. If the roof is flat, the generally accepted depth is 3 in. If the roof is pitched, add 3 in of water depth above the high point of the roof. Table 9.25 gives the weight for each inch of water.
6. Find the total amount of rainfall in inches that will fall on the roof for the time established in step 3. This is obtained from Fig. 9.21, which is a 10-year, 24-h rainfall or from Fig. 6.21, which is a 100-year, 24 h rainfall. The 24-h period is used because of its conservative design. A 10 percent reduction in the 24-h figure approximates an 18-h rainfall.
7. Divide the figure found in step 5 with the time found in step 3 (e.g., 8 in divided by 12 h equals 0.67 in/h). Then determine the gpm discharge. Use Table

**TABLE 9.25** Weight of Rainfall

MM	Amount of rain, in	Weight of water, lb/ft <sup>2</sup> *
150	6	31.21
125	5	26.01
100	4	20.81
75	3	15.61
50	2	10.40
25	1	5.20

\* 1 lb = 2.2 kg.

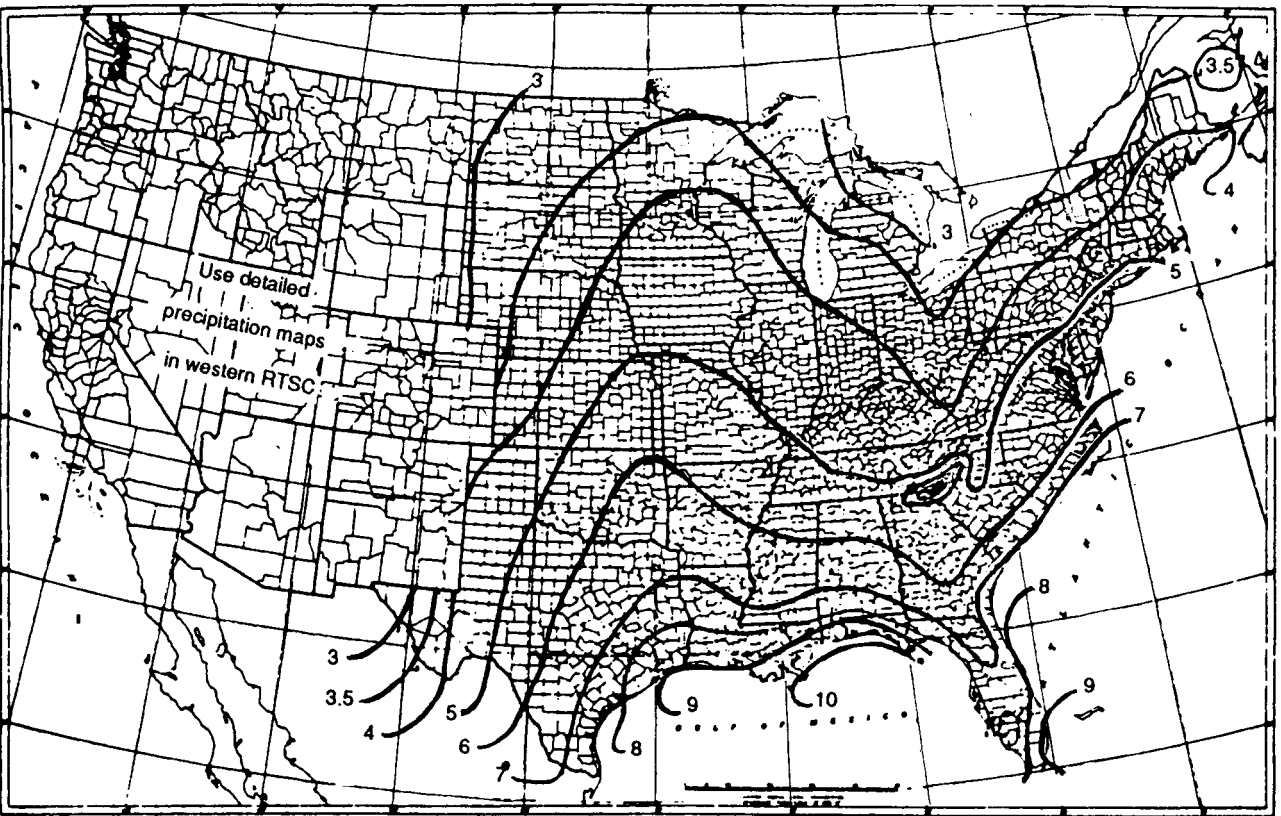

**FIGURE 9.21** 10-Year, 24-hour rainfall. (Adapted from U.S. Weather Bureau map.) In inches (1 in = 25.4 mm).

**TABLE 9.26** Rainfall Conversion Data

Rainfall, in/h <sup>a</sup>	gph per 1 ft <sup>2</sup> †	gpm per 1 ft <sup>2</sup> †
3.0	1.870	0.0312
2.9	1.808	0.0302
2.8	1.745	0.0291
2.7	1.683	0.0281
2.6	1.621	0.0270
2.5	1.558	0.0260
2.4	1.496	0.0250
2.3	1.434	0.0239
2.2	1.371	0.0229
2.1	1.309	0.0218
2.0	1.247	0.0208
1.9	1.184	0.0198
1.8	1.122	0.0187
1.7	1.060	0.0177
1.6	0.997	0.0166
1.5	0.935	0.0156
1.4	0.873	0.0146
1.3	0.810	0.0135
1.2	0.748	0.0125
1.1	0.686	0.0114
1.0	0.623	0.0104

<sup>a</sup>1 in = 25.4 mm.

†1 gal = 3.8 L.

9.26 to convert the rainfall from in/h to gpm (if appropriate). Compare this figure with the maximum allowable discharge from the roof found in step 2. Adjust the retention time as required to match the allowable discharge rate.

**8.** Consideration must be given for a heavy rainfall occurring after the design storm ends, while some water remains on the roof during the draindown time. This rainfall rate should be the actual 1-h duration, with the same return period selected for the project. This 1-h rainfall will deposit a number of inches of rain. The actual drainage rate will be the figure selected in step 2. By subtracting the drainage rate figure (in/h) from the 1-h rainfall figure, the actual total allowable rainfall depth will be found. This depth must not exceed the depth established in step 4. If it does, additional depth of storage is required, or the client must be willing to accept rainwater spilling out of the emergency overflow once during the return period selected, or the additional water will have to be stored on the site.

**9.** Locate drains on roof and find the total number of drains required.

**10.** Route the storm water piping and overflow systems. Set height of overflow drains.

**11.** Divide the number of drains into the amount of total roof discharge allowed to find the gpm flowing out of each drain. Using Table 9.27, size the individual drains, branches, and stacks using the gpm and pitch of the pipe. Limited discharge roof drains are set at the factory for the specified maximum flow rate established by the engineer.

**12.** Size the piping network based on accumulated gpm flow at each design point and the actual pitch of the pipe.

**TABLE 9.27** Drainage Capacity of Piping*Flow capacity for storm water piping systems in gallons per minute, flowing full ( $n = .013$ )*

Pipe diameter, in	DN	Roof drain and vertical downspouts	Horizontal storm drainage			
			cm/m in/ft	Slope		
				1.0 $\frac{1}{8}$	2.0 $\frac{1}{4}$	4.0 $\frac{1}{2}$
2	50	30	—	—	—	
2½	65	54	—	—	—	
3	80	92	36	51	80	
4	100	192	77	110	174	
6	150	563	220	315	449	
8	200	1208	494	696	987	
10	250	2600	943	1302	1800	
12	300	6000	1526	2154	2800	
15	375	—	2873	3500	4950	

1 gpm = 3.8 L/m.

**Conventional Roof Drainage Design Considerations**

1. It is important that the local codes and authorities be consulted for the method used to connect to the public sewers.
2. It is good practice to place two roof drains in any area (except very small areas) to provide at least one open drain if the other becomes blocked by debris.
3. Limit the square footage of any individual roof drain to a maximum of 5000 ft<sup>2</sup> of tributary area.

**Limited Discharge Roof Drainage Design Considerations**

Drains should be no greater than 200 ft (165 m) apart and no greater than 50 ft (15 m) from the end of a tributary area.

**Disposal Methods When There Are No Public Sewers**

In the absence of public sewers, the most common methods of disposal are discharge into nearby watercourses, recharge basins, or drywells.

Discharge into watercourses presents unique problems. Usually, special permits must be obtained and special regulatory requirements followed. Often, oil or other interceptors may be required before the water can be discharged. Since impervious concrete and roof surfaces produce more runoff than the original ground, usually some method of retaining water will be required so the downstream portion of a small stream or creek will not flood during a severe storm. If the watercourse is navigable, permits will be required from the U.S. Army Corps of Engineers and other agencies of the government.

Recharge basins are depressed areas on a site that are normally dry. These basins are sized to collect all the estimated site runoff from a storm of a given duration, usually a 100-year, 24-h storm. Storm water runs into the basin at a high flow rate,

is collected, absorbed into the ground, and evaporates. The size of the recharge basin is determined from a test of the soil's ability to absorb the calculated total volume of runoff plus a safety factor.

Drywells are round or square structures buried in the ground that have openings or porous sides and bottoms. During a rainstorm, the storm water fills the structure, escapes through the openings, and is absorbed into the ground. Local authorities that allow this means of disposal usually mandate the size and number of drywells permitted per square foot of roof area in their specific locality. A typical drywell is illustrated in Fig. 9.22. Other storm water retention methods are discussed in Chap. 6.

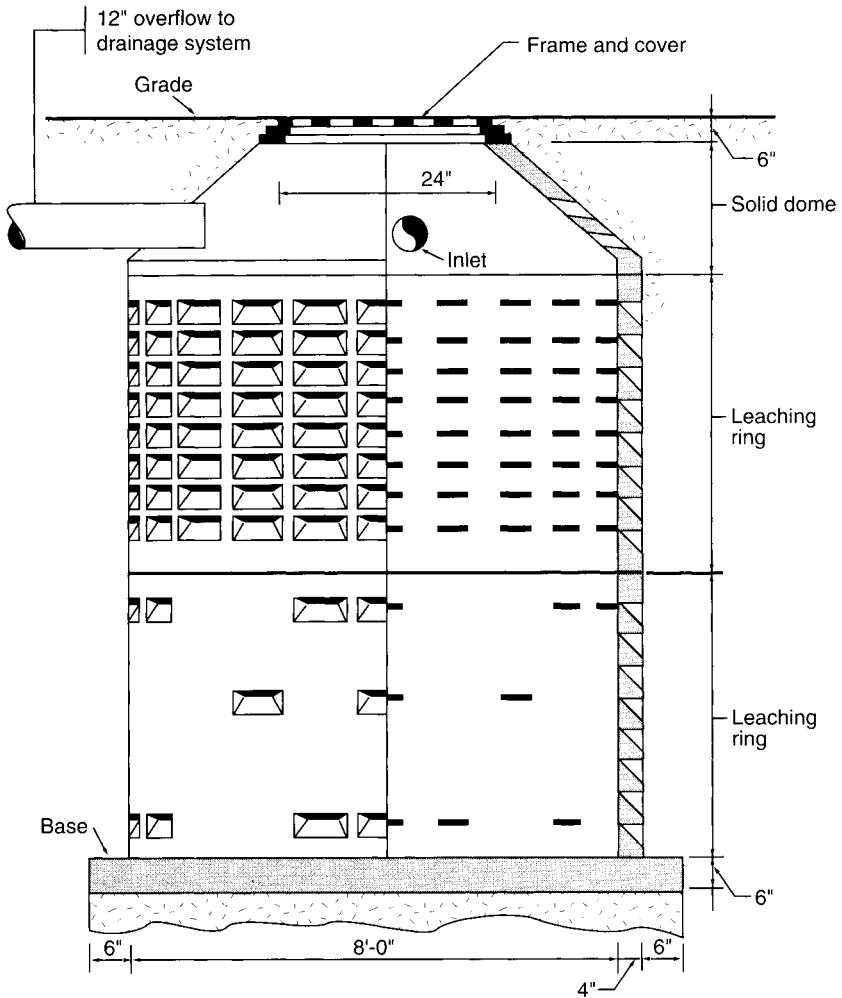

FIGURE 9.22 Detail of typical drywell.

# POTABLE WATER SYSTEMS

## **SYSTEM DESCRIPTION**

---

The potable water system provides hot and cold water that is suitable for human consumption and has adequate purity, pressure, temperature, and volume to satisfy all requirements for a specific project or purpose.

## **WATER TREATMENT**

---

Raw water obtained from wells or other similar sources must be tested and treated, if necessary, to reduce or remove various impurities found in raw water. Specific treatment is based on the volume of water to be treated, type of impurities present and the degree to which various impurities are to be removed. Water treatment methods are discussed in Chap. 4.

## **WATER METERS**

---

When water is provided by a utility company, meters are required for billing purposes. The utility company will usually require a specific location for the meter, such as inside the building or in a pit adjacent to the property or building, clearance around the meter needed for reading the meter, piping arrangement, and other regulations to discourage attempts to bypass the meter.

The water meter is usually a part of a water meter assembly that could include shut-off valves, strainers, a test tee for the local authorities to test the accuracy of the meter, and a meter bypass.

The selection of a meter type, if not mandated by the utility company or local authorities, is based on accuracy and pressure loss through the meter at the intended flow rates. Water meter types include disk meter, turbine meter, and compound meter.

### **Water Meter Types**

The utility company may require the specific make, model, and type, depending on the anticipated usage. A remote-reading type of meter, capable of being read by electronic means at distances away from the meter, may also be required.

In the absence of any regulations, the following is a general guide for selection of a suitable potable water meter.

1. *Disk meter.* Normally ranging in size up to 2 in (DN 50), this type is used for smaller variable flows such as those occurring in residential and small commercial installations.
2. *Compound meter.* Normally ranging in size from 2 to 6 in (DN 50 to 150), this type is used where large volumes and wide variations in flow might be encountered. The initial cost of this meter is high, and it is the largest in physical size.

3. *Turbine meter.* Normally ranging in size from 2 to 10 in (DN 50 to ?), this type is used for variable flow in a narrower range of flow than that of a compound meter.

## CONTAMINATION PREVENTION

Contaminants found in potable water are divided into three general classifications: severe, moderate, and minor. It is necessary to evaluate each facility as a whole and also at specific points of use to protect against potential hazards. Local health, building codes, and ordinances must be consulted for specific requirements and for the suitability of any device for a specific application.

There are five basic methods of preventing the contamination of a potable water system due to cross connections with, and backflow from, a potentially contaminated source:

1. *Air gap.* Suitable for severe hazards, the air gap is passive and is the only fail-safe method of preventing backflow. An air gap is defined as the clear distance between the end of a potable water supply pipe and the highest possible water level from a source of potential contamination. The minimum allowable air gap dimension is provided in local codes, and is usually either 2 in or 2 times the diameter of the supply pipe, whichever is larger. An air gap is illustrated in Fig. 9.23.

2. *Pressure type vacuum breaker.* Suitable for minor hazards, the pressure type vacuum breaker is a mechanical device designed to prevent backflow caused only by back pressure conditions. It is designed to operate under continuous pressure on both sides of the device. A typical pressure type vacuum breaker is illustrated in Fig. 9.24.

3. *Atmospheric type vacuum breaker.* Suitable for minor hazards, the atmospheric type vacuum breaker is a mechanical device designed to prevent backflow caused only by back siphonage conditions. It is designed to operate with pressure

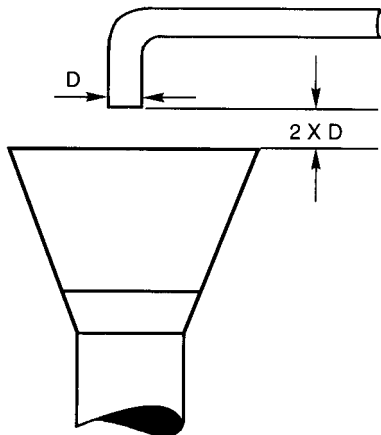

FIGURE 9.23 Detail of typical air gap.

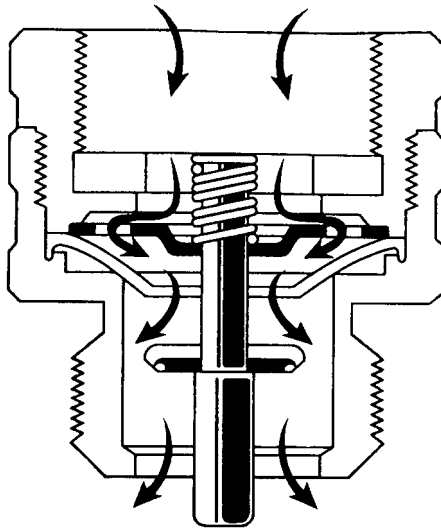

FIGURE 9.24 Pressure type vacuum breaker.

on only one side of the device. A typical atmospheric type vacuum breaker is illustrated in Fig. 9.25.

4. *Double check valve assembly (DCVA)*. Suitable for moderate hazards, a double check valve (Fig. 9.26) is a mechanical device consisting of two independently operating, soft seat, swing check valves. It prevents backflow from back siphonage and back pressure conditions. A variation adds a means of detection to this assembly.

5. *Reduced pressure zone*. Suitable for severe hazards, a reduced pressure zone backflow preventer (Fig. 9.27) is a mechanical device consisting of two independently operating, soft seat, spring-loaded, check valves with the addition of an independent, differential pressure relief valve installed between the check valves,

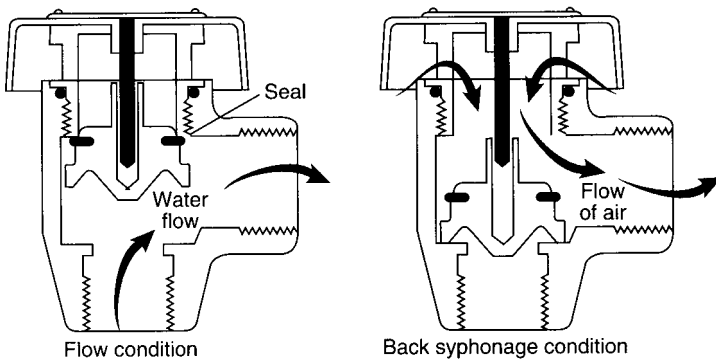
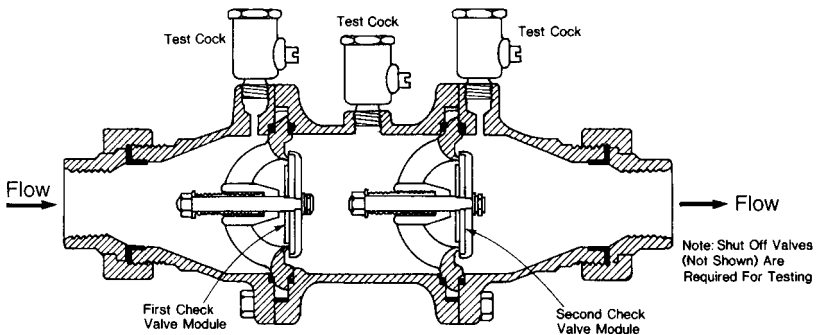

FIGURE 9.25 Atmospheric type vacuum breaker.



#### Double Check Valve Assembly

A backflow prevention device consisting of two independently acting check valves, internally force loaded to a normally closed position between two tightly closing shut-off valves, and with means of testing for tightness.

**FIGURE 9.26** Double check valve backflow preventer.

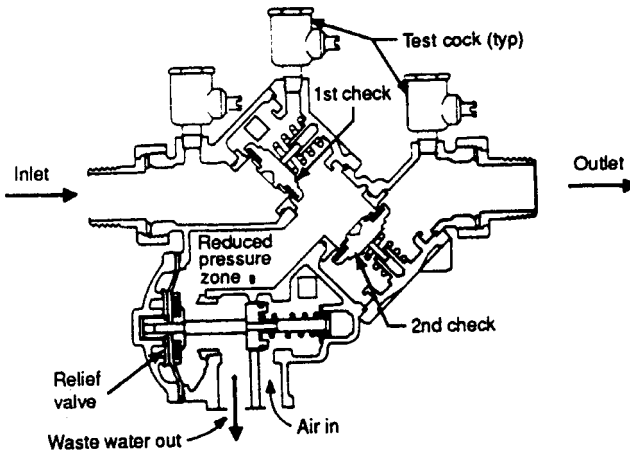

**FIGURE 9.27** Reduced pressure zone backflow preventer.

in the region of the assembly called the reduced pressure zone (RPZ). The relief valve will open under backflow conditions, and discharge all the upstream water under pressure until the condition is corrected. With the potential for large flows, it is accepted practice to direct the discharge outside a facility. Typical discharge from an RPZ can be found in Fig. 9.28. Consult the manufacturer of the selected RPZ for actual values.

The supplier of public potable water is responsible for protecting the public distribution system from contamination by any nearby contaminated water source, such as a pond or stream, that may be used by a fire department to fight a fire at a project location. Depending on local regulations, it may be necessary to provide

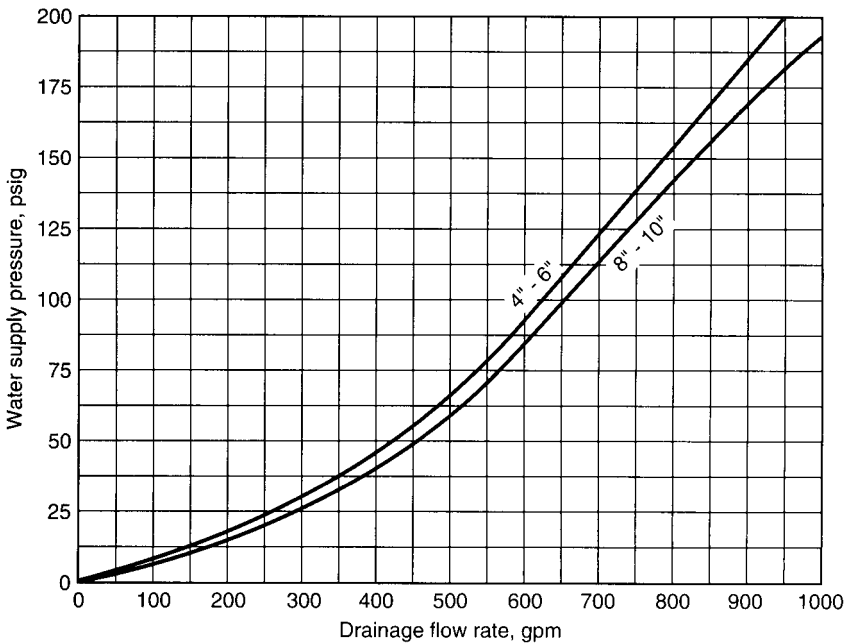

**FIGURE 9.28** Discharge from a typical RPZ backflow preventer.

backflow protection on the site main before it connects to the public source of water.

Another aspect of contamination protection is the disinfection of the entire potable water system, including both the interior and site water supply. Code requires disinfecting interior water piping. A commonly referenced standard for site water mains is AWWA C651, Standard for Disinfecting Water Mains. Refer to Chap. 6 for additional discussion of backflow prevention for site water supply.

## WATER VELOCITY

The velocity of water flowing through the piping system should be kept low enough to prevent objectionable noise, water hammer, and accelerated component wear due to erosion or nuisance splashing of water from fixtures. In order to avoid excessive noise, generally accepted practice for commercial buildings is to limit water velocity to between 6 and 8 fps (2 to 2.3 ms). For industrial projects, 10 fps (3 ms) is acceptable in work areas where the noise is not noticeable. For theaters and similar projects, 4 to 6 fps is desirable. If the water supply is controlled by a quick-closing valve, the velocity should be limited to approximately 4 fps (1.4 ms) to avoid water hammer.

## WATER DISTRIBUTION SYSTEMS

The purpose of a water distribution system is to deliver both hot and cold water, in an acceptable range of pressure and temperature to fixtures and equipment in all parts of a building. All distribution systems can be divided into either upfeed or downfeed systems.

In the typical downfeed system (Fig. 9.29), water is supplied down through vertical pipes to the lowest point in the pressure zone. In a typical upfeed system (Fig. 9.30), the water is supplied upward through vertical pipes to the highest point in the pressure zone. If street pressure is not enough to provide sufficient pressure at the top floor, a booster pump system is required.

The choice of a system is based on several factors, such as the space requirements to run the hot and cold water distribution mains, origin of the source of supply, and economics. The downfeed system generally has smaller pipe sizes and is usually more economical than an upfeed system.

## ESTIMATING WATER DEMAND

The calculation of maximum demand is approximate because it is not possible to predict exactly how many fixtures or various pieces of equipment may be in use at

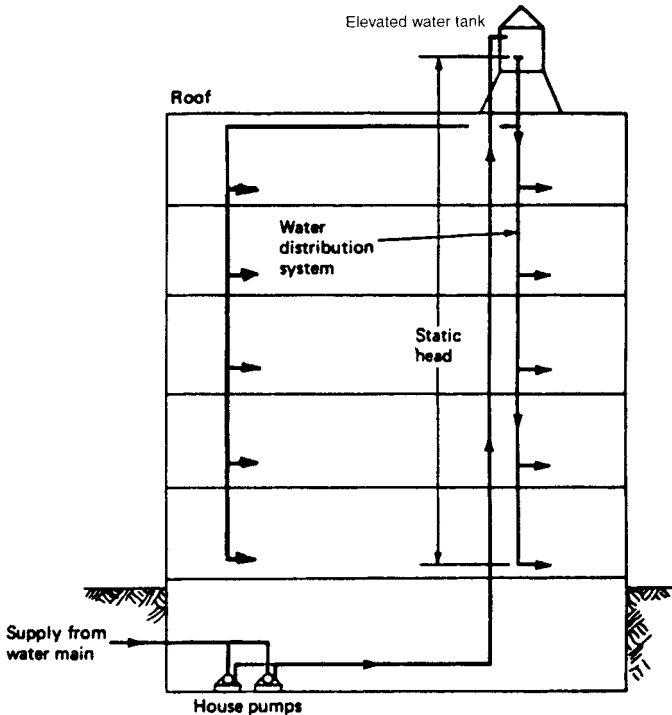
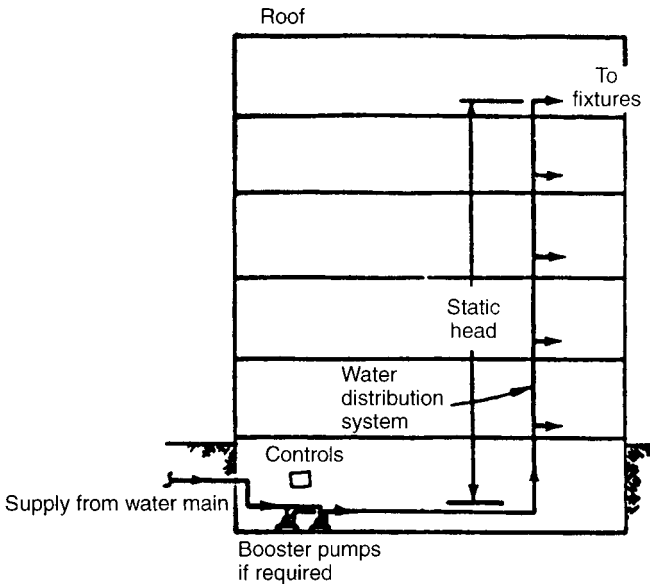

FIGURE 9.29 Simplified downfeed water supply system with simplified elevated water tank.



**FIGURE 9.30** Simplified upfeed water supply system.

the same time. The estimate used for sizing should allow for the probability that the calculated flow will be exceeded occasionally, but not permit wasteful oversizing because the estimate will rarely be exceeded.

The method used to calculate the maximum probable demand is based on water fixture units (WFU) converted into gpm. The Hunter Method is used for this conversion. It has been long recognized that the Hunter Method, which is based on a statistical analysis of how often various fixtures are in use simultaneously, did not consider many types of modern facilities. In some cases, this method resulted in oversized piping and, in others, undersized piping. Studies have been undertaken to investigate the application of the Hunter curve for the purpose of providing a more accurate method of determining peak flow.

These studies have been completed using computers and a new methodology with statistical methods that were not available to Hunter. They have not been adapted by the model or regional codes, but are being considered. New building classifications have been proposed with the intention of revising or replacing the Hunter curve to provide more accuracy. They are:

1. *Residential.* The fixtures are limited to household and personal care. Examples are one- and two-family dwellings.
2. *Commercial.* Access to fixtures is limited to those people regularly occupying this type of building, including multiple dwellings, hotels, small business offices, and small professional buildings.
3. *Public access, need driven.* Access to centrally located fixtures is determined primarily by a biological need, with a social need also present. Examples are large office buildings, industrial facilities, shopping centers, and restaurants without banquet capabilities.

4. *Public access, event driven.* Access to centrally located fixtures is determined primarily by an event. Examples are schools, places of public assembly, stadiums, transportation terminals, and institutions.

The Hunter curve with variations is the method of choice in obtaining peak flow. In some cases, such as facilities with known periods of high use (such as in number 4 in the previous list), the flow shall be increased to allow for this intensive period of fixture usage.

Refer to Table 9.1 for WFU values for typical fixtures. To determine the estimated peak maximum flow rate in gpm for accumulated WFUs at any point in the system, use Table 9.21. This table is a variation of the original Hunter curve. Interpolate to find intermediate values.

Table 9.28 is divided into two sections, one for systems containing flush-valve-operated water closets in addition to other fixtures, and the other for flush-tank water closets in addition to other fixtures. Use the appropriate column for the specific branch or system under design. For the most accuracy, when calculating individual branch flow rates to fixtures using both hot and cold water, use 75 percent of the listed WFU value.

## **DESIGN OF THE WATER SUPPLY DISTRIBUTION SYSTEM**

---

The water supply system must achieve the following basic objectives:

1. To deliver an adequate volume of water to the most hydraulically remote fixture during minimum pressure and maximum flow conditions
2. To provide adequate water pressure to the most hydraulically remote fixture during minimum pressure and maximum flow conditions
3. To prevent excessive water velocity during maximum flow conditions

The process of pipe sizing and component selection is an iterative one, requiring the design professional to assume initial values and recalculate if necessary using new values, if the initial assumptions prove wrong. Use the following simplified method as a guide to sizing. Additional criteria regarding system components are presented later in this chapter.

Pipe sizing is based on the maximum velocity of water in conjunction with the allowable friction loss in the piping system. The basic method of system design is first to establish values that are fixed, such as the minimum operating pressure of the farthest fixture and the difference in static height of that fixture from the pressure source. The pipe size would then be selected so that the remaining system pressure, in the form of friction loss of the water flowing through the pipe, would be used, but not to exceed recommended velocity figures. For a pumped system, the design engineer has the ability to increase the total dynamic head of the pump in order to provide additional pressure to the piping network if desired. The method for simplified design of a street pressure system is as follows:

1. Find the static and residual source water and the elevation at which the pressures are obtained. The residual pressure is the basis of the sizing procedure. This is discussed in Chap. 6, in the section entitled Potable Water Supply.

**TABLE 9.28** Maximum Probable Flow, gpm (L/s)

Water supply fixture units	Tank-type water closets	Flushometer-type water closets	Water supply fixture units	Tank-type water closets	Flushometer-type water closets
1	1 (0.07)		120	25.9 (2.0)	76 (5.7)
2	3 (0.21)		125	26.5 (2.0)	76 (5.7)
3	5 (0.38)		130	27.1 (2.1)	77 (5.8)
4	6 (0.45)		135	27.7 (2.1)	78 (5.8)
5	7 (0.53)	27.2(2.2)	140	28.3 (2.1)	78.5 (5.8)
6	8 (0.60)	29.1(2.2)	145	29.0 (2.2)	79 (5.9)
7	9 (0.68)	30.8(2.4)	150	29.6 (2.2)	80 (6.0)
8	10 (0.70)	32.3(2.5)	160	30.8 (2.3)	81 (6.1)
9	11 (0.83)	33.7(2.5)	170	32.0 (2.4)	83 (6.2)
10	12.2(0.92)	35 (2.6)	180	33.3 (2.5)	84 (6.3)
12	12.4(0.94)	37.3(2.6)	190	34.5 (2.5)	85 (6.4)
14	12.7(0.96)	39.3(2.8)	200	35.7 (2.6)	86 (6.5)
16	12.9(0.98)	41.2(3.1)	220	38.1 (2.8)	88 (6.7)
18	13.2(1)	42.8(3.2)	240	40.5 (3.0)	90 (6.8)
20	13.4(1.01)	44.3(3.3)	260	43.0 (3.2)	92 (7.0)
22	13.7(1.02)	45.8(3.5)	280	45.4 (3.4)	94 (7.2)
24	13.9(1.03)	47.1(3.6)	300	47.7 (3.6)	96 (7.2)
26	14.2(1.07)	48.3(3.7)	400	59.6 (4.5)	102 (7.4)
28	14.4(1.09)	49.4(3.8)	500	71.2 (5.3)	108 (8.2)
30	14.7(1.1)	50.5(3.9)	600	82.6 (6.3)	113 (8.6)
35	15.3(1.1)	53.0(4.0)	700	93.7 (7.1)	117 (8.9)
40	15.9(1.2)	55.2(4.1)	800	105 (8.0)	120 (9.1)
45	16.6(1.3)	57.2(4.2)	900	115 (8.7)	123 (9.3)
50	17.2(1.3)	59.1(4.3)	1,000	126 (9.5)	126 (9.5)
55	17.8(1.4)	60.8(4.5)	1,500	175 (13.3)	175 (13.3)
60	18.4(1.4)	62.3(4.6)	2,000	220 (16.7)	220 (16.7)
65	19.0(1.5)	63.8(4.7)	2,500	259 (19.7)	259 (19.7)
70	19.7(1.5)	65.2(4.9)	3,000	294 (22.3)	294 (22.3)
75	20.3(1.5)	66.4(5.0)	3,500	325 (24.7)	325 (24.7)
80	20.9(1.6)	67.7(5.1)	4,000	352 (26.7)	352 (26.7)
85	21.5(1.6)	68.8(5.2)	4,500	375 (28.5)	375 (28.5)
90	22.2(1.7)	69.9(5.3)	5,000	395 (30)	395 (30)
95	22.8(1.7)	71.0(5.3)	6,000	425 (32.3)	425 (32.3)
100	23.4(1.8)	72.0(5.4)	7,000	445 (34)	445 (34)
105	24.0(1.8)	73.0(5.5)	8,000	456 (34.6)	456 (34.6)
110	24.6(1.9)	73.9(5.6)	9,000	461 (35)	461 (35)
115	25.3(1.9)	74.8(5.7)	10,000	462 (35)	462 (35)

2. Determine by rough calculation if a water pressure booster or reducing systems are necessary. If pressure adjustment is required, select the appropriate system.
3. Locate main runs and route the water distribution system piping within the building.
4. Calculate pressure losses in the distribution system as follows:
  - a. Estimate the maximum flow in the building water service. This is done by adding all WFUs and converting this number to gpm using Table 9.27.
  - b. Calculate the loss of pressure in the building water service from the source into the building. Add (or subtract) the height difference between the source

and height of main distribution piping inside the building, friction loss of the service line, meter, BFP, valves, and all equipment contributing to any loss of pressure. Allow an additional 5 to 10 psi (35 to 70 kPa) for future losses in water supply source pressure as a safety factor, if applicable.

- c. Find the height of the most hydraulically remote fixture from the height of main distribution piping.
  - d. Find the pressure required to operate the most hydraulically remote fixture from Table 9.28.
5. Add the result of steps 4*b*, 4*c*, and 4*d* together and subtract from the figure obtained in step 1.
  6. Calculate the total equivalent run of water piping to the farthest fixture.
  7. Divide the pressure calculated in step 3 into the pipe run calculated in step 4 to find the friction loss allowable for the piping system. This figure shall be compatible with the following tables used to find pipe friction losses.
  8. Using appropriate pipe friction loss charts or tables (such as Cameron's Hydraulic Data) or Fig. 9.31 (copper pipe), 9.32 (new steel pipe), or 9.33 (old steel pipe) and the estimated water demand, size the piping at each design point. It is helpful to make a specific project table using the pipe size that will provide the allowable friction loss, the maximum gpm for that loss, and the water velocity.
  9. At each design point, do not exceed recommended water velocity.

For a pumped system, steps 1, 3, 4*a*, and 4*b* will determine the suction pressure at the inlet to the pump. Steps 4*c* and 4*d* will establish the fixed pressure requirements. The design engineer can then select a pump with enough pressure to allow a reasonable friction loss in the piping system.

## **ADJUSTING WATER PRESSURE**

---

If the pressure in the water source is sufficient to supply the most hydraulically remote fixture in a building, a street pressure system is the most economical selection.

When the pressure is not adequate, it must be increased. Systems used to increase pressure include elevated water tanks, booster pumps, and hydropneumatic tank systems. If the pressure is excessive, it must be reduced to an acceptable level by a pressure-reducing valve.

### **Excessive Water Pressure**

Water pressure in a water distribution system is considered to be excessive if it will damage, or create conditions that will damage, components of the water distribution system or create a nuisance, for example, water splashing out of a fixture during use.

There is no precise value of water pressure below which the pressure will never damage a water distribution system, and above which, will always damage the system. A widely accepted range is 70 to 80 psi (480 to 550 kPa) psi. Often, the maximum permissible water pressure is stipulated by code.

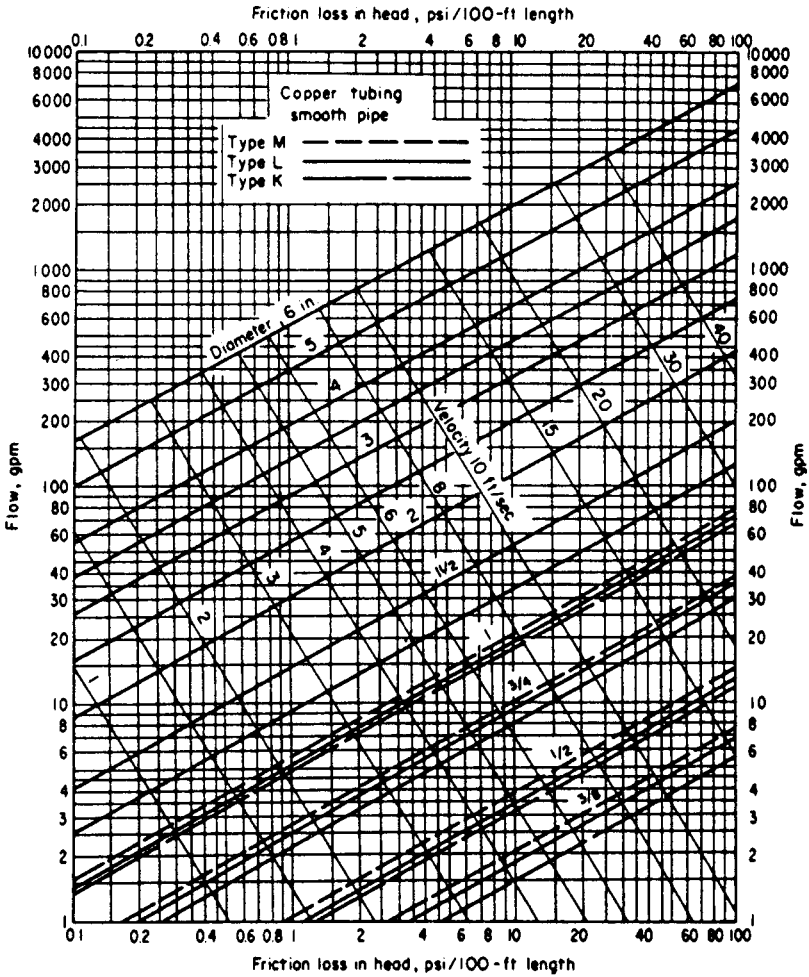

FIGURE 9.31 Flow of water in copper pipe.

A *pressure-regulating valve* (PRV) is a device used to lower and automatically maintain the water pressure within predetermined design parameters for both dynamic and static flow conditions. The PRV uses a closure device that opens and closes an orifice in response to fluctuations in outlet (regulated) pressure. The degree of closure depends upon the ability of a sensing mechanism to detect changes in water pressure at the outlet side of the valve. Pressure-regulating valves fall into two general categories: direct operated and pilot operated.

The *direct-operated* PRV has the closure member controller in direct contact with water pressure in the outlet (regulated) side of the valve. When the outlet pressure varies, the differing pressure causes the closure member to open or close by an amount necessary to achieve the desired outlet pressure. Direct-operated valves are lower in initial cost but provide less accuracy in regulating the outlet



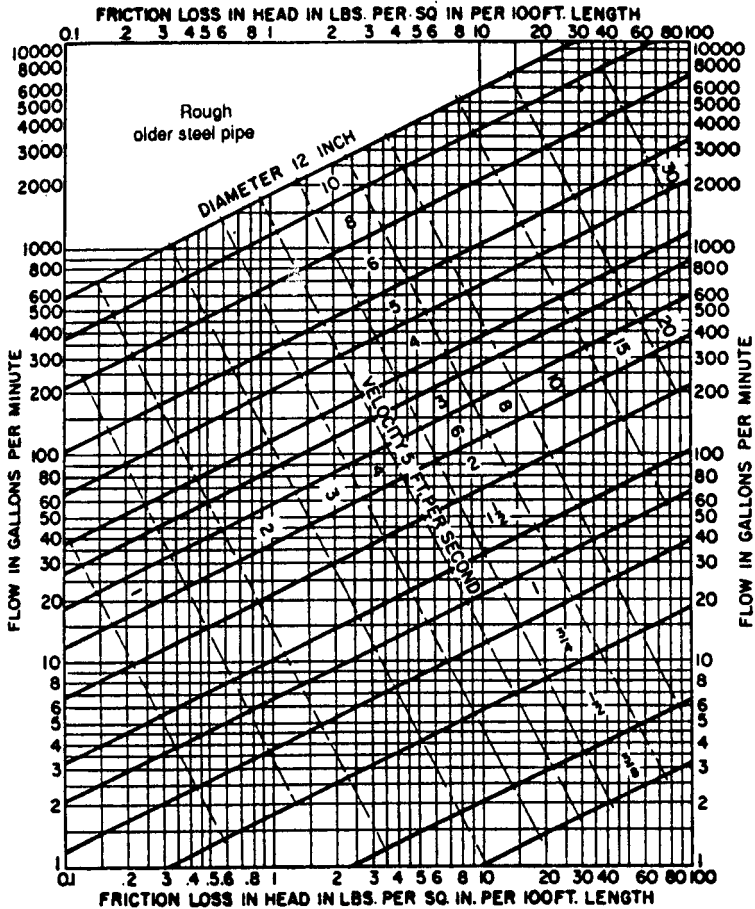

FIGURE 9.33 Flow of water in old steel pipe.

manufacturers for use in valve selection. The following considerations affect the selection of a PRV:

1. *Minimum flow rate.* The minimum rate of flow (other than zero) expected in the piping section under design.
2. *Maximum flow rate.* The maximum rate of flow expected in the piping section under design.
3. *Nature of flow.* Whether the flow rate is reasonably constant or intermittent.
4. *Location of the PRV.* The valve can be located at the beginning or end of a branch.
5. *Maximum inlet pressure.* The highest pressure expected at the inlet of the PRV.
6. *Outlet pressure.* The pressure that the PRV must maintain.

7. *Fall-off*. The difference between the design pressure at which the system has been set and the actual outlet pressure found in the piping—a difference usually limited to approximately 15 psi (105 kPa).
8. *Pressure differential*. The difference between the pressure in the inlet and outlet of the PRV. If this difference is excessive, cavitation may result.
9. *Accuracy of pressure regulation*. The degree of accuracy desired to be maintained within the regulated water distribution system.
10. *Speed of response to changes in pressure*. If this response is too rapid, a noise called *chatter* may result. If the response is too slow, an unacceptably wide variation of pressure may occur at the outlet.

If flow requirements are beyond the recommended capacity of a single PRV, multiple PRVs in parallel are commonly used to allow for low and high flows in a single supply branch. A smaller branch line and a small PRV are set at a lower pressure than the parallel larger branch and larger PRV so that a lower amount of water will flow through the small PRV first. When the pressure loss through the small valve is too great, the larger PRV will open, providing pressure regulation at higher flows.

### Water Pressure-Boosting Systems

Water pressure in buildings may be increased by the following pressure-boosting systems:

1. Elevated water tank
2. Booster pump
3. Hydropneumatic tank

A combination of two such systems, called a hybrid system, may be used where a single type is impractical or uneconomical.

Minimum pressures for various plumbing fixtures as well as a maximum allowable pressure in the system are often stipulated in codes. These values of pressure must be used as a basis for system design unless more stringent values are required for the project under design. Generally accepted minimum values of operating pressure for various fixtures are given in Table 9.29. For special equipment not mentioned, consult the equipment manufacturer.

***Elevated Water Tank.*** In an elevated water tank system, such as the simplified system shown in Fig. 9.29, water is pumped from the water main to an elevated water storage tank (commonly called a gravity tank or a house tank) located above the highest and most hydraulically remote point in the water supply system of the building. A schematic piping arrangement between the components of an elevated water tank system is illustrated in Fig. 9.34. The height of the tank provides additional static head, resulting in a higher pressure in the water distribution system.

The advantages of the elevated water tank system are:

1. It is less complex than either of the other two systems.
2. Fewer components are required to control and operate the system.
3. The efficiency is greater and operating costs are lower than for either of the other systems.

**TABLE 9.29** Minimum Acceptable Operating Pressures for Various Fixtures

Fixture	Pressure, psi*
Basin faucet	8
Basin faucet, self-closing	12
Sink faucet, $\frac{3}{8}$ in (0.95 cm)	10
Sink faucet, $\frac{1}{2}$ in (1.3 cm)	5
Dishwasher	15–25
Bathtub faucet	5
Laundry tub cock, $\frac{1}{4}$ in (0.64 cm)	5
Shower	12
Water closet gravity, low consumption	20
Water closet flush valve	25
Urinal flush valve	25
Garden hose, 50 ft (15 m), and sill cock	30
Water closet, blowout type	30
Urinal, blowout type	25
Water closet, low-silhouette tank type	30
Water closet, pressure tank	35

\*psi  $\times$  7 = kPa.

4. A smaller pump capacity is required than for either of the other two systems.
5. Pressure fluctuations in the system are small.
6. Maintenance requirements are minimal.

The disadvantages of the elevated water tank system compared with the other two systems are:

1. An exposed tank (or the enclosure around it) may be considered unsightly.
2. The building structure may require reinforcement to support the additional weight of the tank and water.
3. The water in the tank and the supply pipes from the tank are subject to freezing if the tank is exposed.
4. The water pressure on the highest floor(s) may be inadequate requiring an additional pumped system for the top several floors.
5. The possibility exists of a catastrophic tank failure flooding the roof with water.

The capacity of the house tank depends on the type of facility it will serve. Refer to Table 9.30 to find recommended minimum domestic storage volumes of gravity tanks for various building types except multiple dwellings. For multiple dwellings, refer to Fig. 9.35.

To use Table 9.30, first determine the total number of fixtures, regardless of type. Multiply the number of fixtures by the gpm per fixture. Then multiply the resulting figure by the tank size multiplier. This figure is for domestic storage only. To this, add constant uses of water, such as HVAC makeup, fire protection water storage, and any process requirements, if necessary. Select a standard tank size equal to or exceeding the storage required. Standard wood roof tank sizes are given in Table 9.31. If the building is occupied predominantly by women, add 15 percent to the number of gallons of water storage requirements.

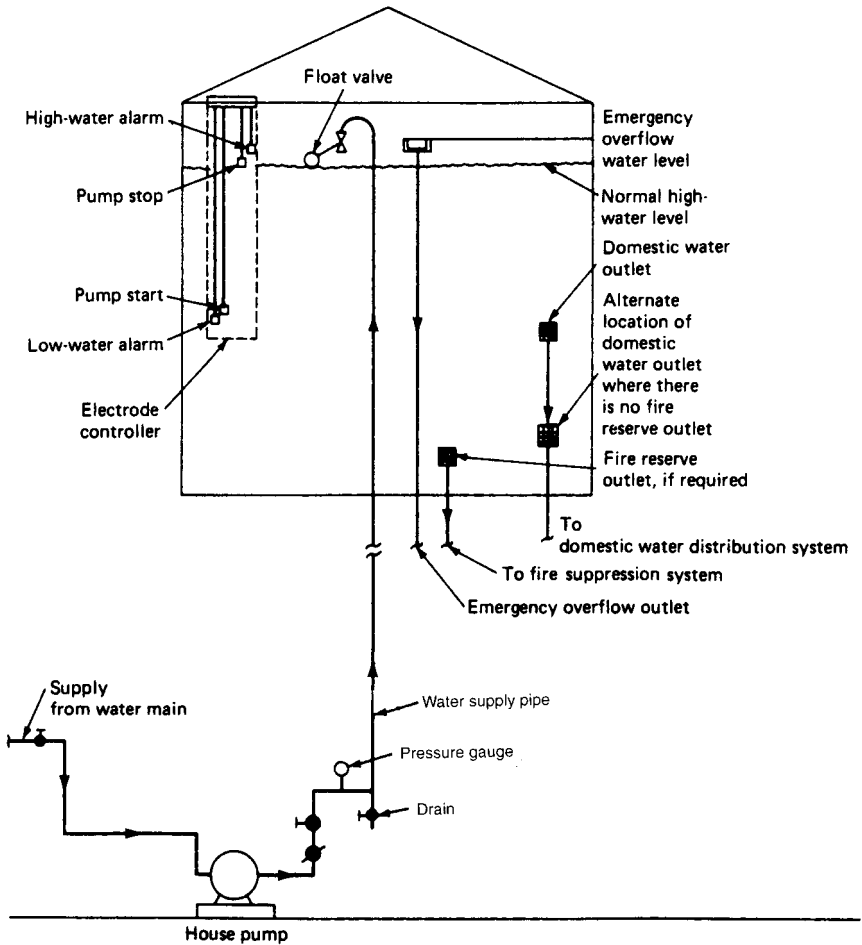

FIGURE 9.34 Piping arrangement of an elevated water tank.

For multiple dwellings, first find the number of apartments. Using Fig. 9.35, find the number of gallons storage per person. If the actual number of people is not available, an approximate number can be found by using two people per bedroom or four people per apartment, whichever is larger, and multiplying by that number. Then multiply the number of people by the number of gallons (liters) required per person to find the domestic storage capacity of the house tank. To this, add constant uses of water, such as HVAC makeup and fire protection water storage, if any. Then select a standard storage tank size equal to or larger than the required amount.

The capacity of the house pump(s) is determined by the quantity of water stored for domestic use. In general, a house pump should be capable of replacing the domestic reserve in about  $\frac{1}{2}$  to 2 h—with 1 h a generally accepted value. A duplex pump arrangement (i.e., two pumps in parallel), with each pump full size, should

**TABLE 9.30** Size of Gravity Tanks

Number of fixtures	gpm per fixture	Tank size multiplier	Minimum domestic capacity, gal	Minimum pump capacity, gpm
Hotels and clubs				
1–50	0.65	30	2000	25
51–100	0.55	30	2000	35
101–200	0.45	30	3000	60
201–400	0.35	25	3000	100
401–800	0.275	25	3000	150
801–1200	0.25	25	3000	225
1201–above	0.2	25	3000	300
Hospitals				
1–50	1	30	2000	25
51–100	0.8	30	2000	55
101–200	0.6	25	3000	85
201–400	0.5	25	3000	125
401–above	0.4	25	3000	210
Schools				
1–10	1.5	30	2000	10
11–25	1	30	2000	15
26–50	0.8	30	2000	30
51–100	0.6	30	2000	45
101–200	0.5	30	3000	65
201–above	0.4	30	3000	110
Industrial buildings				
1–25	1.5	30	2000	25
26–50	1	30	2000	40
51–100	0.75	30	3000	60
101–150	0.7	25	3000	80
151–250	0.65	25	3000	110
251–above	0.6	25	3000	165
Office buildings				
1–25	1.25	30	2000	25
26–50	0.9	30	2000	35
51–100	0.7	30	2000	50
101–150	0.65	25	3000	75
151–250	0.55	25	3000	100
251–500	0.45	25	3000	140
501–750	0.35	25	3000	230
751–1000	0.3	25	3000	270
1001 and above	0.275	25	3000	310

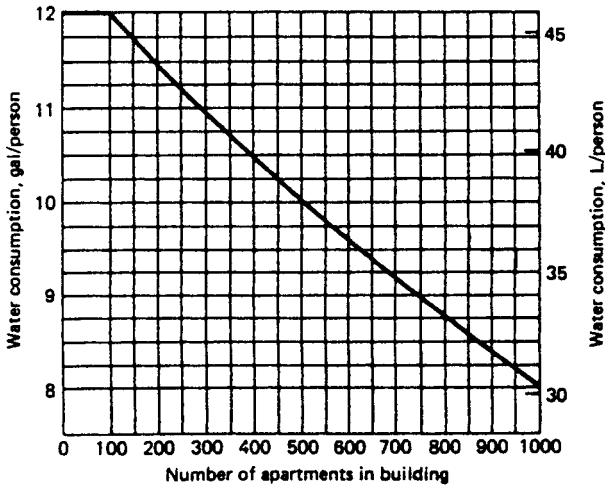

FIGURE 9.35 Estimated water house tank storage capacity, multiple dwellings.

TABLE 9.31 Size of Standard Wood House Tanks

Capacity, gal*	Dimension, ft†		Number of dunnage beams	Dunnage, in‡
	Diameter	Stave		
5,000	10	× 10	5	4 × 6
5,000	9	× 12	5	4 × 6
5,000	11	× 8	6	4 × 6
6,000	11	× 10	6	4 × 6
7,000	11½	× 10	6	4 × 6
7,500	12	× 10	6	4 × 6
7,500	11	× 12	6	4 × 6
8,000	12½	× 10	6	4 × 6
9,000	12	× 12	6	4 × 6
10,000	13	× 12	7	4 × 6
10,000	12	× 14	6	4 × 6
10,000	11	× 16	6	4 × 6
12,000	14	× 12	7	4 × 6
12,000	13	× 14	7	4 × 6
12,000	12	× 16	6	4 × 6
15,000	14	× 14	7	4 × 6
15,000	13½	× 16	8	4 × 6
20,000	16	× 16	8	6 × 6
25,000	17½	× 16	9	6 × 6
30,000	18	× 18	9	6 × 6
40,000	20	× 20	10	6 × 6
50,000	22	× 20	11	6 × 8

\*1 gal = 3.8 L.

†1 ft = 0.3 m.

‡1 in = 25.4 mm.

Source: Isseks Bros. Co.

be provided in case one pump goes out of service. A schematic piping arrangement at the pump is shown in Fig. 9.34.

A common problem with the gravity tank system is the lack of adequate water pressure on the upper floors of the building unless the tank is elevated to an impractical height. Under these conditions, a hybrid system comprising the elevated tank plus a small booster pump system only for the top several floors can be used.

**Booster Pump System.** In a booster pump system, illustrated schematically in Fig. 9.36, the booster pump(s) are supplied from a source with pressure that is both insufficient and variable. A control system senses variations in the distribution system and adjusts either the speed of the pump or a PRV to maintain a constant increased pressure of acceptable value. Two types of booster pump drives are available for adjusting the pressure and flow in the water distribution system, constant speed and constant pressure.

**Constant-speed drive.** This type of drive should be considered where (1) water demand requirements are relatively constant, (2) a low-to-medium boost pressure is required, and (3) a low initial cost is important. It should also be considered where the frictional losses in the piping network are relatively minor.

**Variable-speed drive.** This type of drive is recommended where (1) there are large fluctuations in the water main supply pressure to the pumps, (2) there is a requirement for a high pressure boost, or (3) a great variation is expected in the system water demand. Variable speed drives are also recommended where the friction losses in the water distribution system are relatively high. A variable-speed drive system is higher in initial cost than a constant-speed drive.

**Number of Pumps.** A booster pump system that runs continuously should include pumps of various sizes, so that during periods of little use the smaller pump is used, resulting in a more economical operation. A hybrid system using a small hydropneumatic tank should be considered during off-peak hours to provide additional operating economy by allowing the pump system to be shut down during extended periods of little or no water demand.

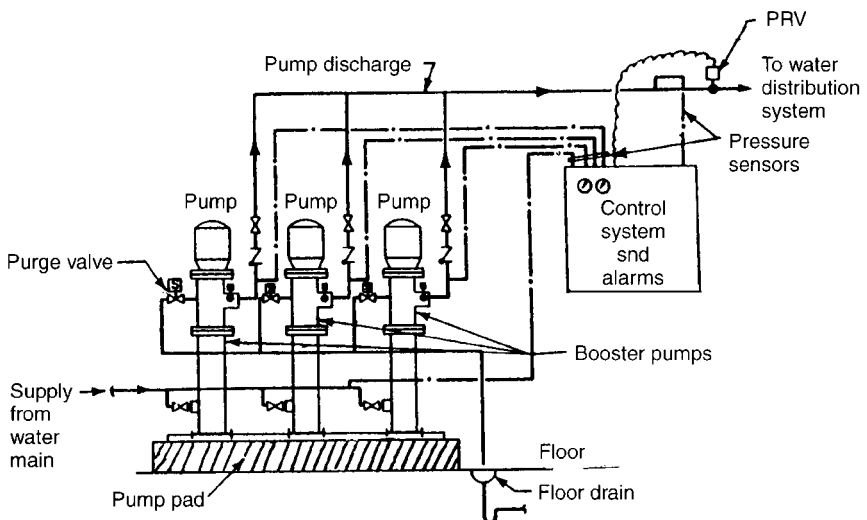

FIGURE 9.36 Schematic detail of booster pump system components.

A two-pump system is usually selected for both redundancy and economy. Each of the two pumps should be capable of supplying 60 percent of the total estimated peak water demand. If maintenance of a total supply of water is a prime consideration, then select three pumps, each of which could supply 50 percent of the total requirements. Then, full system capacity will be maintained even if one of the pumps is out of service.

Water usage studies have shown that in most buildings, the actual water demand is approximately 25 percent of estimated peak demand during three-quarters of a normal working day. If operating cost is a determining factor, the use of three pumps is desirable, sized to provide 50, 50, and 25 percent of the peak estimated demand flow. In this configuration, the smaller pump operates most of the time when the load is low. It also operates in conjunction with the larger pumps during periods of peak demand. A typical three-pump system is shown in Fig. 9.36.

*Variable-Speed Control.* The following control devices are commonly used to vary the speed of either the pump or the motor to maintain satisfactory pressure in the water distribution system:

1. *Electronic controller.* An electronic controller is a solid-state device that controls the current supplied to the motor, thereby varying its speed. This allows the motor to be connected directly to the pump.

2. *Fluid and magnetic couplings.* These variable-speed couplings are used to connect the motor to the pump. These devices use either a fluid (usually water or oil) or electrically induced magnetism to adjust the speed of the pump while the motor rotates at a constant speed.

**Hydropneumatic Tank System.** In a hydropneumatic tank system, such as that shown in the schematic diagram in Fig. 9.37, water is pumped from the water supply into a pressure tank for storage. The air in the tank is compressed by the water entering the tank. As the pressure in the tank is increased, the pressure in the water distribution system is also increased since it is also connected to the tank. The pressure tank may be located anywhere in the building. The water stored in the tank and the pressure in the tank are sufficient to allow the pumps to shut down for a period of time and yet satisfy the demand for water. This conserves energy since the pump need not be in continuous operation. A separate air compressor is provided to make up for any air absorbed by the water. Control of the system is achieved by means of a combination pressure and level control, which adds water or air to the pressure tank at the proper time.

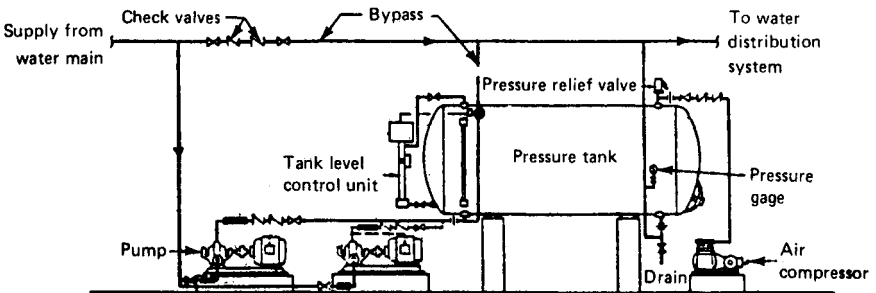

FIGURE 9.37 Schematic detail of hydropneumatic tank components.

Since the total amount of stored water is relatively small, a pressure tank may run out of water during periods of peak demand unless a very large tank is selected. Therefore, the fill pumps must be sized to supply the peak demands of the building at the lowest calculated system pressure. The piping arrangement of such a system must include a tank bypass arrangement to allow the fill pumps to supply the building directly if a sustained peak demand occurs and there is not enough water in the pressure tank to supply the peak demand for an extended period of time.

The size of the air compressor is determined by the size of the storage tank. Select an air compressor that can supply 2 cfm for a tank having a total capacity in excess of 4000 gal (16 000 L) or less.

Because of very high initial cost and the large amount of floor space required, a hydropneumatic system is no longer considered for an entire building supply. Booster pumps have replaced the hydropneumatic tank, although some of these systems still are operating in older buildings. Small hydropneumatic systems are often used as part of a hybrid system to allow booster pumps to be shut down occasionally.

**Hybrid System.** A hybrid system is a combination of two systems. The most common is a small hydropneumatic system used in conjunction with a booster pump for economy in facilities where little or no water is used for extended periods of time. Examples are office buildings or factories that are closed at night. Another hybrid system, consisting of a small booster pump assembly and a house tank, is used to provide a higher pressure to the upper floors where the height of the house tank is limited, such as for multiple dwellings.

## **PIPE SIZE SELECTION**

---

Pipe sizing is accomplished using maximum allowable pressure loss, flow rate, and velocity at the design point. Two methods of determining these values are available. The first uses prepared tables for each pipe size, with the velocity and pressure loss for various flow rates. The second uses nomographs, where all the information is displayed on a single graph. The tables are more accurate but the nomographs are more convenient. The nomographs in Figs. 9.31, 9.32, and 9.33 are provided for smooth, fairly rough, and rough pipes. Special charts have been made for specific plastic types of pipe, but space limitations prevent reproduction in this handbook.

# SERVICE HOT WATER SYSTEMS

## **SYSTEM DESCRIPTION**

---

The service hot water system heats raw water from ambient temperature to a desired higher temperature and delivers the heated water to terminal points with a delay of less than 20 s. A booster hot water system heats primary service hot water to a higher temperature for a specific purpose.

## **CODES AND STANDARDS**

---

In addition to the standard requirements of the applicable plumbing code, many other additional codes are used in the design and manufacture of specific equipment.

1. NFPA code for oil-burning equipment and gas-fired heaters
2. ASME code for pressure vessels, relief valves, etc
3. UL codes for electric and oil-burning heaters
4. ANSI Z-21 heaters and relief valves
5. ASHRAE code for energy conservation

## **WATER HEATING METHODS AND EQUIPMENT**

---

Water heaters are categorized as fully instantaneous, semi-instantaneous, or storage type. They can be either directly or indirectly fired. Direct-fired heaters use a heat source, such as electricity, fuel gas, oil, and solar panels, to directly transfer heat in the heating vessel. Indirect heating uses the fuel to produce a heating medium, such as steam or hot water, that gives up its heat in a heat exchanger.

Fully instantaneous heaters consist of a unit that heats water as quickly as the demand flow rate requires. They have no storage and a high recovery rate. Advantages include little floor space required, low initial cost, and factory preassembly into a package ready to install. Disadvantages are difficult control of outlet water temperature and high instantaneous Btu requirements for the heating medium. For instantaneous heaters, an accurate approximation for steam can be calculated by multiplying the gpm requirements by 50 lb/h. This type of heater is almost always indirectly fired using either steam or hot water supplied from a central heating plant, steam utility system, or a boiler.

Semi-instantaneous heaters are similar to the fully instantaneous types except that they have a very small water storage capacity which permits better control of outlet water temperature. This type of heater can be either directly or indirectly fired, and is preferred over the fully instantaneous type. Refer to Fig. 9.38 for a detail of a typical semi-instantaneous water heater.

Storage heaters have a large storage capacity and low recovery rate. This system consists of either a combination storage tank and a direct or indirect immersion heater inside the tank or separate water heater and storage tank. This system should

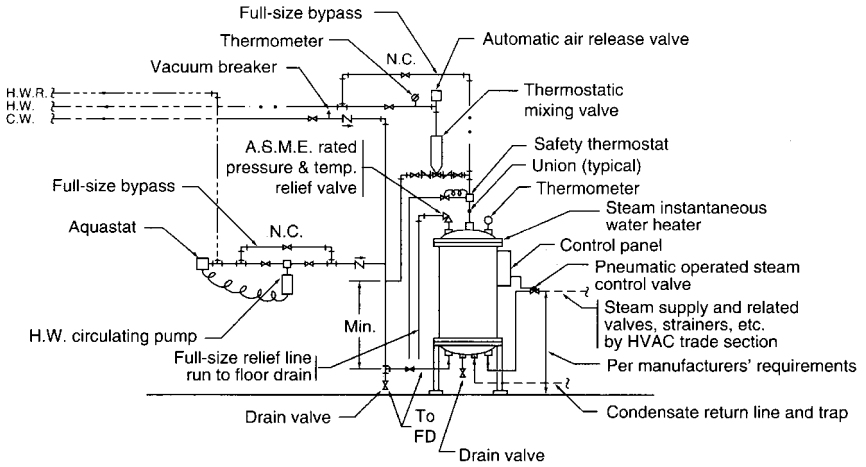

FIGURE 9.38 Detail of semi-instantaneous water heater.

be considered when high peak surge loads are encountered for short periods of time and when a limited source of heat energy exists. Disadvantages include a large amount of floor space required and high initial cost. Advantages include a low instantaneous heat energy demand rate. Refer to Fig. 9.39 for a detail of a typical storage heater.

Point-of-use heaters are usually direct fired and are used for isolated and remote locations where it is not economical to run piping from the central service hot water system. Popular units are electric in-line instantaneous heaters installed below an

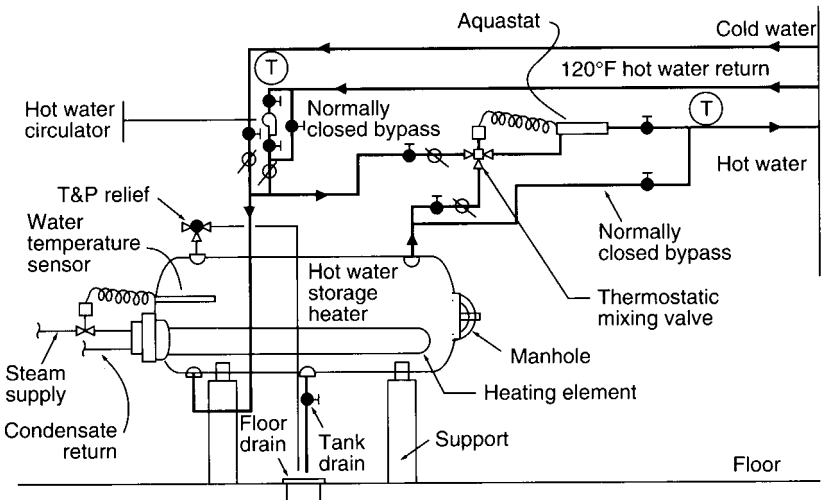

FIGURE 9.39 Detail of storage type water heater.

individual fixture or 5-gal (20-L) units installed on a shelf or in a hung ceiling adjacent to a service sink or similar installation.

The fuels that are most frequently used to heat water are electricity, fuel oil, fuel gas, and solar energy. The choice of a primary fuel for central water-heating systems depends on the following considerations:

1. Availability of fuel
2. Cost
3. Availability of heating equipment using the desired fuel
4. Space requirements and cost for vents or flues
5. Fuel storage space and applicable regulations
6. Client preferences

### **ACCEPTABLE HOT WATER TEMPERATURES**

---

Table 9.32 lists the generally acceptable minimum temperatures for common purposes, various plumbing fixtures, and other pieces of equipment. Other codes and standards, particularly for hospitals and health care facilities, may further restrict the allowable temperature of the hot water supplied for various uses. These figures must be obtained from such codes and standards required by authorities.

**TABLE 9.32** Minimum Hot Water Temperature for Plumbing Fixtures and Equipment

Use	Minimum temperature, °F
Lavatory:	
Hand washing	105
Shaving	115
Showers and tubs	110
Commercial and institutional laundry	180
Residential dishwashing and laundry	140
Commercial spray-type dishwashing as required by National Sanitation Foundation:	
Single or multiple tank hood or rack type:	
Wash	150
Final rinse	180 to 195
Single-tank conveyor type:	
Wash	160
Final rinse	180 to 195
Single-tank rack or door type:	
Single-temperature wash and rinse	165
Chemical sanitizing glasswasher:	
Wash	140
Rinse	75

## **WATER HEATER SIZING**

---

Hot water usage and flow rates are characterized by intermittent periods of peak, sustained, and low to zero flow conditions. The pattern and usage requirements vary depending on building type and use, equipment, population, and time of day.

Each different type of water heater is sized using different criteria. Both types of instantaneous heaters are sized only on the maximum peak flow rate. Storage heaters are sized using the recovery rate in conjunction with the storage capacity to satisfy demand over a period of time ranging from 1 to 4 h. Determination of the recovery and storage criteria can be based on either population or the number of fixtures in the facility. Population is the more accurate criterion when available.

When designing a project for a client with a preference for specific heater types and sizing criteria, such as various city and state agencies, the federal government, and Department of Defense, the design engineer must follow the methods established by the client. When no criteria exist, sizing should be based on accepted practices, such as those published by the ASPE and ASHRAE. It must be emphasized that sizing water heaters is as much an art as a science, with many possible methods capable of specifying adequately sized equipment for facility needs.

### **Instantaneous and Semi-instantaneous Water Heater Sizing**

Instantaneous and semi-instantaneous water heaters are sized by the fixture unit method, calculating the maximum hot water flow rate in gpm. The gpm for hot water alone is less than the value found for fixtures using both hot and cold water. The maximum fixture demand is found by using a specialized hot water WFU table and a modified Hunter curve converting hot water WFUs into gpm.

Table 9.33 assigns hot water demand in WFUs for various fixtures. Figures 9.40 and 9.41 convert the WFUs into gpm using a modified Hunter curve for hot water depending on the total WFUs calculated. To the maximum fixture demand, add other equipment, such as food service, laundries, and the like, used in the facility.

### **Storage-Type Water Heater Sizing**

Storage-type heaters are sized using the total volume of hot water required for the estimated duration of maximum demand. This total volume can be provided by any combination of hot water storage capacity and water heater recovery rate. Storage and recovery values depend on the type of project. The major advantage of using a storage heater is that the instantaneous demand for steam (or other heating media) is considerably less than that for instantaneous heaters.

One disadvantage of a storage tank is that more cold water will enter the tank than can be heated to the desired temperature. An allowance called the cold water correction factor must be made to provide for the fact that the temperature of the water in the tank will be lowered when this happens. The generally accepted figure is that no more than approximately 30 percent cold water can enter the tank before the temperature of the water is lowered below acceptable limits. Conversely, only 70 percent of water in a storage tank is considered useful.

No single sizing method is considered suitable for all building types. Three criteria are commonly used: (1) number of fixtures, (2) population, and (3) flow rate.

**TABLE 9.33** Hot Water Demand in Fixture Units at 140°F (60°C)

Type of fixture	Fixture units	Type of fixture	Fixture units
Hospital		Assoc. Bldg. YMCA	
Private lavatories	0.75	Private lavatory	0.75
Public lavatories	1.0	Public lavatory	1.0
Semiprivate lavatories	1.2	Private shower‡	1.5
Private shower‡	1.5	Tub and shower‡	1.7
Ward shower‡	2.5	Service sink	2.5
Semiprivate shower‡	1.5	Laundry tray	2.0
Private bath	1.5		
Ward bath	2.0	Restaurant†	
Sink—flushing rim	2.0	Private lavatory	0.7
Sink—scrub-up	1.5	Public lavatory	2.0
Sink—laboratory	1.5	Private shower‡	1.5
Sink—general purpose	1.0	Public shower‡	1.7
Bath—leg	6.0	Sink—kitchen	3.0
Bath—arm	4.0	Sink—pantry	2.5
Bath—sitz	3.0	Service sink	2.0
Bath—foot	3.0	Sink—pot (single)	2.5
Bath—emergency	2.0	Sink—pot (double)	3.5
Hydrotherapeutic showers:		Sink—pot (triple)	5.5
#1 shower head	8.0	Sink—vegetable	2.0
#2 spray	1.2	Sink—bar	2.5
Continuous flow bath		Washer—silver	2.0*
Continuous flow fill	2.0	Washer—glass	2.0*
Continuous flow operate	1.5	Washer—can	3.0
Hubbard	4.0	Coffee urn	1.2
Autopsy table	2.0	Baine marie	1.0
Autopsy sink and table	2.5	Pot and pan washer	2.0*
		Dish prerinse	2.5
Club		Prescraper	2.0
Private lavatory	0.75	Prescraper conveyor	2.5
Public lavatory	1.0	36" half Bradley	1.0
Private shower‡	1.5	36" full Bradley	1.5
Public shower‡	1.7		
Tub and shower‡	1.5	Typical dishwashers (Use booster to heat from 140° to 180°F.)	
Service sink	2.5	Single tank stationary rack	
36" half Bradley	1.0	16 × 16 rack	2.2
36" full Bradley	1.5	18 × 18 rack	3.7
54" half Bradley	1.5	20 × 20 rack	4.0
54" full Bradley	2.0	Multiple tank conveyor type	
		Dishes—inclined	2.0
Gymnasium		Dishes—flat	2.5
Private lavatory	0.75	Single tank conveyor type	2.3
Public lavatory	1.0		
Private shower‡	1.5	Hotel-motel	
Public shower‡	3.0	Private lavatory	0.75
Sink—slop	1.5	Public lavatory	1.0
Basin—foot	1.2	Private shower‡	1.5
36" half Bradley	1.0	Tub and shower‡	1.5
36" full Bradley	1.5	Basin—barber	2.0
54" half Bradley	1.5	Service sink	2.5
54" full Bradley	2.0	Basin—beauty parlor	2.5

**TABLE 9.33** Hot Water Demand in Fixture Units at 140°F (60°C) (*Continued*)

Type of fixture	Fixture units	Type of fixture	Fixture units
Office bldg.		Multiple dwelling	
Private lavatory	0.75	Private lavatory	0.75
Public lavatory	1.0	Public lavatory	1.0
Private shower‡	1.5	Private shower‡	1.5
Service sink	2.5	Public shower‡	1.5
Janitor drop	2.5	Tub and shower‡	1.5
36" half Bradley	1.0	Sink—kitchen	0.75
36" full Bradley	1.5	Sink—slop	1.5
		Sink—pantry	1.5
		Domestic clothes washer	1.2
		Domestic dish washer	1.5
		Laundry tray	1.5
Factory		Private—public school	
Private lavatory	0.75	Private lavatory	0.75
Public lavatory	1.0	Public lavatory	1.0
Private shower‡	1.5	Private shower‡	1.5
Public shower‡	3.0	Tub and shower‡	1.7
Service sink	2.5	Service sink	2.5
36" half Bradley	1.0	Janitor drop	1.5
36" half Bradley	1.5	Domestic clothes washer	2.0
54" half Bradley	1.5	Domestic dish washer	2.0
54" half Bradley	2.0		
Correctional or mental institution		Institution—home	
Private lavatory	0.7	Private lavatory	0.7
Public lavatory	1.0	Public lavatory	1.0
Private shower‡	1.5	Private shower‡	1.5
Public shower‡	3.0	Tub and shower‡	1.5
Tub and shower‡	1.5	Service sink	2.0
Sink—slop	2.0	Laundry tray	2.0
Janitor drop	2.0		
36" half Bradley	1.0		
36" full Bradley	1.5		
54" half Bradley	1.5		
54" full Bradley	2.0		

\*These items require 180°F hot water. The consumption figures are based on supplying 140°F water with a booster heater used to obtain 180°F water.

‡Add 20% to all figures when not used in combination with other building services from same heater.

‡The fixture units listed for shower heads are based on a flow rate of 3 gpm. These units should be corrected for other flow rates. Multiply the fixture units by Correction Factor "C" from the formula:  $C = G \times .33$ . Where C = Correction Factor, G = gpm of shower head being used. Example: Shower head 4 gpm =  $C = 4 \times .33$  or 1.32. From Fixture Capacity Table, Hotel-Motel (showers) which shows 1.5 fixture units, multiply  $1.5 \times 1.32 = 2.0$  fixture units per shower head using 4 gpm.

Source: Patterson-Kelly.

**Sizing Based on Number of Fixtures.** Fixtures are often used as criteria for design of buildings such as health care facilities. The occupants of these facilities use the fixtures over an extended period of time, and the number of fixtures are generally proportional to the number of people. This sizing method calculates the total anticipated volume in gallons (liters) of hot water for the peak duration of use and a storage tank capacity. The following simplified procedure will find the volume of hot water required.

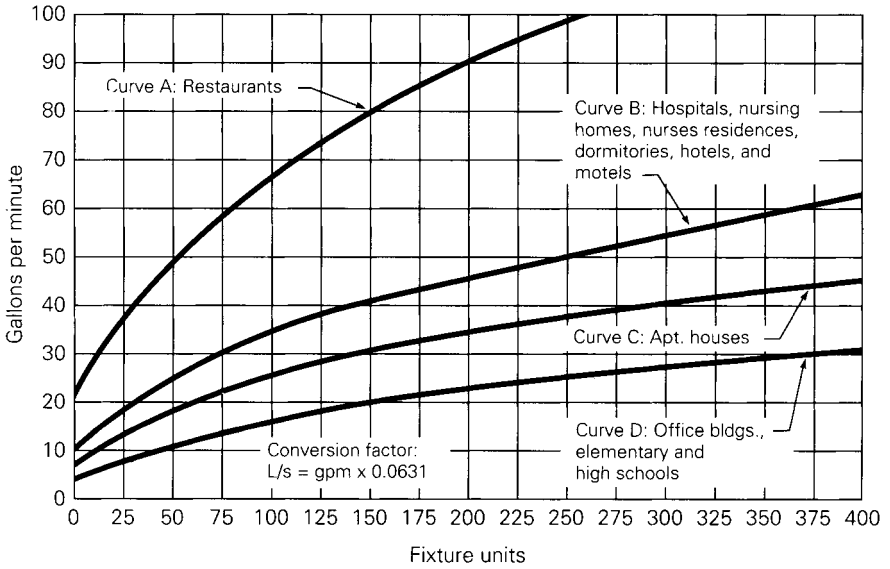

FIGURE 9.40 Modified Hunter curve for hot water, enlarged section.

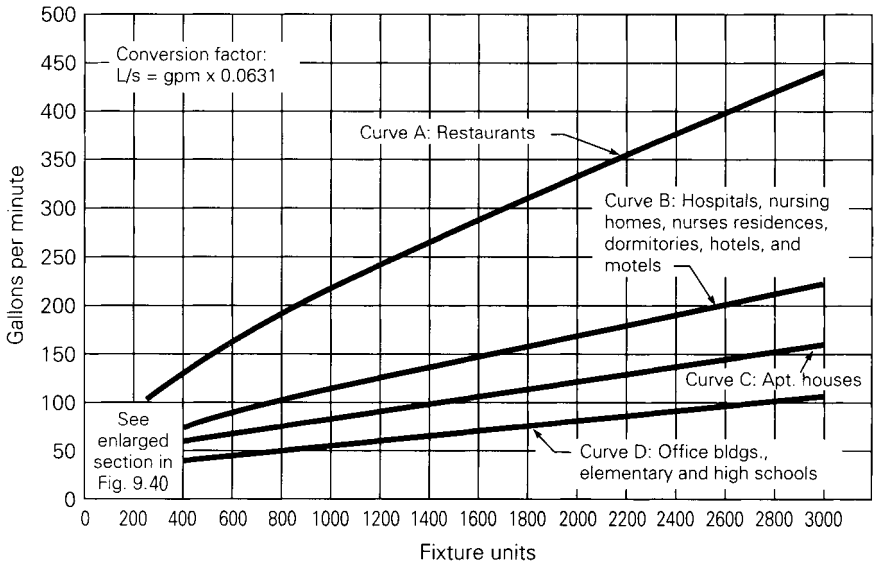

FIGURE 9.41 Modified Hunter curve for hot water.

1. Using Table 9.34, select the facility in the table that is closest to the actual facility. Count the total number of each type of fixture found at the facility and assign the gallons per hour value for each fixture found under the selected building type heading.

2. Multiply the value found for each separate fixture by the total number of individual fixtures.

3. Add the resultant figure from all individual fixture types together to get a total connected load in gallons (liters) of water per hour.

4. Find the actual hourly demand for the facility by multiplying the total connected load calculated in step 3 by the demand factor at the bottom of Table 9.34. The resulting figure is the actual volume of hot water that will be used by the facility during a 1-h period of time.

5. In conjunction with the total hourly demand, a recommended amount of hot water shall be stored. The volume of storage is a function of the actual hourly demand. The storage requirement is found by multiplying the total hourly demand (found in step 4) by the storage capacity factor found at the bottom of Table 9.34. The result is the usable volume of hot water required to be stored. To find the actual required capacity, add an additional 30 percent of the calculated volume of the usable capacity.

6. The recovery requirement and the storage requirement represent one hour's peak use of hot water. Select any combination of heating capacity (recovery) and storage capacity capable of meeting this peak hour. Consultation with the supplier of the heating medium would be helpful in determining the Btus available from the central plant. If the duration is longer than 1 h, proceed to the next step.

7. Refer to Table 9.35 to determine if the facility should have more than a 1-h peak usage duration. If so, multiply the actual hourly demand by the number of hours duration to find the total volume, in gallons (liters) of hot water required for the entire peak period. Select a recovery rate and storage tank capacity combination for that amount. As an example, if the actual hourly demand is found to be 1000 gal/h for a duration of 3 h, the total volume of hot water required will be 3000 gal. If the usable storage volume is 1000 gal, the recovery rate required for the 3-h period will be  $2000 \div 3$ , or 670 gal/h. The total of 1000 gal storage + 2010 gal makeup ( $670 \times 3$ ) will equal slightly more than the 3000 gal required.

8. To determine the volume of water for any temperature other than 140°F, use the following formula:

$$CF = \frac{100 - IWT}{HDT - IWT} \div 0.6 \times \text{actual hourly demand} \quad (9.2)$$

where CF = correction factor

IWT = inlet water temperature

HDT = heater water discharge temperature

Multiply the actual by the CF to find the adjusted hourly demand.

**Sizing Based on Population.** Population should be the criterion for design when the number of fixtures does not necessarily correlate to the number of people using the facility, for example, in residence-type projects, hotels, motels, schools, and nursing homes.

This method of sizing calculates the total anticipated volume in gallons (liters) of hot water, the recovery, and storage tank capacity for 1 h. Figures 9.42a to 9.42h

**TABLE 9.34** Hot Water Demand in Gallons (Liters) per Hour at 140°F (60°C)

	Apartment house	Club	Gymnasium	Hospital	Hotel	Industrial plant	Office building	Private residence	School	YMCA
1. Basins, private lavatory	2 (7.6)	2 (7.6)	2 (7.6)	2 (7.6)	2 (7.6)	2 (7.6)	2 (7.6)	2 (7.6)	2 (7.6)	2 (7.6)
2. Basins, public lavatory	4 (15)	6 (23)	8 (30)	6 (23)	8 (30)	12 (45.5)	6 (23)	—	15 (57)	8 (30)
3. Bathtubs	20 (76)	20 (76)	30 (114)	20 (76)	20 (76)	—	—	20 (76)	—	30 (114)
4. Dishwashers*	15 (57)	50–150 (190–570)	—	50–150 (190–570)	50–200 (190–760)	20–100 (76–380)	—	15 (57)	20–100 (76–380)	20–100 (76–380)
5. Foot basins	3 (11)	3 (11)	12 (46)	3 (11)	3 (11)	12 (46)	—	3 (11)	3 (11)	12 (46)
6. Kitchen sink	10 (38)	20 (76)	—	20 (76)	30 (114)	20 (76)	20 (76)	10 (38)	20 (76)	20 (76)
7. Laundry, stationary tubs	20 (76)	28 (106)	—	28 (106)	28 (106)	—	—	20 (76)	—	28 (106)
8. Pantry sink	5 (19)	10 (38)	—	10 (38)	10 (38)	—	10 (38)	5 (19)	10 (38)	10 (38)
9. Showers	30 (114)	150 (568)	225 (850)	75 (284)	75 (284)	225 (850)	30 (114)	30 (114)	225 (850)	225 (850)
10. Service sink	20 (76)	20 (76)	—	20 (76)	30 (114)	20 (76)	20 (76)	15 (57)	20 (76)	20 (76)
11. Hydrotherapeutic showers				400 (1520)						
12. Hubbard baths				600 (2270)						
13. Leg baths				100 (380)						
14. Arm baths				35 (130)						
15. Sitz baths				30 (114)						
16. Continuous-flow baths				165 (625)						
17. Circular wash sinks				20 (76)	20 (76)	30 (114)	20 (76)		30 (114)	
18. Semicircular wash sinks				10 (38)	10 (38)	15 (57)	10 (38)		15 (57)	
19. DEMAND FACTOR	0.30	0.30	0.40	0.25	0.25	0.40	0.30	0.30	0.40	0.40
20. STORAGE CAPACITY FACTOR†	1.25	0.90	1.00	0.60	0.80	1.00	2.00	0.70	1.00	1.00

\*Dishwasher requirements should be taken from this table or from manufacturers' data for the model to be used, if this is known.

†Ratio of storage tank capacity to probable maximum demand/h. Storage capacity may be reduced where an unlimited supply of steam is available from a central street steam system or large boiler plant.

Source: ASPE.

**TABLE 9.35** Duration of Peak Use

Building type	Peak duration, hours
Motel	2
Hotel	3
Apartment house	3
Nursing home	3
Office	2
Food service	1 to 4 (varies with type)

provide infinite combinations of storage and recovery for use with this method. The chart ranges have been selected based on the studies that produced this method of design. Any requirements imposed by heating medium and space restrictions can be satisfied by selecting an acceptable combination.

1. Using Fig. 9.42, find the type of facility under design. Determine the population of the facility.
2. Entering the chart, select the combination of storage and recovery desired.
3. Using the chart curve, read the usable storage capacity and recovery figure per person in gal/h.
4. Calculate the total usable storage and recovery capacity that satisfies project requirements by multiplying the separate recovery and storage figures by the population.
5. Add an additional 30 percent to the calculated usable volume of storage to determine the total storage capacity to allow for the cold water correction factor.
6. Add a water temperature correction if necessary.
7. A system heat loss of 15 Btu/ft run of pipe shall be added to the gal/h recovery figure calculated to make up for the heat lost from the entire system. This is only necessary for the population method because no consideration for this heat loss was made in the hot water usage criteria.

**Sizing Based on Flow Rate.** Flow rate should be the criterion for design of specialized buildings, such as convention centers, prisons, sporting arenas, and gymnasiums, where predictable, concentrated peak usage periods occur. The following simplified procedure will find the volume of hot water required:

1. Determine the duration, in hours or minutes of peak use.
2. Find the typical flow rate of all fixtures contributing to flow during the peak duration from Table 9.1.
3. Establish the amount of time the fixtures are actually used during the peak duration.
4. Select a combination recovery rate and storage tank capacity that will supply the calculated amount of hot water for the peak duration.

**Additional Sizing Criteria.** Table 9.36 has been prepared from actual metered data from a limited number of the various facilities indicated. Because of the limited study it has not been generally accepted as a sizing guide but does allow a check

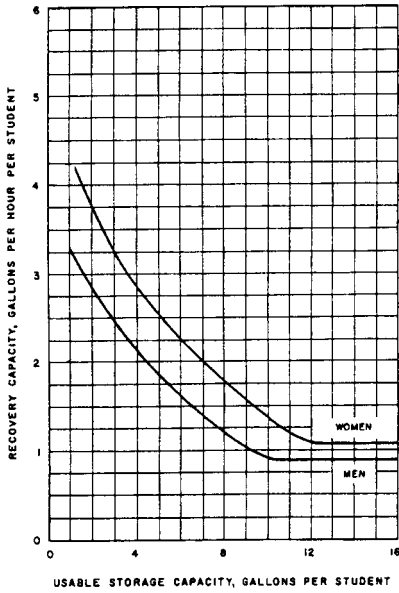

(a) Dormitories

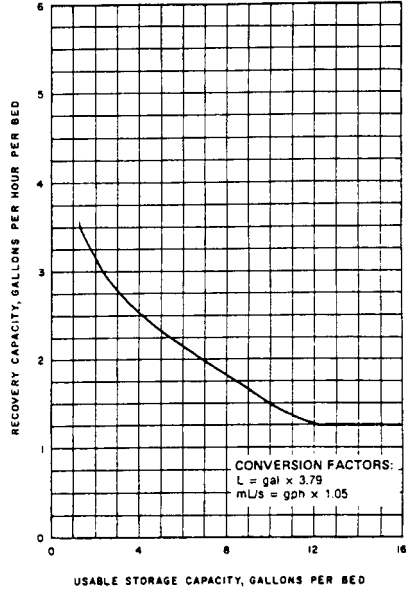

(b) Nursing Homes

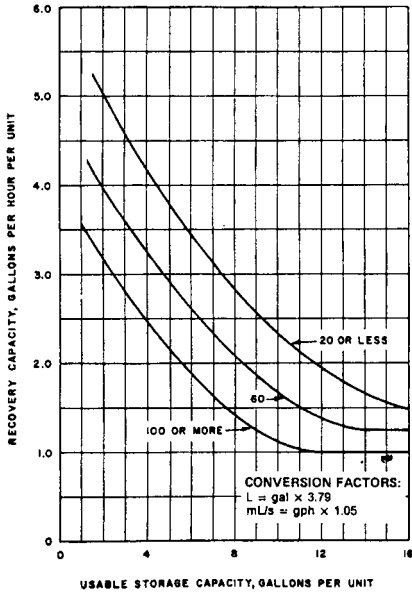

(c) Motels

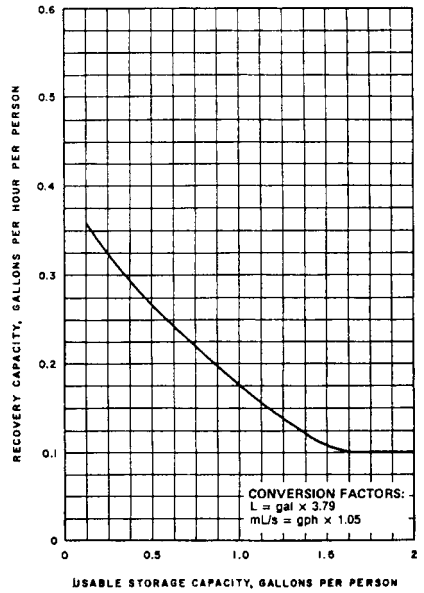

(d) Office Buildings

FIGURE 9.42 Relationship between recovery and storage capacity.

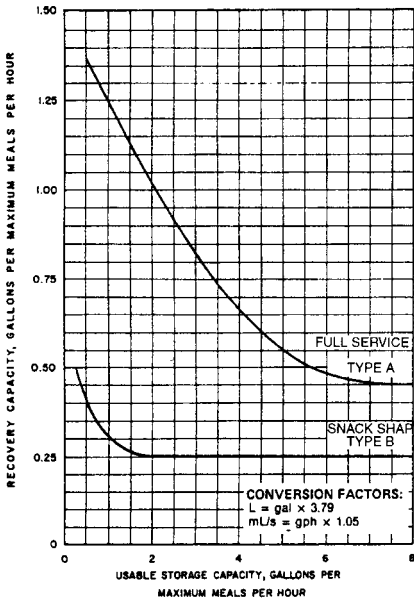

(c) Food Service

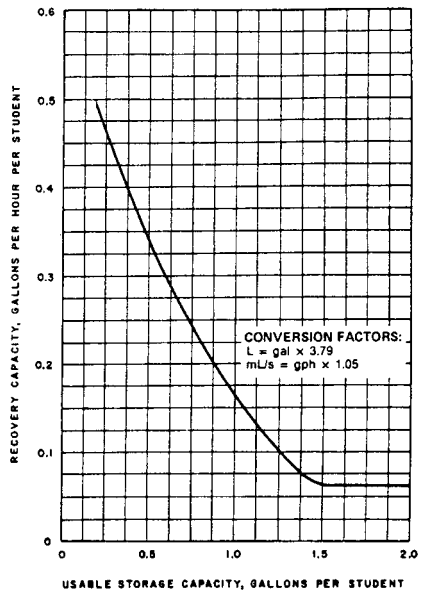

(f) Elementary Schools

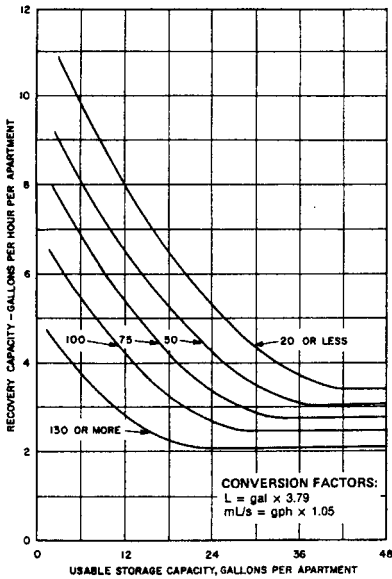

(g) Apartments

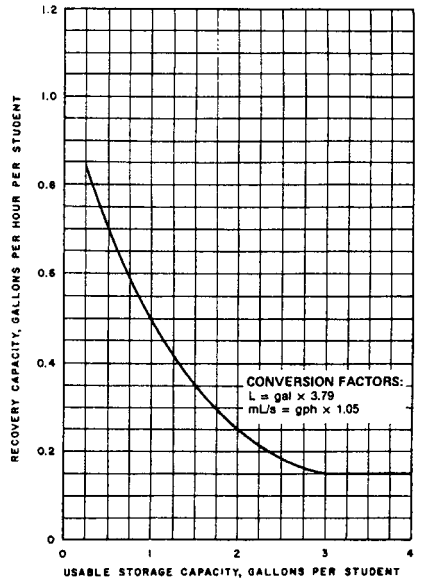

(h) High Schools

FIGURE 9.42 Relationship between recovery and storage capacity. (Continued)

**TABLE 9.36** Hot Water Demand for Various Facilities

Type of building	Maximum hour	Maximum day	Average day
Men's dormitories	3.8 gal/student	22.0 gal/student	13.1 gal/student
Women's dormitories	5.0 gal/student	26.5 gal/student	12.3 gal/student
Motels: number of units*			
20 or less	6.0 gal/unit	35.0 gal/unit	20.0 gal/unit
60	5.0 gal/unit	25.0 gal/unit	14.0 gal/unit
100 or more	4.0 gal/unit	15.0 gal/unit	10.0 gal/unit
Nursing homes	4.5 gal/bed	30.0 gal/bed	18.4 gal/bed
Office buildings	0.4 gal/person	2.0 gal/person	1.0 gal/person
Food-service establishments:			
Type A: Full-meal restaurants and cafeterias	1.5 gal/(max meals)/(h)	11.0 gal/(max meals)/(day)	2.4 gal/(avg meals)/(day)†
Type B: Drive-ins, grilles, luncheonettes, sandwich, and snack shops	0.7 gal/(max meals)/(h)	6.0 gal/(max meals)/(day)	0.7 gal/(avg meals)/(day)†
Apartment houses: no. of apartments:			
20 or less	12.0 gal/apt	80.0 gal/apt	42.0 gal/apt
50	10.0 gal/apt	73.0 gal/apt	40.0 gal/apt
75	8.5 gal/apt	66.0 gal/apt	38.0 gal/apt
100	7.0 gal/apt	60.0 gal/apt	37.0 gal/apt
130 or more	5.0 gal/apt	50.0 gal/apt	35.0 gal/apt
Elementary schools	0.6 gal/student	1.5 gal/student	0.6 gal/student†
Junior and senior high schools	1.0 gal/student	3.6 gal/student	1.8 gal/student†

\*Interpolate for intermediate values.

†Per day of operation.

Source: ASHRAE.

against the sizing figures previously calculated. It is also useful as a guide in estimating the total volume of hot water.

## **SAFETY AND PROTECTIVE DEVICES**

### **Temperature and Pressure Relief Valves**

The heating of water produces higher pressure in the hot water piping network and equipment than that in the cold water system. This pressure may exceed the rating of the various components if not relieved. To accomplish this three devices are used. *Temperature relief valves* discharge water from the system in the event water temperature is excessive; *pressure relief valves* discharge water from the system if the design pressure is exceeded; and *energy cutoff devices* are provided to stop the flow of fuel or a heating medium to the heater if the temperature or pressure value is exceeded anywhere in the system. It is common practice to combine the temperature and pressure relief into a single safety device.

The set temperature shall not exceed 210°F (99°C). The pressure shall be set at 5 percent lower than the pressure rating of the tank or heater. The relief valve discharge shall be routed to a safe place, visible to observe discharge, pitched down

and the same size as the relief valve discharge. No obstruction shall be placed in the line.

### **Thermostatic Mixing Valves**

It is common practice to provide a *thermostatic mixing valve* (TMV) on the hot water outlet of any hot water generator to prevent water that is too hot from being delivered to the facility. The TMV is a three-way mixing valve connected to the hot water supply, cold water supply, and the tempered water outlet supplying the facility. This device is generally considered mandatory on instantaneous heaters and strongly recommended on storage heaters.

Mixing valves are selected using the minimum flow rate (usually about 2 gpm), the maximum flow rate, and the pressure drop through the unit. If the range exceeds the capacity of a single unit, one small and one large TMV are installed in a parallel configuration. Use hot water DFUs (Table 9.33) and the modified Hunter curves (Figs. 9.40 and 9.41) to find the flow rate. To select a unit, consult manufacturers' catalogs, using the calculated figures.

### **Expansion Tanks**

Water expands when it is heated. When a storage tank system is used and there is a no-flow condition, the excess heat in the heating medium will continue to heat the water in the storage tank. If the water is prevented from expanding, it will cause the temperature and pressure relief valve to open. An expansion tank will safely accept that additional water volume and is highly recommended.

An expansion tank is a pressure tank partially filled with air that is compressed by the addition of water. The volume of the tank is determined by giving to the manufacturer the following information:

1. Storage tank size
2. Maximum system temperature
3. Cold water inlet temperature
4. System pressure
5. Relief valve set point (allowable working pressure). If less than 125 psi, deduct 10 percent from 125.

### **Double-Wall Shell and Tube Heat Exchangers**

A potential for contamination exists when the heating medium is at a higher pressure than the potable water being heated. Most codes now require the use of double-wall heat exchanger tubes with vented air space. Local codes must be checked for exact requirements.

## **SYSTEM DESIGN CONSIDERATIONS**

---

There are heat losses in the hot water system that will create additional load for the heater.

1. The standby heat loss in the storage tank and piping network must be added to the recovery rate of the heater. It is strongly recommended that the storage tank be insulated.

2. Because the introduction of colder water into a storage tank will lower the water temperature, the actual usable quantity of the water in the storage tank is only about 70 percent of the total quantity of water stored. This reduced volume must be considered when determining storage capacity.

3. To find the exact mixture of hot and cold water necessary to produce an intermediate temperature, refer to Table 9.37 for a mixture based on percent and Table 9.38 for a mixture based on volume.

4. Special conditions, occupants, or processes might affect the usage parameters.

The temperature rise in water heaters is generally based on an incoming water temperature of 40°F (4.4°C).

## **HOT WATER TEMPERATURE MAINTENANCE**

---

Generally accepted practice requires that hot water be delivered to a terminal point at utilization temperature within a reasonable period of time, usually 20 seconds. Some codes require that if the distance from a heater to the furthest fixture exceeds 50 ft (15 m) temperature maintenance is required.

### **Introduction**

When the hot water supply system is stagnant and not used, the temperature of the water in the piping system will lose heat to the ambient air during periods of no draw. In addition, when sizing the water heater and the hot water supply piping system, the lack of a proper hot water temperature maintenance system can seriously impact the required heater and pipe size. Water temperature is maintained by one of two methods.

1. *Circulating water system.* In this method the water in the hot water supply piping system is continuously circulated through the water heater when the temperature of the water falls below a predetermined set point.

2. *Electric heating cable.* This method consists of the installation of a self-current-regulating electric heating cable on the hot water distribution piping that is set to start operation when the temperature of the water falls below a predetermined set point.

### **Systems Description**

A circulating water system consists of a hot water circulating pump, a method to control this pump, an additional hot water recirculation pipe from the end of all branches or risers of the hot water supply piping and returning to the circulation pump, and an in-line flow balancing device on each return pipe branch to control the amount of water flowing through that specific branch (or riser) of the system. The methods utilized to create circulating systems are as varied as the imagination

**TABLE 9.37** Mixing of Hot and Cold Water on a Percentage Basis\*

Temperature of mixture, °F	Temperature of cold water, °F																	
	40	50	60	70	80	90	40	50	60	70	80	90	40	50	60	70	80	90
	210° hot water						200° hot water						190° hot water					
200	94*	94	93	93	92	92	—	—	—	—	—	—	—	—	—	—	—	—
190	88	88	87	86	85	83	94	93	93	92	92	91	—	—	—	—	—	—
180	82	81	80	79	76	75	88	87	86	85	83	82	93	93	92	92	91	90
170	76	75	73	71	69	67	81	80	79	76	75	73	87	86	85	83	82	80
160	71	69	67	65	62	58	75	73	71	69	67	64	80	79	76	75	73	70
150	65	62	60	57	54	50	69	67	65	62	58	55	73	71	69	67	64	60
140	59	56	53	50	46	42	62	60	57	54	50	45	67	65	62	58	55	50
130	53	50	46	43	38	33	56	53	50	46	42	36	60	57	54	50	45	40
120	47	44	40	36	31	25	50	46	43	38	33	27	53	50	46	42	36	30
110	41	38	33	29	23	17	44	40	36	31	25	18	46	43	38	33	27	20
100	36	31	26	21	15	10	38	33	29	23	17	9	40	36	31	25	18	10
	180° hot water						170° hot water						160° hot water					
170	93	92	92	91	90	89	—	—	—	—	—	—	—	—	—	—	—	—
160	86	85	83	82	80	78	92	92	91	90	89	88	—	—	—	—	—	—
150	79	76	75	73	70	67	85	83	82	80	78	75	92	91	90	89	88	86
140	71	69	67	64	60	56	76	75	73	70	67	63	83	82	80	78	75	71
130	65	62	58	55	50	44	69	67	64	60	56	50	75	73	70	67	63	57
120	57	54	50	45	40	33	62	58	55	50	44	38	67	64	60	56	50	43
110	50	46	42	36	30	21	54	50	45	40	33	25	58	55	50	44	38	29
100	43	38	33	27	20	11	46	42	36	30	21	12	50	45	40	33	25	14
	150° hot water						140° hot water						130° hot water					
140	91	90	89	88	86	83	—	—	—	—	—	—	—	—	—	—	—	—
130	82	80	78	75	71	67	90	89	88	86	83	80	—	—	—	—	—	—
120	73	70	67	63	57	50	80	78	75	71	67	60	89	88	86	83	80	75
110	64	60	56	50	43	33	70	67	63	57	50	40	78	75	71	67	60	50
100	55	50	44	38	29	17	60	56	50	43	33	20	67	63	57	50	40	25

\*Percentage of mixture which is hot water.

Source: Air Conditioning, Heating, and Ventilating, August 1958.

**TABLE 9.38** Mixing of Hot and Cold Water on a Ratio of Volume to Volume

Temperature of mixture, °F	Temperature of cold water, °F																	
	40	50	60	70	80	90	40	50	60	70	80	90	40	50	60	70	80	90
	210° hot water						200° hot water						190° hot water					
200	16.0*	15.0	14.0	13.0	12.0	11.0	—	—	—	—	—	—	—	—	—	—	—	—
190	7.5	7.0	6.5	6.0	5.5	5.0	15.0	14.0	13.0	12.0	11.0	10.0	—	—	—	—	—	—
180	4.7	4.3	4.0	3.7	3.3	3.0	7.0	6.5	6.0	5.5	5.0	4.5	14.0	13.0	12.0	11.0	10.0	9.0
170	3.3	3.0	2.8	2.5	2.3	2.0	4.3	4.0	3.7	3.3	3.0	2.7	6.5	6.0	5.5	5.0	4.5	4.0
160	2.4	2.2	2.0	1.8	1.6	1.4	3.0	2.8	2.5	2.3	2.0	1.8	4.0	3.7	3.3	3.0	2.7	2.3
150	1.8	1.7	1.5	1.3	1.2	1.0	2.2	2.0	1.8	1.6	1.4	1.2	2.8	2.5	2.3	2.0	1.8	1.5
140	1.4	1.3	1.1	1.0	0.9	0.7	1.7	1.5	1.3	1.2	1.0	0.8	2.0	1.8	1.6	1.4	1.2	1.0
130	1.1	1.0	0.9	0.8	0.6	0.5	1.3	1.1	1.0	0.9	0.7	0.6	1.5	1.3	1.2	1.0	0.8	0.7
120	0.9	0.8	0.7	0.6	0.4	0.3	1.0	0.9	0.8	0.6	0.5	0.4	1.1	1.0	0.9	0.7	0.6	0.4
110	0.7	0.6	0.5	0.4	0.3	0.2	0.8	0.7	0.6	0.4	0.3	0.2	0.9	0.8	0.6	0.5	0.4	0.3
100	0.6	0.5	0.4	0.3	0.2	0.1	0.6	0.5	0.4	0.3	0.2	0.1	0.7	0.6	0.4	0.3	0.2	0.1
	180° hot water						170° hot water						160° hot water					
170	13.0	12.0	11.0	10.0	9.0	8.0	—	—	—	—	—	—	—	—	—	—	—	—
160	6.0	5.5	5.0	4.5	4.0	3.5	12.0	11.0	10.0	9.0	8.0	7.0	—	—	—	—	—	—
150	3.7	3.3	3.0	2.7	2.3	2.0	5.5	5.0	4.5	4.0	3.5	3.0	11.0	10.0	9.0	8.0	7.0	6.0
140	2.5	2.3	2.0	1.8	1.5	1.3	3.3	3.0	2.7	2.3	2.0	1.7	5.0	4.5	4.0	3.5	3.0	2.5
130	1.8	1.6	1.4	1.2	1.0	0.8	2.3	2.0	1.8	1.5	1.3	1.0	3.0	2.7	2.3	2.0	1.7	1.3
120	1.3	1.2	1.0	0.8	0.7	0.5	1.6	1.4	1.2	1.0	0.8	0.6	2.0	1.8	1.5	1.3	1.0	0.8
110	1.0	0.9	0.7	0.6	0.4	0.3	1.2	1.0	0.8	0.7	0.5	0.3	1.4	1.2	1.0	0.8	0.6	0.4
100	0.8	0.6	0.5	0.4	0.3	0.1	0.9	0.7	0.6	0.4	0.3	0.1	1.0	0.8	0.7	0.5	0.3	0.2
	150° hot water						140° hot water						130° hot water					
140	10.0	9.0	8.0	7.0	6.0	5.0	—	—	—	—	—	—	—	—	—	—	—	—
130	4.5	4.0	3.5	3.0	2.5	2.0	9.0	8.0	7.0	6.0	5.0	4.0	—	—	—	—	—	—
120	2.7	2.3	2.0	1.7	1.3	1.0	4.0	3.5	3.0	2.5	2.0	1.5	8.0	7.0	6.0	5.0	4.0	3.0
110	1.8	1.5	1.3	1.0	1.8	0.5	2.3	2.0	1.7	1.3	1.0	0.7	3.5	3.0	2.5	2.0	1.5	1.0
100	1.2	1.0	0.8	0.6	0.4	0.2	1.5	1.3	1.0	0.8	0.5	0.3	2.0	1.7	1.3	1.0	0.7	0.3

\*Number of gallons of hot water which, when mixed with 1 gal of cold water, produces a given mixture temperature.

of the engineer. Two basic circulating system diagrams are shown in Figs. 9.43 and 9.44.

The electric heating cable system consists of a self regulating cable installed directly onto the hot water distribution pipe. This cable is capable of gradually adjusting the amount of electrical current (and therefore the amount of heat produced) based on the temperature of the water in the pipe. When the temperature of the water is adequate, no electrical current will be required. No recirculation line is required.

Point of use water heaters are practical where there is a remote or very seldom used fixture that does not justify a long run of piping. They are cost effective because a hot water and hot water circulation line do not have to be installed. A point of use heater is illustrated in Fig. 9.45.

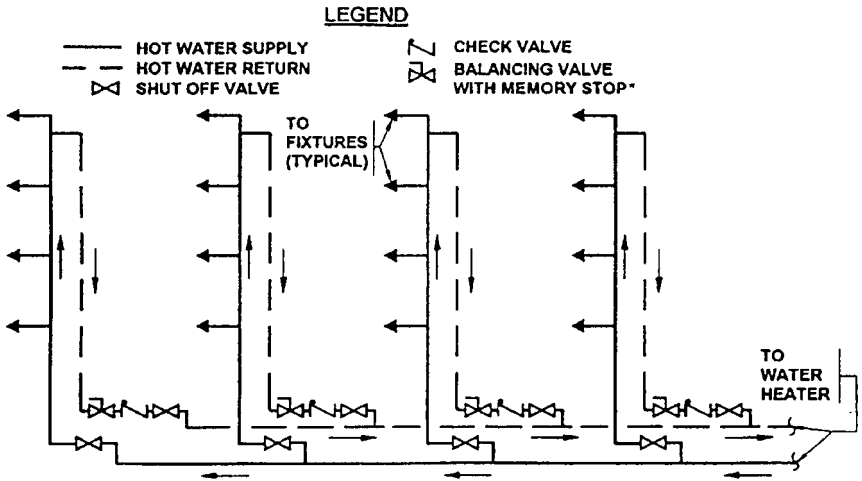

FIGURE 9.43 Upfeed hot water system with heater at bottom of system.

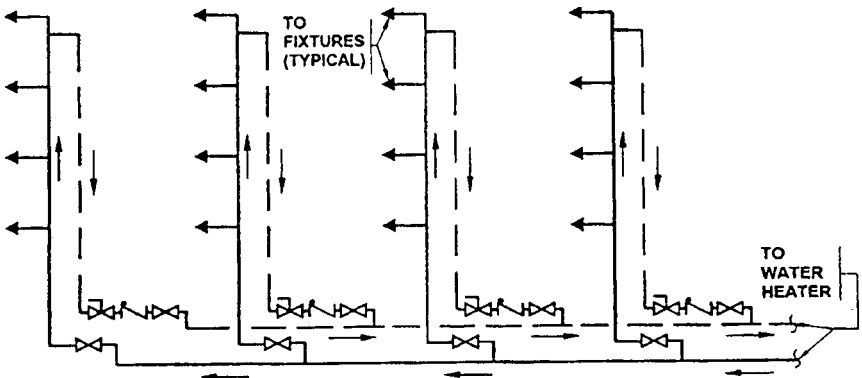

FIGURE 9.44 Upfeed hot water system with heater at bottom of system.

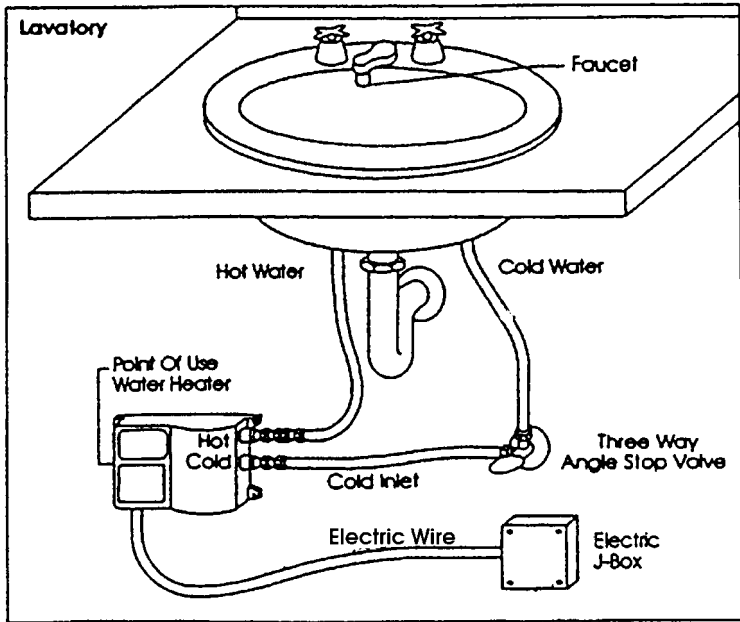

FIGURE 9.45 Point of use water heater.

## CIRCULATING WATER SYSTEM

### Component Description

**Hot Water Circulating Pumps.** Hot water circulating pumps are centrifugal type, available either as in-line (for smaller systems) or base-mounted units for larger systems. In-line pumps are the most commonly used. Because of the corrosiveness of hot water, the pump internals should be bronze or brass. Conventional iron body pumps are not recommended.

**Pump Control Methods.** There are two methods of controlling the starting of the circulating pump: manual or thermostatically operated. There is a difference of opinion regarding which is of greater benefit.

The manual control has the system running continuously when the pump is started by turning the power on or off. This system is of greatest benefit when the system is not used for relatively long periods of time, such as at night in office buildings, over weekends and for extended shut-downs, such as planned facility vacations or maintenance down-time.

Thermostatic operation uses a device to start the pump when the temperature of the water at the water heater falls below the set point of the system based on the allowable temperature drop, usually 130°F (52°C) in a 140°F (60°C) system, which equates to a 10°F differential (5.5°C  $\Delta T$ ). The thermostat is usually installed in the return piping using an oversized tee and nipple.

**Flow Balancing Devices.** It is extremely important that the circulated hot water system be balanced for its specified flows, including all of the various individual loops within the circulated system. If they are not, water will tend to short-circuit through the closest loops and create high velocities in the piping system, and this will result in people complaining about the long delays in getting hot water at the most remote loops. Because of the problems inherent in manually balancing hot water circulation systems, many professionals have incorporated factory preset flow control devices into their hot water systems. While the initial cost of the device is higher than a manual balancing valve, the present devices are normally less expensive when field labor cost to balance the entire hot water system is included. However, with the use of present flow control devices, the plumbing designer has to be far more accurate in selecting the capacity of the control device, as there is no field adjustment available. Therefore, if more or less hot water return flow is needed by the actual field installation, a new flow control device must be installed with the old flow control device being removed and junked. Following are the various flow control devices generally used.

1. *Fixed orifice.* These are devices that can be bought for the specific flow rates and simply inserted into the hot water return piping system. However, extreme care should be provided to be able to remove these devices and clean them out, as they may become clogged due to debris in the water. Therefore, it is recommended that a strainer with a blowdown valve be placed ahead of each of these devices or a strainer with a fine mesh screen be installed on the main water line coming into the building. Also, a shutoff valve should be installed ahead of and after these valves so that the entire loop does not have to be drained to service these devices.

2. *Factory preset automatic flow control valves.* The same admonition about strainers also applies to the installation of these devices.

3. *Ball valves.* These are valves that can be used to determine the flow rate by reading the pressure drop across the valve by some of the various devices that are available.

4. *Ball valves with memory stops.* These can be adjusted to the proper setting by use of temperature measuring devices inserted in the piping system or by the use of snap-on flow sensing devices that will indicate the flow rate in the pipe line.

**Pump Control Methods.** The starting of the circulating pump could be controlled either manually or by means of a thermostat set to start the pump when the temperature of the water in the pipe falls below the lower set point temperature of the system.

### **System Design Criteria**

The following criteria shall be established for the design of a circulated water system:

1. Maximum length of uncirculated supply pipe
2. Amount of time allowed for proper temperature water to reach the terminal fixture
3. Allowable temperature drop of hot water supply to the terminal fixture

4. The flow rate to be circulated
5. The hot water circulation system pipe size
6. Velocity in the recirculation system piping

**Maximum Length of Uncirculated Supply Pipe.** Currently, due to not only energy conservation but to water shortages in numerous areas of the country, the wasting of water due to the long delay in obtaining hot water at the fixtures has become a critical aspect. Therefore, to reduce significantly the wasting of cooled hot water, the acceptable distance permitted for uncirculated, dead-end branches to plumbing fixtures must be kept to a minimum. These allowable distance for uncirculated, dead-end branches are a trade-off between the energy utilized in circulating the hot water (or keeping the water hot by other means) and the cost of the insulation versus the cost of the energy to heat the excess cold water makeup, the cost of wasted potable water, and extra sewer surcharge costs. There are some codes that set a maximum dead end hot water supply branch length to 50 ft (15 m) in length.

**Acceptable Time Limits for Hot Water to Reach Terminal Fixtures.** When designing the hot water system, the hot water must reach fixtures within acceptable time limits. For other than very infrequently used fixtures, such as industrial facilities or certain fixtures in office buildings, etc., a delay of up to ten seconds is normally considered acceptable for most residential or public fixtures in office building applications. A delay of 11 to 30 seconds is marginal but acceptable, and beyond 31 seconds is normally considered unacceptable and a significant wastage of water and energy. A maximum delay of 20 seconds is a generally accepted figure for most applications.

This normally means that the hot water circulated or heated by other means should be brought to within a maximum distance of 20 ft (7 m) from all the plumbing fixtures requiring hot water. The design professional may want to stay under this length limitation because the actual installation in the field may be slightly different than what the engineer designed, and there may be a longer delay caused by either routing of pipe or other problems. Furthermore, with today's low fixture flow rates mandated by national and local requirements, it takes considerably longer to obtain hot water from non-circulated hot water lines than it did in the past when fixtures had greater flow rates. In addition, when there is a long time delay in obtaining hot water at the fixture, a significant wastage of potable water results since the cooled hot water is wasted.

**Allowable System Temperature Drop.** The greater the design temperature drop across the system, the less water is required to be circulated, thereby saving on pumping costs. However, the 20°F (11°C) temperature drop previously used is now considered excessive. If the domestic hot water supply starts out at 140°F (60°C) with a 20°F (11°C) temperature drop across the supply system, the fixtures near the end of the circulating loop will only be provided with hot water supply of 120°F (52°C), which is considered too low a temperature. Furthermore, with a hot water supply delivery temperature of only 120°F (52°C) instead of 140°F (60°C), the fixtures will use a greater volume of hot water to get to the desired blended water temperature.

Therefore, the system temperature drop should be in the magnitude of 10°F (6°C). So, if the hot water system starts out at 140°F (60°C), 130°F (54°C) would be the coolest hot water supply temperature provided by the hot water supply system. This would still give good operation of the hot water system.

**Circulating Water Flow Rate.** The flow rate of circulating water is a function of the allowable system temperature drop selected by the design professional and the actual heat loss through the hot water supply and recirculating piping. The most accurate method of calculating the heat loss through the piping system into a gpm equivalent is to relate it as a function of temperature drop. This relationship is derived from the following formula, and is tabulated in Table 9.39.

$$Q = [SH \times W] [60 \text{ (min/h)}] [\Delta T] \quad (9.3)$$

where  $Q$  = Quantity (flow rate) of recirculated water, in gpm

SH = specific heat of water, equal to 1

W = weight of water, 8.33 lbs/gal

$\Delta T$  = selected system temperature drop

There are two very general and arbitrary “rules of thumb” that are used for small, uncomplicated systems that experience has proven successful. One is to allow  $\frac{1}{2}$  gpm (2.0 L) for each 20–25 fixtures. Another figure, when larger systems with a number of risers or branches are present, is to allow  $\frac{1}{2}$  gpm (2.0 L) for each smaller riser or branch and 1 gpm (4.0 L) for each intermediate and larger riser or branch. It is highly recommended that scientific methods be used to calculate the flow rate rather than rules of thumb.

**Hot Water Circulation System Pipe Size.** The selected size of the recirculation piping is an iterative one, depending on the flow rate and an acceptable friction loss in the piping network. The higher the friction loss, the more horsepower the circulating pump will require. As a general starting point, a single branch recirculation line shall be a minimum size of  $\frac{1}{2}$  in (DN 15). For multiple-branch systems when recirculating branches combine, the size should be one half of the hot water supply pipe. These sizes are starting point that could be adjusted as actual system design and the selection of the circulating pump progresses.

**Velocity of Circulating Water.** For copper piping systems, it is important that the circulated hot water supply and hot water return piping be sized so that the water is moving at a low velocity. For copper piping, the recommended maximum rate is 8 ft per second (2.6 ms).

## System and Component Sizing Procedure

The procedure for sizing the system components and entire piping network is as follows.

**TABLE 9.39** Relationship of Temperature Drop to BTU/GPM

Temperature Drop	BTU/GPM Relationship
5°	2,500 B/h = 1 GPM
10°	5,000 B/h = 1 GPM
15°	7,500 B/h = 1 GPM
20°	10,000 B/h = 1 GPM

1. Layout the system and measure the equivalent pipe run for the entire hot water supply and return piping network.
2. Size the recirculation piping system. This assumes that the hot water supply piping has been previously sized.
3. Determine the system temperature drop.
4. Calculate the system heat loss.
5. Calculate the return system flow rate.
6. Calculate the friction loss in the entire hot water supply and return piping. Adjust the return system pipe size as required to reflect velocity considerations and pump head restrictions.
7. Size the circulating pump based on calculations from 5 and 6.

**Layout the System.** Make a piping diagram of the hot water distribution system showing hot water piping and approximate lengths.

**Size the Return System Piping.** Use the sizing method previously discussed under system design criteria to preliminarily size the return piping. This will give a starting point for the remaining calculations.

**Select the System Temperature Drop.** The recommended drop should be 10°F (6°C). Use judgment when using another figure.

**Calculate the System Heat Loss.** Tabulate the total system heat losses (heater and piping) in BTUs per hour. For piping, measure the length and size of pipe in the piping diagram; the total hourly heat loss in only the longest length of hot water supply and return system should be calculated. Enter Table 9.40 with the insulation thickness and pipe size for piping heat loss, and Table 9.41 for approximate tank heat loss. Add these figures together and arrive at a total system heat loss in BTU/h.

**TABLE 9.40** BTU/h Heat Loss per ft for Tubing & Steel Pipe\*

Pipe size (in)	Pipe size DN	Insulated steel pipe schedule 40	Insulated copper tube type L	Non-insulated steel pipe	Non-insulated copper tube
1/2"	15	10.0	8.2	4.0	2,3
3/4"	20	11.5	10.3	5.0	3,0
1"	25	13.5	12.0	6,0	4,0
1-1/4"	32	16.0	13.9	7,5	4,5
1-1/2"	40	18.6	15.8	8,5	5,5
2"	50	20.5	20.0	11,0	6,5
2-1/2"	65	25.0	22.6	12,0	8,0
3"	80	31.0	26.7	15,0	9,5
4"	100	35.0	33.8	19,0	12,0
5"	125	50.0		22,5	
6"	150	65.0		26,0	

\*Based on 140°F hw and 70°F ambient air, 1/2 in fiberglass insulation. 1 ft = 0.3 m.

**TABLE 9.41** Heat Loss from Various Size Tanks with Various Insulation Thicknesses

Insulation thickness (in)	Tank size (gal)	Approx. energy loss from tank at hot water temperature 140°F (BTU/h)*
1	50	468
1	100	736
2	250	759
3	500	759
3	1000	1273

Insulation thickness (mm)	Tank size (L)	Approx. energy loss from tank at hot water temperature 60°C (W) <sup>a</sup>
25.4	200	137
25.4	400	216
50.8	1000	222
76.2	2000	373
76.2	4000	

\*For unfired tanks, federal standards limit the loss to no more than 1.9 W/m<sup>2</sup> of tank surface.

**Source:** From Sheet Metal and Air Conditioning Contractors National Association (SMACNA) Table 2 data.

**Calculate the System Flow Rate.** The formula to find the system flow rate in gpm is:

$$\frac{\text{total system heat loss}}{\text{gpm relationship from Table 9.39}} = \text{system flow rate in gpm} \quad (9.4)$$

As an example, if the total heat loss is 8,500 BTU/hr and the  $\Delta T$  is 5°F.

$$\text{gpm} = \frac{8500}{2500} \text{ gpm} = 3.4$$

Once a hot water return required flow rate (in gpm) is established, then the size of the hot water return piping system should be adjusted based on piping flow rate, velocity and the available pump head obtained from a manufacturers catalog. Select the most cost-effective solution.

**Size the Circulating Pump.** The hot water return circulating pump is selected based on the required gpm flow rate previously calculated and system friction loss. The pump head is calculated using the friction loss only (the flow rate through the single longest equivalent length of pipe using standard references such as Cameron's Hydraulic Data or other proprietary calculators available from major manufacturers). This friction loss must include that occurring in the entire hot water piping system. The reason for this is that the hot water return system flow is only needed in order to keep the system up to temperature when there is no flow in the hot water supply piping. Therefore, when hot water is in use, there is usually

**TABLE 9.42** Fixture and Equipment Mounting Heights

Component	Children	Standard	ADA compliant	
LUC	13	14–15	17–19	FV of 26" for PS K-6 29" for adults
BIDET		15		
UR	18	24	17	To top of lip
UR FV			44	
LAV	2.4	36	33–36	
SK	24	36	33–36	
SS		26		
MOP SK		36		
SPOUT				
BT		14–17	14–17	
BT Handles		16	16	Above top of BT
WHORLPOOL		18–24		
SH HEAD	54–56	72–84		
SH HANDLES	45	48	36	
DF, EWC	24	40	34–36	To spout
ES HEAD		88	82–96	Bottom of head
EW		42	33	
ES		78	48–54	Bottom of pull
HB		24		
WH		26		
FAI		26		
FIRE EXT		60		Top of Extinguisher
SIAMESE		26		
HOSE CAB		74		Top of Cabinet
Hose Value		70		
Fire Dept Value		48		
Spir Test		84		

All dimensions are in inches.

Dimensions are from floor or grade to and of component.

Plumbing fixture dimensions are to the rim or top of fixture.

sufficient flow in the hot water supply piping to normally keep the system hot water supply piping up to temperature even without the flow in the hot water return piping.

The principal variance of this concept of ignoring the friction in the hot water supply piping is where the hot water return piping is connected to a relatively small hot water supply line. By relatively small is meant a line that is less than one pipe size larger than that to which the hot water return line is connected. The problem that occurs when the hot water supply line is too small for the hot water return line is that the hot water supply line will add friction head to the hot water circulating pump, and additionally the hot water circulating pump flow rate may deprive the plumbing fixtures on this hot water supply line from obtaining their required flow. Therefore, the hot water supply line supplying each hot water return piping connection point should be increased to eliminate this potential problem.

It is quite common for a plumbing designer to have a wrong preliminary assumption as to the size of the hot water return line to establish the initial heat loss figure. However, after establishing the required hot water return flow rate (gpm), it

is determined that the hot water return line must be larger, the plumbing designer should simply recheck the calculations using the new data based on the correct pipe sizing and verify that all the rest of the calculations are correct.

In selecting the hot water circulating pump's head, be sure that only the restrictions placed on the circulating pump are calculated and do not include any static heads where none exist. For example, in Fig. 1 the hot water circulating pump only has to overcome the friction in the piping, but not the static head of pumping the water up to the fixtures. This is because in a closed system the entire system is in equilibrium; therefore, static head loss is offset by the static head gain when the hot water return piping drops down.

### **System Design Considerations**

The following are some of the potential problems in hot water circulated systems that must be addressed by the plumbing system designer.

1. It is extremely important in circulated systems that shutoff valves be provided on every circulation branch in order to isolate the entire circulated loop, so that if individual fixtures need modification, that piping loop can be isolated out of the entire system and the entire hot water system does not have to be shut off and drained.

2. The means for ensuring hot water system balancing requires that the hot water return system be provided with either a separate balancing valve in addition to the shutoff valve or, if the balancing valve is also used as the shutoff valve, the balancing valve should have a memory stop. With a memory stop on the valve, the plumbers can return the system to its balanced position without having the whole piping system unbalanced when they leave. As previously indicated, unbalanced hot water systems create serious problems.

3. Provide a check valve on each hot water return line when it joins other hot water return lines. This is to ensure that a plumbing fixture does not draw hot water return water instead of hot water supply water due to pressure drops in the various piping systems.

4. Keep the time delay in obtaining hot water at the fixtures to within the time parameters given previously to eliminate unhappy users and occupants of the hot water system and to prevent wasting of water by having it run for long periods of time.

5. For plumbing fixtures that are remote from the circulating system and/or plumbing fixtures that are infrequently used, the plumbing designer may wish to consider a point-of-use water heater near that fixture rather than extend the hot water system to circulate to a point near the remote fixtures.

6. When a central mixing valve is used to produce temperate hot water for a facility, the hot water return piping arrangement shown in Fig. 9.46 is recommended in order to eliminate fluctuations in temperature and pressure.

7. Do not have the return piping from a riser as the highest connection. If this is done, air binding will result.

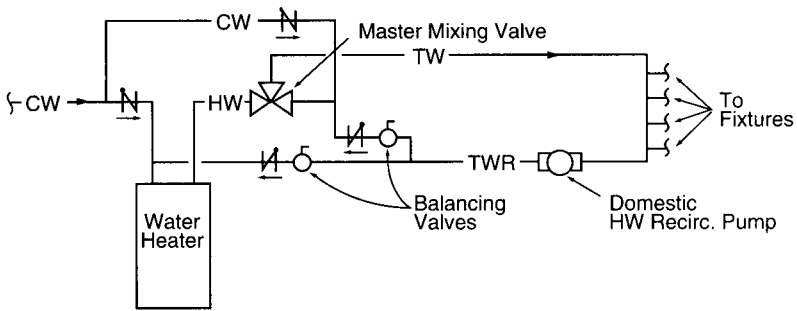

FIGURE 9.46 Schematic diagram of hot water return system.

## ELECTRIC HEATING CABLE

### General

Because of the problems of balancing circulated hot water systems and the loss of energy in the return piping, the use of electric heating cable has come into its own. In many installations, this concept provides the instant hot water required at all fixtures. This is because heat from the electric cable is put on the hot water lines right up to the fixture connection, so the hot water supply water is always kept up to temperature. The electric trace heating of domestic hot water systems is an outgrowth of snow melting and industrial trace heating utilized on specific piping lines to prevent freezing, etc., which have been used successfully for many years. The electric heat cable method can also be used in conjunction with a piped hot water circulated system with only dead-end branches to the plumbing fixtures provided with cable heat so the two systems are not mutually exclusive.

The electric heating system has the following advantages:

1. Allows a possible reduction in the heating of water to only the end-user-required temperature rather than higher to allow for drop in temperature of the water
2. Eliminates the hot water return piping and pump
3. Power is drawn only when the temperature of the water is low, and then only in proportion to the actual water temperature.

### Component Description

The basic component of this system is an electric heating cable attached directly to the hot water piping system under the insulation. This cable is called self-regulating, which allows gradual and adjustable changes to the current in response to the gradual cooling of the water in the pipe. When the hot water supply temperature is adequate, there is no current flow. The adjustment is automatic and does not require a thermostat.

Other components of the heater cable system are power connections from the cable to the electrical power supply, splice and tee connections to the cable and end seals of the cable to protect the end of the cable from damage and prevent exposure to live electric wires.

Since it is not possible for an entire building to be heated on one electrical circuit, the system shall be divided into separate circuits, each controlled by a separate thermostat and having a separate circuit breaker.

### **System Design Criteria and Sizing**

The following criteria shall be established for the design of a circulated water system.

1. Determine the extent and layout of the hot water circulating piping.
2. Select the system design temperature. This is usually 140°F (60°C).
3. Select the appropriate cable from the manufacturers catalog. This will also establish the current draw for the cable.
4. Determine the electrical requirements. Each different type of cable has a maximum allowable circuit length. Based on electrical requirements for the largest circuit breaker size (usually 30 amps), determine the number of circuits by dividing the maximum allowable circuit length into the total feet of cable. Maximum cable length should not be exceeded.
5. If the available voltage is not the same as the cable, a transformer must be provided.
6. Some larger size pipes require more than one cable. Refer to manufacturers recommendations.

### ***System Design Considerations***

1. In general, separate circuits should be provided for the following logical segments:
  - a. Each main and long riser
  - b. Each wing or building section
  - c. Each pressure zone
2. Locate power connections near electrical panels to minimize the electrical costs.
3. Locate tees in accessible locations to make trouble-shooting and maintenance easy.