CHAPTER B11

RUBBER-LINED PIPING SYSTEMS

Richard Lewis

*Executive Vice President
Blair Rubber Company
Akron, Ohio*

David Jentsch

*General Manager
Blair Rubber Company
Akron, Ohio*

INTRODUCTION

This chapter is written to provide the reader with information about rubber-lined piping, including engineering applications and installation details. Rubber lining has been used for decades to protect metal pipe from corrosion. Rubber lining has also demonstrated its superiority in protecting piping against abrasion and is used extensively in abrasive service applications.

Rubber-lined piping has been used for all types of chemical environments (acids and basic solutions) that range from a pH of 1 to 14, and with temperatures ranging from 50 to 220°F (10 to 104°C). Applications include such numerous services as cationic/anionic water-treatment systems; piping in plants that manufacture chemicals, including those producing hydrochloric acid, phosphoric acid, chlorine, and titanium oxide; and slurry pipe lining for both corrosive and abrasive conditions, such as in power plant and mining operations. The mining applications include transport of copper, iron and uranium ore, and other rare minerals mined and piped to overland plants and to tailing or settling ponds.

Rubber linings form an impermeable barrier to many gases and liquids. They can only provide protection, however, if the pipe is properly fabricated and the type of rubber lining is suitable for the chemical service. Many types of rubber linings exist. The correct type of rubber lining must be matched with the appropriate service conditions. This selection is determined by the rubber lining manufacturer.

PIPE FABRICATION REQUIREMENTS

Metal Specifications

Pipe intended to be lined with rubber linings should be fabricated such that all joints can be continuously welded and ground smooth. Any special requirements specified by an engineering company or end user shall be agreed upon by all parties prior to pipe fabrication. An overview of these specifications is provided in the following subsections.

Material

The surfaces are to be free of galvanizing or other plating, oil, and grease. The surface must also be free of scale and other foreign material not readily removed by sandblasting or shotblast. Castings, when specified, are to be smooth and free of porosity, defects, sand or blow holes, and other imperfections.

Pipe is to be seam-welded or seamless steel pipe unless otherwise specified. Wall gauge is to be specified if not shown or called for on purchase orders or drawings.

Flanges shall be flat-faced, Class 150 forged steel slip-on, weld neck, or boiler plate. Raised face flanges shall not be used. Class 125 cast-iron flanges or cast-iron pipe are not recommended for use with rubber lining. If customers insist on using cast-iron pipe and flanges, they do so at their own risk. Cast-iron is porous, which results in the formation of minute air blisters between the rubber and the metal. These air blisters expand during the steam cure, causing rubber-to-metal bond failure. A defect in the lining that looks like a blister is known as a *blow*.

Flanges on opposite ends of pipe are to have their bolt holes in exact alignment, unless otherwise specified. Pipe ends at the flange face are to be continuously welded and ground smooth. Rough burrs are to be removed.

When cast-steel domes and fittings are specified, they shall be free from porosity, sand holes, and other foreign material.

TABLE B11.1 Typical Lengths for Straight Pipe

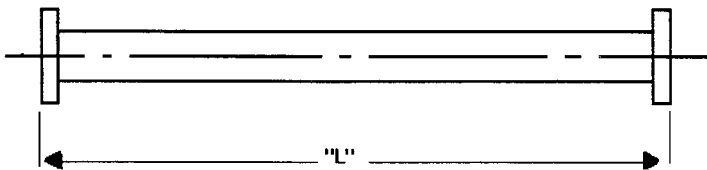

National pipe size NPS (DN)	2 (50)	3 (80)	4 (100)	6 (150)	8 (200)	10–42 (250–1050)
Maximum recommended length feet (meters)	6 (2)	10 (3)	20 (6)	30 (9)	40 (12)	40 (12)

General notes: "L" denotes maximum overall length

Pipe Fabrication Design Criteria

Unless otherwise specified, dimensions for pipe are end to end. For projecting fittings the dimensions are measured from the centerline to the outside surface facing of the fitting, nozzle, or flange. The tolerances shown below apply to overall pipe length dimensions, when such tolerances are specified on the drawings.

- Straight Pipe NPS 24 (DN 600) or less Plus or minus 1/16 in (1.5 mm)
- Straight Pipe over NPS 24 (DN 600) Plus or minus 1/8 in (3.2 mm)
- Flange Gaskets Plus or minus 1/16 in (1.5 mm)

Tables B11.1 through B11.4 provide the maximum length dimensions in designing runs of pipe that will allow the rubber lining applicator to install the lining. The maximum length dimensions shown include flange length; however, pipe may or may not have flanged ends.

TABLE B11.2 Pipe with Standard 45° Elbow Limitations

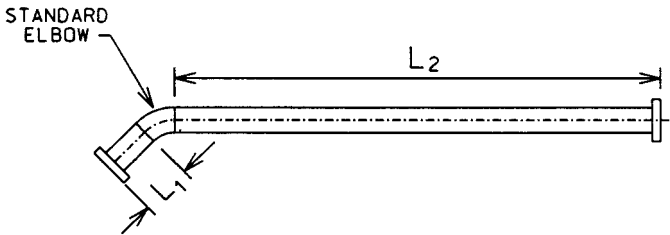

Pipe size NPS (DN)	L ₁ maximum in (mm)	L ₂ maximum ft (mm)
2 (50)	2 (51)	6 (1829)
3 (80)	4 (102)	6 (1829)
4 (100)	5 (127)	8 (2438)
6 (150)	8 (203)	10 (3048)
8 (200)	12 (305)	14 (4267)
10 (250)	12 (305)	14 (4267)
12 (300)	18 (457)	14 (4267)
14 (350)	24 (610)	14 (4267)
16 (400)	24 (610)	14 (4267)
18 (450)	24 (610)	20 (6096)
20 (500)	24 (610)	20 (6096)
24 (600)	60 (1524)	30 (9144)

TABLE B11.3 Pipe with Standard 90° Elbow Limitations

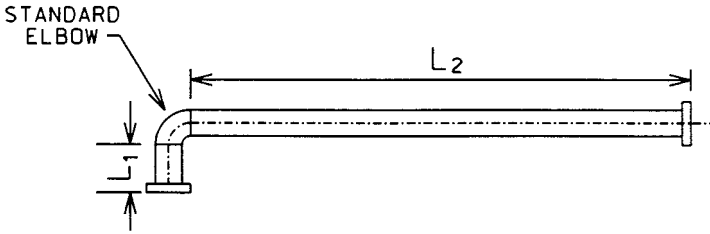

Pipe size NPS (DN)	L ₁ maximum in (mm)	L ₂ maximum ft (mm)
2 (50)	2 (51)	4 (1219)
3 (80)	6 (152)	4 (1219)
4 (100)	6 (152)	4 (1219)
6 (150)	6 (152)	6 (1829)
8 (200)	18 (457)	10 (3048)
10 (250)	18 (457)	10 (3048)
12 (300)	24 (610)	10 (3048)
14 (350)	30 (762)	10 (3048)
16 (400)	36 (914)	10 (3048)
18 (450)	36 (914)	10 (3048)
20 (500)	36 (914)	12 (3658)
24 (600)	48 (1219)	30 (9144)

Construction

The necessary bolts, nuts, and washers to complete any assembly are to be furnished by the pipe supplier or fabricator; unless otherwise specified.

The pipe is designed to allow the rubber lining applicator to perform the task of putting the rubber sheet stock on the inside of the pipe. Tables B11.1 through B11.4 show that the smallest pipe size which can be lined is NPS 2 (DN 50); however, NPS 1 nozzles can be lined per the following specifications:

1. Maximum length of nozzle is NPS 1 (DN 25)
2. Maximum thickness of rubber is 3/8 in (3 mm)
3. Maximum distance from end of pipe is 18 in (450 mm)
4. Nozzle is attached to a minimum of NPS 6 (DN 150) pipe

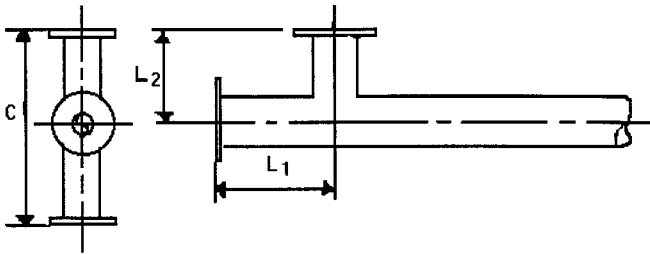
TABLE B11.4 Header Branch Limitations: Branches Near End of Fabricated Piece

IF BRANCH CONNS. ARE REQ. IN OPPOSITE DIRECTIONS OFF MAIN RUN
DIM. 'C' SHALL NOT EXCEED 3'-0" (914 mm)

Header size (DN)	Max. length or dimension L_1 in (mm)	Max. length or dimension L_2 in (mm)
2 (50)	4 (102)	6 (152)
3 (80)	6 (152)	6 (152)
4 (100)	9 (229)	9 (229)
6 (150)	12 (305)	18 (457)
8 (200)	24 (610)	18 (457)
10 (250)	24 (610)	32 (813)
12 (300)	24 (610)	34 (864)
14 (350)	24 (610)	36 (914)
16 (400)	24 (610)	140 (1016)
18 (450)	36 (914)	48 (1219)
20 (500)	120 (3048)	48 (1219)
24 (600)	240 (6096)	48 (1219)

Welding

All welded pipe joints to be lined with rubber are to be continuous solid welds. All welds to be lined with rubber must be smooth with no porosity, holes, high spots, lumps, pockets, or undercuts. Grinding shall be used to remove sharp edges or high spots.

Nozzles, pad flanges, or reinforcement plates shall be properly braced. Maximum allowable tolerance for overall pipe length, including gaskets, is $\frac{1}{8}$ in (3.2 mm).

Interior corners to be rubber lined are to have a minimum radius of $\frac{1}{8}$ in (3.2 mm). Weld splatter must be entirely removed.

All joints, when possible, shall be welded using backing rings on the inside. If

welding with backing rings is not possible, then all welds must penetrate to the inside diameter of the pipe; thus leaving the inside diameter smooth.

In all cases, the fabricator shall assume responsibility for the strength of welds. All sharp edges and corners shall be ground smooth and have a contoured surface.

Metal Preparation

All metal surfaces to be lined shall be blasted to a white metal finish. White metal blasting is the process of removing all foreign matter (such as rust, scale, and paint) by the use of abrasives propelled by using 100 psi (690 kPa) of air. The surface finish will become a metallic gray-white color, with a roughened anchor pattern providing a 1.5 to 3 mil (37.5 to 75 micron) profile. Other acceptable standards are provided by the Structural Steel Painting Council (SSPC) or National Association Corrosion Engineers (NACE).

Cementing

Primer shall be applied immediately after removal of dust and sandblasting to prevent rusting. Additional coats of primers and cements may need to be applied as specified by the lining manufacturer. Primers and cements are normally applied on the inside of pipe with a swab, spray, or roller. Sufficient drying time between cement coats is required.

LINING GUIDELINES

Sheets of rubber are unrolled and cut to the desired size and shape on a clean, heated table. Care shall be taken so that the tie gum (sticky) side of the lining is facing out for cementing (see Fig. B11.1). The edges can be cut with a skive (30

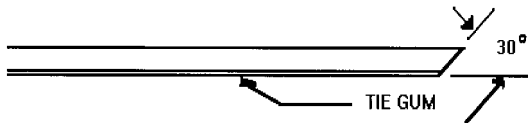

FIGURE B11.1 Cutting stock showing at 30° bevel for a close skive joint.

to 45° angle) to aid in forming the seam. For best results the plastic side of the lining, once removed, is cemented and applied to the substrate. When the lining requires preshrinking, it is unrolled on the table and allowed to shrink prior to being cut to the proper size.

Two styles may be used to make a seam; a *butt skive joint* without cap strips



FIGURE B11.2 Butt seam.

(Fig. B11.2) and overlap (open or closed skive, Fig. B11.3). Referring to the lining specification ensures the proper seam style is applied. The butt skive is shown, along with an overlap method with a closed skive. Open skives are used when the rubber is a *one-construction lining*. One-construction lining is made with one type of rubber. A closed skive procedure is used on a multiple construction lining to protect the underlying plies. *Multiple construction rubber linings* refer to linings

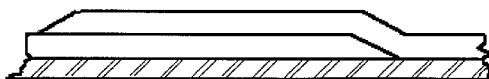

FIGURE B11.3 Closed skive overlap.

that have more than one type of rubber in the layers (Fig. B11.4). For example; a three-ply lining may have a tie gum which is bonded to the substrate; a middle layer of hard rubber to resist permeation of a particular chemical; and a cover lining which resists abrasion or another type of chemical. Multiple construction linings are designed using a tie gum placed on one side of the lining and may have other layers to provide greater chemical and temperature resistance.

Lining Procedure for Standard Flanged Pipe

A tube shall be formed with lining stock using longitudinal skived seams. This is accomplished by wrapping the lining stock around a mandrel, using a liner inside the tube, or any other method to facilitate the making of a tube (Fig. B11.5). The spliced tube's outside circumference is slightly smaller than the inside circumference of the pipe to be lined. When forming the tube, the seam is formed by using steady, firm, and overlapping strokes with a roller. When rolling, always work toward the edges. This forces all the air out from behind the overlapping layers of lining or

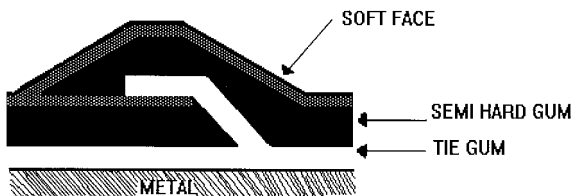

FIGURE B11.4 Multiple construction lining (3-ply shown).

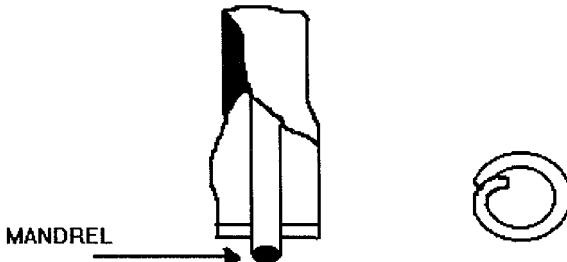

FIGURE B11.5 Method of building tube.

along the butt skive (Fig. B11.6). The spliced tube's length is longer than the pipe's length (Fig. B11.7).

Twisted multifilament strings (called bleeder strings) are then applied lengthwise to permit proper air venting between pipe and lining. String made from synthetic yarns is not to be used. Stringing is done after cementing the pipe, and the individual strings are spaced equally around the circumference. Normally, four strings are

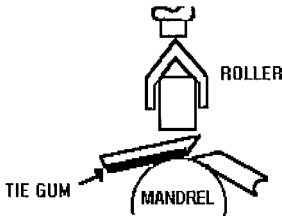

FIGURE B11.6 Rolling operation.

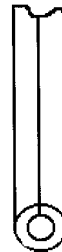

FIGURE B11.7 Finished tube.

used on pipe of sizes up to and including NPS 6 (DN 150). Larger-sized pipe normally requires the use of additional strings. The use of strings is optional with applicators.

The tube is enclosed in a liner and a tow rope is attached to it. The tube is then pulled into the pipe with a slow constant pull (Fig. B11.8). One of two methods is used to seal the liner against the inside surface of the pipe.

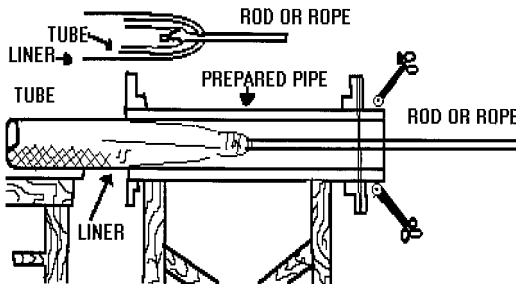

FIGURE B11.8 Pulling in tube.

Method 1. The liner is removed and the tube expanded against the pipe wall by using air pressure. A mechanical extension and flange arrangement is used to seal the pipe ends and a minimum of 100 psi (690 kPa) internal pressure is maintained in the expanded tube for at least 5 minutes. If any air blisters are found after the air pressure is removed, they are punctured, vented, and repaired with a 2 in (50 mm) patch. For a finished cross-sectional view see Fig. B11.9.

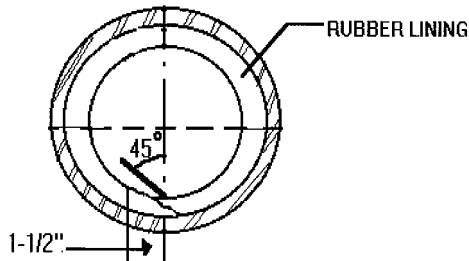

FIGURE B11.9 Longitudinal seam detail.

Method 2. After the liner is removed, an air bag or *balloon* is pulled through the pipe, with stops at intervals where it is alternately inflated and deflated. Next, the extension is removed, the excess stock flared over the flange face, and trimmed flush. A covering is then applied to the full face of the flange. The inside diameter (I.D.) of the flange stock is skived to slightly less than the I.D. of the lining and stitched firmly to the tube stock or folded out and onto the flange surface. When using hard rubber lining on flanges, it is important that the pipe installer/user understand that soft rubber gaskets are required over the face lining.

On pipe sizes larger than NPS 6 (DN 150), the flange stock is lapped onto the lining instead of the skive used on smaller sizes. This lapping technique makes a stronger joint and is the preferred method. Some customers may prefer not to have laps at the flanges because of abrasion considerations or requirements on full line capacity (see Fig. B11.10 and B11.11 for rubber lining of flange facings).

See Fig. B11.12 and B11.13 for suggested lining styles of lateral nozzles and side outlets. Notice how the rubber is lapped into the main-run length of pipe.

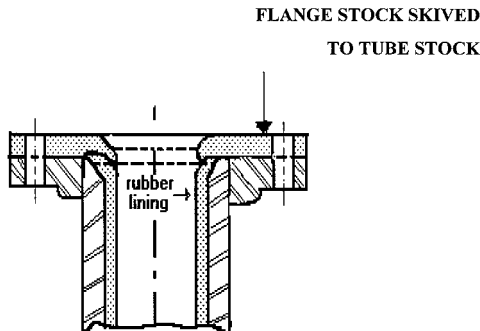

FIGURE B11.10 Flange face rubber lining.

TUBE STOCK SKIVED
TO FLANGE STOCK

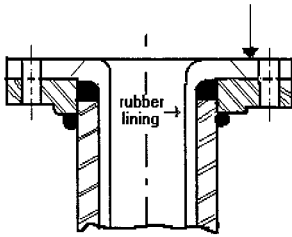

FIGURE B11.11 Flange face rubber lining.

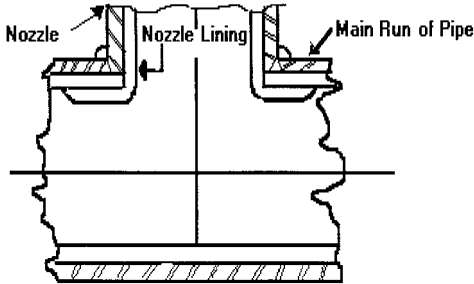

FIGURE B11.12 Rubber lining of nozzle or branch connection.

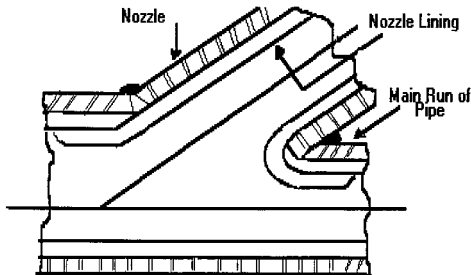

FIGURE B11.13 Rubber lining of lateral nozzle or branch connection.

Lining Procedure for Large-Diameter Pipes

Piping that is too large to safely line by inflating a tube, but large enough to allow personnel to enter, is lined in the same manner as tanks or ductwork. Bleeder strings are used at the applicators option, to facilitate the escape of gases during curing. The stock is flared over the flange face and trimmed or buffed flush after the cure.

Next, a covering is applied to the full face of flange. The I.D. of the flange stock is then skived to slightly less than the I.D. of lining and stitched firmly to the tube stock. On larger-sized pipe, the flange stock is lapped into the pipe lining instead of applying the skive technique used on smaller pipe or applying lining to flange first. The lined pipe is cured as specified by the lining manufacturer. The best cure results will be obtained by using a steam autoclave.

After curing, the ends of the pipe are buffed to remove any excess rubber. This provides a smooth fit during installation at the plant site.

Lining Procedure for Victaulic Pipe

The inside of pipe shall be lined in accordance with procedures used for standard flanged pipe.

When using $\frac{1}{8}$ through $\frac{1}{4}$ in (3.2 through 6.4 mm) linings, the tube lining is extended over the end of the pipe and bent back into the recess on the outside of the pipe. A round of friction tape is then applied over the rubber on the outside diameter (O.D.) of the pipe end. After the pipe is cured, the tape is removed and

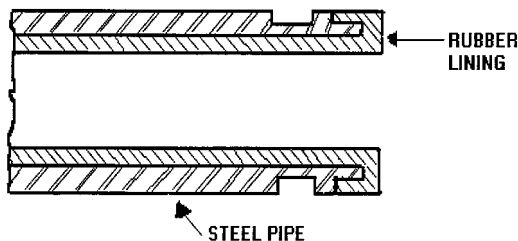

FIGURE B11.14 Rubber lining of grooved pipe.

the O.D. buffed flush with the O.D. of the metal (Fig. B11.14). Other styles of pipe joints have been designed. These styles must be designed to prevent crushing or tearing the rubber during installation and use. Soft (30–40A Duro) rubber lined flanges must never be squeezed more than one-third their thickness. Harder rubber linings can't be squeezed, and will require a soft rubber gasket on the flanges.

TABLE B11.5 Limitations on Weld Seams

Pipe size		Maximum number of weld seams	
NPS	DN	Longitudinal	Circumferential
3–6	80–150	1	1 [in 10 to 14 ft (3 to 4.25 m) length]
8–16	200–400	2 (180° apart)	2 [in 20 ft (6 m) length]

TABLE B11.6 Maximum Straight Lengths

Pipe size		Maximum straight length
NPS	DN	
2–3	50–80	14 ft (4.3 m)
4–8	100–200	24 ft (7.3 m)
8–42	200–1050	40 ft (12.20 m)

Table B11.5 lists the maximum number of longitudinal and circumferential weld seams in a given length of pipe.

Table B11.6 provides the maximum straight length of pipe for a given pipe size which can be lined with rubber. The maximum straight lengths of different size pipes that can be lined depends upon the capabilities of the rubber lining applicator. Straight lengths of pipe up to 60 ft (18.29 m) long have been successfully lined.

PROTECTING RUBBER-LINED PIPE

Many sources for potential problems await rubber lined piping during installation at job sites. A partial, but not all inclusive, list of those sources is as follows:

1. Ozone from welding: Ozone can and will cause severe cracking of natural rubber in linings, and the corrosion barrier may be breached permanently.
2. Portable generators, power relay stations, and electric motors are a potential source of ozone.
3. Fumes from generators, such as nitrous oxide, are detrimental to rubber linings.
4. Arcing from electrical equipment and hook-ups generate a corona (ozone) environment.
5. Oils and liquids of many types cause softening and deterioration of the rubber.
6. Problems may occur from any one or more of the above sources and can occur either inside or outside of the structure being erected. Suitable protection must be provided.

Some suggested means for protection are:

- Installation of rubber lining should be done as near the end of the construction phase as possible.
- Openings to rubber-lined equipment should be closed as much as possible to prevent attack from hazards such as those noted.
- The ends of rubber-lined pipe should be blanked off and kept that way until ready for use. Lining on flanged faces should be protected during shipment or storage by covering with plywood or other suitable material.
- All portable rubber-covered items should be covered up for protection.
- Each piece should be identified by stamping on a ground area in such a manner that numbers will remain visible. Stencil: “Rubber Lined—Do Not Cut or Weld.”

- Additional protective measures are available from rubber lining manufacturer publications.

ASSEMBLY, TESTING, INSPECTIONS, AND MAINTENANCE

Assembly on the Job Site

Care shall be taken to ensure that the rubber lined flange is not damaged by being cut or crushed during assembly. The rubber lining on a flange must not be compressed more than one-third of its thickness, or the lining could tear away from the metal surface, causing a leak. Listed below are recommendations for gasketing and bolt tightening rubber lined pipe, flanges, and equipment:

- The gasket thickness should be equal to or slightly less than the rubber lining, but not less than $\frac{1}{8}$ in (3.2 mm).
- The gasket hardness should be equal to or slightly less than the hardness of the rubber lining, but not greater than 60 (Shore A).
- The surface of the lining in contact with the gasket should be treated with a release coating which will allow disassembly without causing damage to the lining.
- All bolts should be initially tightened until they are snug. Then each bolt should be torqued down to 15 ft · lb (20.3 N · m) using standard cross pattern techniques.
- After 24 hours, bolts should be checked to ensure that 15 ft · lb (20.3 N · m) is maintained. After the line or equipment is put in service, someone should check to ensure that there are no leaks. If a leak is observed, the bolts should be tightened evenly and only enough to stop the leak.
- For high-pressure applications [greater than 300 psi (2070 kPa)], flanges may require a high-pressure design versus the typical flat-face design.
- The alignment of all flanges should have a tolerance of $\frac{1}{32}$ in (0.79 mm).

Testing

The test procedure outlined in this subsection measures the ability of rubber to withstand the effect of liquids. It is designed for testing specimens of elastomeric vulcanizates cut from standard sheets (ASTM D3182). The lining manufacturer can supply these for the lining specified.

In view of the wide variations often present in service conditions, this test may not give direct correlation with service performance unless the actual vessel considered for lining is utilized. However, this test method yields data on which to base judgment as to expected service quality.

This provides a method for exposing test specimens to the influence of liquids under definite conditions of temperature and time. The resulting deterioration is determined by noting the changes of volume, weight, and hardness before and after immersion in the test liquid.

For purpose of the test, it is desirable to use the liquid with which the vulcanizate will come in contact in service. Several small spools can be lined for the purpose of the test with various rubber linings.

If desirable, laboratory testing can be performed as outlined in ASTM D471. The standard specimen shall be square having dimensions of 6 in \times 6 in (150 mm \times 150 mm). Thickness of sample shall be 0.125 in (3.2 mm). The lining manufacturer can supply the proper sheet for the lining specified.

Three sample specimen squares shall be prepared for each composition to be tested. Two shall be immersed and one retained for the original data.

If necessary, this procedure can continue for more immersion cycles or longer periods; 168 to 672 hours are normally sufficient to be predictive.

During immersion, records of temperature and concentration which vary from the normal operating conditions should be maintained.

The following information is recorded with samples and sent to the manufacturer of the lining for evaluation.

1. State that the test was conducted in accordance with this test procedure.
2. Date and temperature of place of test.
3. Dates of various periods of immersion.
4. Immersion liquid utilized.
5. Temperature of exposure.
6. Statement of condition of exposed specimens from visual and manual examination.
7. Results of immersed and nonimmersed specimens in accordance with the ASTM D471 test method.
8. Report hardness before and after immersion in compliance with ASTM D2240.

Obviously, unsuitability of lining would be swelling, deterioration, delamination, softening, or hardening. Some chemicals may exhibit one of the noted characteristics but still provide adequate service life. This is why the lining manufacturer must be consulted throughout the process.

Testing Under Process Conditions

Operating environments in many industries today are more corrosive, chemical compositions are more complex, concentrations are greater, and processing temperatures are higher than in the past. Thus, if a lining is being considered, it is often beneficial for the consumer to evaluate rubber-lined samples under actual process conditions. A proper evaluation following an appropriate period of exposure would include a percent weight change and volume change of the sample, a change in hardness and surface appearance, and the degree and rate of permeation which is extremely important to check. In some cases, a destructive permeation can occur without significant change in the weight, volume, hardness, or appearance of the lining.

Often the vapor phase of a chemical is overlooked when testing for a lining. In some conditions, rubber lining exposed to chemical vapors can be affected more severely than an immersed lining.

Among the tests and test methods that can be used for rubber linings are: chemical resistance (immersion), ASTM D 471; chemical resistance (test cell), ASTM D 3491; abrasion resistance, ASTM D 3389; adhesion, ASTM D 429; tensile-elongation, ASTM D 412; absorption, ASTM D 471; and hardness, ASTM D 2240.

TABLE B11.7 Service Condition Information Required

1. Process or operation:	_____
2. Equipment involved:	_____
3. What chemicals are present and what are their minimum, maximum and operating concentrations? (Also include any impurities or incidental materials present, even though in traces only.)	_____ _____
4. Temperature: minimum _____ maximum _____ operating _____	
5. Are there any abrasive materials present and, if so, what is the:	
a. nature of abrasive material	_____
b. percent of solids	_____
c. degree of abrasion (What is present service life of equipment?)	_____
6. Operating pressure (psi) _____ or vacuum (inches of mercury) _____	
7. Is slight contamination or discoloration of solution objectionable?	_____
8. Is equipment a welded fabrication or casting? (If alloy, advise type.)	_____
9. Has this type of equipment been rubber lined before? If so, advise type of rubber lining and service life obtained.	_____
10. Have there been rubber failures in this service?	_____
If so, were they:	
a. in the liquid or vapor phase?	_____
b. hardening or swelling failures?	_____
c. caused by abrasion?	_____
11. Will the pipe lining be exhaust steam cured?	_____
12. Will there be supplemental heating of the tank contents (inner coils, recirculation, through a heat exchanger or external coils around the pipe walls)?	_____
13. Will the lining be exposed to any thermal shock?	_____
14. What are the consequences if the pipe lining should fail?	_____

Table B11.7 is a form devised to help the specifier gather the information necessary to make an informed decision.

Inspections

The general appearance when looking inside of the pipe shall be observed and noted. Seams and lining should not have any lumps, blisters, or looseness, or have any open seams. The following inspections and tests are performed:

Hardness. The durometer hardness is checked in accordance with ASTM D 412. This checks the cured hardness against that specified by the rubber manufacturer.

This is done 24 hours after completion of cure to allow the rubber to achieve its optimum properties. While the hardness or durometer reading in the laboratory under the proper conditions can produce consistent results; its use in a pipe by different people at different times, pressures, and methods can result in appreciable variations. This is especially true when the instrument requires a flat surface to make an accurate reading. There may be a variance in durometer readings of ± 10 Shore A or D when lining is pressure cured in an autoclave or in an open atmospheric steam; or ± 15 for a chemical-cured lining.

Pinholes. To detect pinholes and otherwise determine a lining's integrity, a high-voltage holiday detector or spark tester is used. A spark tester consists of a wand to which an electrical voltage is applied. The wand is passed over the lining at a rate of approximately one foot per second. Where there is a pinhole or other form of discontinuity in the lining, the current will pass through the discontinuity to the underlying steel and set off an alarm. But the current emanating from the tip can also pass through the lining to the pipe, if excessive voltages are applied. Thus, a spark tester used by anyone other than an experienced inspector can severely damage a lining. Precautions must be taken when using a spark tester. The possibility of damage must be weighted against the benefits of its use as an inspection instrument. This test is usually performed only on large-diameter pipe, NPS 24 (DN 600) or larger, or on small diameter pipe, NPS 6–8 (DN 150–200). Special equipment is usually required to ensure that the spark tester can reach all areas inside the long lengths of the pipe. It is quite imperative that the spark voltage settings are proportioned to the thickness of the lining to be tested. The following range of voltages are recommended:

Lining Thickness

$\frac{1}{8}$ in (3.2 mm)

$\frac{3}{16}$ in (4.85 mm)

$\frac{1}{4}$ in (6.4 mm)

Minimum Voltage

6250–8500 volts minimum

10,000–12,500 volts minimum

12,500–15,000 volts minimum

Materials such as neoprene- and graphite-loaded linings require even lower voltage ranges; 7500 volts for $\frac{1}{8}$ in (3.2 mm) and $\frac{3}{16}$ in (4.85 mm); and 10,000 volts maximum for a $\frac{1}{4}$ in (6.4 mm) thickness. Spark testing should be performed only when it is considered necessary. Frequent spark testing may lead to extensive repair work. Used linings generally have reduced electrical resistance, especially after several years of service. Where salts have saturated the surface, or the solution has penetrated the lining, spark testing becomes more sensitive. Cracked linings also have a loss of gauge in the cracked area. In these cases, spark testing must be done with extreme caution, with a very low voltage setting.

The spark-testing equipment must be kept constantly moving; otherwise it could burn through the lining and create pinhole leaks. A leak would be seen as a white or blue arc jumping from the spark tester wand through the lining to the metal. If a leak is detected, this area should be marked and repaired prior to curing.

Maintenance

Rubber-lined pipe can be a large investment for a company. Thus, proper care and maintenance are always recommended. An experienced applicator can offer many detailed suggestions. Some basic considerations of maintenance are: avoid impact, such as can occur from dropped tools; prevent exposure to sunlight and outdoor

weathering; and protect from sudden temperature changes, which may cause thermal stresses that result in cracking, especially in hard rubber linings.

LINING SELECTION CONSIDERATIONS

Thickness Selection

Lining thickness may vary from $\frac{1}{8}$ to $\frac{1}{4}$ in (3 to 6 mm). In some very abrasive conditions, up to 1 in (25 mm) has been applied. Experience has proved that not only the rate of abrasion must be considered but temperature also. For temperatures greater than 140°F (60°C), $\frac{1}{4}$ in (6 mm) thick lining will provide better service. Table B11.8 shows the recommended maximum lining thicknesses for different pipe sizes.

The most commonly used and economical lining thickness is $\frac{1}{4}$ in (6 mm). It offers long life for a wide range of applications.

Material Selection

The most important factor in selecting the right lining material is specific *chemical resistance* that will be required. The manufacturer must be consulted early in the specification process to ensure the right lining for the application. This subsection describes the most common elastomers used in pipe lining.

TABLE B11.8 Recommended Maximum Lining Thicknesses

Pipe Size NPS (DN)	Lining thickness, inch (mm)				
	$\frac{1}{4}$ (6.4)	$\frac{3}{8}$ (9.53)	$\frac{1}{2}$ (12.7)	$\frac{3}{4}$ (19.1)	1 (25.4)
2 (50)	X				
3 (80)	X				
4 (100)	X				
6 (150)	X	X			
8 (200)	X	X	X		
10 (250)	X	X	X		
12 (300)	X	X	X	X	
14 (350)	X	X	X	X	
16 (400)	X	X	X	X	
18 (450)	X	X	X	X	
24 and larger (600 and larger)	X	X	X	X	X

The second most obvious consideration in rubber lining is *abrasion resistance*. Generally, the softer the rubber the more resistant it is to *impact abrasion*. The harder the rubber the more resistant it is to *sliding abrasion*. Natural rubber and some other linings can be compounded over a range of hardness. Often a compromise must be reached between abrasion resistance and chemical or solution permeation (attack). For example, a soft rubber would be more impact abrasion resistant, but a hard rubber may be needed for permeation or chemical resistance. The rubber manufacturer should be consulted in these situations.

Temperature resistance, another important factor, can also depend on the hardness of the rubber lining compound. Hard natural rubber is more temperature-resistant than soft natural rubber; but the temperature resistance of synthetic rubber is determined more by the type of polymer used, such as neoprene and butyl.

Soft elastomeric linings are often considered suitable for temperatures up to 150°F (66°C) and semi-hard or hard linings up to 180°F (82°C). Certain synthetic elastomers can be successfully used to temperatures of 220°F (104°C). The destructive effects of chemicals on linings at elevated temperatures is accelerated. Oxidation and diffusion are more rapid, so the overall life of the lining may be shorter. To enhance the life of linings at elevated temperatures, a thickness of ¼ in (6.4 mm) or more is commonly recommended.

Elastomeric sheet linings resist many chemicals and are considered suitable for the following, subject to both temperature and concentration factors:

- Most inorganic acids, such as hydrochloric, phosphoric, sulfuric, hydrofluoric, and hydrofluosilicic
- Many organic acids, including acetic, tannic, and gallic
- Inorganic salt solutions, including ferric chloride, zinc chloride, tin chloride, sodium cyanide, and ferrous sulfate
- Inorganic bases, such as sodium hydroxide, calcium hydroxide, and potassium hydroxide
- Plating solutions, including nickel, brass, tin, zinc, silver, and cadmium
- Bleach solutions, such as sodium hypochlorite, calcium hypochlorite, and chlorine

Table B11.9 lists some common chemicals and the general polymer used for a lining. The manufacturer of the lining shall be contacted for advice about the proper lining selection. In-service testing may be needed to confirm the suitability of the material selected.

Common Elastomers

A brief description of each of the most common elastomers, with its general chemical resistant properties, is provided in this subsection.

Natural rubber has been used as a protective covering almost since its discovery. It can be produced in many ways, to create soft elastic and resilient compounds, or as hard as an ebonite-type product. The high sulfur, semihard, or hard versions offer vastly different properties. The inherent saturation affected by the high sulfur level creates a lining which exhibits greater resistance to chemical attack and permeation; but is most prone to commodity contamination through leaching of sulfur compounds into the contents of a vessel. Thermal and mechanical shock offer substantial hazards when the hard stock is used; but by compounding, an acceptable

TABLE B11.9 Chemical Resistance of Various Linings

Corrosion Media	°F (°C) Max temp of	Percent Concentration (%)	Nat. Rubber		Butyl	EPDM	Neop.	Nitrile	Hypalon	Urethanes
			soft	hard						
Abrasion	-	-	R				R			R
Acetic acid	140 (60)	100		R	R					
Ammonium sulfate	200 (93)	saturated		R	R		R			
Chlorine gas wet	175 (79)	saturated		R						
Copper cyanide	160 (71)	saturated	R	R						
Ferric chloride	175 (79)	saturated	R	R						
Hydrochloric	125 (52)	37	R							
Hydrofluoric	90 (32)	50			R					
Kerosene	90 (32)	saturated						R		
Nickle chloride	190 (88)	saturated		R	R					
Nitric acid	150 (66)	10			R				R	
Phosphoric acid	140 (60)	85			R					
Sodium chlorite	190 (88)	saturated	R							
Sodium hypochlorite	150 (66)	15			R					
Sodium hydroxide	194 (90)	50			R		R			
Sodium sulfate	190 (88)	saturated	R	R	R					
Sulfuric acid	180 (82)	20			R					
Sulfuric acid	150 (66)	50							R	
Water—fresh	175 (79)			R		R				
Water—salt	175 (79)						R			
Water—mine tailings	120 (49)			R			R			R

R = Recommended for the corrosion medium shown. Additional service conditions, such as exposure to sunlight, must also be considered before a lining is selected.

level of flexibility can be achieved to tolerate these conditions. The harder the rubber lining the better it can withstand higher temperatures.

Natural rubber linings have been known to handle many acids, alkalis, and other corrosive materials; however, strong oxidizing agents such as chromic and nitric acids attack natural rubber with vigor. Another limitation of natural rubber is its inability to withstand hydrocarbons such as benzene, toluene, gasoline, etc.

Natural rubber hardness ranges from 30 to 100 durometer (Shore A) and can withstand temperatures up to 190°F (88°C).

Butyl has gained prominence since its birth for inner tubes, diaphragms, and similar products, because of its excellent low permeability to gases. Butyl has also found wide application in the electrical insulation field because of its inherently good electrical properties and exceptional resistance to deterioration by heat, ozone, and weathering. Another quality in its favor is its extremely low water absorption characteristic. Because butyl has a high degree of chemical saturation, it can be compounded to offer greater resistance to heat and many chemicals, especially the oxidizing acids. But like natural rubber, butyl offers little resistance to petroleum oil and solvents. Butyl linings generally range in the 50 to 70 (Shore A) hardness, and some can be used in high-temperature applications up to 260°F (127°C).

EPDM has excellent weather- and ozone-resistance that is vastly superior to any other comparably priced polymer. It possesses good heat resistance over a wide range with a temperature resistance of 200°F (93°C). Hardness for EPDM linings can range from 50 to 70 durometer (Shore A). EPDM offers good resistance to water, acetic acid, and weak solutions of chromic acid. However, it has been established that even at higher levels of hardness hydrochloric acid will penetrate EPDM and have a destructive effect on the steel without showing any adverse effect on the rubber. This shows that the permeation not only of water but of chemicals is critical in the selection of the lining.

Nitrile rubber linings have gained increasing acceptance based on their exceptional resistance to petroleum products such as solvents, oils, and greases. The temperature resistance is good up to 200°F (93°C). The hardness is moderate to hard, 50 to 90 durometer (Shore A).

Urethane is a unique polymer in that it can be sprayed on. Urethanes can be applied up to several inches thick and offer great sliding abrasion and hydrocarbon resistance, but they lack resistance to many chemicals. Urethanes range in hardness from 50 to 90 durometer (Shore A). The service temperature for urethane is 120°F (49°C).

Neoprene is available in many types and with a variety of uses, which has made it a household name. Neoprene can be compounded to withstand temperatures up to 200°F (93°C) and effectively resist chemical attack by moderate chemicals, such as sodium hydroxide and seawater. It is also known to be moderately oil resistant. Durometer hardness ranges typically between 50 and 70 (Shore A). Neoprene is attacked by strong oxidizing acids and ketones.

Hypalon is a highly versatile polymer, capable of being compounded for excellent resistance to heat, flame, ozone, weather, tear, and abrasion. It offers resistance to oil and grease. Hypalon, because of its resistance to the effects of chemical oxidation, has gained recognition in the handling of chromic acid (10%) and hydrogen peroxide (30%). Operating temperature can be as high as 200°F (93°C). Hardness can be from 50 to 60 durometer (Shore A).

The foregoing guidelines will be useful in selecting the best lining for the service; however, specification writing should only be done after consulting with the lining manufacturer and possibly even testing of various linings in the media.

SUMMARY

Elastomeric linings can effectively protect piping and other components from harshly corrosive and abrasive environments. Rubber lining technology continues to advance with the development of new polymers, application techniques, and equipment.

GLOSSARY

This glossary describes and explains terms related to the manufacture, preparation, application, and testing of rubber and elastomeric lining materials used in the protective linings industry. Many of the terms are used in the specification and application of corrosive and abrasive resistant materials. This glossary includes chemical names, abbreviations, identifications, and colloquial expressions.

Abrasion Resistance. The resistance of a material to loss of surface particles due to frictional forces.

Acid Resistant. The ability to resist the action of identified acids within specified limits of concentration and temperature.

Adhesion. The state in which two surfaces are held together by interfacial forces which may consist of molecular forces or interlocking action, or both. Adhesion values for tank lining are often determined by the procedures described in ASTM D429-Test Methods for Rubber Property-Adhesion to Rigid Substrates.

Adhesion Failure. The separation of two materials at the surface interface rather than within one of the materials itself.

Adhesive. A substance capable of holding materials together by surface attachment.

Age Resistance. The resistance to deterioration by oxygen, heat, light, ozone, alone or in combination, during storage or use.

Antioxidant. Same as age resistor, a chemical compounding material used to retard deterioration caused by oxygen.

ASTM. The abbreviation for the American Society for Testing and Materials.

Autoclave. A pressure vessel used for the curing or vulcanization of rubber parts by means of steam under pressure.

Blasting. Surface cleaning and preparation of substrate using abrasives such as airborne sand, grit, or shot.

Blemish. A superficial mark or impression on the surface of green or cured rubber lining.

Blister. A cavity or a sac deforming the surface of a material usually due to expansion of an entrapped liquid or gas. Permeation failures of tank linings in service are sometimes evidenced by blister formation.

Bond. The union of materials by use of adhesives, usually used in relation to parts vulcanized after attaching or being assembled together.

Bromobutyl. Used in a general sense to mean a bromobutyl tank lining construction. ASTM designation BIIR.

Butt Seam. A seam made by placing the two pieces to be joined edge-to-edge.

Butt Splice. A joint made in a rubber part before or after vulcanization by placing the two pieces to be joined edge-to-edge.

Butyl Rubber. A copolymer of isobutylene and isoprene rubber; ASTM designation IIR; chlorobutyl or bromobutyl rubber is the common name for such materials used in lining.

Calender. A machine equipped with two or more heavy, internally heated or cooled rolls, used for the continuous sheeting or plying up of rubber compounds.

Calender Blister. Trapped air between calender plies of a multi-ply rubber buildup.

Cement. A dispersion or solution of an elastomer or compound in a solvent for use as an adhesive or coating.

Chlorobutyl. Used in a general sense to mean a chlorobutyl tank lining construction. ASTM designation CIIR.

Chlorosulfonated Polyethylene. Generic name of an elastomeric material sold as Hypalon,*™ ASTM designation CSM.

Closed Skive. A reverse angle cut along the edge of a rubber panel. This enables the installer to stitch down the cut edge so that the tie gum is protected from exposure to the commodity contained in a tank.

Cure. Similar to cross-linking, while cure covers all types (sulfur, peroxide, radiation, etc.).

Delamination. Separation or splitting, either between plies in laminated goods or occasionally within the homogeneous part itself.

Durometer. An instrument for measuring the hardness of rubber and plastics. The “A” durometer scale is used for flexible materials and the “D” for rigids.

Durometer Hardness. A value that indicates the indentation or resistance to indentation of the indenter point of a durometer. High values indicate harder materials. See ASTM D2280-Test Method for Rubber Property-Durometer Hardness.

EPDM. ASTM abbreviation for a terpolymer of ethylene, propylene, and a diene with the residual unsaturated portion of the diene in the side chain.

Ebonite. A term for hard rubber, made by vulcanization of rubber with high levels (greater than 30 parts) of sulfur, where the high hardness is due to the sulfur content.

Elastomer. A polymeric material which, at room temperature, is capable of recovering substantially in shape and size after removal of a deforming force.

Elongation. Extension produced by tensile stress, usually expressed as a percent of original unit length.

Face. The commodity-contacting surface in tank lining construction.

Face Stock. The commodity-contacting stock in a multi-component lining.

Fish Eye. A thin elongated void in a calendered sheet. This slight cosmetic blemish does not affect the service life of the rubber lining.

Gasket. A deformable material clamped between essentially stationary faces to prevent the escape of matter through an opening or joint.

Gauge (Gage). Refers to a dimension, generally the thickness of a product, as measured by a gauge of some type.

Hardness. The measured resistance to indentation of a material.

Heat Resistance. The property or ability of rubber articles to resist the deteriorating effects of elevated temperatures.

Holiday. A small uncovered or noncoated area in a substrate; usually refers to pinholes in thin coatings of rubber sheeting.

I.D. or ID. Abbreviation for inside diameter.

Immersion Testing. Commonly used to determine the resistance of tank lining compounds to various chemicals. See ASTM D 471-Test Method for Rubber Property-Effect of Liquids.

Lap Seam. A seam made by extending the flat edge of one piece of material flat over the edge of a second piece of material.

Light Aging. Deterioration of compounds when exposed to light (direct or indirect, natural or man-made).

NACE. National Association Corrosion Engineers.

Natural Rubber. Rubber formed in a living plant or tree, usually referring to *Hevea brasiliensis*. ASTM designation NR.

NBR. ASTM designation for copolymers of acrylonitrile and butadiene.

Neoprene. Originally the trade name, now the generic name of polymers and copolymers based on chloroprene. ASTM designation CR.

Nerve. The elastic resistance of raw rubber or compounds to permanent deformation during processing. A nery tank lining will be difficult to lay around tight bends or in corners because of spring back.

Nitrile Rubber. Copolymers of acrylonitrile and butadiene. Same as NBR or Buna-N.

O.D. and OD. Abbreviation for outside diameter.

Off Gauge. Not conforming to specified tolerance on thickness.

Open Seam. A seam in which edges do not meet, forming a void.

Optimum Cure. The time and temperature of cure necessary to develop the desired combination of properties. Several laboratory procedures are available to help determine this point.

Overlap Splice. The edge of a panel which overlaps the end of an adjoining panel. The splice can be open or closed.

Over lay. To add another layer of lining over an in-place tank lining construction. Typical over lays are cap strips and dome ends of tank cars.

Oxidation. The reaction of oxygen with a rubber product, usually accompanied by a change in feel, appearance of surface, or a change, usually adverse, in physical properties.

pH. The measure, on a logarithmic scale of 1 to 14, of the relative acidity or alkalinity of an aqueous solution. Neutral pH (pure water) is 7. Hydrochloric acid would be approximately 1 and sodium hydroxide approximately 13.

Plasticity. The tendency of a material to remain deformed after reduction of the deforming stress to or below its yield stress.

Ply Adhesion. The force required to separate two adjoining plies in a specified width of a rubber product.

Ply Separation. A condition which occurs due to a loss of adhesion between plies.

Polymer. A macromolecular material formed by the chemical combination of monomers having either the same or different chemical composition.

Polymer Chain. The chain of elements that form the basis of the structure of a polymer. The elements may be all carbon atoms, carbon and oxygen, silicone, nitrogen, etc.

Pressure Cure. Vulcanization under pressure.

Profile. Surface profile is a measure of the roughness of a surface which results from abrasive blast cleaning. The height of the profile produced on the surface is measured from the bottom of the lowest valley to the top of the highest peak.

PSI. The abbreviation for pound per square inch.

Qualification Inspection or Test. The examination of samples from a typical production run of products to determine adherence to a given specification for approval to become a supplier.

Quality Conformance Inspection or Test. The examination of samples from a production run of products to determine adherence to a given specification for acceptance of that production run.

Rate of Cure. The relative time required to reach a predetermined state of vulcanization under specified conditions.

Recovery. The degree to which a rubber product returns to its normal dimensions after being distorted.

Reversion. The softening of vulcanized rubber when it is heated too long or exposed to elevated temperatures. It is a deterioration in physical properties. (Extreme reversion may result in tackiness.) This most commonly affects natural rubber linings.

Rubber. An elastomer, generally implying natural rubber, but used loosely to mean any elastomer, vulcanized and unvulcanized. By definition, a material that is capable of recovering from large deformations quickly and forcibly.

Sand blast. To clean with sand or steel grit in a high velocity stream of air.

Seam. A line formed by joining material to form a single ply or layer. A splice.

Semihard Rubber. A term used for hard rubber which when fully cured is flexible and can be bent without shattering.

Shelf Aging. The natural deterioration of rubber articles kept in storage or "on the shelf" under normal atmospheric conditions. This slow deterioration is due primarily to oxygen and ozone attack.

Shelf Life. An expression describing the time a material can be stored without losing any of its properties.

Shore Hardness. A term denoting a hardness value derived from an instrument developed by The Shore Instrument & Mfg. Co., Inc.

Skive. A cut made on an angle to the surface to produce a tapered or feathered edge.

Skive Butt Seam. Two skived edges joined edge-to-edge to form a smooth surface.

Spark Tester. A high-voltage test unit used to detect breaks or holes in a lining.

Specific Gravity. The ratio of the mass of a unit volume of a material to that of the same volume of water at a specified temperature. Specific Gravity is:

$$\begin{array}{ccc} \text{grams/cc of material} & \text{or} & \text{pounds/ft}^3 \text{ of material} \\ \text{grams/cc of water (1)} & & \text{pounds/ft}^3 \text{ of water (62.4)} \end{array}$$

Specific Volume. The reciprocal (1/Sp. Grav.) of specific gravity. Also expressed as the ratio between the volume of one pound of water and the volume of one pound of material.

SSPC. Abbreviation for Steel Structures Painting Council.

Static Spark. A high voltage of static electricity.

Steam Cure (Open). A method of vulcanizing rubber parts by exposing them directly to steam.

Stitching. A method of joining two pieces of uncured rubber compound together by means of a stitching roller, and a hand held tool comprised of a wheel with a narrow edge which is often serrated. It is commonly used to make tank lining splices.

Substrate. The surface on which a coating or lining is applied.

Surface Preparation. The preparation of a substrate prior to applying tank lining: welding, grinding, blasting, cleaning.

Swelling. An increase in volume or linear dimension of a specimen immersed in liquid or exposed to a vapor.

Tack. The property of a polymer, compound, or adhesive that causes two layers to stick together on application of mild pressure. Tacky polymers or compounds do not necessarily stick to other surfaces.

Tack Cement. A formulated rubber/cement mixture which can be rolled or brushed on surfaces which will hold the rubber panel in place until cure takes place. Normally considered a part of the adhesive system.

Tensile Strength. The maximum tensile stress applied during stretching of a specimen to rupture processed per unit area of the specimen, i.e., psi and mPa.

Tie Gum. An intermediate layer of rubber employed to promote bonding of two surfaces; usually a soft rubber compound.

Vapor Phase. Vapor above the liquid in a tank car or closed storage tank; often the most severe conditions for rubber tank lining.

Vulcanization. 1) An irreversible process during which a rubber compound, through a change in its chemical structure (cross-linking), becomes less plastic and more elastic. Elastic properties are conserved, improved, or extended over a greater range of temperature. 2) It often refers to the reaction of rubber specifically with sulfur, while "curing" covers other methods of cross-linking. Both terms are often used interchangeably.

Weathering. A surface deterioration of a rubber article during outdoor exposure.

White Metal Blast. To sand or shot blast a steel substrate to a SSPC No. 5 finish, as specified by the Steel Structures Painting Council (NACE #1).