

NEW AGE

Revised Second Edition

Hydrology

Principles • Analysis • Design

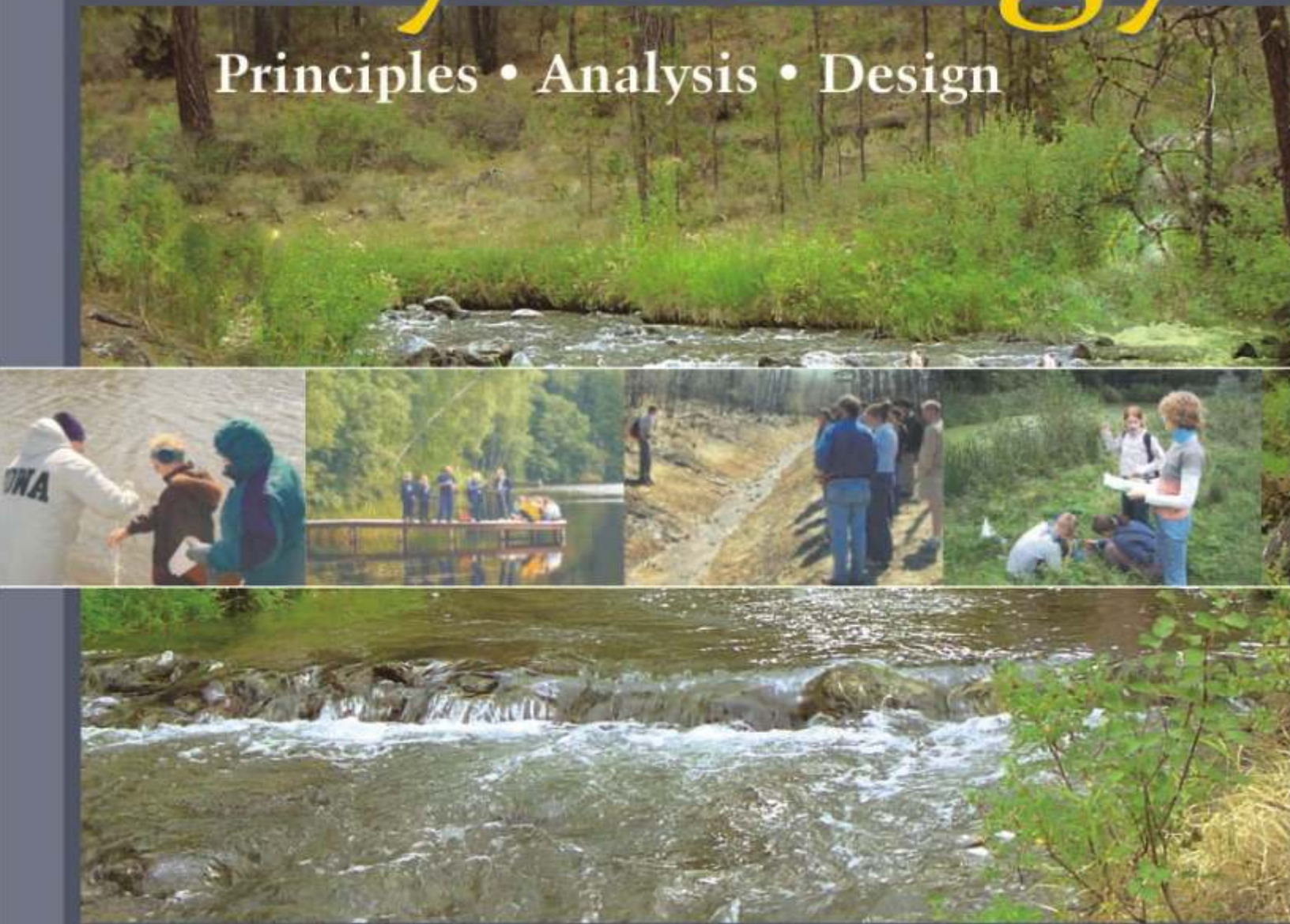

H. M. Raghunath



NEW AGE INTERNATIONAL PUBLISHERS

Hydrology

Principles • Analysis • Design

**THIS PAGE IS
BLANK**

Hydrology

Principles • Analysis • Design

Revised Second Edition

H.M. Raghunath

Formerly, Professor in Civil Engineering,
Manipal Institute of Technology,
Manipal, Karnataka

Now, Advisor in Water Resources Evaluation



PUBLISHING FOR ONE WORLD

NEW AGE INTERNATIONAL (P) LIMITED, PUBLISHERS

New Delhi • Bangalore • Chennai • Cochin • Guwahati • Hyderabad
Jalandhar • Kolkata • Lucknow • Mumbai • Ranchi

Visit us at www.newagepublishers.com

Copyright © 2006 New Age International (P) Ltd., Publishers
Published by New Age International (P) Ltd., Publishers

All rights reserved.

No part of this ebook may be reproduced in any form, by photostat, microfilm, xerography, or any other means, or incorporated into any information retrieval system, electronic or mechanical, without the written permission of the publisher.
All inquiries should be emailed to rights@newagepublishers.com

ISBN (10) : 81-224-2332-9

ISBN (13) : 978-81-224-2332-7

PUBLISHING FOR ONE WORLD

NEW AGE INTERNATIONAL (P) LIMITED, PUBLISHERS

4835/24, Ansari Road, Daryaganj, New Delhi - 110002

Visit us at www.newagepublishers.com

PREFACE TO THE SECOND EDITION

In this new Edition, two more Chapters are included, *i.e.*,

Chapter 17: Instantaneous Unit Hydrograph (IUH) with Clark and Nash Models illustrated with Workedout Examples from field data.

Chapter 18: Cloud Seeding, the technique and operation being profusely illustrated with actual case histories in India and Russia.

Also, some more illustrative Field Examples are included under Infiltration, Storm Correlation, Gumbel's and Regional Flood Frequency.

All, with a good print, sketches being neatly redrawn.

Comments are always welcome and will be incorporated in the succeeding editions.

H.M. Raghunath

**THIS PAGE IS
BLANK**

PREFACE TO THE FIRST EDITION

Hydrology is a long continuing hydrosience and much work done in this field in the past, particularly in India, was of empirical nature related to development of empirical formulae, tables and curves for yield and flood of river basins applicable to the particular region in which they were evolved by investigators like Binnie, Barlow, Beale and Whiting, Strange, Ryves, Dicken, Inglis, Lacey, Kanwar Sain and Karpov, etc.

In this book, there is a departure from empiricism and the emphasis is on the collection of data and analysis of the hydrological factors involved and promote hydrological design on sound principles and understanding of the science, for conservation and utilisation of water resources. Hydrological designs may be made by deterministic, probabilistic and stochastic approaches but what is more important is a 'matured judgement' to understand and avoid what is termed as 'unusual meteorological combination'.

The book is written in a lucid style in the metric system of units and a large number of hydrological design problems are worked out at the end of each article to illustrate the principles of analysis and the design procedure. Problems for assignment are given at the end of each Chapter along with the objective type and intelligence questions. A list of references is included at the end for supplementary reading. The book is profusely illustrated with sketches and is not bulky.

The text has been so brought to give confidence and competence for the reader to sit for a professional examination in the subject or enable him to take up independent field work as a hydrologist of a River basin or sub-basin.

The text is divided into Fundamental and Advanced topics and Appendices to fit the semester-hours (duration) and the level at which the course is taught.

Degree and Post-degree students, research scholars and professionals in the fields of Civil and Agricultural Engineering, Geology and Earth Sciences, find this book useful.

Suggestions for improving the book are always welcome and will be incorporated in the next edition.

H.M. Raghunath

**THIS PAGE IS
BLANK**

CONTENTS

Preface to the Second Edition (v)

Preface to the First Edition (vii)

PART A—FUNDAMENTAL HYDROLOGY

| | | |
|----------|---|-----------|
| 1 | Introduction | 1 |
| 1.1 | World's Water Resources | 3 |
| 1.2 | Water Resources of India | 3 |
| 1.3 | Hydrological Study of Tapti Basin (Central India) | 5 |
| 1.4 | Hydrology and Hydrologic Cycle | 11 |
| 1.5 | Forms of Precipitation | 13 |
| 1.6 | Scope of Hydrology | 14 |
| 1.7 | Hydrological Data | 14 |
| 1.8 | Hydrologic Equation | 15 |
| 2 | Precipitation | 17 |
| 2.1 | Types of Precipitation | 17 |
| 2.2 | Measurement of Precipitation | 18 |
| 2.3 | Radars | 22 |
| 2.4 | Rain-gauge Density | 22 |
| 2.5 | Estimates of Missing Data and Adjustment of Records | 23 |
| 2.6 | Mean Areal Depth of Precipitation (P_{ave}) | 26 |
| 2.7 | Optimum Rain-gauge Network Design | 31 |
| 2.8 | Depth-Area-Duration (DAD) Curves | 33 |
| 2.9 | Graphical Representation of Rainfall | 36 |
| 2.10 | Analysis of Rainfall Data | 38 |
| 2.11 | Mean and Median | 43 |
| 2.12 | Moving Averages Curve | 48 |
| 2.13 | Design Storm and PMP | 49 |
| 2.14 | Snow Pack and Snow Melt | 49 |
| 3 | Water Losses | 60 |
| 3.1 | Water Losses | 60 |
| 3.2 | Evaporation | 60 |

| | | |
|----------|--|------------|
| 3.3 | Evaporation Pans | 62 |
| 3.4 | Soil Evaporation | 66 |
| 3.5 | Unsaturated Flow | 66 |
| 3.6 | Transpiration | 67 |
| 3.7 | Evapotranspiration | 67 |
| 3.8 | Hydrometeorology | 70 |
| 3.9 | Infiltration | 70 |
| 3.10 | Infiltration Indices | 81 |
| 3.11 | Supra Rain Technique | 83 |
| 3.12 | Watershed Leakage | 87 |
| 3.13 | Water Balance | 87 |
| 4 | Runoff | 96 |
| 4.1 | Components of Stream Flow | 96 |
| 4.2 | Catchment Characteristics | 97 |
| 4.3 | Mean and Median Elevation | 101 |
| 4.4 | Classification of Streams | 103 |
| 4.5 | Isochrones | 104 |
| 4.6 | Factors Affecting Runoff | 104 |
| 4.7 | Estimation of Runoff | 106 |
| 5 | Hydrographs | 117 |
| 5.1 | Hydrograph Components | 117 |
| 5.2 | Separation of Streamflow Components | 120 |
| 5.3 | Hydrograph Separation | 122 |
| 5.4 | Unit Hydrograph | 124 |
| 5.5 | Unit Hydrograph from Complex Storms | 130 |
| 5.6 | S-Curve Method | 138 |
| 5.7 | Bernard's Distribution Graph | 142 |
| 5.8 | Instantaneous Unit Hydrograph | 149 |
| 5.9 | Synthetic Unit Hydrographs | 149 |
| 5.10 | Transposing Unit Hydrographs | 154 |
| 5.11 | Application of Unit Hydrograph | 157 |
| 6 | Stream Gauging | 171 |
| 6.1 | Methods of Measuring Stream Flow | 171 |
| 6.2 | Current Meter Gaugings | 174 |
| 6.3 | Stage-Discharge-Rating Curve | 178 |
| 6.4 | Selection of Site for a Stream Gauging Station | 183 |
| 7 | Ground Water | 192 |
| 7.1 | Types of Aquifers and Formations | 192 |
| 7.2 | Confined and Unconfined Aquifers | 193 |
| 7.3 | Darcy's Law | 195 |

| | | |
|-------------------------------|--|------------|
| 7.4 | Transmissibility | 196 |
| 7.5 | Well Hydraulics | 196 |
| 7.6 | Specific Capacity | 199 |
| 7.7 | Cavity Wells | 200 |
| 7.8 | Hydraulics of Open Wells | 202 |
| 7.9 | Construction of Open Wells | 206 |
| 7.10 | Spacing of Wells | 207 |
| 8 | Floods-Estimation and Control | 212 |
| 8.1 | Size of Floods | 212 |
| 8.2 | Estimation of Peak Flood | 213 |
| 8.4 | Flood Frequency Studies | 221 |
| 8.5 | Encounter Probability | 225 |
| 8.6 | Methods of Flood Control | 238 |
| 8.7 | Soil Conservation Measures | 245 |
| 8.8 | Flood Control Economics | 247 |
| 8.9 | Flood Forecasting and Warning | 251 |
| 9 | Flood Routing | 262 |
| 9.1 | Reservoir Routing | 262 |
| 9.2 | Stream Flow Routing | 270 |
| 10 | Storage, Pondage and Flow Duration Curves | 280 |
| 10.1 | Reservoir Mass Curve and Storage | 280 |
| 10.2 | Flow Duration Curves | 285 |
| 10.3 | Pondage | 288 |
| 11 | Reservoir Sedimentation | 298 |
| 11.1 | Sediment Movement and Deposition | 298 |
| 11.2 | Reduction in Reservoir Capacity | 300 |
| 11.3 | Reservoir Sedimentation Control | 303 |
| 12 | Arid, Semi-Arid and Humid Regions | 306 |
| 12.1 | Arid Regions | 306 |
| 12.2 | Semi-Arid Regions | 307 |
| 12.3 | Humid Regions | 309 |
| PART B—ADVANCED TOPICS | | |
| 13 | Linear Regression | 315 |
| 13.1 | Fitting Regression Equation | 315 |
| 13.2 | Standard Error of Estimate | 316 |
| 13.3 | Linear Multiple Regression | 319 |
| 13.4 | Coaxial Graphical Correlation of Rainfall Runoff | 322 |

| | | |
|-----------|--|------------|
| 14 | Statistical and Probability Analysis of Hydrological Data | 327 |
| 14.1 | Elements of Statistics | 327 |
| 14.2 | Probability of Hydrologic Events | 332 |
| 15 | Flood Frequency—Probability and Stochastic Methods | 337 |
| 15.1 | Flood Frequency Methods | 337 |
| 15.2 | Stochastic Method | 344 |
| 15.3 | Stochastic Modelling by the Partial Duration Series | 344 |
| 15.4 | Annual Flood Peaks—River Ganga | 358 |
| 15.5 | Regional Flood-Frequency Analysis (RFFA) | 361 |
| 16 | Mathematical Models in Hydrology | 366 |
| 16.1 | Type of Mathematical Models | 366 |
| 16.2 | Methods of Determining IUH | 371 |
| 16.3 | Synthetic Stream Flow | 379 |
| 16.4 | Flow at Ungauged Sites by Multiple Regression | 381 |
| 16.5 | Reservoir Mass Curve | 381 |
| 16.6 | Residual Mass Curve | 383 |
| 16.7 | Selection of Reservoir Capacity | 383 |
| 16.8 | Flood Forecasting | 386 |
| 16.8 | Mathematical Model | 389 |
| 17 | Instantaneous Unit Hydrograph (IUH) | 393 |
| 17.1 | IUH for a Basin | 393 |
| 17.2 | Derivation of IUH | 393 |
| 17.3 | Other Methods of Derivation of IUH | 394 |
| 17.4 | NASH Conceptual Model | 394 |
| 17.5 | Clark's Model | 397 |
| 17.6 | Drawing Isochrones and Time-Area Diagram (TAD) | 398 |
| 17.7 | Clark's Method | 398 |
| 18 | Cloud Seeding | 403 |
| 18.1 | Conditions for Cloud Seeding | 403 |
| 18.2 | Cloud Seeding Technique | 404 |
| 18.3 | Cloud Seeding Operation | 406 |
| 18.4 | Recent Case History | 406 |
| | Appendices | 407 |
| | Selected References | 453 |
| | Bibliography | 456 |
| | Index | 457 |

PART A

FUNDAMENTAL HYDROLOGY

**THIS PAGE IS
BLANK**

Chapter 1

INTRODUCTION

Hydrology is a branch of Earth Science. The importance of hydrology in the assessment, development, utilisation and management of the water resources, of any region is being increasingly realised at all levels. It was in view of this that the United Nations proclaimed the period of 1965-1974 as the International Hydrological Decade during which, intensive efforts in hydrologic education research, development of analytical techniques and collection of hydrological information on a global basis, were promoted in Universities, Research Institutions, and Government Organisations.

1.1 WORLD'S WATER RESOURCES

The World's total water resources are estimated at 1.36×10^8 M ha-m. Of these global water resources, about 97.2% is salt water mainly in oceans, and only 2.8% is available as fresh water at any time on the planet earth. Out of this 2.8% of fresh water, about 2.2% is available as surface water and 0.6% as ground water. Even out of this 2.2% of surface water, 2.15% is fresh water in glaciers and icecaps and only of the order of 0.01% is available in lakes and streams, the remaining 0.04% being in other forms. Out of 0.6% of stored ground water, only about 0.25% can be economically extracted with the present drilling technology (the remaining being at greater depths). It can be said that the ground water potential of the Ganga Basin is roughly about forty times the flow of water in the river Ganga.

1.2 WATER RESOURCES OF INDIA

The important rivers of India are shown in Fig. 1.1 and their approximate water potentials are given below:

| <i>Sl. no.</i> | <i>River basin</i> | <i>Water potential (M ha-m)</i> |
|----------------|--|-------------------------------------|
| 1. | West flowing rivers like Narmada and Tapi | 30.55 |
| 2. | East flowing rivers like Mahanadi, Godavari, Krishna, Cauvery and Pennar | 35.56 |
| 3. | The Ganges and its tributaries | 55.01 |
| 4. | Indus and its tributaries | 7.95 |
| 5. | The River Brahmaputra | 59.07 |
| Total | | 188.14 |



Fig. 1.1 River basins of India

The rivers of north India are perennial (*i.e.*, the water in sufficient quantity flows in them throughout the year) since they receive the snow melt runoff in summer. Rivers of peninsular India (south India) receive only runoff due to rainfall and have a good flow only during monsoons; many of them are either dry or have negligible flow during most of the remaining part of the year.

The average annual rainfall (a.a.r.) of India is around 114 cm. The isohyetal map of India (*i.e.*, isohyets or lines joining all places having the same a.a.r.) is shown in Fig. 2.8. Based on this a.a.r., Dr. K.L. Rao has estimated the following data.

| <i>Sl. no.</i> | <i>Item</i> | <i>Approximate volume (M ha-m)</i> |
|----------------|---|--|
| 1. | Annual rainfall over the entire country | 370 |
| 2. | Evaporation loss @ $\frac{1}{3}$ of item (1) above | 123 |
| 3. | Runoff (from rainfall) in rivers | 167 |
| 4. | Seepage into subsoil by balance (1)—{(2) + (3)} | 80 |
| 5. | Water absorbed in top soil layers, <i>i.e.</i> , contribution to soil moisture | 43 |
| 6. | Recharge into ground water (from rainfall) (4)—(5) | 37 |
| 7. | Annual ground water recharge from rainfall and seepage from canals and irrigation systems (approximate) | 45 |
| 8. | Ground water that can be economically extracted from the present drilling technology @ 60% of item (7) | 27 |
| 9. | Present utilisation of ground water @ 50% of item (8) | 13.5 |
| 10. | Available ground water for further exploitation and utilisation | 13.5 |

The geographical area of the country (India) is 3.28 Mkm² and the annual runoff (from rainfall) is 167 M ha-m (or 167×10^4 Mm³), which is approximately two-and-half-times of the Mississippi-Missouri river Basin, which is almost equal in area to the whole of India. Due to limitations of terrain, non-availability of suitable storage sites, short period of occurrence of rains, etc. the surface water resources that can be utilised has been estimated as only 67 M ha-m. The total arable land in India is estimated to be 1.47 Mkm² which is 45% of the total geographical area against 10% for USSR and 25% for USA. India has a great potential for agriculture and water resources utilisation. A case history of the 'Flood Hydrology of Tapti Basin' is given below for illustration.

1.3 HYDROLOGICAL STUDY OF TAPTI BASIN (CENTRAL INDIA)

Tapti is one of the two large rivers in central India which flows west-ward (the other one being river Narmada) and discharge into the Arabian Sea. Tapti takes its origin in Multai Hills in the Gavilgadh hill ranges of Satpura mountain in Madhya Pradesh, Fig. 1.2. Tapti is the most significant flood-menacing river as far as the state of Gujarat is concerned.

The River Tapti is 720 km long and runs generally to west through Madhya Pradesh (208 km), Maharashtra (323 km) and Gujarat (189 km) states joining the Arabian Sea in the Gulf of Cambay approximately 20 km west of the city of Surat. The river course according to the topographical features of its run can be divided into four sections as follows:

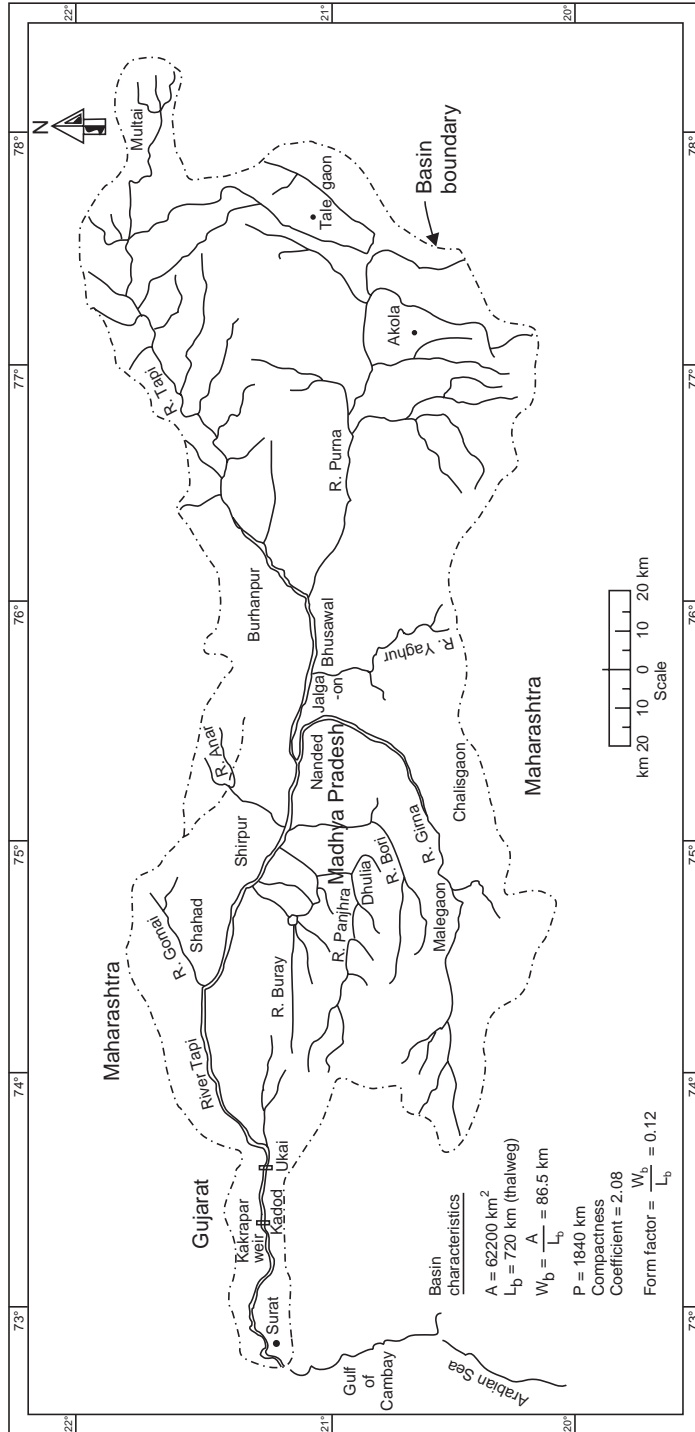

Fig. 1.2 Tapi basin

| | | | | |
|--|---|---|--|--|
| 1. Section | I | II | III | IV |
| 2. Length (km) | 240 | 288 | 80 | 112 |
| 3. Terrain | Dense forests; hill ranges hug the river banks, Rocky bed and steep banks as the river passes through Satpura mountain ranges | Several large tributaries join on both sides. Rich fertile plains of east and west Khandesh districts of Maharastra | Hilly tract covered with forests, Number of rapids between Kamalapur and Kakrapur a distance of 32 km. At Kakrapur the river falls by 7.5 m; beyond Kakrapur the river widens to about 900 m | Low flat alluvial plains of Gujarat. River meanders past towns of Kathor and Surat. Numerous rapids near towns of Mandvi and Kadod |
| 4. Catchment area (km ²) | 1000 (above Burhanpur) | 15000 | | |
| 5. Average bed slope in the reach (m/km) | 2.16 | 0.52 | 0.56 | 0.35 |
| 6. a.a.r. (cm) | 75-150 | 50-75 (heavy rainfall in Ghat catchment of Girna river \approx 150 cm) | 150 | 100-150 |

The catchment areas of the river Tapti above Burhanpur and Bhusaval are 81800 and 31350 km², respectively. The catchment area of the river before it enters the Gujarat state is about 57000 km², while the catchment at Surat is 61800 km². Thus, most of the catchment can be called hilly with good gradients. The important tributaries, their catchment areas and the length of their run are given below:

| <i>Tributary</i> | <i>Catchment area (km²)</i> | <i>River at confluence (km)</i> |
|------------------|--|---------------------------------|
| Purna | 17920 | 282 |
| Waghur | 2352 | 312 |
| Girna | 9720 | 340 |
| Bori | 2344 | 386 |
| Anar | 1350 | 382 |
| Panjhra | 2860 | 400 |
| Buray | 1038 | 424 |
| Gomai | 1263 | 481 |

The river Purna has the biggest catchment. The river Girna has its upper catchment in the eastern slopes of Sahyadri mountains and joins Tapti at its 300th km, only 400 km upstream of Surat city. Due to heavy rainfall of ≈ 150 cm in Ghats, this tributary influences the floods in the Tapti to a great extent.

The River Tapti drains a vast catchment of 62200 km², of which 27600 km² are situated in Madhya Pradesh, 32100 km² in Maharashtra, and 2500 km² in Gujarat. The average annual rainfall over the catchment is 78.8 cm, the maximum being 203 cm. More than 95% of the annual rainfall occurs during the south-west monsoon from mid-June to mid-October. The isohyetal map of normal rainfall during monsoon period is shown in Fig. 1.3. The average annual runoff and 75% dependable yield at Ukai is assessed to be 1.73 and 1.26 M ha-m, respectively.

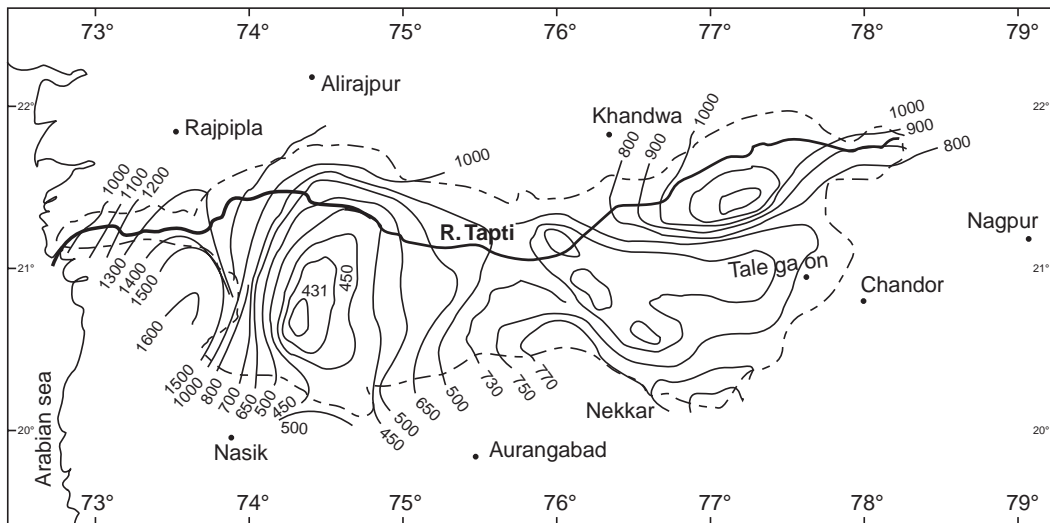

Fig. 1.3 Normal monsoon isohyets of Tapti basin

The map of the Tapti basin and its sub-basins are shown in Fig. 1.2. The shape of the catchment is elongated and becomes narrow as it enters Gujarat. Some catchment characteristics are given below:

- (i) Area of the basin $A = 62200$ km²
- (ii) Perimeter of the basin $P = 1840$ km
- (iii) Length of the thalweg of the mainstream $L_b = 720$ km
- (iv) Average width of the basin $W_b = \frac{A}{L_b} = \frac{62200}{720} = 86.5$ km
- (v) To find the compactness coefficient of the basin:

Radius (R) of the equivalent area is given by

$$\pi R^2 = 62200 \text{ km}^2$$

$$R = \sqrt{\frac{62200}{\pi}} = 142 \text{ km}$$

Circumference of the equivalent circular area

$$= 2\pi R = 2\pi \times 142 = 886 \text{ km}$$

Compactness coefficient of the basin

$$= \frac{P}{2\pi R} = \frac{1840}{886} = 2.08$$

$$(vi) \text{ From factor } F_f = \frac{W_b}{L_b} = \frac{A}{L_b^2} = \frac{62200}{720^2} = 0.12$$

Sometimes, the reciprocal of this taken as the coefficient of shape of the basin (= 8.3).

$$(vii) \text{ Elongation ratio } E_r = \frac{2R}{L_b} = \frac{2 \times 142}{720} = 0.4$$

Narmada and Tapti catchments, which are adjacent are often hit by storms caused by depression originating both from the Arabian Sea and the Bay of Bengal, which cause heavy rains resulting in high floods. The tracks of the monsoon depressions that caused heavy rains* (25.96 cm) during August 4-6, 1968 are shown in Fig. 1.4. The Tapti catchment being not directly affected by the tracks of these storms but falling in the south-western sector of storms,

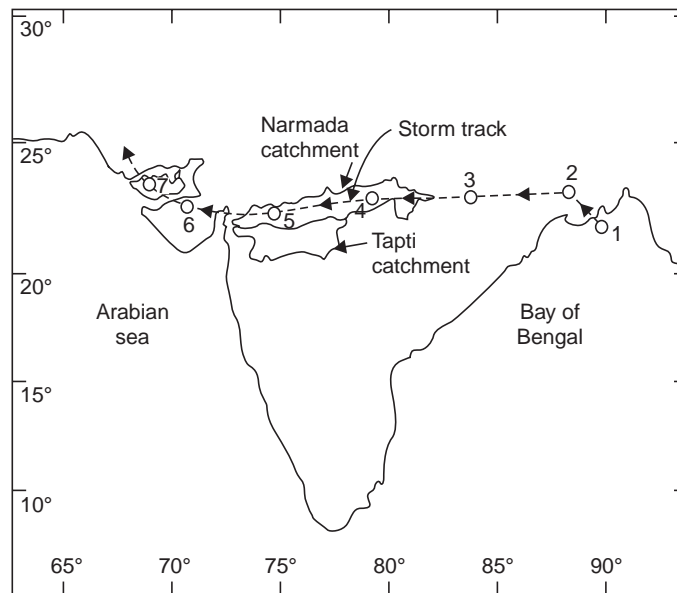

Fig. 1.4 Storm track of August 1968

gets a well-distributed rainfall over its entire catchment except its extreme western end, where a steep isohyetal gradient exists due to the influence of the western Ghats. Many times the depressions move along the river courses synchronising with the movement of floods. This phenomenon causes devastating floods. The river widens out at the lower reach. Low tides come as far as Surat and high tides travel very much upstream. Many times high tides and tidal waves due to storms, synchronise with floods resulting in devastation. Particularly near the Gulf, the water becomes a vast sheet of water extending from Narmada to Mindhola, a

*The highest flood peak of R. Tapti in 1968 was 42,500 cumec, while of R. Narmada was 58,000 cumec in 1968 and 69,400 cumec in 1970.

distance of about 72 km. Therefore a proper flood warning system and raised platforms would be necessary. The city of Surat lies between elevations +21 and +32 m. The river spills over its banks at two places above Surat, *i.e.*, at Dholanparadi above the National Highway and Nanavaracha. These spills are obstructed by high embankments of railways, roads and canals causing interruptions in these services and damages to lands and property due to inundation of floods. The city of Surat and the surrounding fertile delta are quite low and are vulnerable to floods.

The highest ever flood seems to have occurred in 1837; most of the heavy floods have occurred in August and September. The recent high floods in 1959 and 1968 were catastrophic and brought untold damages to industry, commerce and normal life of the city of Surat. An assessment of the damages caused by these floods are given below.

| <i>Sl. no.</i> | <i>Flood in the year</i> | <i>No. of villages affected</i> | <i>Human casualty</i> | <i>Cattle loss</i> | <i>Damage to standing crops (ha.)</i> | <i>Houses damaged or destroyed</i> |
|----------------|--------------------------|---------------------------------|-----------------------|--------------------|---------------------------------------|------------------------------------|
| 1. | 1959 | 194 | 79 | 554 | 30460 | 14815 |
| 2. | 1968 | 505 | 112 | 7649 | 38540 | 30606 |

The 'depth-duration' and the 'depth-area-duration' curves for the heavy storms during August 4-6, 1968 (3 days) are shown in Fig. 1.5 and Fig. 2.15. The weighted maximum rainfall depth for the Tapi basin up to Ukai for 1, 2, and 3 days are 11.43, 22.38, and 25.96 cm, respectively.

The maximum representative dew point of Tapi basin during the storm period (Aug 4-6, 1968), after reducing to the reference level of 1000 mb, was 29.8 °C and the persisting representative dew point for the storm was 26.7 °C. The moisture adjustment factor (MAF), which is the ratio of maximum precipitable water at the storm location to the precipitable water available during the storm period, was derived with respect to the standard level of 500 mb (by reference to the diagram given by Robert D. Fletcher of US Weather Bureau as

$$\begin{aligned} \text{MAF} &= \frac{\text{Depth of maximum precipitable water (1000 mb to 500 mb)}}{\text{Depth of storm precipitable water (1000 mb to 500 mb)}} \\ &= \frac{98 \text{ mm}}{80 \text{ mm}} = 1.23 \end{aligned}$$

The storm of August 4-6, 1968 was 'increased by 23% to arrive at the maximum probable storm (MPS) of 31.8 cm, assuming the same mechanical efficiency. This MPS with minimum infiltration losses and the rainfall excesses (net rainfall or runoff) rearranged during successive 6-hour intervals, was applied to the ordinates of the 6-hour design unit hydrograph (derived from the 1968 flood hydrograph at Kakrapar weir at Ukai) to obtain the design flood hydrograph, the peak of which gave the maximum probable flood (MPF) of 59800 cumec (see example 8.4). The highest flood peak observed during 1876-1968 (93 years) was 42500 cumec in August 1968 (Fig. 1.6). The standard project flood (SPF) recommended by the Central Water and Power Commission (CWPC), New Delhi for the design of Ukai dam was around 48200 cumec and the design flood adopted was 49500 cumec. The MPF recommended by CWPC was also 59800 cumec.

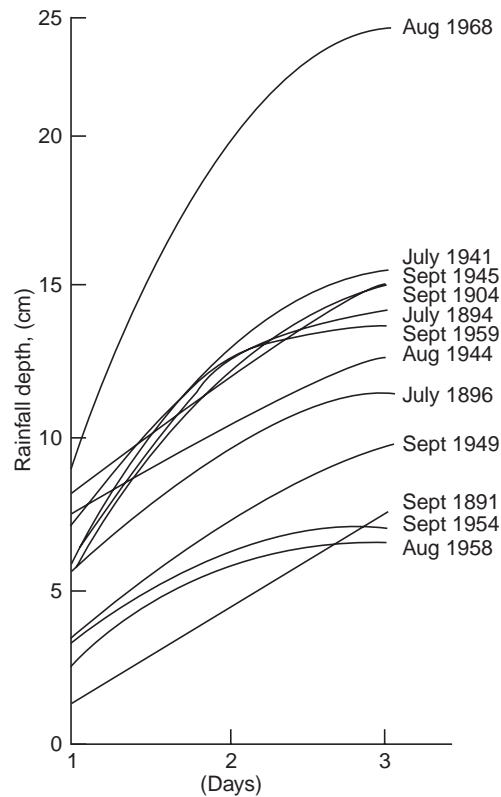

Fig. 1.5 Depth-duration curves for heavy-rain storms of Tapti basin

For the 3-day storm of 1968, the rainfall of 25.96 cm has resulted in a surface runoff of 11.68 cm, thus giving a coefficient of runoff of $\frac{11.68}{25.96} = 0.43$ for the whole catchment. During this flood, there was a wind storm of 80 km/hr blowing over the city of Surat. There was simultaneous high tide in the river. There was heavy storm concentration in the lower catchment. The total loss due to the devastating floods of 1968 was around Rs. 100 lakhs.

In Chapter 15, the magnitudes and return periods (recurrence intervals) of the high floods are determined by the deterministic, probabilistic and stochastic approaches using the annual flood data of the lower Tapti river at Ukai for the 30-years period from 1939 to 1968. The Gumbel's method, based on the theory of extreme values gives a 100-year flood of 49210 cumec and hence this method can be safely adopted in the estimation of design flood for the purpose of safe design of hydraulic structures, while the stochastic approach may give a suitable value of MPF.

1.4 HYDROLOGY AND HYDROLOGIC CYCLE

Hydrology is the science, which deals with the occurrence, distribution and disposal of water on the planet earth; it is the science which deals with the various phases of the hydrologic cycle.

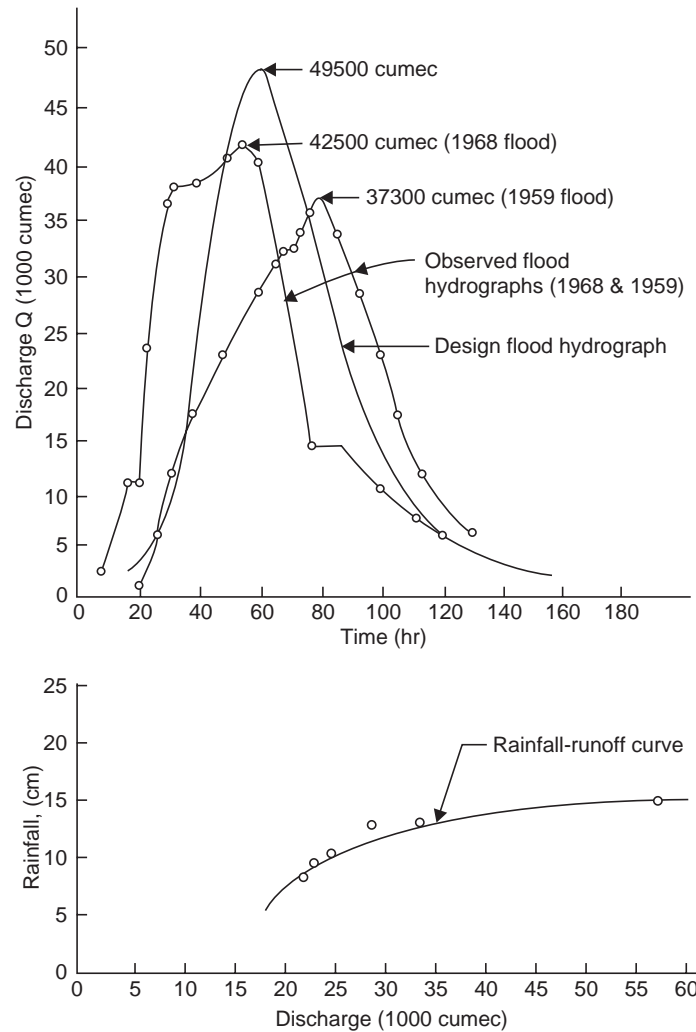

Fig. 1.6 Flood hydrographs of river Tapti at Ukai

Hydrologic cycle is the water transfer cycle, which occurs continuously in nature; the three important phases of the hydrologic cycle are: (a) Evaporation and evapotranspiration (b) precipitation and (c) runoff and is shown in Fig. 1.7. The globe has one-third land and two-thirds ocean. Evaporation from the surfaces of ponds, lakes, reservoirs, ocean surfaces, etc. and transpiration from surface vegetation *i.e.*, from plant leaves of cropped land and forests, etc. take place. These vapours rise to the sky and are condensed at higher altitudes by condensation nuclei and form clouds, resulting in droplet growth. The clouds melt and sometimes burst resulting in precipitation of different forms like rain, snow, hail, sleet, mist, dew and frost. A part of this precipitation flows over the land called runoff and part infiltrates into the soil which builds up the ground water table. The surface runoff joins the streams and the water is stored in reservoirs. A portion of surface runoff and ground water flows back to ocean. Again evaporation starts from the surfaces of lakes, reservoirs and ocean, and the cycle repeats. Of these three phases of the hydrologic cycle, namely, evaporation, precipitation and

runoff, it is the 'runoff phase', which is important to a civil engineer since he is concerned with the storage of surface runoff in tanks and reservoirs for the purposes of irrigation, municipal water supply hydroelectric power etc.

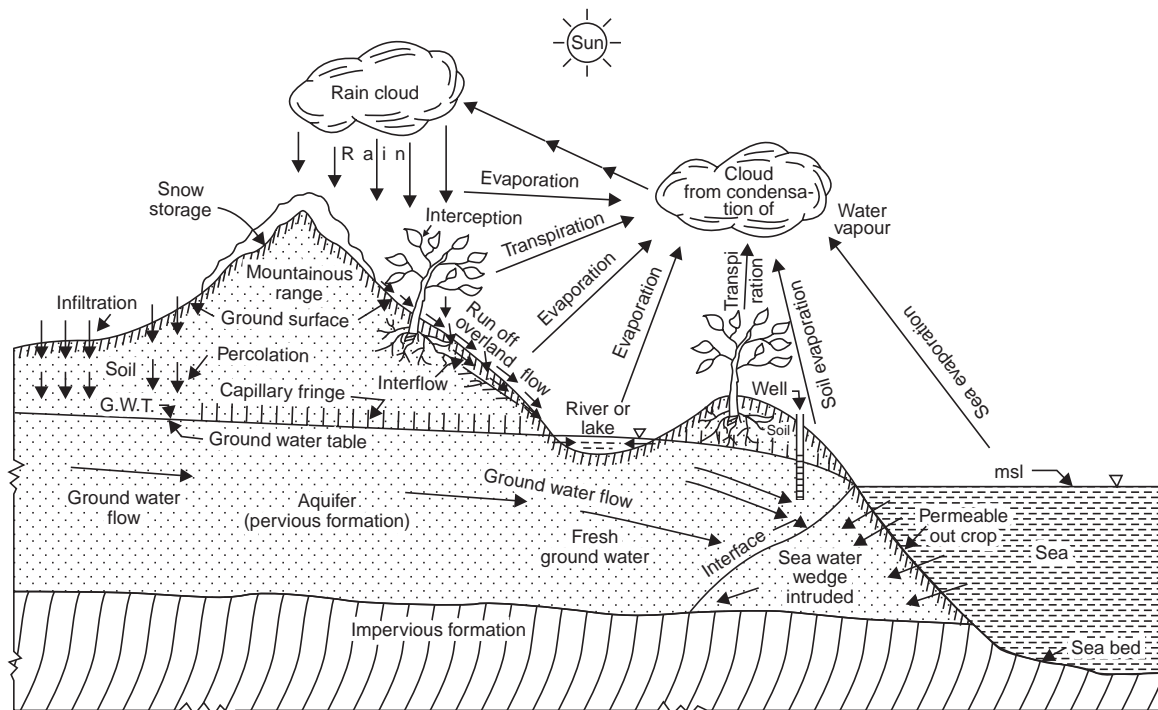

Fig. 1.7 The hydrologic cycle

1.5 FORMS OF PRECIPITATION

- Drizzle — a light steady rain in fine drops (0.5 mm) and intensity <1 mm/hr
- Rain — the condensed water vapour of the atmosphere falling in drops (>0.5 mm, maximum size—6 mm) from the clouds.
- Glaze — freezing of drizzle or rain when they come in contact with cold objects.
- Sleet — frozen rain drops while falling through air at subfreezing temperature.
- Snow — ice crystals resulting from sublimation (*i.e.*, water vapour condenses to ice)
- Snow flakes — ice crystals fused together.
- Hail — small lumps of ice (>5 mm in diameter) formed by alternate freezing and melting, when they are carried up and down in highly turbulent air currents.
- Dew — moisture condensed from the atmosphere in small drops upon cool surfaces.

| | |
|-------|---|
| Frost | — a feathery deposit of ice formed on the ground or on the surface of exposed objects by dew or water vapour that has frozen |
| Fog | — a thin cloud of varying size formed at the surface of the earth by condensation of atmospheric vapour (interfering with visibility) |
| Mist | — a very thin fog |

1.6 SCOPE OF HYDROLOGY

The study of hydrology helps us to know

- (i) the maximum probable flood that may occur at a given site and its frequency; this is required for the safe design of drains and culverts, dams and reservoirs, channels and other flood control structures.
- (ii) the water yield from a basin—its occurrence, quantity and frequency, etc; this is necessary for the design of dams, municipal water supply, water power, river navigation, etc.
- (iii) the ground water development for which a knowledge of the hydrogeology of the area, *i.e.*, of the formation soil, recharge facilities like streams and reservoirs, rainfall pattern, climate, cropping pattern, etc. are required.
- (iv) the maximum intensity of storm and its frequency for the design of a drainage project in the area.

1.7 HYDROLOGICAL DATA

For the analysis and design of any hydrologic project adequate data and length of records are necessary. A hydrologist is often posed with lack of adequate data. The basic hydrological data required are:

- (i) Climatological data
- (ii) Hydrometeorological data like temperature, wind velocity, humidity, etc.
- (iii) Precipitation records
- (iv) Stream-flow records
- (v) Seasonal fluctuation of ground water table or piezometric heads
- (vi) Evaporation data
- (vii) Cropping pattern, crops and their consumptive use
- (viii) Water quality data of surface streams and ground water
- (ix) Geomorphologic studies of the basin, like area, shape and slope of the basin, mean and median elevation, mean temperature (as well as highest and lowest temperature recorded) and other physiographic characteristics of the basin; stream density and drainage density; tanks and reservoirs
- (x) Hydrometeorological characteristics of basin:
 - (i) a.a.r., long term precipitation, space average over the basin using isohyets and several other methods (Rainbird, 1968)
 - (ii) Depth-area-duration (DAD) curves for critical storms (station equipped with self-recording raingauges).

- (iii) Isohyetal maps—Isohyets may be drawn for long-term average, annual and monthly precipitation for individual years and months
- (iv) Cropping pattern—crops and their seasons
- (v) Daily, monthly and annual evaporation from water surfaces in the basin
- (vi) Water balance studies of the basin
- (vii) Chronic problems in the basin due to a flood-menacing river (like Tapti or Tapi in central India) or siltmenacing river (like Tungabhadra in Karnataka)
- (vii) Soil conservation and methods of flood control

1.8 HYDROLOGIC EQUATION

The hydrologic equation is simply the statement of the law of conservation of matter and is given by

$$I = O + \Delta S \quad \dots(1.1)$$

where

I = inflow

O = outflow

ΔS = change in storage

This equation states that during a given period, the total inflow into a given area must equal the total outflow from the area plus the change in storage. While solving this equation, the ground water is considered as an integral part of the surface water and it is the subsurface inflow and outflow that pose problems in the water balance studies of a basin.

QUIZ I

I Choose the correct statement/s in the following:

- 1 The hydrological cycle
 - (i) has beginning but does not end
 - (ii) has both beginning and end
 - (iii) occurs continuously in nature
 - (iv) is a water transfer cycle
 - (v) has three phases—precipitation, evaporation and runoff
- 2 Hydrology deals with
 - (i) occurrence of water and formation of snow
 - (ii) movement of water on earth and water vapour in atmosphere
 - (iii) occurrence of floods and droughts
 - (iv) consumptive use of crops and crop planning
 - (v) prevention of drought
 - (vi) the hydrologic cycle
- 3 Hydrologic studies are made
 - (i) to determine MPF
 - (ii) to determine design flood for spillways and bridges
 - (iii) to assess the ground water potential of a basin

(iv) for the preparation of land drainage schemes

(v) to determine the hydro-power potential

(iv) for irrigation and crop planning

(vii) for all the above

4 The hydrologic equation states that

(i) the inflow into the basin is equal to the outflow from the basin at any instant

(ii) the difference between inflow and outflow is the storage

(iii) subsurface inflow is equal to the subsurface outflow

(iv) the water balance over the basin = Σ inflow — Σ outflow

II Match the items in 'A' with items in 'B'

A

(i) Runoff

(ii) Snow, hail

(iii) Hydrology

(iv) Hydrologic cycle

(v) Evaporation, precipitation and runoff

(vi) Hydrologic equation

B

(a) Deals with hydrologic cycle

(b) Water transfer cycle

(c) Important phase of hydrologic cycle

(d) Forms of precipitation

(e) Law of conservation of matter

(f) Three phases of hydrologic cycle

QUESTIONS

- 1 Explain the hydraulic cycle in nature with the help of a neat sketch, indicating its various phases.
- 2 What are the basic data required for hydrological studies? Name the agencies from which the data can be obtained?
- 3 What is the function of hydrology in water resources development? What are the basic hydrological requirements for a river basin development?
- 4 Explain 'hydrologic equation'.

Chapter 2

PRECIPITATION

The **precipitation** in the country (India) is mainly in the form of rain fall though there is appreciable snowfall at high altitudes in the Himalayan range and most of the rivers in north India are perennial since they receive snow-melt in summer (when there is no rainfall).

2.1 TYPES OF PRECIPITATION

The precipitation may be due to

(i) Thermal convection (convictional precipitation)—This type of precipitation is in the form of local whirling thunder storms and is typical of the tropics. The air close to the warm earth gets heated and rises due to its low density, cools adiabatically to form a cauliflower shaped cloud, which finally bursts into a thunder storm. When accompanied by destructive winds, they are called ‘tornados’.

(ii) Conflict between two air masses (frontal precipitation)—When two air masses due to contrasting temperatures and densities clash with each other, condensation and precipitation occur at the surface of contact, Fig. 2.1. This surface of contact is called a ‘front’ or ‘frontal surface’. If a cold air mass drives out a warm air mass’ it is called a ‘cold front’ and if a warm air mass replaces the retreating cold air mass, it is called a ‘warm front’. On the other hand, if the two air masses are drawn simultaneously towards a low pressure area, the front developed is stationary and is called a ‘stationary front’. Cold front causes intense precipitation on comparatively small areas, while the precipitation due to warm front is less intense but is spread over a comparatively larger area. Cold fronts move faster than warm fronts and usually overtake them, the frontal surfaces of cold and warm air sliding against each other. This phenomenon is called ‘occlusion’ and the resulting frontal surface is called an ‘occluded front’.

(iii) Orographic lifting (orographic precipitation)—The mechanical lifting of moist air over mountain barriers, causes heavy precipitation on the windward side (Fig. 2.2). For example Cherrapunji in the Himalayan range and Agumbe in the western Ghats of south India get very heavy orographic precipitation of 1250 cm and 900 cm (average annual rainfall), respectively.

(iv) Cyclonic (cyclonic precipitation)—This type of precipitation is due to lifting of moist air converging into a low pressure belt, *i.e.*, due to pressure differences created by the unequal heating of the earth’s surface. Here the winds blow spirally inward counterclockwise in the northern hemisphere and clockwise in the southern hemisphere. There are two main types of cyclones—tropical cyclone (also called hurricane or typhoon) of comparatively small diameter of 300-1500 km causing high wind velocity and heavy precipitation, and the extra-tropical cyclone of large diameter up to 3000 km causing wide spread frontal type precipitation.

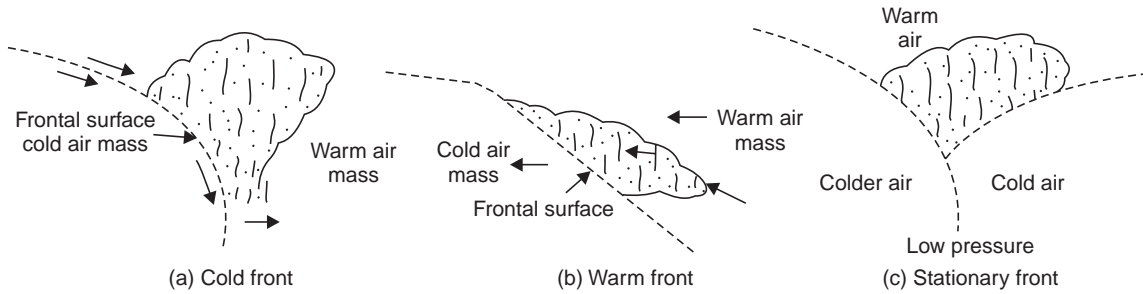

Fig. 2.1 Frontal precipitation

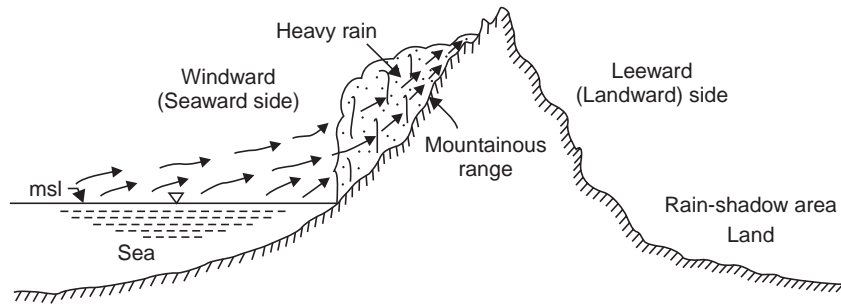

Fig. 2.2 Orographic precipitation

2.2 MEASUREMENT OF PRECIPITATION

Rainfall may be measured by a network of rain gauges which may either be of non-recording or recording type.

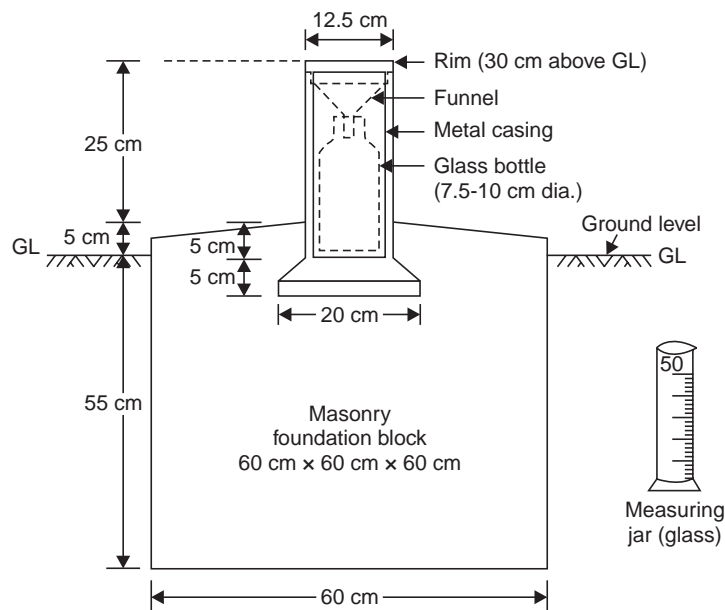

Fig. 2.3 Symon's rain gauge

The non-recording rain gauge used in India is the Symon's rain gauge (Fig. 2.3). It consists of a funnel with a circular rim of 12.7 cm diameter and a glass bottle as a receiver. The cylindrical metal casing is fixed vertically to the masonry foundation with the level rim 30.5 cm above the ground surface. The rain falling into the funnel is collected in the receiver and is measured in a special measuring glass graduated in mm of rainfall; when full it can measure 1.25 cm of rain.

The rainfall is measured every day at 08.30 hours IST. During heavy rains, it must be measured three or four times in the day, lest the receiver fill and overflow, but the last measurement should be at 08.30 hours IST and the sum total of all the measurements during the previous 24 hours entered as the rainfall of the day in the register. Usually, rainfall measurements are made at 08.30 hr IST and sometimes at 17.30 hr IST also. Thus the non-recording or the Symon's rain gauge gives only the total depth of rainfall for the previous 24 hours (*i.e.*, daily rainfall) and does not give the intensity and duration of rainfall during different time intervals of the day.

It is often desirable to protect the gauge from being damaged by cattle and for this purpose a barbed wire fence may be erected around it.

Recording Rain Gauge

This is also called self-recording, automatic or integrating rain gauge. This type of rain gauge Figs. 2.4, 2.5 and 2.6, has an automatic mechanical arrangement consisting of a clockwork, a drum with a graph paper fixed around it and a pencil point, which draws the mass curve of rainfall Fig. 2.7. From this mass curve, the depth of rainfall in a given time, the rate or intensity of rainfall at any instant during a storm, time of onset and cessation of rainfall, can be determined. The gauge is installed on a concrete or masonry platform 45 cm square in the observatory enclosure by the side of the ordinary rain gauge at a distance of 2-3 m from it. The gauge is so installed that the rim of the funnel is horizontal and at a height of exactly 75 cm above ground surface. The self-recording rain gauge is generally used in conjunction with an ordinary rain gauge exposed close by, for use as standard, by means of which the readings of the recording rain gauge can be checked and if necessary adjusted.

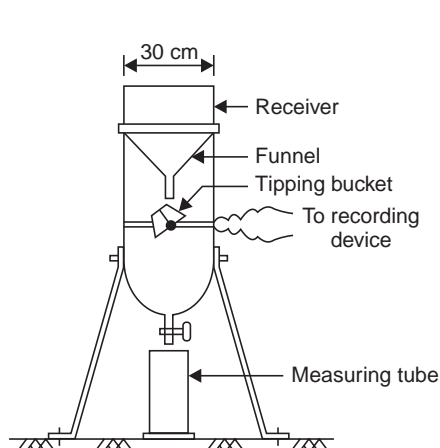

Fig. 2.4 Tipping bucket gauge

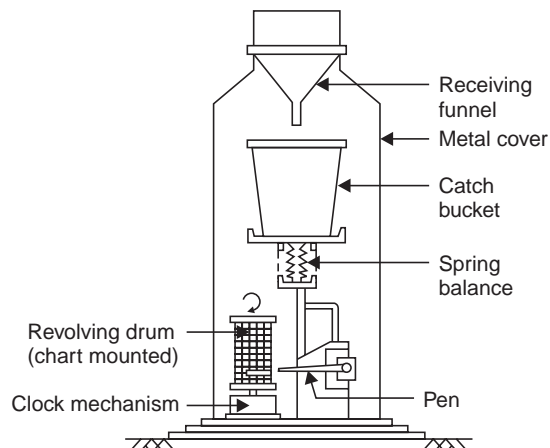

Fig. 2.5 Weighing type rain gauge

There are three types of recording rain gauges—tipping bucket gauge, weighing gauge and float gauge.

Tipping bucket rain gauge. This consists of a cylindrical receiver 30 cm diameter with a funnel inside (Fig. 2.4). Just below the funnel a pair of tipping buckets is pivoted such that when one of the bucket receives a rainfall of 0.25 mm it tips and empties into a tank below, while the other bucket takes its position and the process is repeated. The tipping of the bucket actuates an electric circuit which causes a pen to move on a chart wrapped round a drum which revolves by a clock mechanism. This type cannot record snow.

Weighing type rain gauge. In this type of rain-gauge, when a certain weight of rainfall is collected in a tank, which rests on a spring-lever balance, it makes a pen to move on a chart wrapped round a clockdriven drum (Fig. 2.5). The rotation of the drum sets the time scale while the vertical motion of the pen records the cumulative precipitation.

Float type rain gauge. In this type, as the rain is collected in a float chamber, the float moves up which makes a pen to move on a chart wrapped round a clock driven drum (Fig. 2.6). When the float chamber fills up, the water siphons out automatically through a siphon tube kept in an interconnected siphon chamber. The clockwork revolves the drum once in 24 hours. The clock mechanism needs rewinding once in a week when the chart wrapped round the drum is also replaced. This type of gauge is used by IMD.

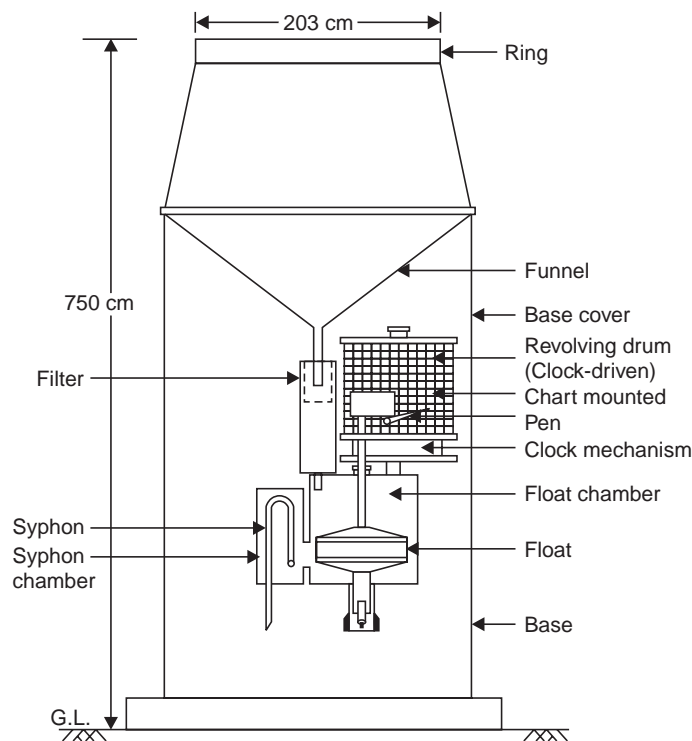

Fig. 2.6 Float type rain gauge

The weighing and float type rain gauges can store a moderate snow fall which the operator can weigh or melt and record the equivalent depth of rain. The snow can be melted in

the gauge itself (as it gets collected there) by a heating system fitted to it or by placing in the gauge certain chemicals such as Calcium Chloride, ethylene glycol, etc.

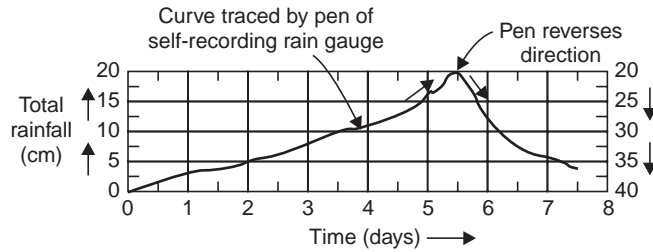

Fig. 2.7 Mass curve of rainfall

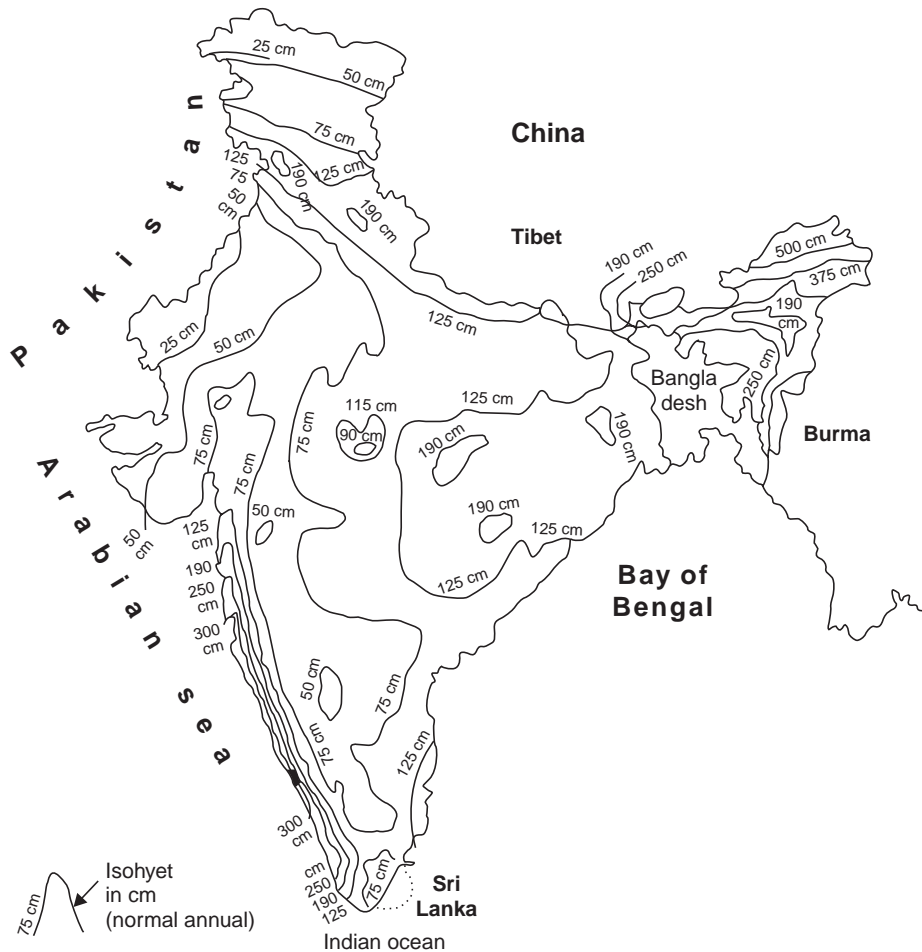

Fig. 2.8 Isohyetal map of India

Automatic-radio-reporting rain-gauge

This type of rain-gauge is used in mountainous areas, which are not easily accessible to collect the rainfall data manually. As in the tipping bucket gauge, when the buckets fill and tip, they

give electric pulses equal in number to the mm of rainfall collected which are coded into messages and impressed on a transmitter during broadcast. At the receiving station, these coded signals are picked up by UHF receiver. This type of rain gauge was installed at the Koyna hydro-electric project in June 1966 by IMD, Poona and is working satisfactorily.

2.3 RADARS

The application of radars in the study of storm mechanics, *i.e.* the areal extent, orientation and movement of rain storms, is of great use. The radar signals reflected by the rain are helpful in determining the magnitude of storm precipitation and its areal distribution. This method is usually used to supplement data obtained from a network of rain gauges. The IMD has a well established radar network for the detection of thunder storms and six cyclone warning radars, on the east coast at Chennai, Kolkata, Paradeep, Vishakapatnam, Machalipatnam and Karaikal. See the picture given on facing page.

Location of rain-gauges—Rain-gauges must be so located as to avoid exposure to wind effect or interception by trees or buildings nearby.

The best location may be an open plane ground like an airport.

The rainfall records are maintained by one or more of the following departments:

- Indian Meteorological Department (IMD)
- Public Works Department (PWD)
- Agricultural Department
- Revenue Department
- Forest Department, etc.

2.4 RAIN-GAUGE DENSITY

The following figures give a guideline as to the number of rain-gauges to be erected in a given area or what is termed as 'rain-gauge density'

| <i>Area</i> | <i>Rain-gauge density</i> |
|-------------------------------------|---|
| Plains | 1 in 520 km ² |
| Elevated regions | 1 in 260-390 km ² |
| Hilly and very heavy rainfall areas | 1 in 130 Km ² preferably with 10% of the rain-gauge stations equipped with the self recording type |

In India, on an average, there is 1 rain-gauge station for every 500 km², while in more developed countries, it is 1 stn. for 100 km².

The length of record (*i.e.*, the number of years) needed to obtain a stable frequency distribution of rainfall may be recommended as follows:

| Catchment layout: | Islands | Shore | Plain areas | Mountainous regions |
|-------------------|---------|-------|-------------|---------------------|
| No. of years: | 30 | 40 | 40 | 50 |

The mean of yearly rainfall observed for a period of 35 consecutive years is called the average annual rainfall (a.a.r.) as used in India. The a.a.r. of a place depends upon: (*i*) distance

from the ocean, (ii) direction of the prevailing winds, (iii) the mean annual temperature, (iv) altitude of the place, and (v) its topography. The ratio of rainfall in a particular year to the a.a.r. is called the 'index of wetness'. There may be wet (good), dry (bad or difficult) and normal (average) years as the rainfall is greater, less than, or equal to a.a.r., respectively. For example, an index of wetness of 60% in a particular year indicates a rainfall deficiency of 40%.



A picture of the cyclonic storm as seen by the satellite at 3:30 p.m. showing a dense cloud mass over northern Tamil Nadu and southern Andhra Pradesh

A line joining the places having the same a.a.r. is called an 'isohyet'; see the isohyetal map of India Fig. 2.8.

If the a.a.r. < 40 cm, it is arid climate, 40 to 75 cm semi-arid climate and > 75 cm humid climate. In an arid climate, a drought is a normal state of affairs, and while calculating runoff from an arid catchment each fall of rain has to be considered as a separate unit. In a semi-arid climate, a drought occurs at least once a year except in abnormal years, and in a humid or standard climate, a drought does not occur in ordinary years. All these three classes of climate are found in India (see also Chapter 12).

2.5 ESTIMATES OF MISSING DATA AND ADJUSTMENT OF RECORDS

For frequency analysis of rainfall data, a sufficiently long record is required. It may so happen that a particular rain-gauge is not operative for part of a month or so (since it is broken or for some other reason), when it becomes necessary to supplement the missing record by one of the following methods:

(i) Station-year method—In this method, the records of two or more stations are combined into one long record provided station records are independent and the areas in which the stations are located are climatologically the same. The missing record at a station in a particular year may be found by the ratio of averages or by graphical comparison. For example, in a certain year the total rainfall of station *A* is 75 cm and for the neighbouring station *B*, there is no record. But if the a.a.r. at *A* and *B* are 70 cm and 80 cm, respectively, the missing year's rainfall at *B* (say, P_B) can be found by simple proportion as:

$$\frac{75}{70} = \frac{P_B}{80} \quad \therefore P_B = 85.7 \text{ cm}$$

This result may again be checked with reference to another neighbouring station *C*.

(ii) By simple proportion (normal ratio method)—This method is illustrated by the following example.

Example 2.1 Rain-gauge station *D* was inoperative for part of a month during which a storm occurred. The storm rainfall recorded in the three surrounding stations *A*, *B* and *C* were 8.5, 6.7 and 9.0 cm, respectively. If the a.a.r for the stations are 75, 84, 70 and 90 cm, respectively, estimate the storm rainfall at station *D*.

Solution By equating the ratios of storm rainfall to the a.a.r. at each station, the storm rainfall at station *D* (P_D) is estimated as

$$\frac{8.5}{75} = \frac{6.7}{84} = \frac{9.0}{70} = \frac{P_D}{90}$$

$$\therefore \text{The average value of } P_D = \frac{1}{3} \left[\frac{8.5}{75} \times 90 + \frac{6.7}{84} \times 90 + \frac{9.0}{70} \times 90 \right] = \mathbf{9.65 \text{ cm}}$$

(iii) Double-mass analysis—The trend of the rainfall records at a station may slightly change after some years due to a change in the environment (or exposure) of a station either due to coming of a new building, fence, planting of trees or cutting of forest nearby, which affect the catch of the gauge due to change in the wind pattern or exposure. The consistency of records at the station in question (say, *X*) is tested by a double mass curve by plotting the cumulative annual (or seasonal) rainfall at station *X* against the concurrent cumulative values of mean annual (or seasonal) rainfall for a group of surrounding stations, for the number of years of record (Fig. 2.9). From the plot, the year in which a change in regime (or environment) has occurred is indicated by the change in slope of the straight line plot. The rainfall records of the station *x* are adjusted by multiplying the recorded values of rainfall by the ratio of slopes of the straight lines before and after change in environment.

Example 2.2 The annual rainfall at station *X* and the average annual rainfall at 18 surrounding stations are given below. Check the consistency of the record at station *X* and determine the year in which a change in regime has occurred. State how you are going to adjust the records for the change in regime. Determine the a.a.r. for the period 1952-1970 for the changed regime.

| Year | Annual rainfall (cm) | |
|------|----------------------|-----------------|
| | Stn. <i>X</i> | 18-stn. average |
| 1952 | 30.5 | 22.8 |
| 1953 | 38.9 | 35.0 |
| 1954 | 43.7 | 30.2 |
| 1955 | 32.2 | 27.4 |

(contd.)...

| | | |
|------|------|------|
| 1956 | 27.4 | 25.2 |
| 1957 | 32.0 | 28.2 |
| 1958 | 49.3 | 36.1 |
| 1959 | 28.4 | 18.4 |
| 1960 | 24.6 | 25.1 |
| 1961 | 21.8 | 23.6 |
| 1962 | 28.2 | 33.3 |
| 1963 | 17.3 | 23.4 |
| 1964 | 22.3 | 36.0 |
| 1965 | 28.4 | 31.2 |
| 1966 | 24.1 | 23.1 |
| 1967 | 26.9 | 23.4 |
| 1968 | 20.6 | 23.1 |
| 1969 | 29.5 | 33.2 |
| 1970 | 28.4 | 26.4 |

Solution

| <i>Year</i> | <i>Cumulative Annual rainfall (cm)</i> | |
|-------------|--|------------------------|
| | <i>Stn. X</i> | <i>18-stn. average</i> |
| 1952 | 30.5 | 22.8 |
| 1953 | 69.4 | 57.8 |
| 1954 | 113.1 | 88.0 |
| 1955 | 145.3 | 115.4 |
| 1956 | 172.7 | 140.6 |
| 1957 | 204.7 | 168.8 |
| 1958 | 254.0 | 204.9 |
| 1959 | 282.4 | 233.3 |
| 1960 | 307.0 | 258.4 |
| 1961 | 328.8 | 282.0 |
| 1962 | 357.0 | 315.3 |
| 1963 | 374.3 | 338.7 |
| 1964 | 396.6 | 374.7 |
| 1965 | 425.0 | 405.9 |
| 1966 | 449.1 | 429.0 |
| 1967 | 476.0 | 452.4 |
| 1968 | 496.6 | 475.5 |
| 1969 | 526.1 | 508.7 |
| 1970 | 554.5 | 535.1 |

The above cumulative rainfalls are plotted as shown in Fig. 2.9. It can be seen from the figure that there is a distinct change in slope in the year 1958, which indicates that a change in regime (exposure) has occurred in the year 1958. To make the records prior to 1958 comparable

with those after change in regime has occurred, the earlier records have to be adjusted by multiplying by the ratio of slopes m_2/m_1 i.e., $0.9/1.25$.

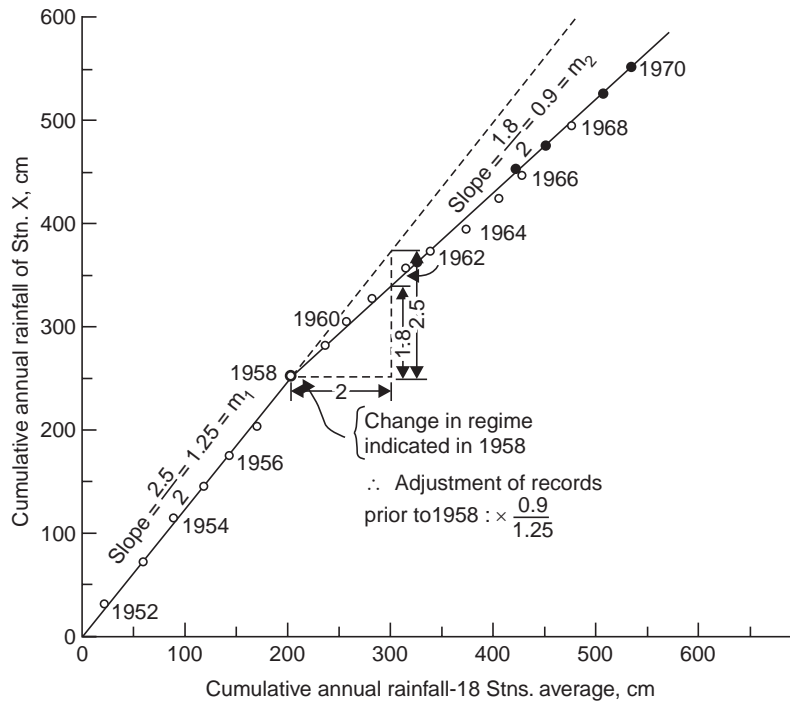

Fig. 2.9 Double mass analysis Example 2.2

$$\begin{aligned} \text{Cumulative rainfall 1958-1970} \\ &= 554.5 - 204.7 &&= 349.8 \text{ cm} \end{aligned}$$

$$\begin{aligned} \text{Cumulative rainfall 1952-1957} \\ \text{adjusted for changed environment} \\ &= 204.7 \times \frac{0.9}{1.25} &&= 147.6 \text{ cm} \end{aligned}$$

$$\begin{aligned} \text{Cumulative rainfall 1952-1970} \\ \text{(for the current environment)} &&&= 497.4 \text{ cm} \end{aligned}$$

$$\begin{aligned} \text{a.a.r. adjusted for the current regime} \\ &= \frac{497.4 \text{ cm}}{19 \text{ years}} &&= 26.2 \text{ cm.} \end{aligned}$$

2.6 MEAN AREAL DEPTH OF PRECIPITATION (P_{ave})

Point rainfall—It is the rainfall at a single station. For small areas less than 50 km^2 , point rainfall may be taken as the average depth over the area. In large areas, there will be a network of rain-gauge stations. As the rainfall over a large area is not uniform, the average depth of rainfall over the area is determined by one of the following three methods:

(i) **Arithmetic average method**—It is obtained by simply averaging arithmetically the amounts of rainfall at the individual rain-gauge stations in the area, i.e.,

$$P_{ave} = \frac{\Sigma P_1}{n} \quad \dots(2.1)$$

where P_{ave} = average depth of rainfall over the area

ΣP_1 = sum of rainfall amounts at individual rain-gauge stations

n = number of rain-gauge stations in the area

This method is fast and simple and yields good estimates in flat country if the gauges are uniformly distributed and the rainfall at different stations do not vary very widely from the mean. These limitations can be partially overcome if topographic influences and aerial representativity are considered in the selection of gauge sites.

(ii) Thiessen polygon method—This method attempts to allow for non-uniform distribution of gauges by providing a weighting factor for each gauge. The stations are plotted on a base map and are connected by straight lines. Perpendicular bisectors are drawn to the straight lines, joining adjacent stations to form polygons, known as Thiessen polygons (Fig. 2.10). Each polygon area is assumed to be influenced by the raingauge station inside it, *i.e.*, if P_1, P_2, P_3, \dots are the rainfalls at the individual stations, and A_1, A_2, A_3, \dots are the areas of the polygons surrounding these stations, (influence areas) respectively, the average depth of rainfall for the entire basin is given by

$$P_{ave} = \frac{\Sigma A_1 P_1}{\Sigma A_1} \quad \dots(2.2)$$

where $\Sigma A_1 = A$ = total area of the basin.

The results obtained are usually more accurate than those obtained by simple arithmetic averaging. The gauges should be properly located over the catchment to get regular shaped polygons. However, one of the serious limitations of the Thiessen method is its non-flexibility since a new Thiessen diagram has to be constructed every time if there is a change in the raingauge network.

(iii) The isohyetal method—In this method, the point rainfalls are plotted on a suitable base map and the lines of equal rainfall (isohyets) are drawn giving consideration to orographic effects and storm morphology, Fig. 2.11. The average rainfall between the successive isohyets taken as the average of the two isohyetal values are weighted with the area between the isohyets, added up and divided by the total area which gives the average depth of rainfall over the entire basin, *i.e.*,

$$P_{ave} = \frac{\Sigma A_{1-2} P_{1-2}}{\Sigma A_{1-2}} \quad \dots(2.3)$$

where A_{1-2} = area between the two successive isohyets P_1 and P_2

$$P_{1-2} = \frac{P_1 + P_2}{2}$$

$\Sigma A_{1-2} = A$ = total area of the basin.

This method if analysed properly gives the best results.

Example 2.3 Point rainfalls due to a storm at several rain-gauge stations in a basin are shown in Fig. 2.10. Determine the mean areal depth of rainfall over the basin by the three methods.

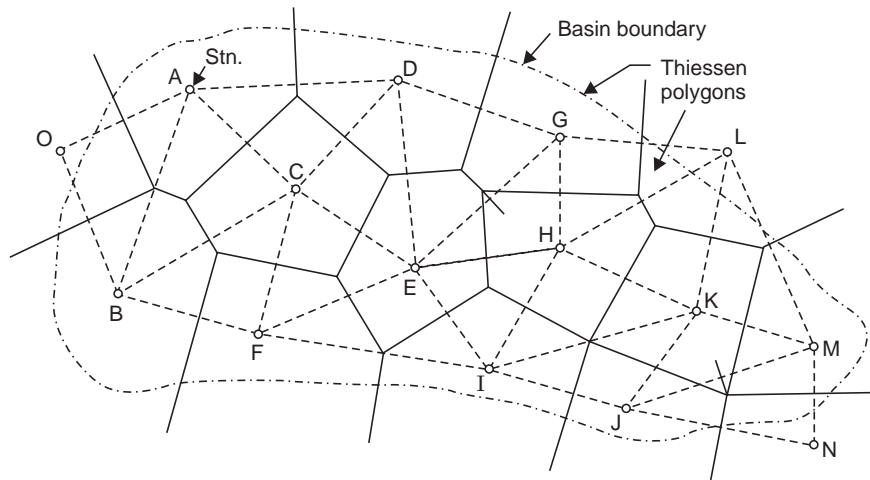

Fig. 2.10 Thiessen polygon method, Example 2.3

Solution (i) Arithmetic average method

$$P_{ave} = \frac{\Sigma P_1}{n} = \frac{1331 \text{ cm}}{15 \text{ stn.}} = 8.87 \text{ cm}$$

ΣP_1 = sum of the 15 station rainfalls.

(ii) Thiessen polygon method—The Thiessen polygons are constructed as shown in Fig. 2.10 and the polygonal areas are planimetered and the mean areal depth of rainfall is worked out below:

| Station | Rainfall recorded, P_1 (cm) | Area of influential polygon, A_1 (km^2) | Product (2) \times (3) $A_1 P_1$ ($\text{km}^2\text{-cm}$) | Mean areal depth of rainfall |
|---------|-------------------------------|--|--|--|
| 1 | 2 | 3 | 4 | 5 |
| A | 8.8 | 570 | 5016 | $P_{ave} = \frac{\Sigma A_1 P_1}{\Sigma A_1}$ $= \frac{66714}{7180}$ $= 9.30 \text{ cm}$ |
| B | 7.6 | 920 | 6992 | |
| C | 10.8 | 720 | 7776 | |
| D | 9.2 | 620 | 5704 | |
| E | 13.8 | 520 | 7176 | |
| F | 10.4 | 550 | 5720 | |
| G | 8.5 | 400 | 3400 | |
| H | 10.5 | 650 | 6825 | |
| I | 11.2 | 500 | 5600 | |
| J | 9.5 | 350 | 3325 | |
| K | 7.8 | 520 | 4056 | |
| L | 5.2 | 250 | 1300 | |
| M | 5.6 | 350 | 1960 | |

(contd.)...

| | | | |
|----------|----------------|----------------------|---------------------------|
| N | 6.8 | 100 | 680 |
| O | 7.4 | 160 | 1184 |
| Total | 1331 cm | 7180 km ² | 66714 km ² -cm |
| $n = 15$ | $= \Sigma P_1$ | $= \Sigma A_1$ | $\Sigma A_1 P_1$ |

(iii) Isohyetal method—The isohyets are drawn as shown in Fig. 2.11 and the mean areal depth of rainfall is worked out below:

| Zone | Isohyets (cm) | Mean isohyetal value, P_{1-2} (cm) | Area between isohyets, A_{1-2} (km ²) | Product (3) × (4) (km ² -cm) | Mean areal depth of rainfall (cm) |
|-------|------------------|--|---|---|---|
| 1 | 2 | 3 | 4 | 5 | 6 |
| I | <6 | 5.4 | 410 | 2214 | $P_{ave} =$ |
| II | 6-8 | 7 | 900 | 6300 | $\frac{\Sigma A_{1-2} P_{1-2}}{\Sigma A_{1-2}}$ |
| III | 8-10 | 9 | 2850 | 25650 | |
| IV | 10-12 | 11 | 1750 | 19250 | $\frac{66754}{7180}$ |
| V | >12 | 12.8 | 720 | 9220 | $=$ |
| VI | <8 | 7.5 | 550 | 4120 | $= \mathbf{930 \text{ cm}}$ |
| Total | | | 7180 km ² $= \Sigma A_{1-2}$ | 66754 km ² -cm $= \Sigma A_{1-2} \cdot P_{1-2}$ | |

Example 2.3 (a) The area shown in Fig. P (2.3a) is composed of a square plus an equilateral triangular plot of side 10 km. The annual precipitations at the rain-gauge stations located at the four corners and centre of the square plot and apex of the triangular plot are indicated in figure. Find the mean precipitation over the area by Thiessen polygon method, and compare with the arithmetic mean.

Solution The Thiessen polygon is constructed by drawing perpendicular bisectors to the lines joining the rain-gauge stations as shown in Fig. P (2.3a). The weighted mean precipitation is computed in the following table:

$$\text{Area of square plot} = 10 \times 10 = 100 \text{ km}^2$$

$$\text{Area of inner square plot} = \frac{10}{\sqrt{2}} \times \frac{10}{\sqrt{2}} = 50 \text{ km}^2$$

$$\text{Difference} = 50 \text{ km}^2$$

$$\text{Area of each corner triangle in the square plot} = \frac{56}{4} = 12.5 \text{ km}^2$$

$$\frac{1}{3} \text{ area of the equilateral triangular plot} = \frac{1}{3} \left(\frac{1}{2} \times 10 \times 10 \sin 60 \right)$$

$$= \frac{25}{\sqrt{3}} = 14.4 \text{ km}^2$$

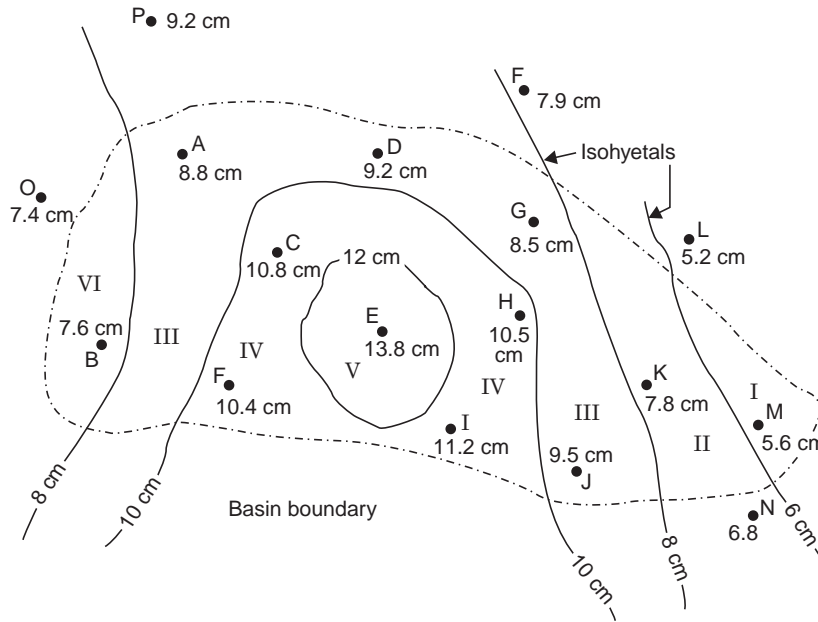

Fig. 2.11 Isohyetal method, Example 2.3

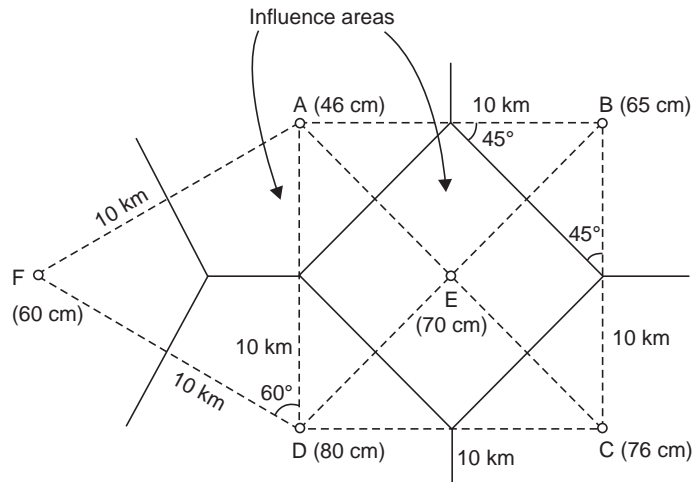

Fig. P(2.3a)

| Station | Area, A (km ²) | Precipitation P (cm) | A × P (km ² -cm) | P _{ave} (cm) |
|---------|----------------------------|----------------------|-----------------------------|-----------------------|
| A | (12.5 + 14.4) = 26.9 | 46 | 1238 | |
| B | 12.5 | 65 | 813 | |

(contd.)...

| | | | | |
|---------|--|------------------|----------------------|---------------------------------|
| C | 12.5 | 76 | 950 | $= \frac{\Sigma A.P}{\Sigma A}$ |
| D | (12.5 + 14.4) | 80 | 2152 | $= \frac{9517}{143.2}$ |
| | = 26.9 | | | = 66.3 cm |
| E | 50 | 70 | 3500 | |
| F | 14.4 | 60 | 864 | |
| $n = 6$ | $\Sigma A = 143.2$ $= 100 + 25\sqrt{3}$ as a check | $\Sigma P = 397$ | $\Sigma A.P. = 9517$ | |

$$\text{Arithmetic mean} = \frac{\Sigma P}{n} = \frac{397}{6} = \mathbf{66.17 \text{ cm}}$$

which compares fairly with the weighted mean.

2.7 OPTIMUM RAIN-GAUGE NETWORK DESIGN

The aim of the optimum rain-gauge network design is to obtain all quantitative data averages and extremes that define the statistical distribution of the hydrometeorological elements, with sufficient accuracy for practical purposes. When the mean areal depth of rainfall is calculated by the simple arithmetic average, the optimum number of rain-gauge stations to be established in a given basin is given by the equation (IS, 1968)

$$N = \left(\frac{C_v}{p} \right)^2 \quad \dots(2.4)$$

where N = optimum number of rain-gauge stations to be established in the basin

C_v = Coefficient of variation of the rainfall of the existing rain gauge stations (say, n)

p = desired degree of percentage error in the estimate of the average depth of rainfall over the basin.

The number of additional rain-gauge stations ($N-n$) should be distributed in the different zones (caused by isohyets) in proportion to their areas, *i.e.*, depending upon the spatial distribution of the existing rain-gauge stations and the variability of the rainfall over the basin.

Saturated Network Design

If the project is very important, the rainfall has to be estimated with great accuracy; then a network of rain-gauge stations should be so set up that any addition of rain-gauge stations will not appreciably alter the average depth of rainfall estimated. Such a network is referred to as a saturated network.

Example 2.4 For the basin shown in Fig. 2.12, the normal annual rainfall depths recorded and the isohyets are given. Determine the optimum number of rain-gauge stations to be established in the basin if it is desired to limit the error in the mean value of rainfall to 10%. Indicate how you are going to distribute the additional rain-gauge stations required, if any. What is the percentage accuracy of the existing network in the estimation of the average depth of rainfall over the basin ?

Solution

| Station | Normal annual rainfall, x (cm) | Difference $(x - \bar{x})$ | (Difference) ² $(x - \bar{x})^2$ | Statistical parameters \bar{x}, σ, C_v |
|---------|----------------------------------|----------------------------|---|---|
| A | 88 | - 4.8 | 23.0 | $\bar{x} = \frac{\Sigma x}{n} = \frac{464}{5}$ = 92.8 cm |
| B | 104 | 11.2 | 125.4 | |
| C | 138 | 45.2 | 2040.0 | $\sigma = \sqrt{\frac{\Sigma(x - \bar{x})^2}{n - 1}}$ = $\sqrt{\frac{3767.4}{5 - 1}} = 30.7$ |
| D | 78 | - 14.8 | 219.0 | |
| E | 56 | - 36.8 | 1360.0 | |
| $n = 5$ | $\Sigma x = 464$ | | $\Sigma(x - \bar{x})^2 = 3767.4$ | $C_v = \frac{\sigma}{\bar{x}} = \frac{30.7}{92.8} \times 100$ = 33.1% |

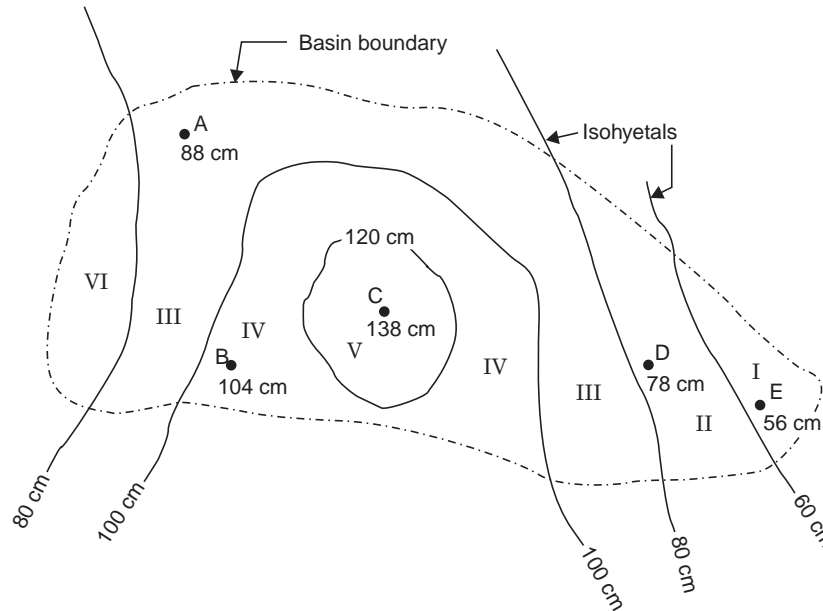
**Fig. 2.12** Isohyetal map, Example 2.4

Note: \bar{x} = Arithmetic mean, σ = standard deviation.

The optimum number of rain-gauge stations to limit the error in the mean value of rainfall to $p = 10\%$.

$$N = \left(\frac{C_v}{p} \right)^2 = \left(\frac{33.1}{10} \right)^2 = 11$$

\therefore Additional rain-gauge stations to be established = $\dot{N} - n = 11 - 5 = 6$

The additional six rain-gauge stations have to be distributed in proportion to the areas between the isohyets as shown below:

| <i>Zone</i> | <i>I</i> | <i>II</i> | <i>III</i> | <i>IV</i> | <i>V</i> | <i>VI</i> | <i>Total</i> |
|------------------------------|----------|-----------|------------|-----------|----------|-----------|--------------|
| Area (Km ²) | 410 | 900 | 2850 | 1750 | 720 | 550 | 7180 |
| Area, as decimal | 0.06 | 0.12 | 0.40 | 0.24 | 0.10 | 0.08 | 1.00 |
| N × Area in decimal (N = 11) | 0.66 | 1.32 | 4.4 | 2.64 | 1.1 | 0.88 | |
| Rounded as | 1 | 1 | 4 | 3 | 1 | 1 | 11 |
| Rain-gauges existing | 1 | 1 | 1 | 1 | 1 | — | 5 |
| Additional rain gauges | — | — | 3 | 2 | — | 1 | 6 |

These additional rain-gauges have to be spatially distributed between the different isohyets after considering the relative distances between rain-gauge stations, their accessibility, personnel required for making observations, discharge sites, etc.

The percentage error p in the estimation of average depth of rainfall in the existing network,

$$p = \frac{C_v}{\sqrt{N}}, \text{ putting } N = n$$

$$P = \frac{33.1}{\sqrt{5}} = 14.8\%$$

Or, the percentage accuracy = **85.2%**

2.8 DEPTH-AREA-DURATION (DAD) CURVES

Rainfall rarely occurs uniformly over a large area; variations in intensity and total depth of fall occur from the centres to the peripheries of storms. From Fig. 2.13 it can be seen that the average depth of rainfall decreases from the maximum as the area considered increases. The average depths of rainfall are plotted against the areas up to the encompassing isohyets. It may be necessary in some cases to study alternative isohyetal maps to establish maximum 1-day, 2-day, 3 day (even up to 5-day) rainfall for various sizes of areas. If there are adequate self-recording stations, the incremental isohyetal maps can be prepared for the selected (or standard) durations of storms, *i.e.*, 6, 12, 18, 24, 30, 42, 48 hours etc.

Step-by-step procedure for drawing DAD curves:

(i) Determine the day of greatest average rainfall, consecutive two days of greatest average rainfall, and like that, up to consecutive five days.

(ii) Plot a map of maximum 1-day rainfall and construct isohyets; similarly prepare isohyetal maps for each of 2, 3, 4 and 5-day rainfall separately.

(iii) The isohyetal map, say, for maximum 1-day rainfall, is divided into zones to represent the principal storm (rainfall) centres.

(iv) Starting with the storm centre in each zone, the area enclosed by each isohyet is planimetered.

(v) The area between the two isohyets multiplied by the average of the two isohyetal values gives the incremental volume of rainfall.

(vi) The incremental volume added with the previous accumulated volume gives the total volume of rainfall.

(vii) The total volume of rainfall divided by the total area upto the encompassing isohyet gives the average depth of rainfall over that area.

(viii) The computations are made for each zone and the zonal values are then combined for areas enclosed by the common (or extending) isohyets.

(ix) The highest average depths for various areas are plotted and a smooth curve is drawn. This is DAD curve for maximum 1-day rainfall.

(x) Similarly, DAD curves for other standard durations (of maximum 2, 3, 4 day etc. or 6, 12, 18, 24 hours etc.) of rainfall are prepared.

Example 2.5 An isohyetal pattern of critical consecutive 4-day storm is shown in Fig. 2.13. Prepare the DAD curve.

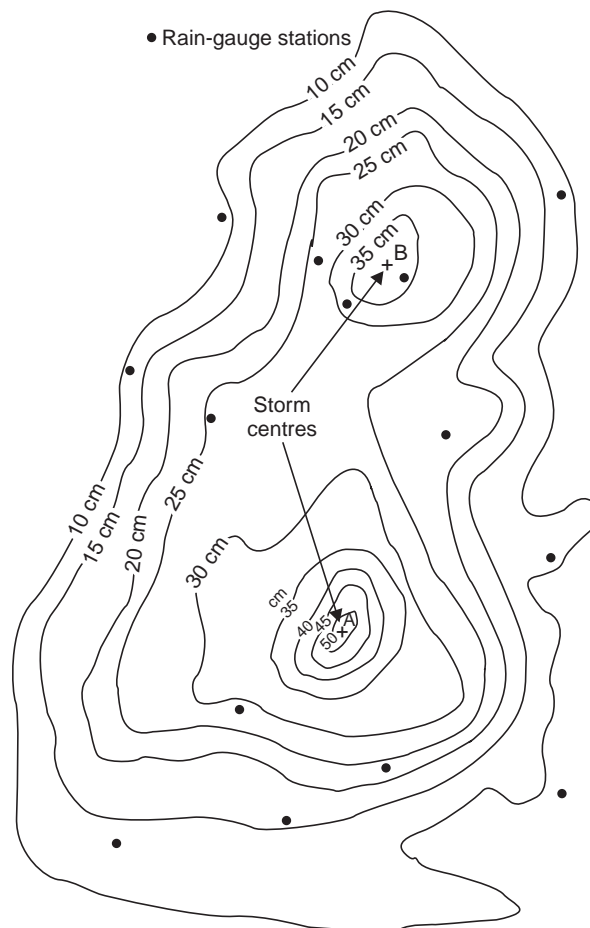

Fig. 2.13 Isohyetal pattern of a 4-day storm, Example 2.5

Solution Computations to draw the DAD curves for a 4-day storm are made in Table 2.1.

Table 2.1. Computation of DAD curve (4-day critical storm)

| <i>Storm centre</i> | <i>Encom passing isohyet (cm)</i> | <i>Area enclosed (km²) (1000)</i> | <i>Isohyetal range (cm)</i> | <i>Average isohyetal value (cm)</i> | <i>Area between isohyets (km²) (1000)</i> | <i>Incremental volume (cm.km²) (1000)</i> | <i>Total volume (cm.km²) (1000)</i> | <i>Average depth (8) ÷ (3) (cm)</i> |
|---------------------|-----------------------------------|--|-----------------------------|-------------------------------------|--|--|--|-------------------------------------|
| 1 | 2 | 3 | 4 | 5 | 6 | 7 | 8 | 9 |
| A | 50 | 0.5 | > 50 | say, 55 | 0.5 | 27.5 | 27.5 | 55 |
| | 40 | 4 | 40–50 | 45 | 3.5 | 157.5 | 185.0 | 46.25 |
| | 35 | 7 | 35–40 | 37.5 | 3 | 112.5 | 297.5 | 42.5 |
| | 30 | 29 | 30–35 | 32.5 | 22 | 715.0 | 1012.5 | 34.91 |
| B | 35 | 2 | > 35 | say, 37.5 | 2 | 75.0 | 75.0 | 37.5 |
| | 30 | 9.5 | 30–35 | 32.5 | 7.5 | 244.0 | 319.0 | 33.6 |
| A | 25 | 82 | 25–30 | 27.5 | 43.5 | 1196.2 | 2527.8 | 30.8 |
| | | 122 | 20–25 | 22.5 | 40 | 900 | 3427.8 | 28.1 |
| | 15 | 156 | 15–20 | 17.5 | 34 | 595 | 4022.8 | 25.8 |
| | | 236 | 10–15 | 12.5 | 80 | 1000 | 5022.8 | 21.3 |

Plot 'col. (9) vs. col. (3)' to get the DAD curve for the maximum 4-day critical storm, as shown in Fig. 2.14.

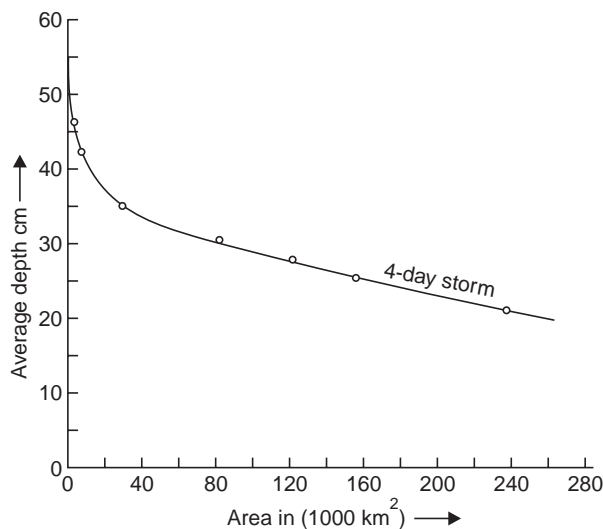

Fig. 2.14 DAD-curve for 4-day storm, Example 2.5

Isohyetal patterns are drawn for the maximum 1-day, 2-day, 3-day and 4-day (consecutive) critical rainstorms that occurred during 13 to 16th July 1944 in the Narmada and Tapti catchments and the DAD curves are prepared as shown in Fig. 2.15. The characteristics of heavy rainstorms that have occurred during the period 1930–68 in the Narmada and Tapti basins are given below:

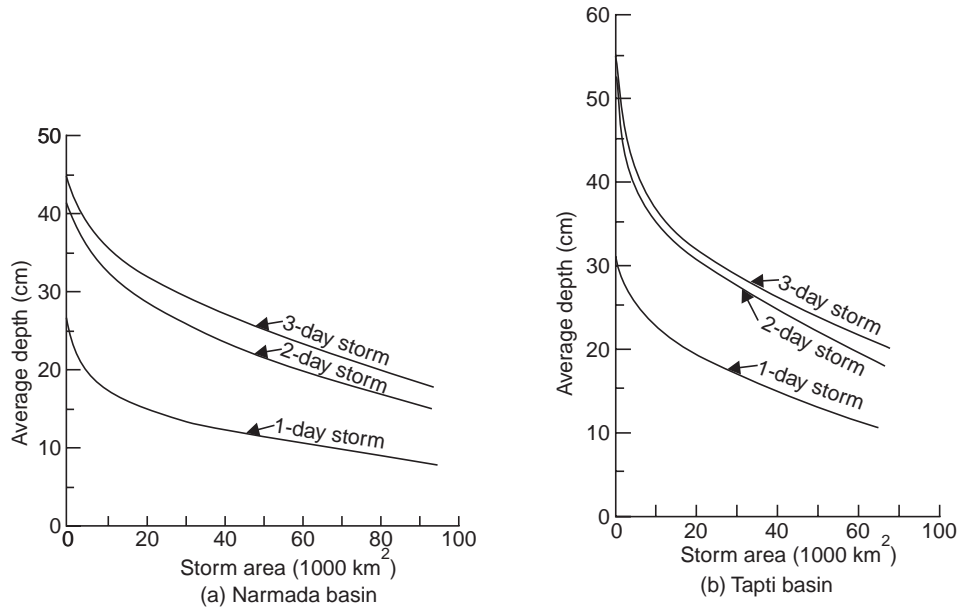

Fig. 2.15 DAD-curves for Narmada & Tapti Basin for rainstorm of 4-6 August 1968

| Year | River basin | Maximum depth of rainfall (cm) | | | |
|----------------|-------------|--------------------------------|-------|-------|-------|
| | | 1-day | 2-day | 3-day | 4-day |
| 13-16 | Narmada | 8.3 | 14.6 | 18.8 | 22.9 |
| July 1944 | Tapti | 6.3 | 9.9 | 11.2 | 15.2 |
| 4-6 | Narmada | 7.6 | 14.5 | 17.4 | |
| August 1968 | Tapti | 11.1 | 19.0 | 21.1 | |
| 8-9 | Narmada | 8.8 | 11.9 | | |
| September 1961 | Tapti | 4.7 | 7.5 | | |
| 21-24 | Narmada | 4.1 | 7.4 | 10.4 | 12.9 |
| September 1945 | Tapti | 10.9 | 14.7 | 18.0 | 20.0 |
| 17 | Narmada | 3.8 | | | |
| August 1944 | Tapti | 10.4 | | | |

2.9 GRAPHICAL REPRESENTATION OF RAINFALL

The variation of rainfall with respect to time may be shown graphically by (i) a hyetograph, and (ii) a mass curve.

A hyetograph is a bar graph showing the intensity of rainfall with respect to time (Fig. 2.16) and is useful in determining the maximum intensities of rainfall during a particular storm as is required in land drainage and design of culverts.

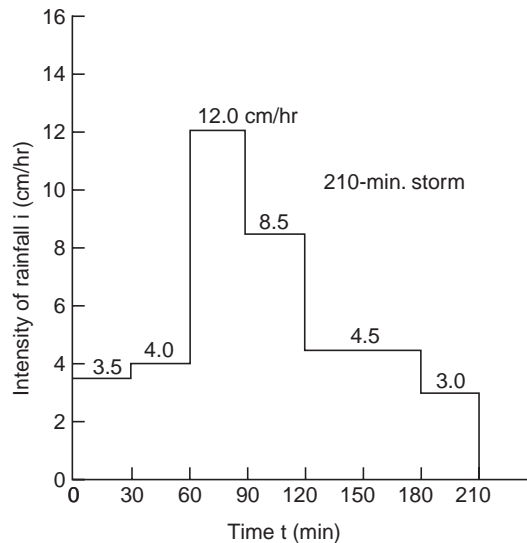

Fig. 2.16 Hyetograph

A mass curve of rainfall (or precipitation) is a plot of cumulative depth of rainfall against time (Fig. 2.17). From the mass curve, the total depth of rainfall and intensity of rainfall at any instant of time can be found. The amount of rainfall for any increment of time is the difference between the ordinates at the beginning and end of the time increments, and the intensity of rainfall at any time is the slope of the mass curve (*i.e.*, $i = \Delta P / \Delta t$) at that time. A mass curve of rainfall is always a rising curve and may have some horizontal sections which indicates periods of no rainfall. The mass curve for the design storm is generally obtained by maximising the mass curves of the severe storms in the basin.

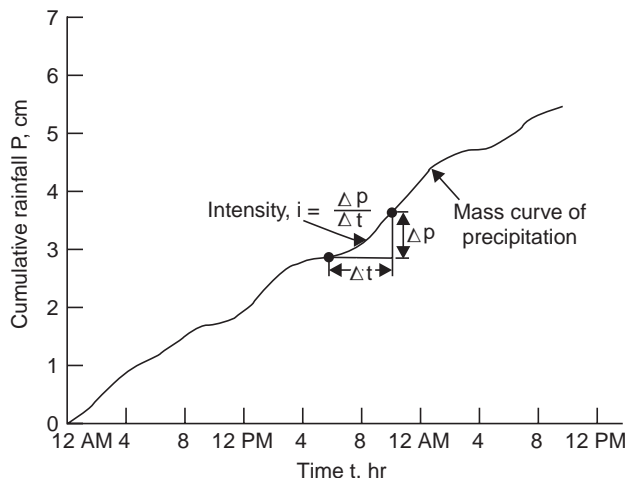

Fig. 2.17 Mass curve of rainfall

2.10 ANALYSIS OF RAINFALL DATA

Rainfall during a year or season (or a number of years) consists of several storms. The characteristics of a rainstorm are (i) intensity (cm/hr), (ii) duration (min, hr, or days), (iii) frequency (once in 5 years or once in 10, 20, 40, 60 or 100 years), and (iv) areal extent (*i.e.*, area over which it is distributed).

Correlation of rainfall records—Suppose a number of years of rainfall records observed on recording and non-recording rain-gauges for a river basin are available; then it is possible to correlate (i) the intensity and duration of storms, and (ii) the intensity, duration and frequency of storms.

If there are storms of different intensities and of various durations, then a relation may be obtained by plotting the intensities (i , cm/hr) against durations (t , min, or hr) of the respective storms either on the natural graph paper, or on a double log (log-log) paper, Fig. 2.18(a) and relations of the form given below may be obtained

$$(a) \quad i = \frac{a}{t+b} \quad \text{A.N. Talbot's formula} \quad \dots(2.5)$$

(for $t = 5\text{-}120$ min)

$$(b) \quad i = \frac{k}{t^n} \quad \dots(2.6)$$

$$(c) \quad i = kt^x \quad \dots(2.7)$$

where t = duration of rainfall or its part, a , b , k , n and x are constants for a given region. Since x is usually negative Eqs. (2.6) and (2.7) are same and are applicable for durations $t > 2$ hr. By taking logarithms on both sides of Eq. (2.7),

$$\log i = \log k + x \log t$$

which is in the form of a straight line, *i.e.*, if i and t are plotted on a log-log paper, the slope of the straight line plot gives the constant x and the constant k can be determined as $i = k$ when $t = 1$. Hence, the fitting equation for the rainfall data of the form of Eq. (2.7) can be determined and similarly of the form of Eqs. (2.5) and (2.6).

On the other hand, if there are rainfall records for 30 to 40 years, the various storms during the period of record may be arranged in the descending order of their magnitude (of maximum depth or intensity). When arranged like this in the descending order, if there are a total number of n items and the order number or rank of any particular storm (maximum depth or intensity) is m , then the recurrence interval T (also known as the return period) of the storm magnitude is given by one of the following equations:

$$(a) \text{ California method (1923), } T = \frac{n}{m} \quad \dots(2.8)$$

$$(b) \text{ Hazen's method (1930), } T = \frac{n}{m - \frac{1}{2}} \quad \dots(2.9)$$

$$(c) \text{ Kimball's method, (Weibull, 1939) } T = \frac{n+1}{m} \quad \dots(2.10)$$

and the frequency F (expressed as per cent of time) of that storm magnitude (having recurrence interval T) is given by

$$F = \frac{1}{T} \times 100\% \quad \dots(2.11)$$

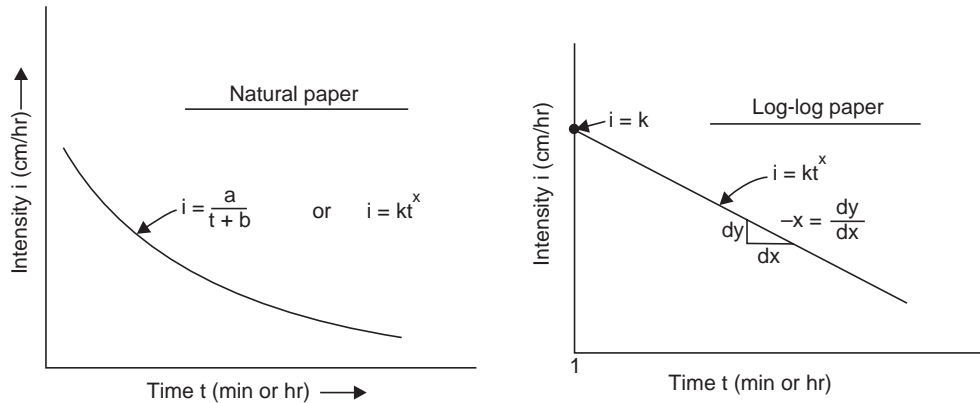

(a) Correlation of intensity and duration of storms

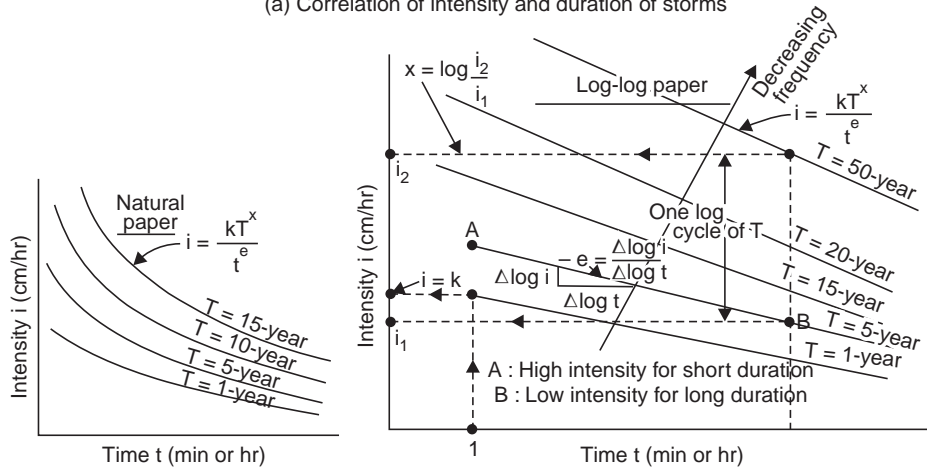

(b) Correlation of intensity, duration and frequency of storms

Fig. 2.18 Correlation of storm characteristics

Values of precipitation plotted against the percentages of time give the ‘frequency curve’. All the three methods given above give very close results especially in the central part of the curve and particularly if the number of items is large.

Recurrence interval is the average number of years during which a storm of given magnitude (maximum depth or intensity) may be expected to occur once, *i.e.*, may be equalled or exceeded. Frequency F is the percentage of years during which a storm of given magnitude may be equalled or exceeded. For example if a storm of a given magnitude is expected to occur once in 20 years, then its recurrence interval $T = 20$ yr, and its frequency (probability of exceedence) $F = (1/20) 100 = 5\%$, *i.e.*, frequency is the reciprocal (percent) of the recurrence interval.

The probability that a T -year storm (and frequency $F = \frac{1}{T} \times 100\%$) may not occur in any series of N years is

$$P_{(N, 0)} = (1 - F)^N \quad \dots(2.12)$$

and that it may occur is

$$P_{Ex} = 1 - (1 - F)^N \quad \dots(2.12a)$$

where P_{Ex} = probability of occurrence of a T -year storm in N -years.

The probability of a 20-year storm (*i.e.*, $T = 20$, $F = 5\%$) will not occur in the next 10 years is $(1 - 0.05)^{10} = 0.6$ or 60% and the probability that the storm will occur (*i.e.*, will be equalled or exceeded) in the next 10 years is $1 - 0.6 = 0.4$ or 40% (percent chance).

See art. 8.5 (Encounter Probability), and Ex. 8.6 (a) and (b) (put storm depth instead of flood).

If the intensity-duration curves are plotted for various storms, for different recurrence intervals, then a relation may be obtained of the form

$$i = \frac{kT^x}{t^e} \quad \dots \text{ Sherman} \quad \dots(2.13)$$

where k , x and e are constants.

' i vs. t ' plotted on a natural graph paper for storms of different recurrence intervals yields curves of the form shown in Fig. 2.18 (b), while on a log-log paper yields straight line plots. By taking logarithms on both sides of Eq. (2.13),

$$\log i = (\log k + x \log T) - e \log t$$

which plots a straight line; $k = i$, when T and t are equal to 1. Writing for two values of T (for the same t):

$$\log i_1 = (\log k + x \log T_1) - e \log t$$

$$\log i_2 = (\log k + x \log T_2) - e \log t$$

$$\text{Subtracting,} \quad \log i_1 - \log i_2 = x (\log T_1 - \log T_2)$$

$$\text{or,} \quad x = \frac{\Delta \log i}{\Delta \log T}$$

$\therefore x$ = charge in log i per log-cycle of T (for the same value of t)

Again writing for two values of t (for the same T):

$$\log i_1 = (\log k + x \log T) - e \log t_1$$

$$\log i_2 = (\log k + x \log T) - e \log t_2$$

$$\text{Subtracting} \quad \log i_1 - \log i_2 = -e (\log t_1 - \log t_2)$$

$$\text{or} \quad -e = \frac{\log i}{\log t}$$

$$\text{or} \quad e = -\text{slope} = \frac{\Delta \log i}{\Delta \log t}$$

$\therefore e$ = change in log i per log cycle of t (for the same value of T).

The lines obtained for different frequencies (*i.e.*, T values) may be taken as roughly parallel for a particular basin though there may be variation in the slope ' e '. Suppose, if a 1-year recurrence interval line is required, draw a line parallel to 10-year line, such that the distance between them is the same as that between 5-year and 50-year line; similarly a 100-year line can be drawn parallel to the 10-year line keeping the same distance (*i.e.*, distance per log cycle of T). The value of i where the 1-year line intersects the unit time ordinate (*i.e.*, $t = 1$ min, say) gives the value of k . Thus all the constants of Eq. (2.13) can be determined from the log-log plot of ' i vs. t ' for different values of T , which requires a long record of rainfall data. Such a long record, will not usually be available for the specific design area and hence it

becomes necessary to apply the intensity duration curves of some nearby rain gauge stations and adjust for the local differences in climate due to difference in elevation, etc. Generally, high intensity precipitations can be expected only for short durations, and higher the intensity of storm, the lesser is its frequency.

The highest recorded intensities are of the order of 3.5 cm in a minute, 20 cm in 20 min and highest observed point annual rainfall of 26 m at Cherrapunji in Assam (India). It has been observed that usually greater the intensity of rainfall, shorter the duration for which the rainfall continues. For example, for upper Jhelum canals (India) maximum intensities are 17.8 and 6.3 cm/hr for storms of 15 and 60 min respectively.

Example 2.5 (a) *In a Certain water shed, the rainfall mass curves were available for 30 (n) consecutive years. The most severe storms for each year were picked up and arranged in the descending order (rank m). The mass curve for storms for three years are given below. Establish*

a relation of the form $i = \frac{kT^x}{t^e}$, by plotting on log-log graph paper.

| Time(min) | 5 | 10 | 15 | 30 | 60 | 90 | 120 |
|------------------------|---|----|----|----|----|----|-----|
| Accumulated depth (mm) | | | | | | | |
| for m = 1 | 9 | 12 | 14 | 17 | 22 | 25 | 30 |
| for m = 3 | 7 | 9 | 11 | 14 | 17 | 21 | 23 |
| for m = 10 | 4 | 5 | 6 | 8 | 11 | 13 | 14 |

Solution

| Time t (min) | 5 | 10 | 15 | 30 | 60 | 90 | 120 | T-yr = $\frac{n+1}{m}$ |
|---------------------|----------------------------------|-----------------------------------|----|----|----|------|------|--------------------------------|
| Intensity i (mm/hr) | | | | | | | | |
| for m = 1 | $\frac{9}{5} \times 60$ = 108 | $\frac{12}{10} \times 60$ = 72 | 56 | 34 | 22 | 16.6 | 15 | $\frac{30+1}{1} \approx 30$ yr |
| for m = 3 | $\frac{7}{5} \times 60$ = 84 | $\frac{9}{10} \times 60$ = 54 | 44 | 28 | 14 | 14 | 11.5 | $\frac{30+1}{3} \approx 10$ yr |
| for m = 10 | $\frac{4}{5} \times 60$ = 48 | $\frac{5}{10} \times 60$ = 30 | 24 | 16 | 11 | 8.7 | 7 | $\frac{30+1}{10} \approx 3$ yr |

The intensity-duration curves (lines) are plotted on log-log paper (Fig. 2.18 (c)), which yield straight lines nearby parallel. A straight line for T = 1-yr is drawn parallel to the line T = 10-yr at a distance equal to that between T = 30-yr and T = 3-yr. From the graph at T = 1-yr and t = 1 min, k = 103.

The slope of the lines, say for T = 30-yr is equal to the change in log i per log cycle of t, i.e., for t = 10 min and 100 min, slope = log 68 – log 17 = 1.8325 – 1.2304 = 0.6021 ≈ 0.6 = e.

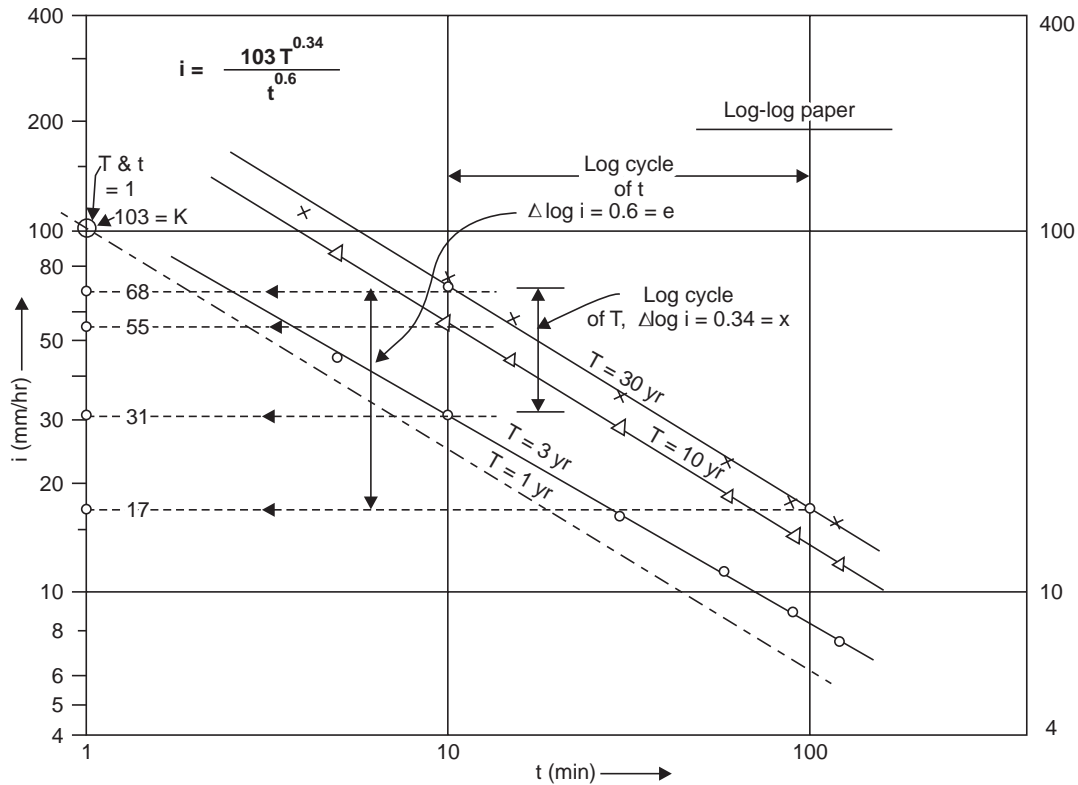

Fig. 2.18. (c) Intensity-duration relationship, (Ex. 2.5 (a))

At $t = 10$ min, the change in $\log i$ per log cycle of T , i.e., between $T = 3$ -yr and 30 -yr lines (on the same vertical), $\log 68 - \log 31 = 1.8325 - 1.4914 = 0.3411 \approx 0.34 = x$.

Hence, the intensity-duration relationship for the watershed can be established as

$$i = \frac{104 T^{0.34}}{t^{0.6}}$$

For illustration, for the most severe storm ($m = 1$, $T = 30$ -yr), at $t = 60$ min, i.e., after 1 hr of commencement of storm,

$$i = \frac{103 (30)^{0.34}}{(60)^{0.6}} = \mathbf{28 \text{ mm/hr}}$$

which is very near to the observed value of 22 mm/hr.

A more general Intensity-Duration-Frequency (IDF) relationship is of the form

$$\text{Sherman} \quad i = \frac{KT^x}{(t+a)^n}, \quad i \text{ in cm/hr, } t \text{ in min, } T \text{ yr.}$$

where K , x , a and n are constants for a given catchment. The rainfall records for about 30 to 50 years of different intensities and durations on a basin can be analysed with their computed recurrence interval (T). They can be plotted giving trial values of 'a' for the lines of best fit as

shown in Fig. 2.18 (b). The values of a and n may be different for different lines of recurrence interval.

The constants can also be obtained by *multiple regression model* based on the principle of least squares and solutions can be obtained by computer-based numerical analysis; confidence intervals for the predictions can be developed.

Extreme point rainfall values of different durations and recurrence interval (return period) have been evaluated by IMD and the 'isopluvial maps' (lines connecting equal depths of rainfall) for the country prepared.

Example 2.5 (b) A small water shed consists of 2 km² of forest area ($c = 0.1$), 1.2 km² of cultivated area ($c = 0.2$) and 1 km² under grass cover ($c = 0.35$). A water course falls by 20 m in a length of 2 km. The IDF relation for the area may be taken as

$$i = \frac{80 T^{0.2}}{(t + 12)^{0.5}}, \quad i \text{ in cm/hr, } t \text{ in min and } T \text{ yr}$$

Estimate the peak rate of runoff for a 25 yr frequency.

Solution Time of concentration (in hr)

$$\begin{aligned} t_c &= 0.06628 L^{0.77} S^{-0.385}, && \text{Kirpich's formula, } L \text{ in km} \\ &= 0.06628 \times 2^{0.77} \left(\frac{20}{2 \times 1000} \right)^{-0.385} && = 0.667 \text{ hr} \times 60 = 40 \text{ min.} \end{aligned}$$

$i = i_c$ when $t = t_c$ in the given *IDF* relation

$$\therefore i_c = \frac{80 \times 25^{0.2}}{(40 + 12)^{0.5}} = 21.1 \text{ cm/hr}$$

$$\begin{aligned} Q_{peak} &= 2.78 C i_c A, && \text{rational formula, } CA = \Sigma C_i A_i \\ &= 2.78 \times 21.1 \times (0.1 \times 2 + 0.2 \times 1.2 + 0.35 \times 1) = \mathbf{46.4 \text{ cumec}} \end{aligned}$$

2.11 MEAN AND MEDIAN

The sum of all the items in a set divided by the number of items gives the mean value, *i.e.*,

$$\bar{x} = \frac{\Sigma x}{n} \quad \dots(2.10)$$

where \bar{x} = the mean value

Σx = sum of all the items

n = total number of items.

The magnitude of the item in a set such that half of the total number of items are larger and half are smaller is called the median. The apparent median for the curve in Fig. 2.21 is the ordinate corresponding to 50% of the years. The mean may be unduly influenced by a few large or small values, which are not truly representative of the samples (items), whereas the median is influenced mainly by the magnitude of the main part of intermediate values.

To find the median, the items are arranged in the ascending order; if the number of items is odd, the middle item gives the median; if the number of items is even, the average of the central two items gives the median.

Example 2.6 The annual rainfall at a place for a period of 10 years from 1961 to 1970 are respectively 30.3, 41.0, 33.5, 34.0, 33.3, 36.2, 33.6, 30.2, 35.5, 36.3. Determine the mean and median values of annual rainfall for the place.

$$\begin{aligned} \text{Solution (i) Mean } \bar{x} &= \frac{\Sigma x}{n} = (30.3 + 41.0 + 33.5 + 34.0 + 33.3 + 36.2 \\ &\quad + 33.6 + 30.2 + 35.5 + 36.3)/10 \\ &= \frac{343.9}{10} = \mathbf{34.39 \text{ cm}} \end{aligned}$$

(ii) Median: Arrange the samples in the ascending order 30.2, 30.3, 33.3, 33.5, 33.6, 34.0, 35.5, 36.2, 36.3, 41.0

No. of items = 10, *i.e.*, even

$$\therefore \text{Median} = \frac{33.6 + 34.0}{2} = \mathbf{33.8 \text{ cm}}$$

Note the difference between the mean and the median values. If 11 years of record, say 1960 to 1970, had been given, the median would have been the sixth item (central value) when arranged in the ascending order.

Example 2.7 The following are the rain gauge observations during a storm. Construct: (a) mass curve of precipitation, (b) hyetograph, (c) maximum intensity-duration curve and develop a formula, and (d) maximum depth-duration curve.

| <i>Time since commencement of storm (min)</i> | <i>Accumulated rainfall (cm)</i> |
|---|--|
| 5 | 0.1 |
| 10 | 0.2 |
| 15 | 0.8 |
| 20 | 1.5 |
| 25 | 1.8 |
| 30 | 2.0 |
| 35 | 2.5 |
| 40 | 2.7 |
| 45 | 2.9 |
| 50 | 3.1 |

Solution (a) Mass curve of precipitation. The plot of 'accumulated rainfall (cm) vs. time (min)' gives the 'mass curve of rainfall' Fig. 2.19 (a).

(b) *Hyetograph.* The intensity of rainfall at successive 5 min interval is calculated and a bar-graph of 'i (cm/hr) vs. t (min)' is constructed; this depicts the variation of the intensity of rainfall with respect to time and is called the 'hyetograph; 2.19 (b).

| <i>Time, t</i> (min) | <i>Accumulated rainfall</i> (cm) | ΔP in time $\Delta t = 5 \text{ min}$ (cm) | <i>Intensity,</i> $i = \frac{\Delta P}{\Delta t} \times 60$ (cm/hr) |
|-------------------------|-------------------------------------|--|---|
| 5 | 0.1 | 0.1 | 1.2 |
| 10 | 0.2 | 0.1 | 1.2 |
| 15 | 0.8 | 0.6 | 7.2 |
| 20 | 1.5 | 0.7 | 8.4 |
| 25 | 1.8 | 0.3 | 3.6 |
| 30 | 2.0 | 0.2 | 2.4 |
| 35 | 2.5 | 0.5 | 6.0 |
| 40 | 2.7 | 0.2 | 2.4 |
| 45 | 2.9 | 0.2 | 2.4 |
| 50 | 3.1 | 0.2 | 2.4 |

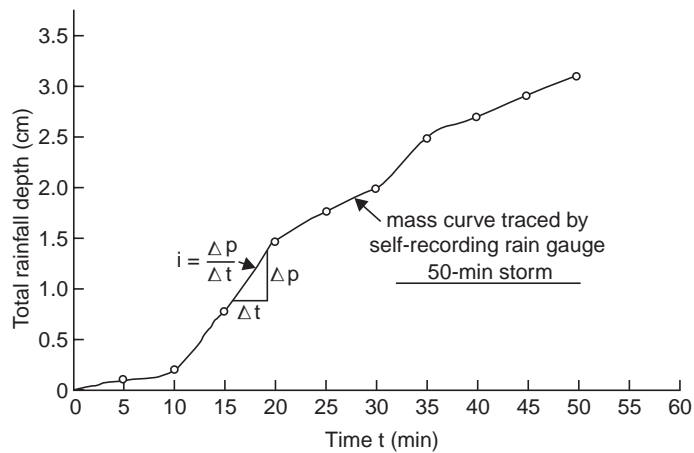

(a) Mass curve of precipitation

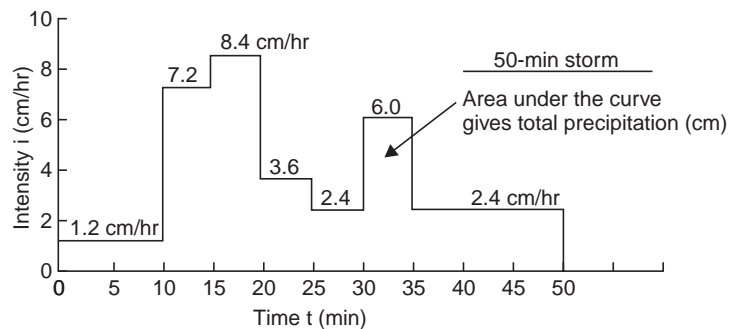

(b) Hyetograph

Fig. 2.19 Graphs from recording rain-gauge data, Example 2.7

(c) *Maximum depth–duration curve.* By inspection of time (t) and accumulated rainfall (cm) the maximum rainfall depths during 5, 10, 15, 20, 25, 30, 35, 40, 45 and 50 min durations

are 0.7, 1.3, 1.6, 1.8, 2.3, 2.5, 2.7, 2.9, 3.0 and 3.1 cm respectively. The plot of the maximum rainfall depths against different durations on a log-log paper gives the maximum depth-duration curve, which is a straight line, Fig. 2.20 (a).

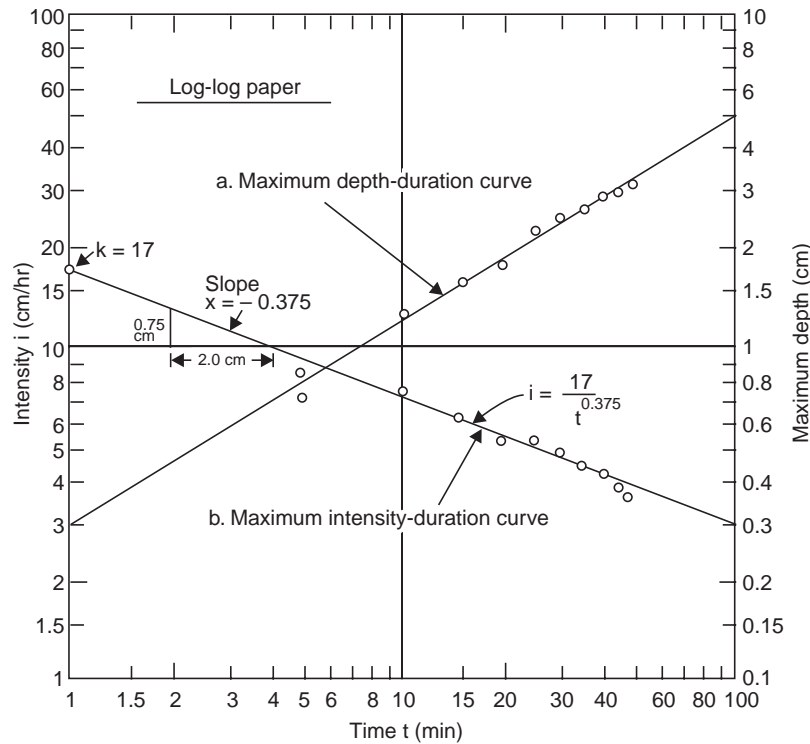

Fig. 2.20 Maximum depth-duration & intensity-duration curves (Example 2.7)

(d) *Maximum intensity-duration curve.* Corresponding to the maximum depths obtained in (c) above, the corresponding maximum intensities can be obtained $\frac{\Delta P}{\Delta t} \times 60$, i.e., 8.4, 7.8, 6.4, 5.4, 5.52, 5.0, 4.63, 4.35, 4.0 and 3.72 cm/hr, respectively. The plot of the maximum intensities against the different duration on a log-log paper gives the maximum intensity-duration curve which is a straight line, Fig. 2.20 (b).

The equation for the maximum intensity duration curve is of the form

$$i = kt^x$$

Slope of the straight line plot,

$$-x = \frac{dy}{dx} = \frac{0.75 \text{ cm}}{2.00 \text{ cm}} = 0.375$$

$$k = 17 \text{ cm/hr} \quad \text{when } t = 1 \text{ min}$$

Hence, the formula becomes

$$i = \frac{17}{t^{0.375}}$$

which can now be verified as

$$t = 10 \text{ min}, i = 7.2 \text{ cm/hr}$$

$$t = 40 \text{ min}, i = 4.25 \text{ cm/hr}$$

which agree with the observed data

Example 2.8 The annual rainfall at a place for a period of 21 years is given below. Draw the rainfall frequency curve and determine :

- the rainfall of 5-year and 20-year recurrence, interval
- the rainfall which occurs 50% of the times
- the rainfall of probability of 0.75
- the probability of occurrence of rainfall of 75 cm and its recurrence interval.

| Year | Rainfall (cm) | Year | Rainfall (cm) |
|------|------------------|------|------------------|
| 1950 | 50 | 1961 | 56 |
| 1951 | 60 | 1962 | 52 |
| 1952 | 40 | 1963 | 42 |
| 1953 | 27 | 1964 | 38 |
| 1954 | 30 | 1965 | 27 |
| 1955 | 38 | 1966 | 40 |
| 1956 | 70 | 1967 | 100 |
| 1957 | 60 | 1968 | 90 |
| 1958 | 35 | 1969 | 44 |
| 1959 | 55 | 1970 | 33 |
| 1960 | 40 | | |

Solution Arrange the yearly rainfall in the descending order of magnitude as given below. If a particular rainfall occurs in more than one year, m = no. of times exceeded + no. of times equalled.

| Year | Rainfall P (cm) | Rank (m) (no. of times $\geq P$) | Frequency $F = \frac{m}{n+1} \times 100\%$ |
|-------------------------|----------------------|--|---|
| 1967 | 100 | 1 | 4.6 |
| 1968 | 90 | 2 | 9.1 |
| 1956 | 70 | 3 | 13.6 |
| 1951, 1957 | 60 | 5 | 22.7 |
| 1961 | 56 | 6 | 27.3 |
| 1959 | 55 | 7 | 31.8 |
| 1962 | 52 | 8 | 36.4 |
| 1950 | 50 | 9 | 40.9 |
| 1969 | 43 | 10 | 45.5 |
| 1963 | 42 | 11 | 50.0 |
| 1952, 1960 } 1966 } | 40 | 14 | 63.7 |
| 1955, 1964 | 38 | 16 | 72.8 |
| 1958 | 35 | 17 | 77.3 |
| 1970 | 33 | 18 | 81.8 |
| 1954 | 30 | 19 | 86.4 |
| 1953, 1965 | 27 | 21 | 95.5 |
| Total $\Sigma x = 1026$ | | $n = 21$ | |

Draw the graph of ' P vs. F ' on a semi-log paper which gives the rainfall frequency curve, Fig. 2.21. From the frequency-curve, the required values can be obtained as

$$(a) \quad T = 5\text{-yr}, F = \frac{1}{T} \times 100 = \frac{100}{5} = 20\% \text{ for which } P = 64 \text{ cm.}$$

$$T = 20\text{-yr}, F = \frac{1}{20} \times 100 = 5\% \text{ for which } P = 97.5 \text{ cm}$$

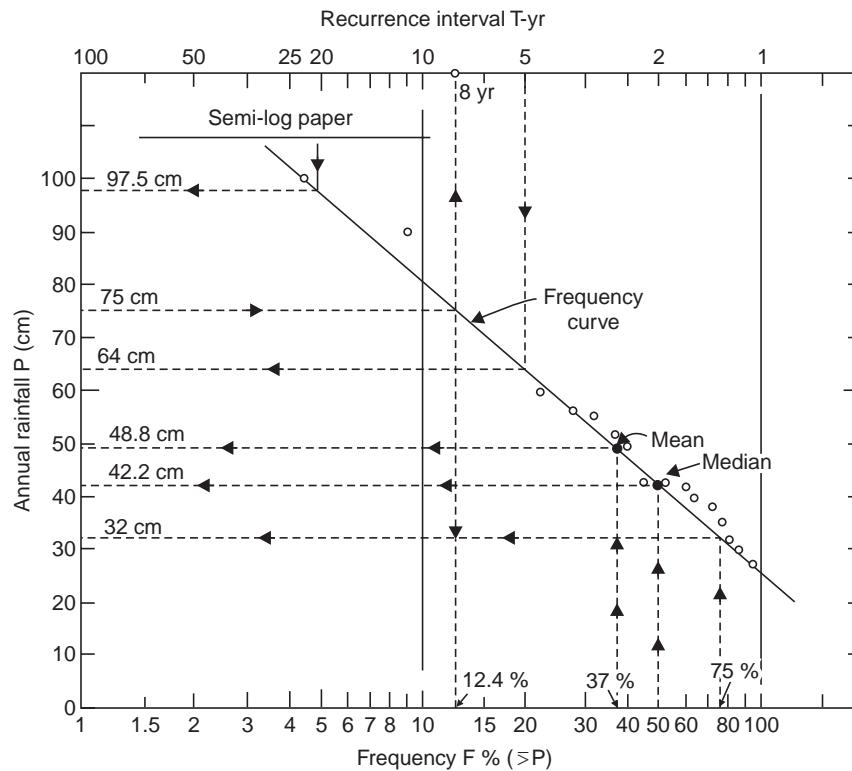

Fig. 2.21 Rainfall frequency curve (Example 2.8)

(b) For $F = 50\%$, $P = 42.2 \text{ cm}$ which is the median value, and the mean value

$$\bar{x} = \frac{\Sigma x}{n} = \frac{1026}{21} = 48.8 \text{ cm}$$

which has a frequency of 37%.

(c) For a probability of 0.75 $F = 75\%$ for which $P = 32 \text{ cm}$

$$(d) \text{ For } P = 75 \text{ cm}, F = 12.4\%, T = \frac{1}{F} \times 100 = \frac{100}{12.4} = 8 \text{ yr}$$

and its probability of occurrence = **0.124**

2.12 MOVING AVERAGES CURVE

If the rainfall at a place over a number of years is plotted as a bar graph it will not show any trends or cyclic patterns in the rainfall due to wide variations in the consecutive years. In

order to depict a general trend in the rainfall pattern, the averages of three or five consecutive years are found out progressively by moving the group averaged, one year at a time. In Fig. 2.22, the 21-years of rainfall records at a place given in Example 2.8 are shown. The first five years of record are averaged as $(50 + 60 + 40 + 27 + 30)/5 = 207/5 = 41.4$ cm and this average is plotted at the mid-point of the group. The next point is obtained by omitting the first and averaging the 2 to 6 years of record, again plotting the average *i.e.*, $(207 - 50 + 38)/5 = 39$ cm at the midpoint of this group, and so on as shown in Fig. 2.22. Thus, a 5-year moving mean curve is obtained in which the wide variations in the consecutive years are smoothed out. A 3-year or 5-year moving mean curve is useful in identifying the long term trends or patterns in the rainfall at a place.

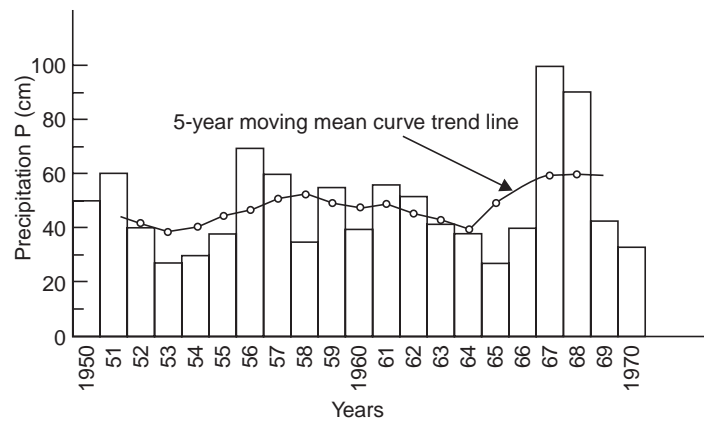

Fig. 2.22 Trends from moving mean curves (Example 2.8)

The same techniques may be applied to other hydrometeorological parameters like temperature, hours of bright sunshine, wind speeds, cloud cover, etc.

2.13 DESIGN STORM AND PMP

For the safe design of structures even a 50-year or 100-year precipitation may be inadequate due to the unusual meteorological combinations resulting in very high precipitation. The most critical features of several past storms are often combined, for a given frequency of occurrence, into a single design storm (hypothetical) for the purpose of design of important structures. The probable maximum precipitation (PMP) for a given region is the precipitation resulting from the most critical meteorological combinations that are considered probable of occurrence. This concept of PMP is very important in estimating the maximum probable flood in the safe design of flood control structures, spillways for dams, etc. PMP can be estimated by maximising the different parameters like wind velocity, humidity etc. of an observed severe storm over the basin. When sufficient data of storms for a given basin is not available, PMP can be estimated from a severe storm on the adjacent basin and storm transposition.

2.14 SNOW PACK AND SNOW MELT

Snow melts due to heat from the atmosphere, from the warm rainfall and by radiation. On the basis of measurement of snow depth and water equivalent (or density) of snow at grid stations

along the snow courses, the water storage in the snow (*i.e.*, the available snow melt) can be determined from the formula.

$$d_w = G_s d_s \quad \dots(2.11)$$

where d_w = depth of water storage in the snow

d_s = depth of snow cover

G_s = water equivalent (density) of snow

Water equivalent or snow density is the ratio of the volume of melt water from a sample of snow to the initial volume of the snow sample. An average density of 0.1 for freshly fallen snow is often assumed; however the longer the snow remains on the ground, the denser it becomes due to packing, alternate thawing and freezing, condensation and the presence of absorbed rainfall and melt water. Snow density will be about 0.1 at the beginning of winter and about 0.3 at the end of winter, *i.e.*, at the beginning of thaw. The density of snow varies with depth and so samples must be taken at various horizons in a snow pack for determining the water equivalent. This is usually done by a sampling tube. Snowfall may be measured directly by an ordinary rain gauge fitted with a heating system, or by a simple snow stake, if there is no drifting and density is determined simultaneously.

Snow surveys are made by dividing the basin into rectangular grids and determining the snow depths and densities at depths at the grid stations. From the water equivalents thus obtained at individual stations, the average water equivalent of the snow pack over the entire basin can be derived by the same method used for determining the mean areal depth of rainfall. In India, snow surveys are generally conducted in the beginning of summer, *i.e.*, in March or April, when snow starts melting. Many of the perennial rivers in north India are fed by snow-melt from the Himalayan range in summer. In the Himalayan range, one-tenth of the depth of snow is added to the depth of rainfall, as a thumb rule, to obtain the total precipitation.

Also see Appendix-A.

QUIZ II

I Match the items in 'A' with items in 'B':

A

- (i) Cyclone
- (ii) Frontal surface
- (iii) Rain-gauge
- (iv) Double mass curve
- (v) Tipping bucket gauge
- (vi) Recording rain-gauge
- (vii) Orographic precipitation
- (viii) Thiessen network
- (ix) Raingauge density
- (x) Coefficient of variation, C_v

B

- (a) Optimum rain-gauge network
- (b) Intensity of storm
- (c) Can not record snow
- (d) 1 in 500 km²
- (e) Mean areal depth of precipitation
- (f) Western Ghats (of Peninsular India)
- (g) Covergence of storm
- (h) Surface of contact between warm and cold air masses
- (i) Air port
- (j) Change of regime of rain-gauge station

II Fill up the blanks in the following:

- (i) Rain-gauges are erected..... over the ground surface with their rim at cm above ground surface
- (ii) The three principal agencies, which maintain rain-gauges and make observations in Karnataka are: (a) (b) and (c)
- (iii) Rain-gauge readings are taken every day at hr IST
- (iv) In coastal areas of Karnataka one rain-gauge should be erected for every km² and years (consecutive) of record are required for statistical analysis.
- (v) An index of wetness of 40% in a certain area indicates a year with a rainfall deficiency of%.

III Say 'True' or 'False'; if false, give the correct statement:

- (i) Rain-gauges are erected perpendicular to the ground surface on which they are installed.
- (ii) Cyclonic precipitation is due to convergence of storms towards a low pressure belt.
- (iii) In hilly and heavy rainfall areas at least 10% of the rain-gauges should be of self-recording type.
- (iv) As the area increases, the average depth of precipitation increases for a particular storm.
- (v) Generally, high intensity precipitation can be expected only for short durations, and higher the intensity, lesser is its frequency.
- (vi) The coefficient of variation for annual precipitation data is equal to the standard deviation of the indices of wetness.
- (vii) A mass curve of rainfall need not always be a rising curve.
- (viii) The longer the snow remains on the ground, the less dense it becomes.
- (ix) The intensity of storm is an inverse function of its duration. (false: *i, iv, vii, viii*)

IV Choose the correct statement/s in the following:**1** Precipitation includes

- (i) rainfall
- (ii) snow melt
- (iii) hail storm
- (iv) stream flow
- (v) mist and fog
- (vi) frost
- (vii) all the above

2 In a cold front

- (i) cold air mass drives out a warm air mass
- (ii) warm air mass replaces the retreating cold air mass
- (iii) cold air and warm air masses are drawn simultaneously towards a low pressure area
- (iv) the cold and warm air masses are stationary

3 Cyclonic precipitation is due to

- (i) orographic lifting
- (ii) ocean nearby
- (iii) convergence of storms towards a low pressure belt
- (iv) divergence of storms
- (v) thermal convection
- (vi) conflict between cold and warm air masses

4 A self-recording rain-gauge

- (i) records by hourly depth of rain
- (ii) records the snow melt
- (iii) records the cumulative depth of rainfall
- (iv) records the rainfall intensity
- (v) records the onset and cessation of rainfall
- (vi) records the cloud cover

- 5** A double mass analysis is made
- (i) to find the missing rainfall at a station in a particular area
 - (ii) to detect any change in exposure of a station
 - (iii) to adjust the record at a station to the changed environment
 - (iv) to compute the a.a.r. consistent with the changed environment
 - (v) for all the above purposes
- 6** Isohyetal method gives accurate mean areal depth of rainfall
- (i) in a plain country
 - (ii) in a gently sloping basin
 - (iii) in an undulating country
 - (iv) in places of known storm movement
 - (v) in a basin consisting of plains and hills
 - (vi) when there are optimum number of rain-gauge stations
 - (vii) when the precipitation includes snowmelt
- (1-except iv; 2-*i* ; 3-*iii* ; 4-*iii, v* ; 5-*ii, iii, iv* ; 6-*iii, iv, v*)

QUESTIONS

- 1** What factors you consider in selecting a site for a rain-gauge station?
- 2** (a) Distinguish between recording and non-recording rain-gauges, giving examples of such gauges used in India.
- (b) Which are the agencies that usually maintain rain-gauges and make observations in your State? At what time or times in the day is the rainfall recorded?
- 3** What are the different forms of precipitation ? Which of them are of significance to a civil engineer ?
- 4** (a) Explain: (i) a method for estimating the missing rainfall data at a station in a basin.
- (ii) a method for testing the consistency of rainfall records at a station and necessary adjustment.
- (b) A 3-hour storm occurred at a place and the precipitations in the neighbouring rain-gauge stations *P*, *Q* and *R* were measured as 3.8, 4.1 and 4.5 cm, respectively. The precipitation in the neighbouring station *S* could not be measured since the rain-gauge bottle was broken. The normal precipitation in the four stations *P*, *Q*, *R* and *S* as per IMD Bulletin were 45, 48, 53 and 50 cm, respectively. Estimate the storm precipitation at station *S*. (4.246 cm)
- 5** (a) Define 'rain-gauge density' and explain how you would determine the optimum number of rain-gauges to be erected in a given basin.
- (b) In a certain river basin there are six rain-gauge stations, the normal annual rainfall depths at the stations being 42.4, 53.6, 67.8, 78.5, 82.7 and 95.5 cm, respectively. Determine the optimum number of rain-gauge stations to be established in the basin if it is desired to limit the error in the mean value of rainfall over the catchment to 10% and indicate how you distribute them, (7)
- 6** For the basin shown in Fig. P 2.23, the normal annual rainfall depths recorded and the isohyets are given. Determine the optimum number of rain-gauge stations to be established in the basin if it is desired to limit the error in the mean value of rainfall to 10%. Indicate how you are going to distribute the additional rain-gauge stations required if any. What is the percentage accuracy

of the existing network in the estimation of the average depth of rainfall over the basin. The area between the isohyets are given below :

| Zone: | I | II | III | IV | V | VI | Total |
|--------------------------|----|-----|-----|-----|----|----|-------|
| Area (Km ²): | 63 | 278 | 389 | 220 | 55 | 33 | 1038 |

(16—1, 1, 4, 2, 0, 1; 85.2%)

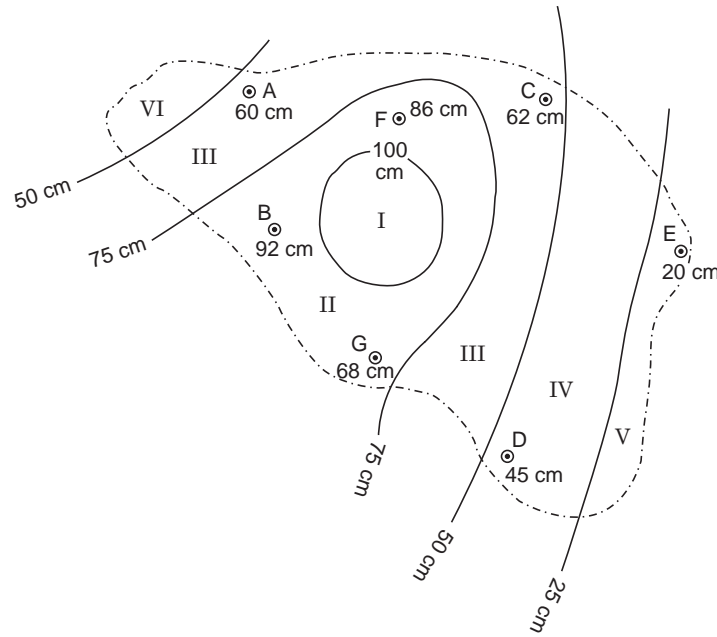

Fig. P2.23 Isohyetal map

- 7 (a) Explain three methods of determining the mean areal depth of precipitation over a basin covered by several rain-gauge stations.
- (b) Find the mean precipitation for the area shown in Fig. P 2.24 by Thiessen polygon method. The area is composed of a square plus an equilateral triangular plot of side 2 km. Rainfall readings are in cm at the various stations indicated. (32.33 cm)

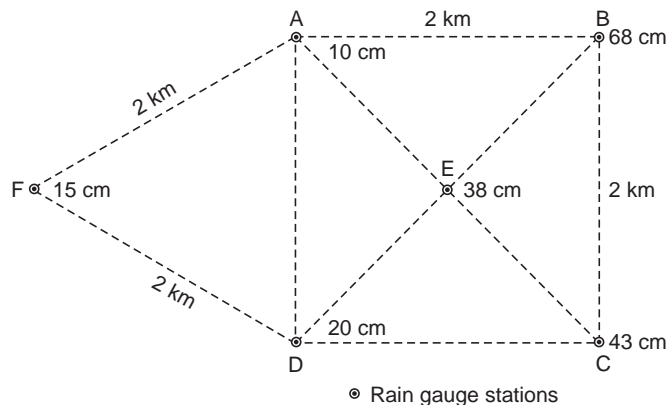

Fig. P2.24 Rain-gauge network

- 8 Thiessen polygons and isohyetal map are given in Fig. P 2.25 and P 2.26, respectively, for different drainage basins. Areas and precipitation values are tabulated. Compute the average precipitation over the basins.

| <i>Station</i> | <i>Thiessen polygon area (km²)</i> | <i>Precipitation (cm)</i> |
|----------------|---|---------------------------|
| A | 170 | 9.3 |
| B | 164 | 10.5 |
| C | 156 | 10.9 |
| D | 150 | 12.2 |
| E | 116 | 13.5 |
| F | 36 | 14.0 |
| G | 124 | 14.2 |
| H | 42 | 12.8 |
| Area of basin | | = 958 km ² |

| <i>Zone</i> | <i>Area (km²)</i> | |
|---------------|------------------------------|------------------------|
| I | 56 | |
| II | 192 | |
| III | 420 | |
| IV | 244 | |
| V | 44 | |
| VI | 58 | |
| Area of basin | | = 1014 km ² |

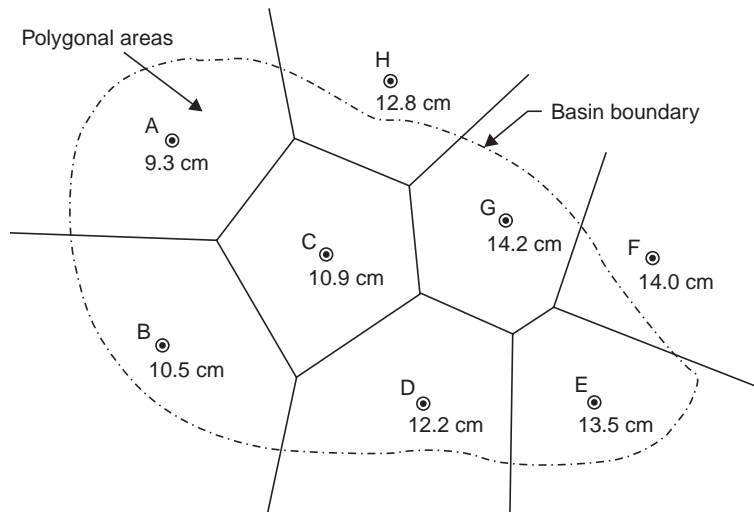

Fig. P2.25 Thiessen polygons

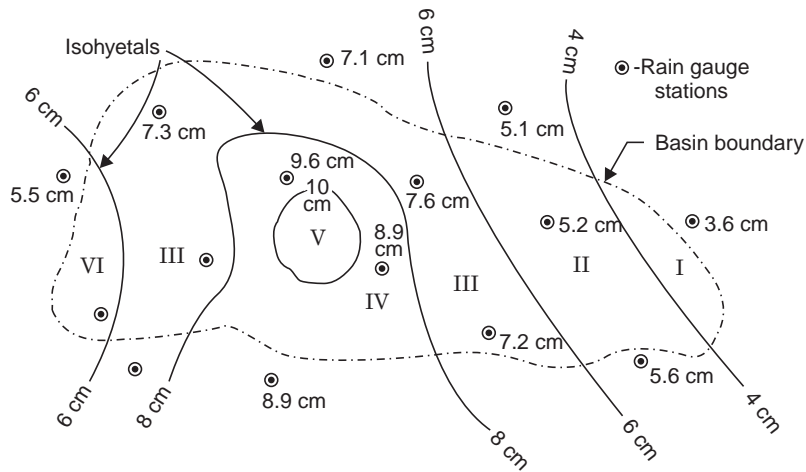

Fig. P2.26 Isohyetal map

- 9 About 20 years of rainfall records (from both recording and non-recording rain-gauge stations) are available. Exemplify with neat diagrams, giving typical formulae, how you correlate
- (i) intensity and duration of storms
 - (ii) intensity, duration and frequency of stoms
- 10 The annual rainfall at a place for a period of 30 years is given below. Draw the rainfall frequency curve and determine
- (a) rainfalls of 5-yr, 10-yr and 20-yr recurrence interval
 - (b) the rainfall of probability 0.75
 - (c) the probability of occurence of rainfall ≥ 35 cm

| Year | Rainfall (cm) | Year | Rainfall (cm) |
|------|---------------|------|---------------|
| 1951 | 31.6 | 1966 | 36.2 |
| 1952 | 30.1 | 1967 | 33.6 |
| 1953 | 29.8 | 1968 | 30.2 |
| 1954 | 39.9 | 1969 | 35.5 |
| 1955 | 37.8 | 1970 | 36.3 |
| 1956 | 31.3 | 1971 | 36.4 |
| 1957 | 30.7 | 1972 | 30.7 |
| 1958 | 38.0 | 1973 | 33.4 |
| 1959 | 35.7 | 1974 | 40.4 |
| 1960 | 32.9 | 1975 | 35.4 |
| 1961 | 30.3 | 1976 | 33.7 |
| 1962 | 41.0 | 1977 | 30.1 |
| 1963 | 33.5 | 1978 | 31.7 |
| 1964 | 34.0 | 1979 | 33.4 |
| 1965 | 33.3 | 1980 | 30.2 |

11. The values of annual precipitation (cm/year) at a rain-gauge station in chronological sequence from 1966 to 1977 are given below : Estimate the maximum and minimum values of precipitation which has a recurrence interval of 5 years.

| | | | | | |
|------|------|------|------|------|------|
| 36.5 | 29.0 | 56.2 | 82.0 | 27.8 | 23.4 |
| 71.2 | 48.3 | 31.4 | 18.1 | 29.0 | 65.6 |

Hint for P_{max} arrange P 's in the descending order when m is the no. of times P is equalled or exceeded; for P_{min} arrange P 's in the ascending order when m is the no. of times equal to or less than P ; use any of the three methods; from the graph, find $P_{max \text{ or } min}$ for $T_r = 5\text{-yr}$.

12. Annual precipitation at rain-gauge station X and the average annual precipitation at 20 surrounding rain-gauge stations are given below. Examine the consistency of data at station X . Indicate at what year a change in regime has occurred and how you are going to make the necessary adjustments.

| Year | Annual rainfall at stn. X (cm) | Ave. ann. rainfall of 20 stns. (cm) | Year | Annual rainfall at stn. X (cm) | Ave. ann. rainfall of 20 stns. (cm) |
|------|----------------------------------|-------------------------------------|------|----------------------------------|-------------------------------------|
| 1962 | 30.5 | 22.8 | 1972 | 28.2 | 33.3 |
| 1963 | 38.9 | 35.0 | 1973 | 17.3 | 23.4 |
| 1964 | 43.7 | 30.2 | 1974 | 22.3 | 36.0 |
| 1965 | 32.2 | 27.4 | 1975 | 28.4 | 31.2 |
| 1966 | 27.4 | 25.2 | 1976 | 24.1 | 23.1 |
| 1967 | 32.0 | 28.2 | 1977 | 26.9 | 23.4 |
| 1968 | 49.3 | 36.1 | 1978 | 20.6 | 23.1 |
| 1969 | 28.4 | 28.4 | 1979 | 29.5 | 33.2 |
| 1970 | 24.6 | 25.1 | 1980 | 28.4 | 26.4 |
| 1971 | 21.8 | 23.6 | | | |

13. Define 'water equivalent of snow' and explain how you estimate the snow melt?
14. Discuss the analysis of rainfall data with respect to time, space, frequency and intensity.
15. Explain areal and temporal distribution pattern of a typical storm over a catchment.
16. What is rain-gauge density? How does it affect the accuracy of rainfall measurements?
17. (a) What is meant by 'frequency of rainfall' and 'recurrence interval'?
- (b) A rainfall of certain high intensity is expected to occur once in 20 years. What is its chance of occurrence in any year? What is the probability that it may occur in the next 12 years, and it may not occur in the next 8 years. (5%, 46%, 66.4%)
18. Distinguish between snow, hail and rain. Explain the melting process of snow and the method of measuring snow fall depth.
19. Estimate the intensity of a storm; which lasted for 60 min; constants in Talbot's formula: $a = 260$, $b = 15$, apply. (3.47 cm/hr)
20. The following are the modified data for a typical design storm of the Tapti river Basin in western India. Develop a formula for the intensity duration relationship.

| | | | | | | | |
|----------------------------|----|----|----|----|-----|-----|-----|
| Time (hr): | 1 | 2 | 3 | 6 | 12 | 24 | 48 |
| Accumulated rainfall (mm): | 25 | 42 | 58 | 92 | 143 | 221 | 341 |

$$\left[i = \frac{25}{t^{0.4}} \text{ mm/hr} \right]$$

- 21 Using rational method, rainfall intensity-duration curves and the data given in Fig. P 2.27 compute the diameter of the outfall sewer. The length of lines, drainage areas, and inlet times are marked in Fig. P 2.27 (a). Assume:
- (i) Run-off coefficient for the entire area = 0.30
 - (ii) Velocity of flow in sewers flowing full = 0.75 m/sec
 - (iii) 5-year average frequency curve may be used, Fig. P 2.27 (b),
 - (iv) Hydraulic elements for circular pipes flowing full are given in Table 2.2.

Table 2.2 Hydraulic elements for a circular pipe flowing full

| Discharge (Ips) | Diameter (mm) | Slope of Pipe (m/m) | Velocity (m/sec) |
|--------------------|------------------|------------------------|---------------------|
| 400 | 450 | 0.025 | 2.7 |
| 600 | 525 | 0.020 | 2.8 |
| 690 | 1050 | 0.00055 | 0.75 |
| 1500 | 1350 | 0.001 | 1.55 |
| 2000 | 1450 | 0.001 | 1.20 |

[690 lps, 0.75 m/s, 1 m laid at 1 in 1800]

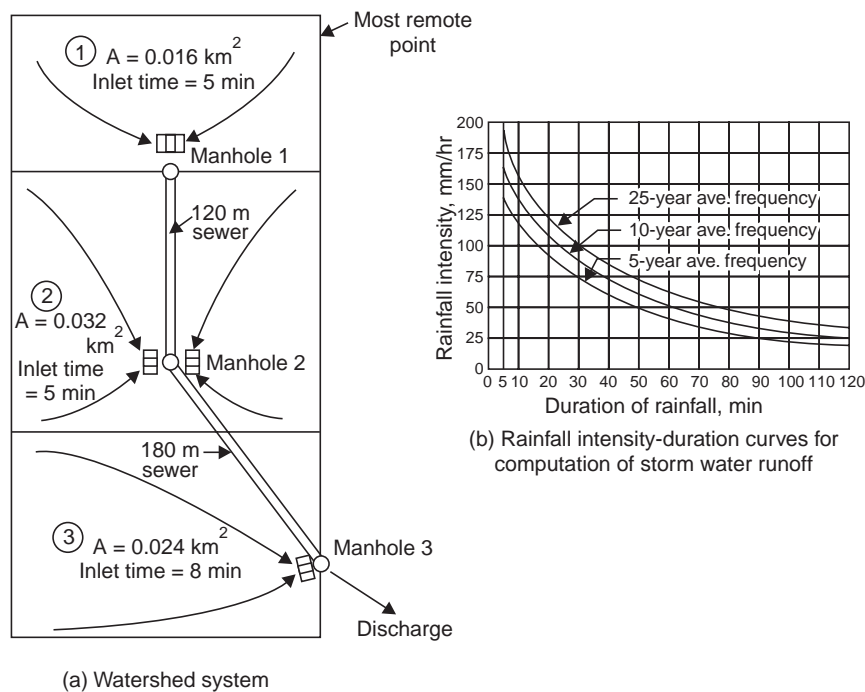

Fig. P.2.27 Storm water drainage project

- 22 Explain step by step the procedure you would adopt to prepare the depth area-duration curves for a particular storm, for a basin having a number of rain-gauges, most of which are recording.
- 23 The isohyets for a 2-day storm on a basin of 1038.3 km² are shown in Fig. P 2.28 and the area between the isohyets as planimeted are given below. Draw the depth-area-duration curve for the basin.

| Zone | Area (km ²) |
|-------|-------------------------|
| I | 63.4 |
| II | 278.0 |
| III | 389.0 |
| IV | 220.0 |
| V | 55.2 |
| VI | 32.7 |
| Total | 1038.3 |

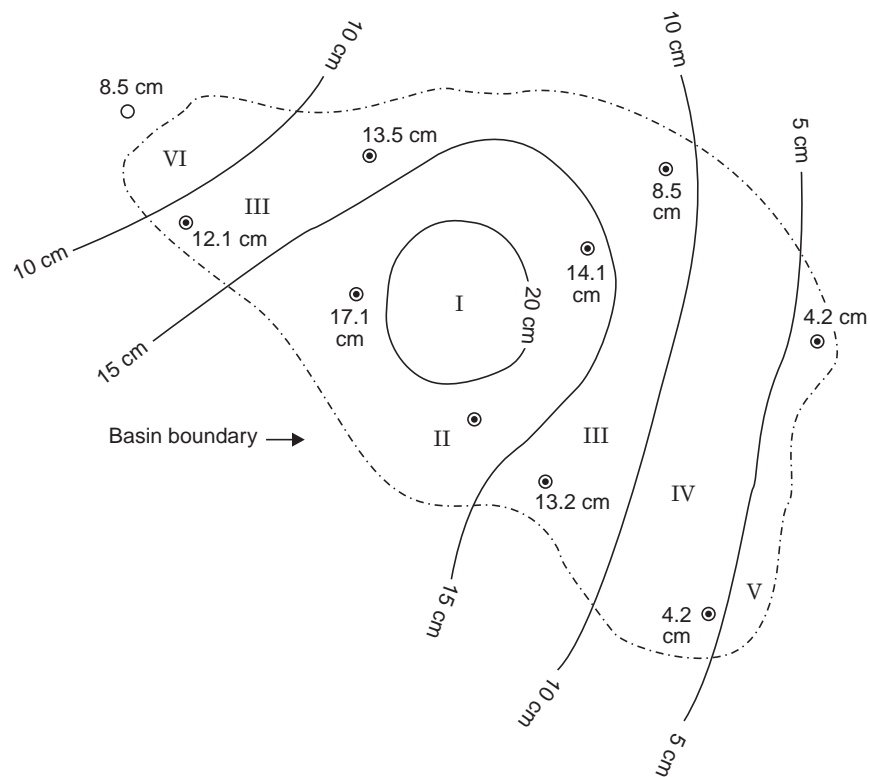

Fig. P2.28 Isohyetal map

24 Write short notes on:

- Isohyet (indicate the annual isohyets of your place)
- A.A.R. (give the a.a.r. of your place)
- Orographic precipitation (give example)
- Depth-area-duration curve
- Double-mass curve
- Cold and warm fronts
- Occlusion
- Cyclones and anticyclones

(i) PMP

(j) Arid, semi-arid and humid regions

(k) Rain-gauge density and its effect on the accuracy of rainfall data

25 Severe Storms during 30 years over a basin gave the following maximum depths of precipitation:

| | | | | | | | |
|------------------|---|----|----|----|----|----|-----|
| Duration (min): | 5 | 10 | 15 | 30 | 60 | 90 | 120 |
| Max. pptn. (mm): | 9 | 12 | 14 | 17 | 22 | 25 | 30 |

Develop a formula for the intensity-duration relationship.

$$\left[i = \frac{285}{t^{0.62}}, \text{ mm / hr} \right].$$

26 The mass curve of precipitation resulted from the storm of 14 August 1983 gave the following results:

| | | | | | | | | | | | |
|-----------|-------|-------|-------|-------|-------|-------|-------|-------|-------|-------|-------|
| Time hr: | 22.00 | 22.05 | 22.10 | 22.15 | 22.20 | 22.25 | 22.30 | 22.35 | 22.40 | 22.45 | 22.50 |
| Depth mm: | 0 | 10.2 | 20.8 | 33.0 | 47.2 | 55.8 | 64.0 | 77.6 | 78.8 | 85.4 | 91.4 |

For the storm construct a hyetograph and draw the maximum-intensity-duration curve.

(IES—1984)

Chapter 3

WATER LOSSES

The hydrologic equation states that

$$\text{Rainfall} - \text{Losses} = \text{Runoff} \quad \dots(3.1)$$

In the previous chapter we studied precipitation and its measurement. The various water losses that occur in nature are enumerated below. If these losses are deducted from the rainfall, the surface runoff can be obtained.

3.1 WATER LOSSES

- (i) Interception loss—due to surface vegetation, *i.e.*, held by plant leaves.
- (ii) Evaporation:
 - (a) from water surface, *i.e.*, reservoirs, lakes, ponds, river channels, etc.
 - (b) from soil surface, appreciably when the ground water table is very near the soil surface.
- (iii) Transpiration—from plant leaves.
- (iv) Evapotranspiration for consumptive use—from irrigated or cropped land.
- (v) Infiltration—into the soil at the ground surface.
- (vi) Watershed leakage—ground water movement from one basin to another or into the sea.

The various water losses are discussed below:

Interception loss—The precipitation intercepted by foliage (plant leaves, forests) and buildings and returned to atmosphere (by evaporation from plant leaves) without reaching the ground surface is called *interception loss*. Interception loss is high in the beginning of storms and gradually decreases; the loss is of the order of 0.5 to 2 mm per shower and it is greater in the case of light showers than when rain is continuous. Fig. 3.1 shows the Horton's mean curve of interception loss for different showers.

$$\text{Effective rain} = \text{Rainfall} - \text{Interception loss}$$

3.2 EVAPORATION

Evaporation from free water surfaces and soil are of great importance in hydro-meteorological studies.

Evaporation from water surfaces (Lake evaporation)

The factors affecting evaporation are air and water temperature, relative humidity, wind velocity, surface area (exposed), barometric pressure and salinity of the water, the last

two having a minor effect. The rate of evaporation is a function of the differences in vapour pressure at the water surface and in the atmosphere, and the Dalton's law of evaporation is given by

$$E = K (e_w - e_a) \quad \dots(3.2)$$

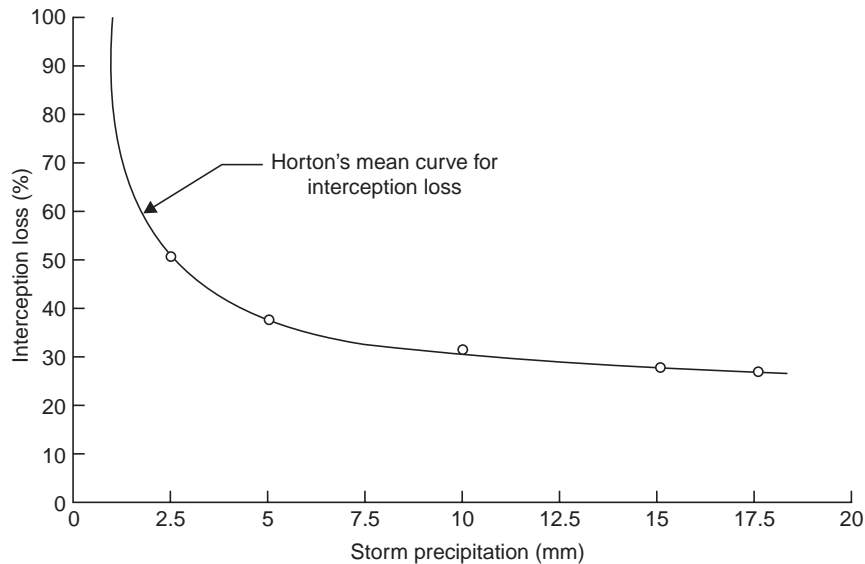

Fig. 3.1 Interception loss (Horton)

where E = daily evaporation

e_w = saturated vapour pressure at the temperature of water

e_a = vapour pressure of the air (about 2 m above)

K = a constant.

i.e., the Dalton's law states that the evaporation is proportional to the difference in vapour pressures e_w and e_a . A more general form of the Eq. (3.2) is given by

$$E = K' (e_w - e_a) (a + bV) \quad \dots(3.3)$$

where K' , a , b = constants and V = wind velocity.

Higher the temperature and wind velocity, greater is the evaporation, while greater the humidity and dissolved salts, smaller is the evaporation. The annual evaporation from irrigation tanks in south India is of the order of 160 to 180 cm, the highest evaporation being in the summer months of April and May. The monthly evaporation from Krishnarajasagara reservoir (near Mysore, south India) is given below:

| Month | Evaporation (cm) | Month | Evaporation (cm) |
|----------|------------------|-----------|------------------|
| January | 11.9 | July | 11.9 |
| February | 10.2 | August | 11.9 |
| March | 12.7 | September | 11.9 |
| April | 17.8 | October | 15.1 |
| May | 20.3 | November | 11.9 |
| June | 15.1 | December | 11.9 |

Methods of Estimating Lake Evaporation

Evaporation from water surfaces can be determined from the following methods :

(i) The storage equation

$$P + I \pm O_g = E + O \pm S \quad \dots(3.4)$$

where P = Precipitation

I = surface inflow

O_g = subsurface inflow or outflow

E = evaporation

O = surface outflow

S = change in surface water storage

(ii) Auxiliary pans like land pans, floating pans, colarado sunken pans, etc.

(iii) Evaporation formula like that of Dalton's law

(iv) Humidity and wind velocity gradients

(v) The energy budget—this method involves too many hydrometeorological factors (variables) with too much sophisticated instrumentation and hence it is a specialist approach

(vi) The water budget—similar to (i)

(vii) Combination of aerodynamic and energy balance equations—Penman's equation (involves too many variables)

3.3 EVAPORATION PANS

(i) *Floating pans* (made of GI) of 90 cm square and 45 cm deep are mounted on a raft floating in water. The volume of water lost due to evaporation in the pan is determined by knowing the volume of water required to bring the level of water up to the original mark daily and after making allowance for rainfall, if there has been any.

(ii) *Land pan*. Evaporation pans are installed in the vicinity of the reservoir or lake to determine the lake evaporation. The IMD Land pan shown in Fig. 3.2 is 122 cm diameter and

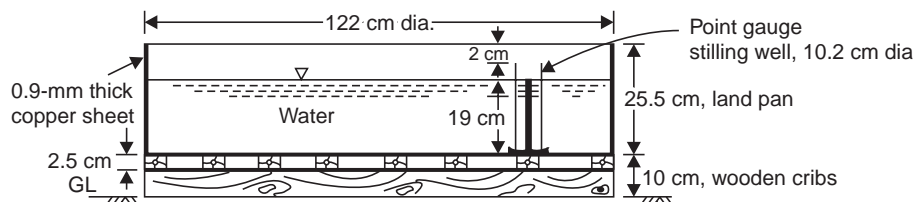

Fig. 3.2 IMD land pan

25.5 cm deep, made of unpainted GI; and set on wood grillage 10 cm above ground to permit circulation of air under the pan. The pan has a stilling well, vernier point gauge, a thermometer with clip and may be covered with a wire screen. The amount of water lost by evaporation from the pan can be directly measured by the point gauge. Readings are taken twice daily at 08.30 and 17.30 hours I.S.T. The air temperature is determined by reading a dry bulb thermometer kept in the Stevenson's screen erected in the same enclosure of the pan. A totalising anemometer is normally mounted at the level of the instrument to provide the wind speed information

required. Allowance has to be made for rainfall, if there has been any. Water is added to the pan from a graduated cylinder to bring the water level to the original mark, *i.e.*, 5 cm below the top of the pan. Experiments have shown that the unscreened pan evaporation is 1.144 times that of the screened one.

(iii) *Colorado sunken pan.* This is 92 cm square and 42-92 cm deep and is sunk in the ground such that only 5-15 cm depth projects above the ground surface and thus the water level is maintained almost at the ground level. The evaporation is measured by a point gauge.

Pan coefficient—Evaporation pan data cannot be applied to free water surfaces directly but must be adjusted for the differences in physical and climatological factors. For example, a lake is larger and deeper and may be exposed to different wind speed, as compared to a pan. The small volume of water in the metallic pan is greatly affected by temperature fluctuations in the air or by solar raditions in contrast with large bodies of water (in the reservoir) with little temperature fluctuations. Thus the pan evaporation data have to be corrected to obtain the actual evaporation from water surfaces of lakes and reservoirs, *i.e.*, by multiplying by a coefficient called pan coefficient and is defined as

$$\text{Pan coefficient} = \frac{\text{Lake evaporation}}{\text{Pan evaporation}} \quad \dots(3.5)$$

and the experimental values for pan coefficients range from 0.67 to 0.82 with an average of 0.7.

Example 3.1 *The following are the monthly pan evaporation data (Jan.-Dec.) at Krishnarajasagara in a certain year in cm.*

16.7, 14.3, 17.8, 25.0, 28.6, 21.4

16.7, 16.7, 16.7, 21.4, 16.7, 16.7

The water spread area in a lake nearby in the beginning of January in that year was 2.80 km² and at the end of December it was measured as 2.55 km². Calculate the loss of water due to evaporation in that year. Assume a pan coefficient of 0.7.

Solution Mean water spread area of lake

$$\begin{aligned} A_{\text{ave}} &= \frac{1}{3} (A_1 + A_2 + \sqrt{A_1 A_2}), && \text{cone formula} \\ &= \frac{1}{3} (2.80 + 2.55 + \sqrt{2.80 \times 2.55}) \\ &= 2.673 \text{ km}^2 \end{aligned}$$

$$\begin{aligned} \text{Annual loss of water due to evaporation (adding up the monthly values)} \\ &= 228.7 \text{ cm} \end{aligned}$$

$$\begin{aligned} \text{Annual volume of water lost due to evaporation} \\ &= (2.673 \times 10^6) \times \frac{228.7}{100} \times 0.7 \\ &= 4.29 \times 10^6 \text{ m}^3 \text{ or } \mathbf{4.29 \text{ Mm}^3} \end{aligned}$$

Example 3.1 (a) *Compute the daily evaporation from a Class A pan if the amounts of water added to bring the level to the fixed point are as follows:*

| | | | | | | | |
|-------------------|----|-----------|----|---|---|---|---|
| Day: | 1 | 2 | 3 | 4 | 5 | 6 | 7 |
| Rainfall (mm): | 14 | 6 | 12 | 8 | 0 | 5 | 6 |
| Water added (mm): | -5 | 3 | 0 | 0 | 7 | 4 | 3 |
| | | (removed) | | | | | |

What is the evaporation loss of water in this week from a lake (surface area = 640 ha) in the vicinity, assuming a pan coefficient of 0.75?

| | | | | | | | |
|---|-----------------|-------|----|---|---|-------|-------|
| | + water added | | | | | | |
| Solution Pan evaporation, E_p , mm = | Rainfall or | | | | | | |
| | – water removed | | | | | | |
| Day: | 1 | 2 | 3 | 4 | 5 | 6 | 7 |
| E_p : | 14 – 5 | 6 + 3 | 12 | 8 | 7 | 5 + 4 | 6 + 3 |
| (mm): | = 9 | = 9 | | | | = 9 | = 9 |

$$\text{Pan evaporation in the week} = \sum_{1}^{7} E_p = 63 \text{ mm}$$

$$\text{Pan coefficient} \quad 0.75 = \frac{E_L}{E_p}$$

$$\begin{aligned} \therefore \text{Lake evaporation during the week } E_L \\ = 63 \times 0.75 = 47.25 \text{ mm} \end{aligned}$$

$$\text{Water lost from the lake} = A \cdot E_L = 640 \times \frac{47.25}{1000} = 30.24 \text{ ha.m} \approx \mathbf{0.3 \text{ Mm}^3}$$

Example 3.1 (b) The total observed runoff volume during a storm of 6-hr duration with a uniform intensity of 15 mm/hr is 21.6 Mm³. If the area of the basin is 300 km², find the average infiltration rate and the runoff coefficient for the basin.

Solution (i) Infiltration loss F_p = Rainfall (P) – Runoff (R)

$$\begin{aligned} &= 15 \times 6 - \frac{21.6 \times 10^6 \text{ m}^3}{300 \times 10^6 \text{ m}^2} \times 1000 \\ &= 90 - 72 = 18 \text{ mm} \end{aligned}$$

$$f_{\text{ave}} = \frac{F_p}{t} = \frac{18 \text{ mm}}{6 \text{ hr}} = \mathbf{3 \text{ mm/hr}}$$

(ii) Yield = C A P

$$21.6 \times 10^6 \text{ m}^3 = C(300 \times 10^6 \text{ m}^2) \frac{90}{1000}$$

$$\therefore \quad \mathbf{C = 0.8}$$

Piche Evaporimeter

It is usually kept suspended in a Stevenson screen. It consists of a disc of filter paper kept constantly saturated with water from a graduated glass tube Fig. 3.3. The loss of water from the tube over a known period gives the average rate of evaporation. Though it is a simple instrument, the readings obtained are often more erratic than those from standard pans.

Measures to Reduce Lake Evaporation

The following are some of the recommended measures to reduce evaporation from water surfaces :

(i) Storage reservoirs of more depth and less surface area, *i.e.*, by choosing a cross section of the reservoir like a deep gorge Fig. 3.4 ; while the surface water is exposed to temperature gradients the deeper waters are cool; from this standpoint a large reservoir is preferable to a number of small reservoirs (while it is the reverse from the point of flood control).

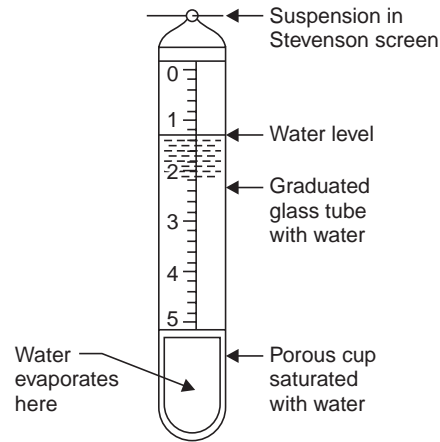

Fig. 3.3. Piche evaporimeter

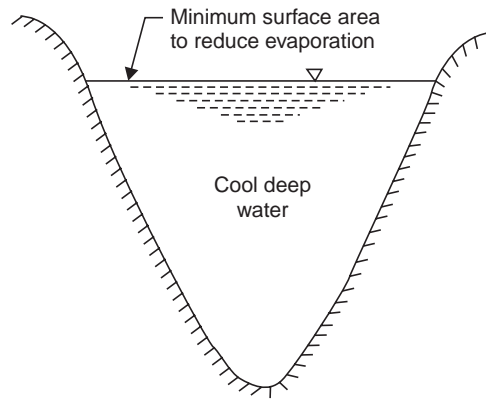

Fig. 3.4 Reservoir in a deep gorge

(ii) By growing tall trees like *Causerina* on the windward side of the reservoirs to act as wind breakers.

(iii) By spraying certain chemicals or fatty acids and formation of films. By spreading a monomolecular layer of acetyl alcohol (hexadecanol) $C_{16}H_{33}OH$ over the reservoir surface (from boats)—a film is formed on the surface which is only 0.015 micron (approx.) in thickness. It is a polar compound and it has great affinity for water on one side (hydrophylic) and repels water on the other side (hydrophobic). The film will only allow precipitation from the top into it but will not allow water molecules to escape from it. This method is readily effective when the wind velocities are less. If the wind velocity is more, it will sweep the film off the water surface and deposit it on the bank. However the film is pervious to O_2 and CO_2 . About 2.2 kg (22 N) of acetyl alcohol is required to cover an area of 1 ha of reservoir surface. It is best suited for small and medium size reservoirs.

(iv) By allowing flow of water, temperature is reduced and evaporation is reduced; *i.e.*, by designing the outlet works so that the warmer surface water can be released.

(v) By removing the water loving weeds and plants like Phreatophytes from the periphery of the reservoir.

(vi) By straightening the stream-channels the exposed area of the water surface (along the length) is reduced and hence evaporation is reduced.

(vii) By providing mechanical coverings like thin polythene sheets to small agricultural ponds and lakes.

(viii) By developing underground reservoirs, since the evaporation from a ground water table is very much less than the evaporation from a water surface.

(ix) If the reservoir is surrounded by huge trees and forest, the evaporation loss will be less due to cooler environment.

3.4 SOIL EVAPORATION

The evaporation from a wet soil surface immediately after rain or escape of water molecules with more resistance when the water table lies within a metre from the ground is called *soil evaporation*. This, expressed as a percentage of evaporation from free water surface is called evaporation opportunity.

$$\text{Evaporation opportunity} = \frac{\text{Actual evaporation from the land (soil) at a given time}}{\text{Evaporation from an equivalent water surface}} \times 100 \quad \dots(3.6)$$

Soil evaporation will continue at a high rate for some time after the cessation of rainfall, then decreases as the ground surface starts drying, until a constant rate is reached which is dependent on the depth of the water table and nature of the soil in addition to meteorological conditions.

Measurement of soil evaporation can be done with tanks (lysimeters) filled with earth and with the surface almost flush with the ground Fig. 3.5. To measure the evaporation from a soil whose surface is within the capillary fringe, tanks equipped to maintain the water table at any desired elevation may be used. The soil evaporation is determined by weighing the tanks at stated intervals and knowing the amount of water that was added in the interim.

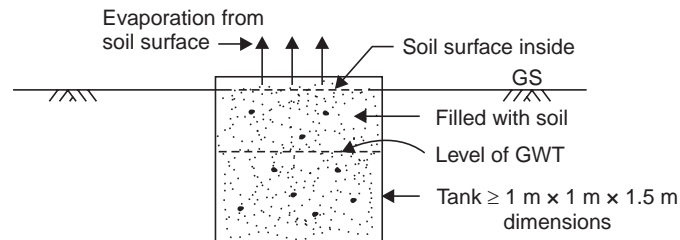

Fig. 3.5 Lysimeter for soil evaporation

3.5 UNSATURATED FLOW

Soil moisture in the unsaturated zone moves under the influence of the gravitational force and the force due to the difference in capillary potential. The capillary flow is given by Darcy's law.

$$Q = K_u i A \quad \dots(3.7)$$

$$i = \frac{\Delta Z}{l} + \frac{\Delta h}{l} \quad \dots(3.7 a)$$

where Q = capillary flow

K_u = coefficient of unsaturated permeability

i = sum of the gradients of capillary potential and gravitational force

A = area of cross section of capillary flow

ΔZ = difference in elevation of the two points A and B (if the flow is from A to B).

Δh = difference in capillary potential of the two points A and B

l = length of travel

when the capillary potential becomes greater than the gravitational potential there is upward movement of soil moisture resulting in loss of water due to soil evaporation. When the flow is upward, the gravitational component of ' i ' must be subtracted from the capillary potential component. For horizontal flow the gravitational component is zero. For downward flow the two motivating forces act in the same direction. The coefficient of unsaturated permeability increases as the soil moisture increases.

3.6 TRANSPIRATION

Transpiration is the process by which the water vapour escapes from the living plant leaves and enters the atmosphere. Various methods are devised by botanists for the measurement of transpiration and one of the widely used methods is by phytometer. It consists of a closed water tight tank with sufficient soil for plant growth with only the plant exposed; water is applied artificially till the plant growth is complete. The equipment is weighed in the beginning (W_1) and at the end of the experiment (W_2). Water applied during the growth (w) is measured and the water consumed by transpiration (W_t) is obtained as

$$W_t = (W_1 + w) - W_2 \quad \dots(3.8)$$

The experimental values (from the protected growth of the plant in the laboratory) have to be multiplied by a coefficient to obtain the possible field results.

Transpiration ratio is the ratio of the weight of water absorbed (through the root system), conveyed through and transpired from a plant during the growing season to the weight of the dry matter produced exclusive of roots.

$$\text{Transpiration ratio} = \frac{\text{weight of water transpired}}{\text{weight of dry matter produced}} \quad \dots(3.9)$$

For the weight of dry matter produced, sometimes, the useful crop such as grains of wheat, gram, etc. are weighed. The values of transpiration ratio for different crops vary from 300 to 800 and for rice it varies from 600 to 800 the average being 700.

Evaporation losses are high in arid regions where water is impounded while transpiration is the major water loss in humid regions.

3.7 EVAPOTRANSPIRATION

Evapotranspiration (E_t) or consumptive use (U) is the total water lost from a cropped (or irrigated) land due to evaporation from the soil and transpiration by the plants or used by the plants in building up of plant tissue. Potential evapotranspiration (E_{pt}) is the evapotranspiration from the short green vegetation when the roots are supplied with unlimited water covering the soil. It is usually expressed as a depth (cm, mm) over the area.

Estimation of Evapotranspiration

The following are some of the methods of estimating evapotranspiration:

- (i) Tanks and lysimeter experiments
- (ii) Field experimental plots
- (iii) Installation of sunken (colarado) tanks
- (iv) Evapotranspiration equations as developed by Lowry-Johnson, Penman, Thornthwaite, Blaney-Criddle, etc.
- (v) Evaporation index method, *i.e.*, from pan evaporation data as developed by Hargreaves and Christiansen.

For detailed discussions of the above methods reference may be made to the author's companion volume on 'Ground Water' published by Wiley Eastern Limited, New Delhi, 1981. However, two well known methods are discussed here.

(i) *Blaney-Criddle method.* This method is used throughout the world for the consumptive use determinations and is given by :

$$U = \Sigma \frac{ktp}{100} \quad \text{in FPS units} \quad \dots(3.10)$$

and
$$U = \Sigma \frac{kp(4.6t + 81.3)}{100} \quad \text{in metric units} \quad \dots(3.10 a)$$

$$U = \Sigma kf = K \Sigma f = KF \quad \dots(3.10 b)$$

$$f = \frac{tp}{100} \quad \text{in FPS units} \quad \dots(3.10 c)$$

$$f = \frac{p(4.6t + 81.3)}{100} \quad \text{in metric units} \quad \dots(3.10 d)$$

where U = seasonal consumptive use (inches in FPS units and cm in metric units)

t = mean monthly temperature ($^{\circ}\text{F}$ in FPS units and $^{\circ}\text{C}$ in metric units)

p = monthly percentage of hours of bright sunshine (of the year)

k = monthly consumptive use coefficient determined from experimental data

f = monthly consumptive use factor

K, F = seasonal values of consumptive use coefficient and factor, respectively

Σ refers for the summation for all the months of the growing season.

Example 3.2 Determine the evapotranspiration and irrigation requirement for wheat, if the water application efficiency is 65% and the consumptive use coefficient for the growing season is 0.8 from the following data :

| Month | Mean monthly temp ($^{\circ}\text{C}$) | Monthly percentage of sunshine (hours) | Effective rainfall (cm) |
|----------|--|--|-------------------------|
| November | 18 | 7.20 | 2.6 |
| December | 15 | 7.15 | 2.8 |
| January | 13.5 | 7.30 | 3.5 |
| February | 14.5 | 7.10 | 2.0 |

Solution

| Month | Mean monthly temp. (°C) t | Monthly % of sunshine (hours) p | Effective rainfall (cm) P_e | Monthly consumptive use factor $f = \frac{p(4.6t + 81.3)}{100}$ |
|-------|--------------------------------|--------------------------------------|----------------------------------|--|
| Nov. | 18 | 7.20 | 2.6 | 11.82 |
| Dec. | 15 | 7.15 | 2.8 | 10.74 |
| Jan. | 13.5 | 7.30 | 3.5 | 10.48 |
| Feb. | 14.5 | 7.10 | 2.0 | 10.50 |
| | | | $\Sigma P_e = 10.9$ | $\Sigma f = 43.54$ |

$$\begin{aligned} \text{Seasonal consumptive use, } U &= K \Sigma f \\ &= 0.8 \times 43.54 \\ &= \mathbf{34.83 \text{ cm}} \end{aligned}$$

Field irrigation requirement,

$$\text{F.I.R.} = \frac{U - \Sigma P_e}{\eta_i} \quad \dots(3.11)$$

where η_i = water application efficiency
F.I.R. = Field irrigation requirement

$$\therefore \text{F.I.R.} = \frac{34.83 - 10.90}{0.65} = \mathbf{36.9 \text{ cm}}$$

(ii) *Evaporation Index method.* Analysis of data on consumptive use indicate a high degree of correlation between pan evaporation values and consumptive use. The relationship between the evapotranspiration (E_t) and pan evaporation (E_p) is usually expressed as

$$E_t = kE_p \quad \dots(3.12)$$

where k is a coefficient (*i.e.*, E_t/E_p ratio) and is found to vary according to the stage of growth of the crop. The values of k for different crops at 5% increments of the crop growing season are presented by G.H. Hargreaves.

Example 3.3 Assuming a growing season of 4 months December-March for wheat, determine the consumptive use of wheat in the month of January if the pan evaporation for the month is 9.5 cm. Take the consumptive use coefficient at 40%, stage growth of the crop as 0.52.

$$\text{Solution} \quad E_t = kE_p$$

The crop season is December to March *i.e.*, 120 days. By middle of January the number of days of growth is 47, *i.e.*, $\frac{47}{120} = 0.40$ or 40% stage growth of the crop has reached and k for this stage is 0.52 and E_p for the month of January is 9.5 cm.

$$\therefore E_t = 0.52 \times 9.5 = \mathbf{4.94 \text{ cm}}$$

The daily consumptive use for the month of January

$$= \frac{4.94 \times 10}{31} = \mathbf{1.6 \text{ mm/day}}$$

Factors Affecting Evapotranspiration

From the above equations it can be seen that the following factors affect the evapotranspiration:

- (i) Climatological factors like percentage sunshine hours, wind speed, mean monthly temperature and humidity.
- (ii) Crop factors like the type of crop and the percentage growing season.
- (iii) The moisture level in the soil.

3.8 HYDROMETEOROLOGY

Hydrometeorology is the science which deals with the movement of water and water vapour in the atmosphere. A typical hydro-meteorological set-up at Regional Agricultural Research Station, Aduturai, Thanjavur District, Tamil Nadu is given below:

- (i) Wind vane with cardinal points NSE & W mounted on a masonry pillar.
 - (ii) Cup Counter anemometer (three cups) mounted on a masonry pillar.
 - (iii) Rain gauge with inner can fixed on a masonry platform. Top of rain gauge was 30 cm above ground level.
 - (iv) Sunshine recorder mounted on masonry pillar. The number of sunshine hours per day are recorded on a strip of cardboard, a spherical magnifying glass burning a hole in the middle of the cardboard strip whenever the sun is out.
 - (v) *Stevenson's Screen*. Double louvred, holding maximum and minimum thermometers and Dry and Wet Bulb thermometers; and PICHE Evaporimeter kept suspended.
 - (vi) Assmann Hygrometer with hand driven aspiration fan and insulated thermometers; wooden framework erected on the ground for keeping the hygrometer at different heights.
 - (vii) *Dew gauge*. Stand with four exposure brackets (two on either side) with chocolate coloured blocks of wood and book of dew scale standards.
 - (viii) Soil Temperature thermometers with stems bent—3 numbers embedded at 5, 15 and 30 cm in the soil.
 - (ix) IMD Land pan with stilling well and Vernier Hook gauge placed on a wooden frame work 10 cm in depth. The pan is covered with a wire screen (chicken wire).
- All the measurements are taken twice a day at 07-12 and 14-12 hours IST in the station.

3.9 INFILTRATION

Water entering the soil at the ground surface is called infiltration. It replenishes the soil moisture deficiency and the excess moves downward by the force of gravity called deep seepage or percolation and builds up the ground water table. The maximum rate at which the soil in any given condition is capable of absorbing water is called its infiltration capacity (f_p). Infiltration (f) often begins at a high rate (20 to 25 cm/hr) and decreases to a fairly steady state rate (f_c) as the rain continues, called the ultimate f_p (= 1.25 to 2.0 cm/hr) (Fig. 3.6). The infiltration rate (f) at any time t is given by Horton's equation.

$$f = f_c + (f_0 - f_c) e^{-kt} \quad \dots(3.13)$$

$$k = \frac{f_0 - f_c}{F_c} \quad \dots(3.13 a)$$

- where f_0 = initial rate of infiltration capacity
 f_c = final constant rate of infiltration at saturation
 k = a constant depending primarily upon soil and vegetation
 e = base of the Napierian logarithm
 F_c = shaded area in Fig. 3.6
 t = time from beginning of the storm

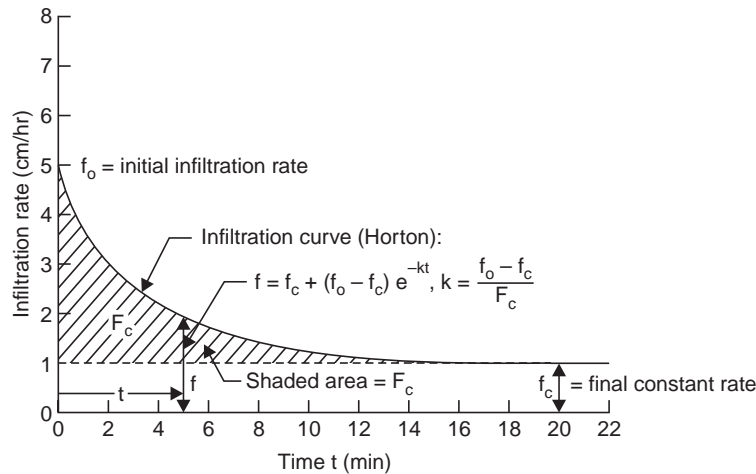

Fig. 3.6 Infiltration Curve (Horton)

The infiltration takes place at capacity rates only when the intensity of rainfall equals or exceeds f_p ; i.e., $f = f_p$ when $i \geq f_p$; but when $i < f_p$, $f < f_p$ and the actual infiltration rates are approximately equal to the rainfall rates.

The infiltration depends upon the intensity and duration of rainfall, weather (temperature), soil characteristics, vegetal cover, land use, initial soil moisture content (initial wetness), entrapped air and depth of the ground water table. The vegetal cover provides protection against rain drop impact and helps to increase infiltration.

Methods of Determining Infiltration

The methods of determining infiltration are:

- (i) Infiltrimeters
- (ii) Observation in pits and ponds
- (iii) Placing a catch basin below a laboratory sample
- (iv) Artificial rain simulators
- (v) Hydrograph analysis

(i) *Double-ring infiltrometer*. A double ring infiltrometer is shown in Fig. 3.7. The two rings (22.5 to 90 cm diameter) are driven into the ground by a driving plate and hammer, to penetrate into the soil uniformly without tilt or undue disturbance of the soil surface to a depth of 15 cm. After driving is over, any disturbed soil adjacent to the sides tamped with a metal tamper. Point gauges are fixed in the centre of the rings and in the annular space between the two rings. Water is poured into the rings to maintain the desired depth (2.5 to 15 cm with a minimum of 5 mm) and the water added to maintain the original constant depth at

regular time intervals (after the commencement of the experiment) of 5, 10, 15, 20, 30, 40, 60 min, etc. up to a period of at least 6 hours is noted and the results are plotted as infiltration rate in cm/hr versus time in minutes as shown in Fig. 3.8. The purpose of the outer tube is to eliminate to some extent the edge effect of the surrounding drier soil and to prevent the water within the inner space from spreading over a larger area after penetrating below the bottom of the ring.

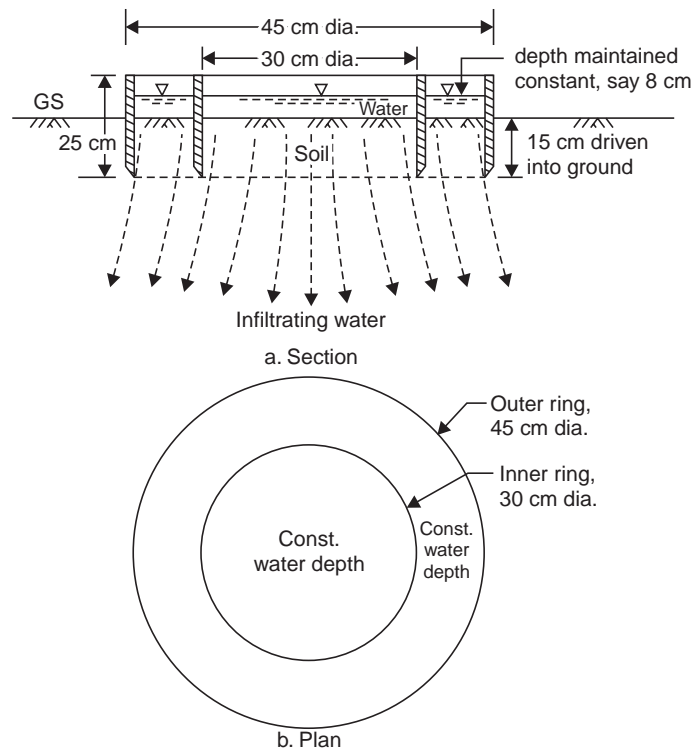

Fig. 3.7 Double ring infiltrometer

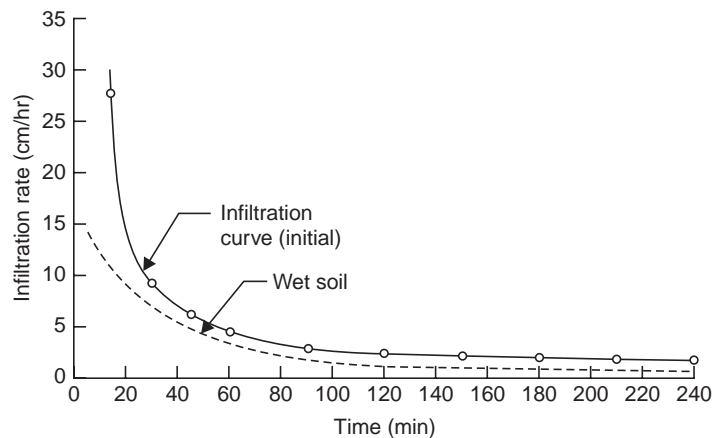

Fig. 3.8 Typical infiltration curve

Tube infiltrometer. This consists of a single tube about 22.5 cm diameter and 45 to 60 cm long which is driven into the ground atleast to a depth up to which the water percolates during the experiment and thus no lateral spreading of water can occur (Fig. 3.9). The water added into the tube at regular time intervals to maintain a constant depth is noted from which the infiltration curve can be drawn.

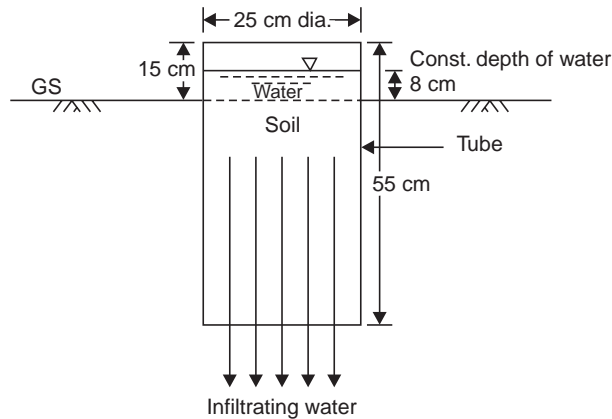

Fig. 3.9 Tube infiltrometer

Example 3.4 For a given basin, the following are the infiltration capacity rates at various time intervals after the beginning of the storm. Make a plot of the *f*-curve and establish an equation of the form developed by Horton. Also determine the total rain and the excess rain (runoff).

| Time (min) | Precipitation rate (cm/hr) | Infiltration capacity (cm/hr) |
|---------------|-------------------------------|----------------------------------|
| 1 | 5.0 | 3.9 |
| 2 | 5.0 | 3.4 |
| 3 | 5.0 | 3.1 |
| 4 | 5.0 | 2.7 |
| 5 | 5.0 | 2.5 |
| 6 | 7.5 | 2.3 |
| 8 | 7.5 | 2.0 |
| 10 | 7.5 | 1.8 |
| 12 | 7.5 | 1.54 |
| 14 | 7.5 | 1.43 |
| 16 | 2.5 | 1.36 |
| 18 | 2.5 | 1.31 |
| 20 | 2.5 | 1.28 |
| 22 | 2.5 | 1.25 |
| 24 | 2.5 | 1.23 |
| 26 | 2.5 | 1.22 |
| 28 | 2.5 | 1.20 |
| 30 | 2.5 | 1.20 |

Solution The precipitation and infiltration rates versus time are plotted as shown in Fig. 3.10. In the Hortons equation, the Horton's constant

$$k = \frac{f_0 - f_c}{F_c}$$

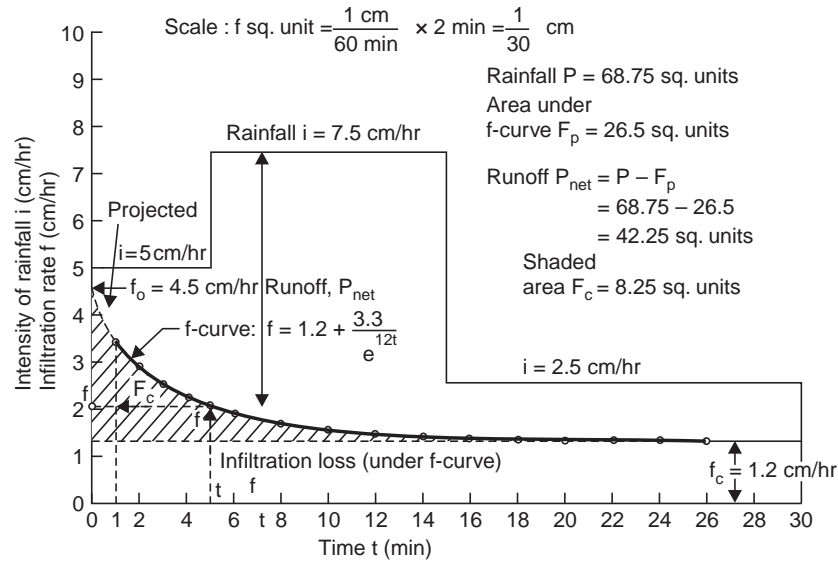

Fig. 3.10 Infiltration loss and net rain (Example 3.4)

From Fig. 3.10, shaded area

$$\begin{aligned} F_c &= 8.25 \text{ sq. units} \\ &= 8.25 \left(\frac{1 \text{ cm}}{60 \text{ min}} \times 2 \text{ min} \right) = 8.25 \times \frac{1}{30} \\ &= \mathbf{0.275 \text{ cm}} \end{aligned}$$

$$\therefore k = \frac{(4.5 - 1.2) \text{ cm/hr}}{0.275 \text{ cm}} = \mathbf{12 \text{ hr}^{-1}}$$

The Hortons equation is

$$f = f_c + (f_0 - f_c)e^{-kt} = 1.2 + (4.5 - 1.2)e^{-12t}$$

$$\therefore \mathbf{f = 1.2 + \frac{3.3}{e^{12t}}}$$

is the equation for the infiltration capacity curve (f -curve) for the basin, where f is in cm/hr and t in hr.

$$\text{For example, for } t = 10 \text{ min} = \frac{10}{60} = \frac{1}{6} \text{ hr}$$

$$f = 1.2 + \frac{3.3}{e^{12 \times 1/6}} = 1.7 \text{ cm/hr, which is very near compared}$$

to the observed value of 1.8 cm/hr.

$$\text{Total rain } P = 68.75 \text{ sq. units} = 68.75 \times \frac{1}{30} = \mathbf{2.29 \text{ cm}}$$

$$\begin{aligned} \text{Excess rain } P_{\text{net}} &= P - F_p \\ &= 68.75 - 26.5 = 42.25 \text{ sq. units} \\ &= 42.25 \times \frac{1}{30} = \mathbf{1.41 \text{ cm}} \end{aligned}$$

$$\text{Total infiltration } F_p = 26.5 \times \frac{1}{30} = 0.88 \text{ cm}$$

The total infiltration loss F_p can also be determined by intergrating the Hortons equation for the duration of the storm.

$$\begin{aligned} F_p &= \int_0^t f dt = \int_0^{30/60} \left(1.2 + \frac{3.3}{e^{12t}} \right) dt \\ &= 1.2t + \frac{3.3}{-12e^{12t}} \Bigg|_0^{30/60} \\ &= \left[1.2 \times \frac{30}{60} - \frac{3.3}{12e^{12 \times 30/60}} \right] - \left[0 - \frac{3.3}{12e^0} \right] \\ &= 0.6 + \frac{3.3}{12} \left(1 - \frac{1}{e^6} \right) \\ &= 0.6 + \frac{3.3}{12} \left(1 - \frac{1}{408} \right) \\ &= \mathbf{0.88 \text{ cm}} \end{aligned}$$

$$\begin{aligned} \therefore P_{\text{net}} &= P - F_p \\ &= 2.29 - 0.88 \\ &= \mathbf{1.41 \text{ cm}} \end{aligned}$$

which compares with the value obtained earlier.

$$\text{Ave. infiltration loss } f_{\text{ave}} = \frac{F_p}{t} = \frac{0.88 \text{ cm}}{1/2 \text{ hr}} = \mathbf{1.76 \text{ cm/hr}}$$

To determine the Horton's constant by drawing a semi-log plot of t vs. $(f - f_c)$:

The Horton's equation is

$$f = f_c + (f_0 - f_c)e^{-kt}$$

$$\therefore \log(f - f_c) = \log(f_0 - f_c) - kt \log e$$

Solving for t ,

$$t = \frac{\log(f_0 - f_c)}{k \log e} - \frac{\log(f - f_c)}{k \log e}$$

which is in the form of a straight line $y = mx + c$ in which $y = t$, $x = \log(f - f_c)$, $m = -\frac{1}{k \log e}$.

Hence, from a plot of t vs. $(f - f_c)$ on a semi-log paper (t to linear scale), the constants in the Horton's equation can be determined.

From the given data, $f_c = 1.2$ cm/hr and the values of $(f - f_c)$ for different time intervals from the beginning are: 2.7, 2.2, 1.9, 1.5, 1.3, 1.1, 0.8, 0.6, 0.46, 0.32, 0.22, 0.16, 0.12, 0.05, 0.04, 0.02, 0.0 cm/hr, respectively ; (note: $3.9 - 1.2 = 2.7$ cm/hr and like that for other readings).

These values are plotted against time on a semi-log paper as shown in Fig. 3.11.

From Fig. 3.11, $m = -0.1933 = -\frac{1}{k \log e}$

$\log e = 0.434 \quad \therefore k = \frac{1}{0.1933 \times 0.434} = 12 \text{ hr}^{-1}$

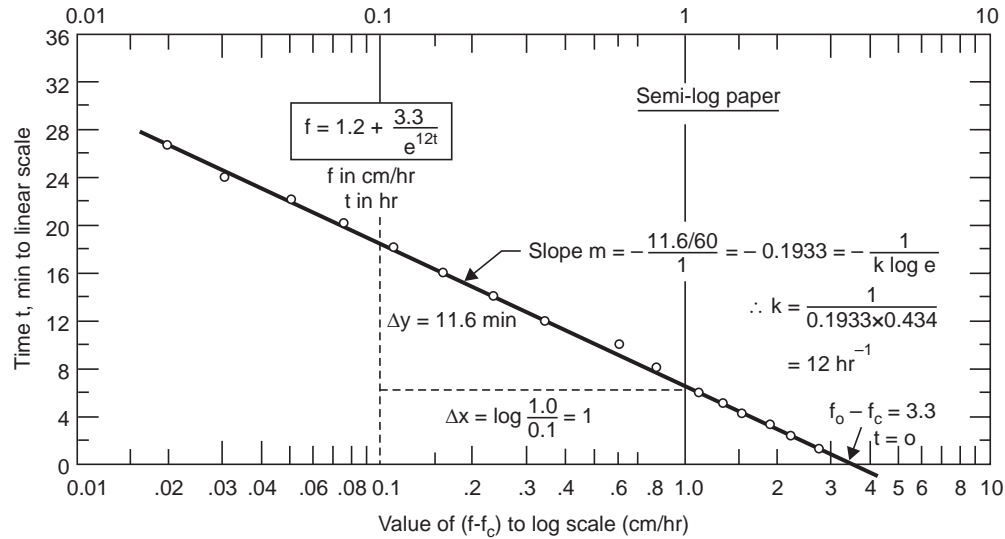

Fig. 3.11 Semi-log plot for infiltration constants (Example 3.4)

Also from the graph, when $t = 0$,

$$f - f_c = 3.3 = f_0 - f_c, \text{ (since } f = f_0 \text{ when } t = 0)$$

$$\therefore f_0 = 3.3 + 1.2 = 4.5 \text{ cm/hr}$$

Hence, the Hortons equation is of the form

$$f = 1.2 + (4.5 - 1.2)e^{-12t}$$

or

$$f = 1.2 + \frac{3.3}{e^{12t}}$$

where f is in cm/hr and t in hr.

$$\begin{aligned} \text{Total rain } P &= 5 \times \frac{5}{60} + 7.5 \times \frac{10}{60} + 2.5 \times \frac{15}{60} \\ &= 2.29 \text{ cm} \end{aligned}$$

$$\text{Infiltration loss } F_p = 0.88 \text{ cm}$$

$$\begin{aligned} \therefore \text{Excess rain (runoff), } P_{\text{net}} &= P - F_p \\ &= 2.29 - 0.88 \\ &= 1.41 \text{ cm} \end{aligned}$$

which compares with the value obtained earlier.

(ii) *Observation from infiltration pits and ponds.* By noting the depression in the level of water in the pits and ponds and deducting the loss due to evaporation, an idea about the infiltration rates in such soils can be obtained.

(iii) By placing a catch basin called a *lysimeter* under a laboratory sample or at some depth below the land surface, the infiltrating water can be measured and the infiltration rate in the soil can be obtained.

(iv) *Artificial rain simulators* on a small area of land of 0.1 to 50 m², water is applied by artificial showers at a uniform rate. The resulting surface runoff is measured and the infiltration capacity of the soil is determined.

(v) *Hydrograph analysis*. By knowing accurately the varying intensities of rainfall during a storm and the continuous record of the resulting runoff, the infiltration capacity can be determined and is discussed in the next chapter.

Example 3.4 (a) For a small catchment, the infiltration rate at the beginning of rain was observed to be 90 mm/hr and decreased exponentially to a constant rate of 8 mm/hr after $2\frac{1}{2}$ hr. The total infiltration during $2\frac{1}{2}$ hr was 50 mm. Develop the Horton's equation for the infiltration rate at any time $t < 2\frac{1}{2}$ hr.

Solution
$$k = \frac{f_0 - f_c}{F_c} = \frac{90 - 8}{50 - 8 \times 2.5} = 2.73 \text{ hr}^{-1}$$

Horton's eqn.:
$$f = f_c + (f_0 - f_c)e^{-kt} = 8 + (90 - 8)e^{-2.73 t}$$

or
$$\mathbf{f = 8 + 82e^{-2.73 t}}, \quad f \text{ in mm/hr, } t \text{ in hr.}$$

Example 3.5 A 24-hour storm occurred over a catchment of 1.8 km² area and the total rainfall observed was 10 cm. An infiltration capacity curve prepared had the initial infiltration capacity of 1 cm/hr and attained a constant value of 0.3 cm/hr after 15 hours of rainfall with a Horton's constant $k = 5 \text{ hr}^{-1}$. An IMD pan installed in the catchment indicated a decrease of 0.6 cm in the water level (after allowing for rainfall) during 24 hours of its operation. Other losses were found to be negligible. Determine the runoff from the catchment. Assume a pan coefficient of 0.7.

Solution
$$F_p = \int_0^{24} [f_c + (f_0 - f_c)e^{-kt}] dt = \int_0^{24} [0.3 + (1.0 - 0.3)e^{-5t}] dt$$

$$= \left[0.3t + \frac{0.7}{-5e^{5t}} \right]_0^{24}$$

$$= \left[0.3 \times 24 - \frac{0.7}{5e^{5 \times 24}} \right] - \left[0 - \frac{0.7}{5e^0} \right]$$

$$= 7.2 + \frac{0.7}{5} \left(1 - \frac{1}{e^{120}} \right) = 7.34 \text{ cm}$$

$$\text{Runoff} = P - F_p - E = 10 - 7.34 - (0.60 \times 0.7)$$

$$= \mathbf{2.24 \text{ cm}}$$

Volume of runoff from the catchment

$$= \frac{2.24}{100} (1.8 \times 10^6) = \mathbf{40320 \text{ m}^3}$$

Example 3.5 (a) In a double ring infiltrometer test, a constant depth of 100 mm was restored at every time interval the level dropped as given below:

| | | | | | | | | | | | |
|---------------------|-----|----|----|----|----|----|----|----|----|-----|-----|
| Time (min) | 0 | 5 | 10 | 15 | 25 | 45 | 60 | 75 | 90 | 110 | 130 |
| Depth of water (mm) | 100 | 83 | 87 | 90 | 85 | 78 | 85 | 85 | 85 | 80 | 80 |

(i) Establish the infiltration equation of the form developed by Horton.

(ii) Obtain the equation for cumulative infiltration of the form (a) $F = at^n$ (b) $F = at^n + b$.

Solution

| Time t (min) | Depth to water Surface (mm) | | Depth of infiltration d (mm) | Infiltration rate $f = \frac{d}{\Delta t} \times 60$ (mm/hr) | Cumulative infiltration $F = \Sigma d$ mm | $f_c = 60$ mm/hr $f - f_c$ mm/hr |
|----------------|-----------------------------|---------------|--------------------------------|--|---|-------------------------------------|
| | Before filling | After filling | | | | |
| 0 | 100 | — | 0 | f_0 | 0 | — |
| 5 | 83 | 100 | 17 | $\frac{17}{5} \times 60 = 204$ | 17 | 144 |
| 10 | 87 | 100 | 13 | $\frac{13}{10-5} \times 60 = 156$ | 30 | 96 |
| 15 | 90 | 100 | 10 | $\frac{10}{15-10} \times 60 = 120$ | 40 | 60 |
| 25 | 85 | 100 | 15 | 90 | 55 | 30 |
| 45 | 78 | 100 | 22 | 66 | 77 | 6 |
| 60 | 85 | 100 | 15 | $60 = f_c$ | 92 | 0 |
| 75 | 85 | 100 | 15 | 60 | 107 | 0 |
| 90 | 85 | 100 | 15 | 60 | 122 | 0 |
| 110 | 80 | 100 | 20 | 60 | 142 | 0 |
| 130 | 80 | 100 | 20 | 60 | 162 | 0 |

(i) (a) Plot on natural graph paper, t vs. f , Fig. 3.11(a)

Horton's equation $f = f_c + (f_0 - f_c) e^{-kt}$

$$f_0 = 300 \text{ mm/hr}, f_c = 60 \text{ mm/hr}$$

$F_c =$ shaded area

$$= 6 \text{ sq. units} \times \frac{50 \text{ min}}{60 \text{ min}} \times 10 \text{ min}$$

$$= 50 \text{ mm}$$

$$\text{Horton's constant } k = \frac{f_0 - f_c}{F_c} = \frac{300 - 60}{50}$$

$$= 4.8 \text{ hr}^{-1}$$

\therefore

$$f = 60 + \frac{240}{e^{4.8t}}$$

where f is in mm/hr, t in hr.

(b) Plot on semi-log paper 't vs. log (f - f_c)', Fig. (3.11 b).

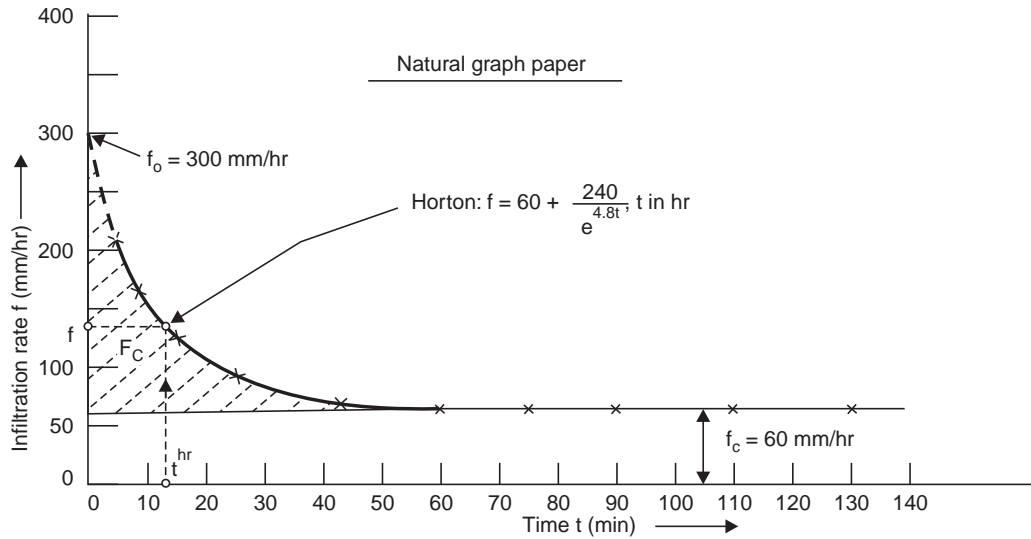

Fig. 3.11 (a) Horton's infiltration curve

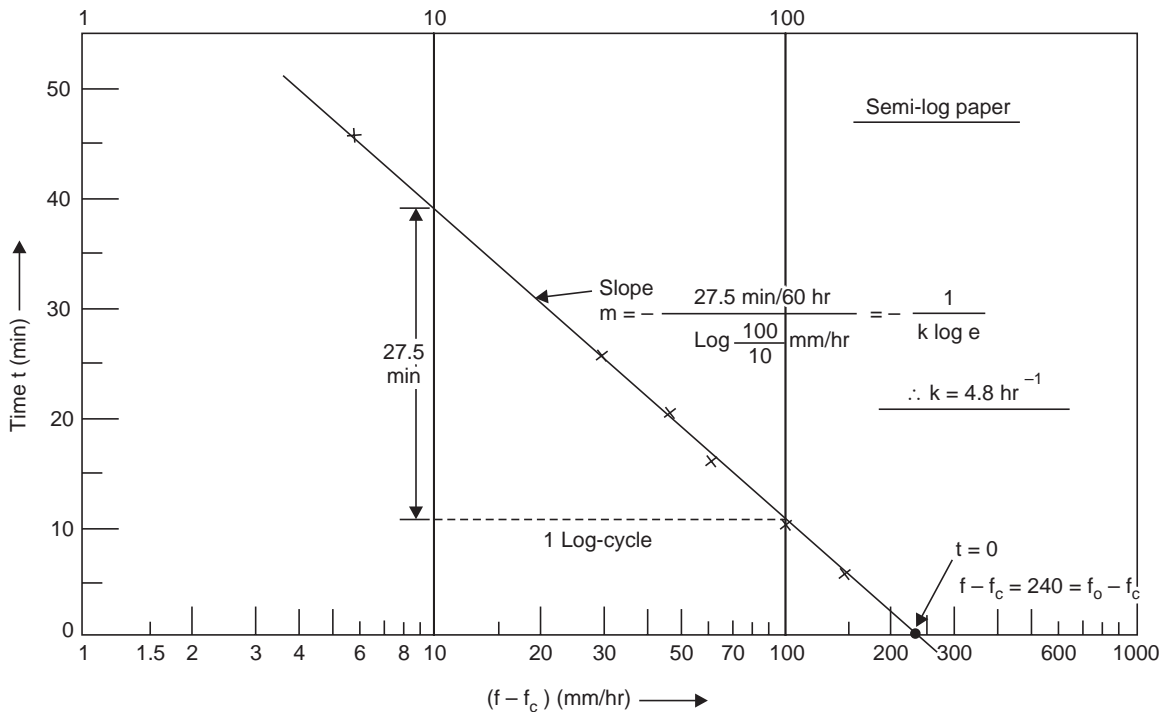

Fig. 3.11 (b) Horton's infiltration constants (k, f₀)

$$f = f_c + (f_0 - f_c)e^{-kt}$$

$$\log (f - f_c) = \log (f_0 - f_c) - kt \log e$$

$$\therefore t = \frac{\log(f_0 - f_c)}{k \log e} - \frac{\log(f - f_c)}{k \log e}$$

i.e., of the form, $y = c + mx$

$$\text{Slope } m = -\frac{1}{k \log e} = -\frac{27.5/60}{1} \quad \therefore k = 4.8 \text{ hr}^{-1}$$

at $t = 0, f - f_c = 240 = f_0 - f_c$

$$\therefore f_0 = 240 + 60 = 300 \text{ mm/hr}$$

$$\therefore \boxed{f = 60 + \frac{240}{e^{4.8t}}}$$

(ii) **Cumulative infiltration curve**

(a) $F = at^n$, kostiakov

Plot ' t vs. F^n ' on log-log paper, Fig. 3.11 (c).

$$\log F = \log a + n \log t$$

i.e.,

$y = c + mx$ form, yields a straight line,

when

$$t = 1, a = F = 5.8$$

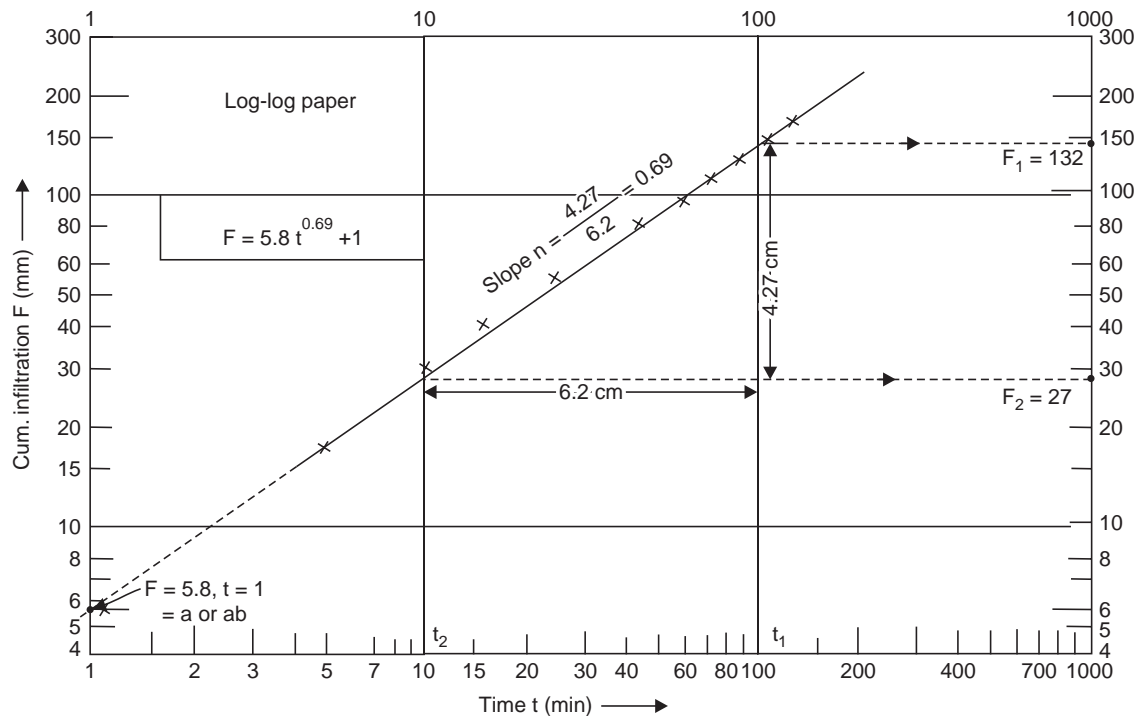

Fig. 3.11(c) Cumulative infiltration plot

also,

$$\log \frac{F_1}{F_2} = n \log \frac{t_1}{t_2}$$

$$\therefore \frac{F_1}{F_2} = \left(\frac{t_1}{t_2}\right)^n$$

$$\frac{132}{27} = \left(\frac{100}{10}\right)^n$$

$\therefore n = 0.69$, also from the plot, Fig. 3.11 (c)

$$\therefore \boxed{F = 5.8 t^{0.69}}$$

$$f = \frac{dF}{dt} = 5.8 \times 0.69 t^{-0.31}$$

i.e.,

$$\boxed{f = \frac{4}{t^{0.31}}}$$

$$(b) \quad F = at^n + b$$

$$\log F = \log ab + n \log t,$$

yields straight line plot, Fig. 3.11 (c)

$$\frac{F_1}{F_2} = \left(\frac{t_1}{t_2}\right)^n$$

$\therefore n = 0.69 =$ slope from the plot

when $t = 1, F = ab = 5.8$, from the plot, Fig. 3.11 (c)

$$\text{Try } b = 1, a = \frac{5.8}{1} = 5.8$$

$$\therefore \boxed{F = 5.8 t^{0.69} + 1}$$

say $t = 25$ min, $F = 5.8 (25)^{0.69} + 1 = \mathbf{55 \text{ mm}}$

also $f = \frac{dF}{dt} = 5.8 \times 0.69 t^{-0.32}$

i.e., $\boxed{f = \frac{4}{t^{0.31}}}$, at $t = 25$ min, $f = 1.48$ mm/min or $\mathbf{86 \text{ mm/hr}}$

which are very near the observed values; otherwise a second trial value of b is necessary.

3.10 INFILTRATION INDICES

The infiltration curve expresses the rate of infiltration (cm/hr) as a function of time. The area between the rainfall graph and the infiltration curve represents the rainfall excess, while the area under the infiltration curve gives the loss of rainfall due to infiltration. The rate of loss is greatest in the early part of the storm, but it may be rather uniform particularly with wet soil conditions from antecedent rainfall.

Estimates of runoff volume from large areas are sometimes made by the use of infiltration indices, which assume a constant average infiltration rate during a storm, although in actual practice the infiltration will be varying with time. This is also due to different states of wetness of the soil after the commencement of the rainfall. There are three types of infiltration indices:

(i) ϕ -index (ii) W -index (iii) f_{ave} -index

(i) ϕ -index—The ϕ -index is defined as that rate of rainfall above which the rainfall volume equals the runoff volume. The ϕ -index is relatively simple and all losses due to infiltration, interception and depression storage (*i.e.*, storage in pits and ponds) are accounted for; hence,

$$\phi\text{-index} = \frac{\text{basin recharge}}{\text{duration of rainfall}} \quad \dots(3.14)$$

provided $i > \phi$ throughout the storm. The bar graph showing the time distribution of rainfall, storm loss and rainfall excess (net rain or storm runoff) is called a *hyetograph*, Fig. 3.12. Thus, the ϕ -index divides the rainfall into net rain and storm loss.

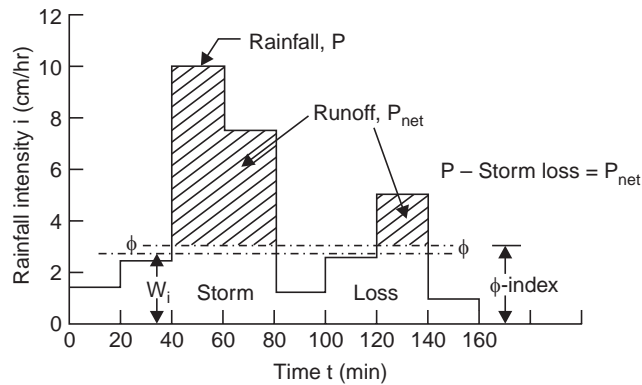

Fig. 3.12 Infiltration loss by ϕ -index

(ii) W -index—The W -index is the average infiltration rate during the time rainfall intensity exceeds the infiltration capacity rate, *i.e.*,

$$W\text{-index} = \frac{F_p}{t_R} = \frac{P - Q - S}{t_R} \quad \dots(3.15)$$

where P = total rainfall

Q = surface runoff

S = effective surface retention

t_R = duration of storm during which $i > f_p$

F_p = total infiltration

The W -index attempts to allow for depression storage, short rainless periods during a storm and eliminates all rain periods during which $i < f_p$. Thus, the W -index is essentially equal to the ϕ -index minus the average rate of retention by interception and depression storage, *i.e.*, $W < \phi$.

Information on infiltration can be used to estimate the runoff coefficient C in computing the surface runoff as a percentage of rainfall *i.e.*,

$$Q = CP \quad \dots(3.16)$$

$$C = \frac{i - W}{i} \quad \dots(3.16 a)$$

(iii) f_{ave} -index—In this method, an average infiltration loss is assumed throughout the storm, for the period $i > f$.

Example 3.6 The rates of rainfall for the successive 30 min period of a 3-hour storm are: 1.6, 3.6, 5.0, 2.8, 2.2, 1.0 cm/hr. The corresponding surface runoff is estimated to be 3.6 cm. Establish the ϕ -index. Also determine the W-index.

Solution Construct the hyetograph as shown in Fig. 3.13 (a)

$$\Sigma(i - \phi)t = P_{\text{net}}, \text{ and thus it follows}$$

$$[(3.6 - \phi) + (5.0 - \phi) + (2.8 - \phi) + (2.2 - \phi)] \frac{30}{60} = 3.6$$

$$\therefore \phi = 1.6 \text{ cm/hr}$$

$$P = (1.6 + 3.6 + 5.0 + 2.8 + 2.2 + 1.0) \frac{30}{60} = 8.1 \text{ cm}$$

$$W\text{-index} = \frac{P - Q}{t_R} = \frac{8.1 - 3.6}{3} = 1.5 \text{ cm/hr}$$

Suppose the same 3-hour storm had a different pattern as shown in Fig. 3.13 (b) producing the same total rainfall of 8.1 cm. To obtain the same runoff of 3.6 cm (shaded area), the ϕ -index can be worked out as 1.82 cm/hr. Hence, it may be seen that a single determination of ϕ -index is of limited value and many such determinations have to be made and averaged, before the index is used. The determination of ϕ -index for a catchment is a trial and error procedure.

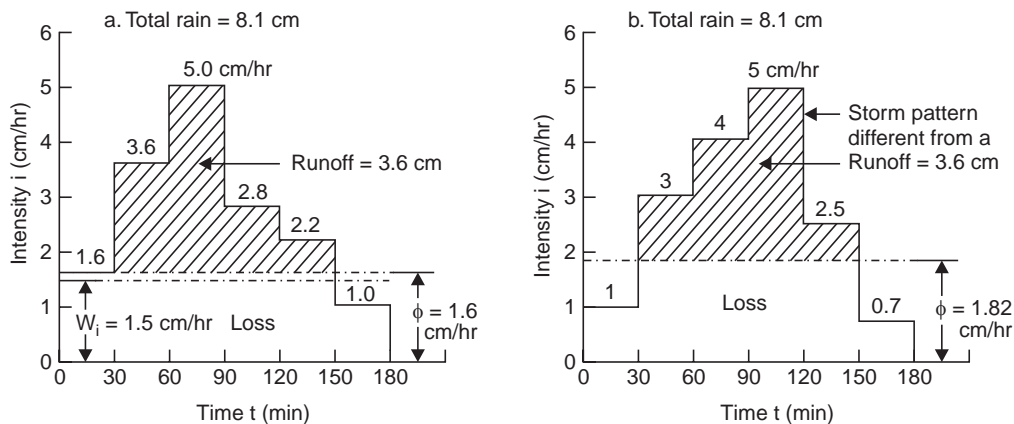

Fig. 3.13 ϕ -Index computations

3.11 SUPRA RAIN TECHNIQUE

Due to complex conditions antecedent and during the rain, and complex catchment characteristics, the use of infiltration method is usually limited to small areas with well-established values of infiltration.

The rainfall in excess of a particular value of ϕ -index for the entire pattern of storm rainfall is called *supra rain*. Allowance for areal variation of rainfall and f -capacity is made by dividing into sub areas in the case of large areas. The mean hourly net rains over the whole catchment can be obtained as

$$P_{\text{net-mean}} = \frac{\Sigma A_1 P_{\text{net-1}}}{\Sigma A_1} \dots(3.17)$$

where A_1, A_2, \dots are the sub-areas.

$$P_{\text{net-1}}, P_{\text{net-2}}, \dots \text{ are the net rains in the sub areas}$$

$$\Sigma A_i = A = \text{total area of the catchment}$$

When a large number of sub-areas are involved the hourly net rains over the whole catchment can be derived by constructing a supra-rain-curve, in which the supra-rain is plotted against hypothetical values of the ϕ -index, Fig. 3.15. The supra-rain-curve thus obtained is valid only for that particular storm from which it is derived. For other storms, new supra rain curves must be prepared. The supra-rain technique is illustrated in the following two examples.

Example 3.7 Hourly rainfalls of 2.5, 6, and 3 cm occur over a 20-ha area consisting 4 ha of $\phi = 5$ cm/hr, 10 ha of $\phi = 3$ cm/hr, and 6 ha of $\phi = 1$ cm/hr. Derive hourly values of net rain.

Solution

| | |
|---------------------------|---|
| 1st hour: (P = 2.5 cm) | $P_{\text{net-mean}} = \frac{4(0) + 10(0) + 6(2.5 - 1)}{20} = \mathbf{0.45 \text{ cm}}$ |
| 2nd hour: (P = 6 cm) | $P_{\text{net-mean}} = \frac{4(6 - 5) + 10(6 - 3) + 6(6 - 1)}{20} = \mathbf{3.20 \text{ cm}}$ |
| 3rd hour: (P = 3 cm) | $P_{\text{net-mean}} = \frac{4(0) + 10(0) + 6(3 - 1)}{20} = \mathbf{0.60 \text{ cm}}$ |

Total net rain for the 3-hour storm = **4.25 cm**

Example 3.8 The successive hourly rains of a 10-hour storm are: 2.5, 6.3, 10, 12, 8, 5, 3, 1.5, 1 cm. Using the supra-rain-curve technique, determine the total net rain and its time distribution for a 20-hr area consisting of 4 ha of $\phi = 5$ cm/hr, 10 ha of $\phi = 3$ cm/hr and 6 ha of $\phi = 1$ cm/hr.

Solution For $\phi = 1$ cm/hr, P_{net} (supra-rain) from the hyetograph—Fig. 3.14 is 41 cm. Similarly, for $\phi = 0.5, 2, 3, 4, 5, 6, 7, 8, 9$ and 10 cm, P_{net} (supra-rain) values are 47, 33.5, 26, 21, 16, 12, 9, 6, 4 and 2 cm, respectively. With these values, the supra-rain-curve is plotted as shown in Fig. 3.15. The supra-rain for the 20-ha area can be obtained by weighing for the sub-areas as follows:

| Sub-area A_i (ha) | ϕ -index (cm/hr) | Sub-areal supra-rain $P_{\text{net-}i}$ (cm) | A_i/A (decimal) | Product (3) \times (4) (cm) |
|---------------------------|--------------------------|--|------------------------------|----------------------------------|
| 1 | 2 | 3 | 4 | 5 |
| 4 | 5 | 16 | 0.2 | 3.2 |
| 10 | 3 | 26 | 0.5 | 13.0 |
| 6 | 1 | 41 | 0.3 | 12.3 |
| A = 20 ha | | | Total net rain over basin | = 28.5 cm |

Corresponding to this supra-rain of 28.5 cm, the mean effective ϕ -index for the entire 20 ha, from Fig. 3.15, is 2.6 cm/hr. Application of $\phi = 2.6$ cm/hr to the values of hourly rainfalls of the 10-hr storm. Fig. 3.13 gives the values of hourly net rain as 0, 3.4, 0.4, 7.4, 9.4, 5.4, 0.4, 0 and 0 cm, respectively, giving a total of 28.8 cm.

Now, by working as in example 3.7, the hourly net rains are obtained in Table 3.1, which also gives a total net rain of 28.80 cm, though the hourly net rains are slightly different from those obtained from the supra-rain-curve technique. Thus, the supra-rain-curve technique yields somewhat erroneous values for hourly net rains as compared with those derived by applying Eq. (3.17), though the total net rain for a given storm is the same by both techniques. However, this loss in accuracy may be justified by the time saved, especially when a large number of sub-areas are involved.

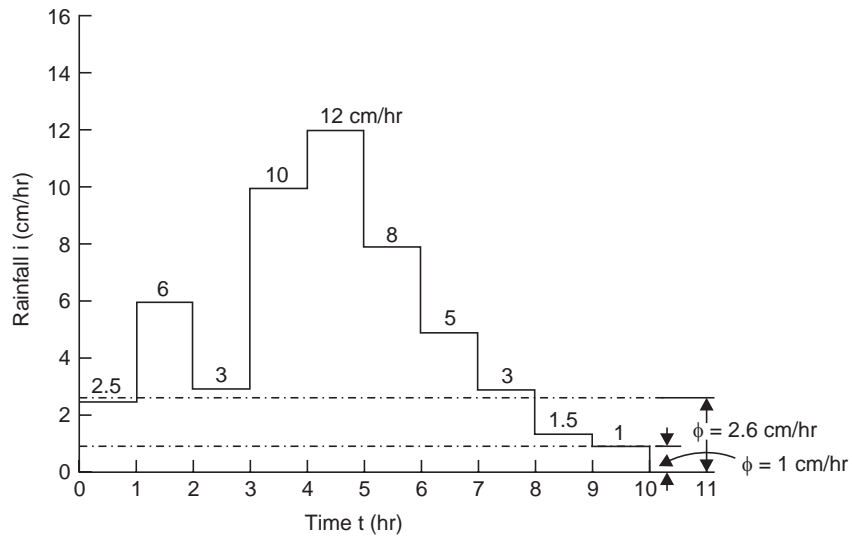

Fig. 3.14 Hyetograph (Example 3.8)

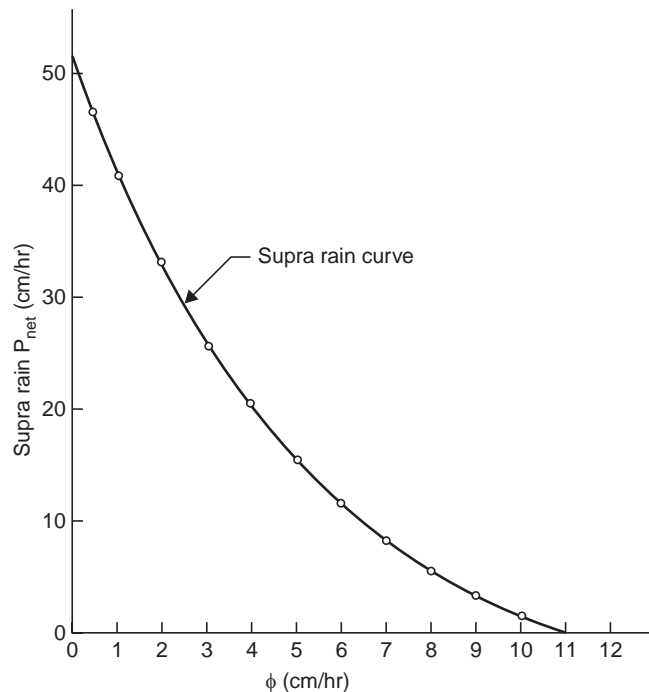

Fig. 3.15 Supra Rain Curve (Example 3.8)

Table 3.1 Net rain from sub-areas with ϕ -values, Example 3.8

| Hour | Rainfall (cm) | Rainfall excess, P_{net} , from sub-areas | | | Weighted P_{net} from sub-areas | | | P_{net} over a basin (cm) |
|-----------------------------|------------------|---|---------------------------|---------------------------|-----------------------------------|--------------------------|--------------------------|--------------------------------|
| | | A_1 $\phi = 5$ cm/hr | A_2 $\phi = 3$ cm/hr | A_3 $\phi = 1$ cm/hr | $(3) \times 0.2$ (cm) | $(4) \times 0.5$ (cm) | $(5) \times 0.3$ (cm) | |
| 1 | 2 | 3 | 4 | 5 | 6 | 7 | 8 | 9 |
| 1 | 2.5 | — | — | 1.5 | — | — | 0.45 | 0.45 |
| 2 | 6 | 1 | 3 | 5 | 0.2 | 1.5 | 1.50 | 3.20 |
| 3 | 3 | — | — | 2 | — | — | 0.6 | 0.60 |
| 4 | 10 | 5 | 7 | 9 | 1.0 | 3.5 | 2.7 | 7.20 |
| 5 | 12 | 7 | 9 | 11 | 1.4 | 4.5 | 3.3 | 9.20 |
| 6 | 8 | 3 | 5 | 7 | 0.6 | 2.5 | 2.1 | 5.20 |
| 7 | 5 | — | 2 | 4 | — | 1.0 | 1.2 | 2.20 |
| 8 | 3 | — | — | 2 | — | — | 0.6 | 0.60 |
| 9 | 1.5 | — | — | 0.5 | — | — | 0.15 | 0.15 |
| 10 | 1 | — | — | — | — | — | — | 0 |
| Total net rain over basin = | | | | | | | | 28.80 cm |

3.12 WATERSHED LEAKAGE

The rain water after infiltrating into the ground may percolate through the subsoil and build up the ground water table (GWT). This ground water through the water bearing strata may flow into the adjacent basin or directly into the sea if the water bearing strata outcrops into the sea. This is called *watershed leakage*. There may be even accretion of ground water into the basin from another nearby or remote basin if there is hydraulic interconnection through a water bearing strata. It is this subsurface, inflow or outflow that poses problem in the water balance studies of the basin.

3.13 WATER BALANCE

The input items into a basin are essentially precipitation (P) and subsurface inflow (G_i) while the water losses are evaporation (E), evapotranspiration (E_t) and subsurface outflow (G_o). The balance goes to recharge ground water (G_r), increase the soil moisture (SMA) and as surface runoff (streamflow, R).

The water balance equation can be written as

$$P + G_i = E + E_t + G_o + SMA + G_r + R$$

A case history of the water balance studies of the Krishna River basin, south India, is as follows:

Water Balance Study of Krishna River Basin

The Krishna river Basin lies between the latitudes 13° 0' N and 19° 30' N and longitudes 73°23' E and 80°30' E, with a drainage area of 258948 km² and total length 1400 km in south India. The hydrometeorological studies and water balance of the basin was made by Subramanyam *et al.* (1980) employing the book keeping technique of Thornthwaite. 60 Stations were used for studying the rainfall patterns of the basin both on an annual basis and in different seasons. Estimation of the water losses from the basin by evapotranspiration was made by using Thornthwaite's formula* for 21 stations in the basin for which the temperature data were available. The monthly normal water balance for the whole year for the Krishna River basin is given in Table 3.2, prepared by using the water balances of individual stations representative of the different sections of the basin (Fig. 3.16).

The water balance study shows that the water need (1375 mm) is higher than the water supply by precipitation (1134 mm), though an amount of 182 mm of water is recorded as rainfall excess (stream flow plus ground water storage (in underground formations)), on account of concentration of rainfall from June to October compared to the lower values of water need during these months.

*Thornthwaite formula: $E_{pt} = ct^a$, mm/month, where t = mean monthly temperature, °C; c , a are constants depending upon the climatic conditions of the area, latitude and the month, for specific crops.

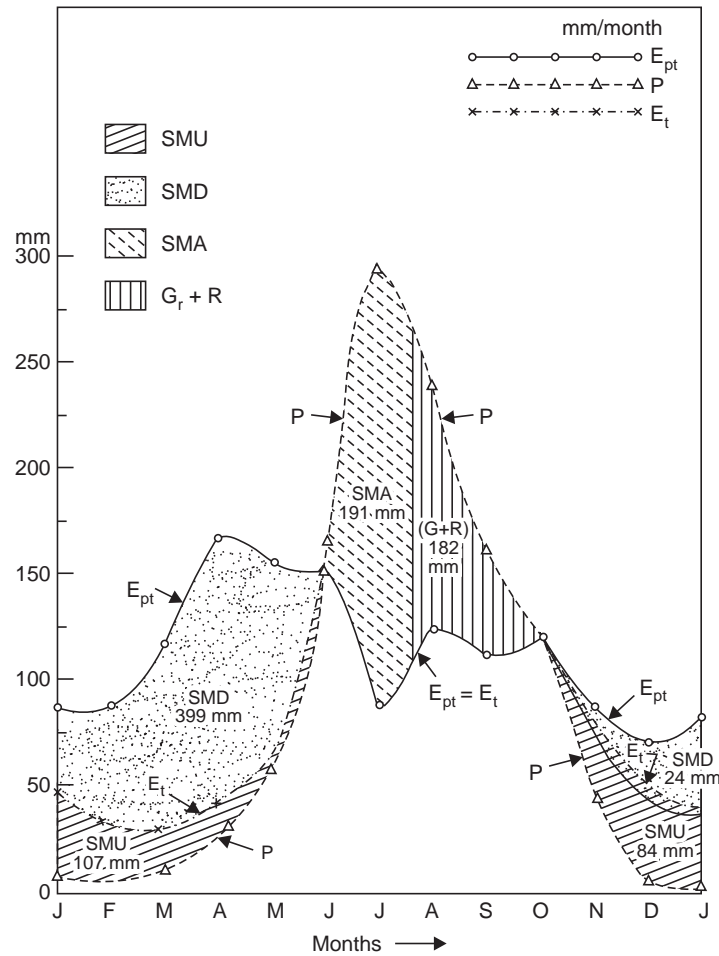

Fig. 3.16 Water balance of Krishna river basin (after Subramanyam *et al.* 1980)

Water deficiency (SMD) obtained from the water balance studies indicates the amount of water needed for supplemental irrigations in agricultural operations, adjustment of crop calendar (so that harvest will precede drought) and crop rotation to improve the soil structure and increase the soil moisture storage capacity. Crop yields can increase if the moisture deficiency could be avoided.

Table 3.2 Water balance for Krishna river basin (Fig. 3.16)

| Month | E_{pt} (mm) | P (mm) | E_t (mm) | SMU $= E_t - P$ (mm) | SMD $= E_{pt} - E_t$ (mm) | SMA $= P - E_{pt} - (R + G_r)$ (mm) | $R + G_r$ (mm) |
|-------|------------------|-------------|---------------|------------------------------|-----------------------------------|---|-------------------|
| Jan | 86 | 6 | 45 | 39 | 41 | — | — |
| Feb | 88 | 4 | 31 | 27 | 57 | — | — |
| Mar | 118 | 9 | 30 | 21 | 88 | — | — |

Contd.

| | | | | | | | |
|-------|------|------|-----|-----|-----|-----|-----|
| April | 167 | 32 | 46 | 14 | 121 | — | — |
| May | 155 | 57 | 63 | 6 | 92 | — | — |
| June | 152 | 165 | 152 | — | — | 13 | — |
| July | 90 | 294 | 90 | — | — | 178 | 26 |
| Aug | 125 | 233 | 125 | — | — | — | 108 |
| Sept | 114 | 159 | 114 | — | — | — | 45 |
| Oct | 120 | 123 | 120 | — | — | — | 3 |
| Nov | 88 | 45 | 84 | 39 | 4 | — | — |
| Dec | 72 | 7 | 52 | 45 | 20 | — | — |
| Total | 1375 | 1134 | 952 | 191 | 423 | 191 | 182 |

Note: E_{pt} = potential evapotranspiration when there is unlimited water in the root zone, *i.e.*, $P \geq E_{pt}$.

P = precipitation (mm/month)

E_t = actual evapotranspiration (mm/month) limited to the availability of water by precipitation and soil moisture stored; $E_t \leq E_{pt}$

SMU = Soil moisture utilisation (mm/month) from storage

SMD = Soil moisture deficit (mm/month) = $E_{pt} - E_t$

SMA = Soil moisture accretion (mm/month) when $P > E_{pt}$

$R + G_r$ = Rainfall excess (stream flow + Ground water accretion) (mm/month)

= $P - E_{pt} - \text{SMA}$; after soil recharge = $P - E_{pt}$

QUIZ III

I Choose the correct statement/s in the following:

- 1 The various water losses are
 - (i) the subsurface outflow from the basin
 - (ii) evaporation from ground water (when the GWT is very near the ground surface)
 - (iii) soil evaporation
 - (iv) interception by plant leaves and buildings
 - (v) evaporation from soil and transpiration from plant leaves in an irrigated land
 - (vi) all the above
- 2 Interception loss is
 - (i) more towards the end of a storm
 - (ii) more at the beginning of a storm
 - (iii) uniform throughout the storm
 - (iv) high in the beginning of storm and gradually decreases
- 3 Evaporation from water surface
 - (i) is proportional to the deficit of vapour pressure
 - (ii) increases with temperature
 - (iii) increases with humidity

- (iv) increases with the exposed area
- (v) increases if there is salinity or pollution
- (vi) decreases with wind velocity
- (vii) increases when a film of acetyl alcohol is spread over the surface
- (viii) is high in arid region

4 Evapotranspiration depends upon

- (i) hours of bright sunshine
- (ii) wind speed
- (iii) temperature
- (iv) humidity
- (v) type of crop
- (vi) season of crop
- (vii) stage of growth for a given crop
- (viii) moisture level in the soil
- (ix) method of irrigation
- (x) all the above factors

5 Infiltration occurs at capacity rate

- (i) if there had been antecedent rainfall
 - (ii) if the intensity of rainfall is lower than the capacity rate
 - (iii) if the intensity of rainfall is higher than the capacity rate
 - (iv) if the rainfall intensity is equal to the capacity rate
 - (v) during a first flash storm following summer
 - (vi) due to watershed leakage
- (1. except i; 2. ii, iv, 3. i, ii, iv, viii; 4. x; 5. iii, iv, v)

II Match items in 'A' with items in 'B' (more than one item in B may fit)

| A | B |
|-------------------------------|---|
| (i) Evaporation | (a) Irrigated Land |
| (ii) Infiltration rate | (b) Plant leaves |
| (iii) Evaporation opportunity | (c) Humid day |
| (iv) Low evaporation | (d) ϕ -index |
| (v) Evapotranspiration | (e) Soil evaporation |
| (vi) Transpiration | (f) Rate of entry of rain water into soil |
| | (g) Dalton's law |
| | (h) Land pan |
| | (i) Float pan |
| | (j) Blaney-Criddle formula |

III Say 'true' or 'false'; if false, give the correct statement:

- (i) Land pan can be placed directly over the land, in the vicinity of a lake or reservoir, to measure pan evaporation.
- (ii) Evaporation is significant in arid regions, while transpiration is significant in humid regions.
- (iii) Evaporation is less on a humid day.
- (iv) Evapotranspiration is often used synonymously with the consumptive use.
- (v) Potential evapotranspiration is the evapotranspiration from a cropped land under limited water supply to the roots.
- (vi) Measurement of transpiration losses can only be made on small laboratory samples.
- (vii) The value of ϕ -index depends only on the soil and is independent of the storm pattern.

- (viii) For the same storm of the same duration, total rain and runoff (net rain), there may be different ϕ -indices for the different storm patterns (*i.e.*, for different time distribution of rain-fall).
- (ix) Supra-rain-curve technique yields exact values for hourly and total net rains.
- (false: *i, v, vii, ix*)

QUESTIONS

- 1 (a) Explain briefly the evaporation process. What are the factors that influence the process of evaporation ?
 (b) Suggest a method of estimating evaporation from a storage reservoir.
 (c) Recommend measures to reduce reservoir evaporation.
- 2 (a) Evaporation is less on a humid day; why ?
 (b) The following were the monthly evaporation data in cm in certain year (Jan.-Dec.) in the vicinity of a lake:

| | | | | | |
|------|------|------|------|------|------|
| 15.7 | 14.1 | 16.9 | 24.0 | 27.5 | 21.4 |
| 15.7 | 16.2 | 16.2 | 20.5 | 15.7 | 15.4 |

The water spread area in the lake in the beginning of January was 3.2 km² and at the end of December 2.6 km². Calculate the loss of water in million m³ due to evaporation in that year. Assume a pan coefficient of 0.71.
- 3 (a) Explain the difference among: evaporation, transpiration and evapotranspiration. Bring out their significance (to a more or less degree) (*i*) in arid region, and (*ii*) in humid region.
 (b) Is evapotranspiration same as consumptive use? What are the factors, which affect evapotranspiration ?
- 4 (a) Can evapotranspiration be estimated from pan evaporation data? Explain.
 (b) For a particular place in the month of November, the percentage sunshine hours is 7.2 and the mean temperature is 18°C. If the consumptive use coefficient for the crop is 0.7 for that month, find the consumptive use of the crop in mm/day. (2.76 mm/day)
- 5 (a) Explain any one method of determining the evapotranspiration of a crop. Is it constant for the entire crop season of that crop? If not, why?
 (b) Determine the consumptive use of wheat in the month of December if the pan evaporation for the month is 8.5 cm. Assume the growing season from November to February and consumptive use coefficient at 40% stage growth as 0.52. (1.47 mm/day)
- 6 (a) Enumerate the various water losses.
 (b) What are the factors, which affect infiltration? Explain any one method of determining the infiltration capacity of a soil surface.
- 7 (a) Sketch a typical curve of infiltration and give its equation. Explain with a neat sketch how you can get such a curve for a portion of area of a river basin.
 (b) A basin has 1/3 portion rocky, 1/3 portion cultivated and 1/3 portion fallow land. How do you proceed to determine the net rain (excess rain) for the entire basin?
- 8 For a given basin, the following are the infiltration capacity rates at various time intervals after the beginning of the storm. Make a plot of the *f*-curve and establish an equation of the form developed by Horton for infiltration curve. Also determine the total rain and the excess rain (runoff).

| <i>Time (min)</i> | <i>Precipitation (cm/hr)</i> | <i>Infiltration capacity (cm/hr)</i> |
|-----------------------|----------------------------------|--|
| 1 | 5.0 | 4.3 |
| 2 | 5.0 | 3.9 |
| 3 | 5.0 | 3.5 |
| 4 | 5.0 | 3.2 |
| 5 | 6.5 | 3.0 |
| 6 | 7.5 | 2.8 |
| 8 | 7.5 | 2.4 |
| 10 | 7.5 | 2.2 |
| 12 | 7.5 | 2.1 |
| 14 | 7.5 | 2.0 |
| 16 | 2.5 | 1.9 |
| 18 | 2.5 | 1.85 |
| 20 | 2.5 | 1.8 |
| 22 | 2.5 | 1.8 |

- 9 (a) What are the methods available to measure infiltration ?
- (b) For a drainage basin having a number of recording raingauges, the precipitation record for each station and the total runoff from the basin are available for a series of major and minor storms. Describe clearly how you would determine the minimum infiltration index for the basin.
- 10 The infiltration capacity of an area at different intervals of time is given below. Find an equation for the infiltration capacity curve in the exponential form:
- | | | | | | | | | | |
|--|------|------|-----|------|------|------|------|------|------|
| <i>Time: (hr)</i> | 0 | 0.25 | 0.5 | 0.75 | 1.00 | 1.25 | 1.50 | 1.75 | 2.00 |
| <i>Infiltration capacit: (cm/hr)</i> | 10.4 | 5.6 | 3.2 | 2.1 | 1.5 | 1.2 | 1.1 | 1.0 | 1.0 |
- 11 (a) Give the correct statement:
- Infiltration is at capacity rates when the rainfall intensity
- (i) is less than the infiltration rate of the soil.
- (ii) is more than the infiltration capacity of the soil.
- (b) Differentiate between : infiltration rate and infiltration capacity.
- (c) The rate of rainfall for the successive 30 min period of a 3-hour storm are: 1.6, 3.6, 5.0, 2.8, 2.2, 1.0 cm/hr. The corresponding surface runoff is estimated to be 3.6 cm. Establish the ϕ -index. Also determine the W -index.
- 12 The rates of rainfall for successive 30 min period of 210 min storm are: 3.5, 4.0, 12.0, 8.5, 4.5, 4.5 and 3.0 cm/hr. Assuming the ϕ -index of 3.5 cm/hr, find out the net rainfall in cm, the total rainfall and the value of W -index. (8 cm, 20 cm, 3.43 cm/hr)
- 13 The average rainfall over 45 ha of watershed for a particular storm was as follows:
- | | | | | | | | | |
|----------------|---|-----|-----|------|-----|-----|-----|---|
| Time (hr): | 0 | 1 | 2 | 3 | 4 | 5 | 6 | 7 |
| Rainfall (cm): | 0 | 0.5 | 1.0 | 3.25 | 2.5 | 1.5 | 0.5 | 0 |

The volume of runoff from this storm was determined as 2.25 ha-m. Establish the ϕ -index.
(0.81 cm/hr)

- 14 An infiltration capacity curve prepared for a catchment indicated an initial infiltration capacity of 2.5 cm/hr and attains a constant value of 0.5 cm/hr after 10 hours of rainfall with the Horton's constant $k = 6 \text{ day}^{-1}$. Determine the total infiltration loss.
- 15 Determine the runoff from a catchment of area 1.8 km² over which 8 cm of rainfall occurred during 1-day storm. An infiltration capacity curve prepared indicated an initial infiltration capacity of 10 mm/hr and attained a constant value of 3 mm/hr after 16 hours of rainfall, with the Horton's constant $k = 5 \text{ hr}^{-1}$. A floating pan installed in the catchment indicated a decrease of 6 mm in water level on that day.
- 16 Successive hourly rainfalls of 1.5, 5 and 3 cm occur over a 25 ha area consisting of 5 ha of $\phi = 4 \text{ cm/hr}$, 12 ha of $\phi = 3 \text{ cm/hr}$ and 8 ha of $\phi = 1 \text{ cm/hr}$. Derive the net rain in the successive hours.
(0.16, 2.44, 0.64 cm)
- 17 A 3-hour storm occurs over a 60 km² area. From the following data, determine the net storm rain for the whole area and its hourly distribution.

| Sub-area (km ²) | ϕ -index (cm/hr) | Hourly rain (cm) | | |
|--------------------------------|--------------------------|------------------|--------|--------|
| | | 1st hr | 2nd hr | 3rd hr |
| 15 | 2.0 | 1.5 | 5.0 | 1.0 |
| 20 | 3.2 | 1.5 | 5.0 | 1.0 |
| 25 | 1.2 | 1.6 | 5.5 | 1.5 |

(3.436 cm ; 0.17, 3.141, 0.125 cm)

- 18 The successive hourly rains of a 8-hour storm are: 1.5, 5, 2.6, 8, 10, 6, 3, 1 cm. Using the supra-rain-curve technique, determine the net rain in successive hours and the total rain for a 30 ha area consisting of 6 ha of $\phi = 3 \text{ cm/hr}$, 16 ha of $\phi = 2 \text{ cm/hr}$ and 8 ha of $\phi = 1 \text{ cm/hr}$.
- 19 Write short notes on:
 - (i) Pan coefficient
 - (ii) ϕ -index
 - (iii) Evaporation opportunity
 - (iv) Supra rain
 - (v) Lysimeters
 - (vi) Phytometers
 - (vii) Soil evaporation
 - (viii) Water shed leakage
 - (ix) Dalton's law of evaporation
- 20 Distinguish between
 - (i) ϕ -index and W -index
 - (ii) Land pan and Infiltrometer
 - (iii) Infiltration capacity and Infiltration rate
 - (iv) Evaporation and Transpiration
 - (v) Phytometer and Lysimeter
- 21 The following are the data obtained in an infiltration test.
 - (i) Make a plot of f -curve and establish an equation of the form developed by Horton.
 - (ii) Plot the cumulative infiltration curve (*i.e.*, cumulative infiltration F_p vs. time t) and obtain its equation of the form $F_p = at^\alpha + b$, where a , b and α are constant.

[Hint Plot F_p (cm) vs. t (min), with t on x -axis, on log-log paper]

Double Ring Infiltrometer Tests Results

| Elapsed time (min) | Reading to water surface | |
|-----------------------|--------------------------|-----------------------|
| | Before filling (cm) | After filling (cm) |
| 0 | — | 10 |
| 5 | 8.3 | 10 |
| 10 | 8.7 | 10 |
| 15 | 9.0 | 10 |
| 25 | 8.5 | 10 |
| 45 | 7.8 | 10 |
| 60 | 8.5 | 10 |
| 75 | 8.5 | 10 |
| 90 | 8.5 | 10 |
| 110 | 8.0 | 10 |
| 130 | 8.0 | 10 |

$$\left(\text{Ans. } f_{cm/hr} = 6 + \frac{24}{\exp(6t_{hr})}, F_p = 0.57 t^{0.7} + 0.6 \right)$$

- 22 The following are the data for the first crop of rise (kuruvai) in the Cauvery delta at Thanjavur, south India.

Growing season: June 16 to Oct. 15

| Month | Mean temp. (°C) | Sunshine hours (%) | Consumptive use coefficient | Effective rainfall (cm) |
|-------|--------------------|-----------------------|-----------------------------|----------------------------|
| June | 31.0 | 8.60 | 1.15 | 9.2 |
| July | 30.8 | 8.82 | 1.30 | 10.2 |
| Aug. | 30.0 | 8.75 | 1.25 | 11.4 |
| Sept. | 29.5 | 8.26 | 1.10 | 9.4 |
| Oct. | 28.1 | 8.33 | 0.90 | 3.5 |

- Determine: (a) peak consumptive use in mm/day
 (b) seasonal consumptive use
 (c) the total irrigation requirement assuming an irrigation efficiency of 70%

(Ans. 8.25 mm, 88.2 cm, 72.6 cm)

- 23 Hourly rainfalls of three storms given below yield runoff of 14, 23 and 18.5 mm, respectively. Determine the ϕ -index for the catchment:

| | | | | | | | |
|--------------|---|---|----|----|----|---|----------|
| Hour | 1 | 2 | 3 | 4 | 5 | 6 | |
| Storm-1 (mm) | 3 | 8 | 11 | 4 | 12 | 3 | |
| Storm-2 (mm) | 4 | 9 | 15 | 12 | 5 | | |
| Storm-3 (mm) | 2 | 6 | 7 | 10 | 5 | 4 | [4.1 mm] |

24. A constant water level of 110 mm is maintained in an infiltration ring test by adding water frequently as it drops down as:

| | | | | | | | | | | | |
|----------------------------|-----|----|-----|-----|----|----|----|----|----|-----|-----|
| Time (min) since start: | 0 | 5 | 10 | 15 | 25 | 45 | 60 | 75 | 90 | 110 | 130 |
| Water level: (mm) | 110 | 93 | 100 | 101 | 95 | 88 | 95 | 95 | 95 | 90 | 90 |

Develop an infiltration equation of the Horton's type. Draw the infiltration capacity and cumulative infiltration curves. $[f = 60 + 180 e^{-5t}, \text{ mm/hr}]$

25. A $1\frac{1}{2}$ hr storm of intensity 25 mm/hr occurs over a basin for which the Horton's equation is established as $f = 6 + 16 e^{-2t}$. Determine the depth of infiltration in the first 45 min and the average infiltration rate for the first 75 min. Is it the same as W-index ?

(Ans. 10.7 mm, 12 mm/hr; yes $\because i > f$)

Note. $F = \int_0^t f dt, f_{ave} = \frac{F}{t}$; if $i > f$ throughout the duration of storm, $f_{ave} = W_i$.

Chapter 4

RUNOFF

4.1 COMPONENTS OF STREAM FLOW

When a storm occurs, a portion of rainfall infiltrates into the ground and some portion may evaporate. The rest flows as a thin sheet of water over the land surface which is termed as *overland flow*. If there is a relatively impermeable stratum in the subsoil, the infiltrating water moves laterally in the surface soil and joins the stream flow, which is termed as underflow (subsurface flow) or interflow, Fig. 4.1. If there is no impeding layer in the subsoil the infiltrating water percolates into the ground as deep seepage and builds up the ground water table (GWT or phreatic surface). The ground water may also contribute to the stream flow, if the GWT is higher than the water surface level of the stream, creating a hydraulic gradient towards the stream. Low soil permeability favours overland flow. While all the three types of flow contribute to the stream flow, it is the overland flow, which reaches first the stream channel, the interflow being slower reaches after a few hours and the ground water flow being the slowest reaches the stream channel after some days. The term direct runoff is used to include the overland flow and the interflow. If the snow melt contributes to the stream flow it can be included with the direct runoff (from rainfall).

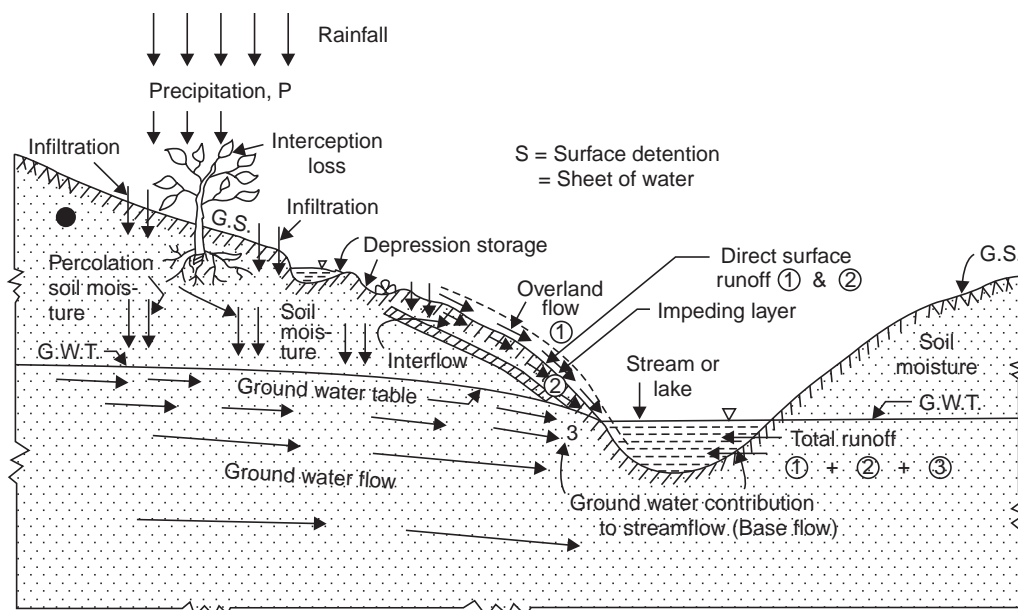

Fig. 4.1 Disposal of rain water

Direct surface flow can be analysed for relatively large drainage areas by the unit hydrograph method and for smaller areas by overland flow analysis. The direct runoff results from the occurrence of an immediately preceding storm while the ground water contribution, which takes days or months to reach the stream, in all probability has no direct relation with the immediately preceding storm. The ground water flow into the stream would have continued even if there had been no storm immediately preceding. It is for this reason it is termed as *base flow* in hydrograph analysis.

When the overland flow starts (due to a storm) some flowing water is held in puddles, pits and small ponds; this water stored is called *depression storage*. The volume of water in transit in the overland flow which has not yet reached the stream channel is called *surface detention* or *detention storage*. The portion of runoff in a rising flood in a stream, which is absorbed by the permeable boundaries of the stream above the normal phreatic surface is called bank storage, Fig. 4.2.

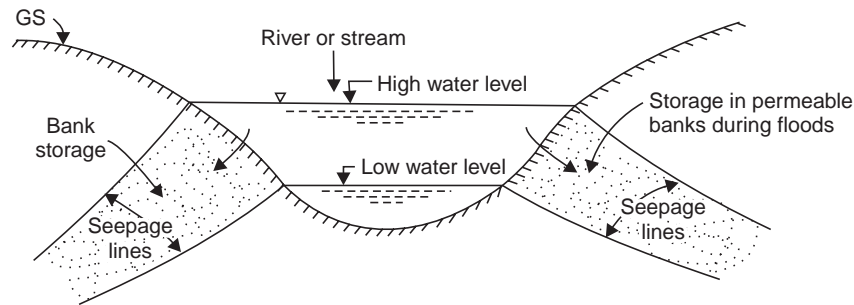

Fig. 4.2 Bank storage

4.2 CATCHMENT CHARACTERISTICS

The entire area of a river basin whose surface runoff (due to a storm) drains into the river in the basin is considered as a hydrologic unit and is called *drainage basin*, watershed or catchment area of the river flowing (Fig. 4.3). The boundary line, along a topographic ridge, separating

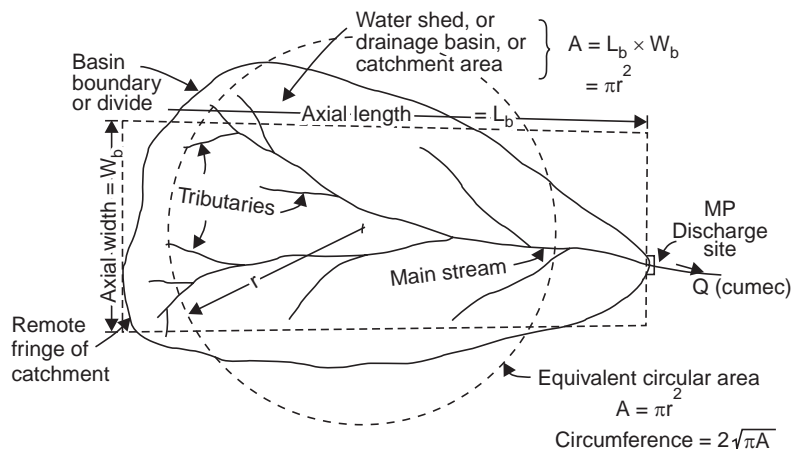

Fig. 4.3 Drainage basin characteristics

two adjacent drainage basins is called *drainage divide*. The single point or location at which all surface drainage from a basin comes together or concentrates as outflow from the basin in the stream channel is called *concentration point* or *measuring point*, since the stream outflow is usually measured at this point. The time required for the rain falling at the most distant point in a drainage area (*i.e.*, on the fringe of the catchment) to reach the concentration point is called the concentration time. This is a very significant variable since only such storms of duration greater than the time of concentration will be able to produce runoff from the entire catchment area and cause high intensity floods.

The characteristics of the drainage net may be physically described by:

- (i) the number of streams
- (ii) the length of streams
- (iii) stream density
- (iv) drainage density

The stream density of a drainage basin is expressed as the number of streams per square kilometre.

$$\text{stream density, } D_s = \frac{N_s}{A} \quad \dots(4.1)$$

where N_s = number of streams
 A = area of the basin

Drainage density is expressed as the total length of all stream channels (perennial and intermittent) per unit area of the basin and serves as an index of the areal channel development of the basin

$$\text{Drainage density, } D_d = \frac{L_s}{A} \quad \dots(4.2)$$

where L_s = total length of all stream channels in the basin.

Drainage density varies inversely as the length of overland flow and indicates the drainage efficiency of the basin. A high value indicates a well-developed network and torrential runoff causing intense floods while a low value indicates moderate runoff and high permeability of the terrain.

$$\text{Average stream slope} = \frac{\text{total fall of the longest water course}}{\text{length of the longest water course}}$$

Horton has suggested a method of determining the slope of large drainage areas, *i.e.*, the area is subdivided into a number of square grids of equal size. The number of contours crossed by each subdividing line is counted and the lengths of the grid lines are scaled. Then the slope of the basin is given by

$$S = \frac{1.5 (CI) N_c}{\Sigma L} \quad \dots(4.3)$$

where S = slope of the basin

CI = contour interval

N_c = number of contours crossed by all the subdividing lines

ΣL = total length of the subdividing lines

The boundary line along a topographic ridge, separating two adjacent drainage basins is called the *drainage divide*. The line of the ground water table from which the water table

slopes downward away from the line on both sides, is called the *ground water divide*. The shape of a drainage basin can generally be expressed by:

(i) form factor (ii) compactness coefficient

Form factor,
$$F_f = \frac{W_b}{L_b} = \frac{A}{L_b^2} \quad \dots(4.4)$$

$$\therefore A = W_b \cdot L_b$$

where W_b = axial width of basin

L_b = axial length of basin, *i.e.*, the distance from the measuring point (MP) to the most remote point on the basin.

Compactness coefficient,
$$C_c = \frac{P_b}{2\sqrt{\pi A}} \quad \dots(4.5)$$

where P_b = perimeter of the basin

$2\sqrt{\pi A}$ = circumference of circular area, which equals the area of the basin.

If R is the radius of an equivalent circular area,

$$A = \pi R^2, \quad R = \sqrt{\frac{A}{\pi}}$$

Circumference of the equivalent circular area = $2\pi R = 2\pi \sqrt{\frac{A}{\pi}} = 2\sqrt{\pi A}$

The compactness coefficient is independent of the the size of the catchment and is dependent only on the slope.

A fan-shaped catchment produces greater flood intensity since all the tributaries are nearly of the same length and hence the time of concentration is nearly the same and is less, whereas in the fern-shaped catchments, the time of concentration is more and the discharge is distributed over a long period (Fig. 4.4).

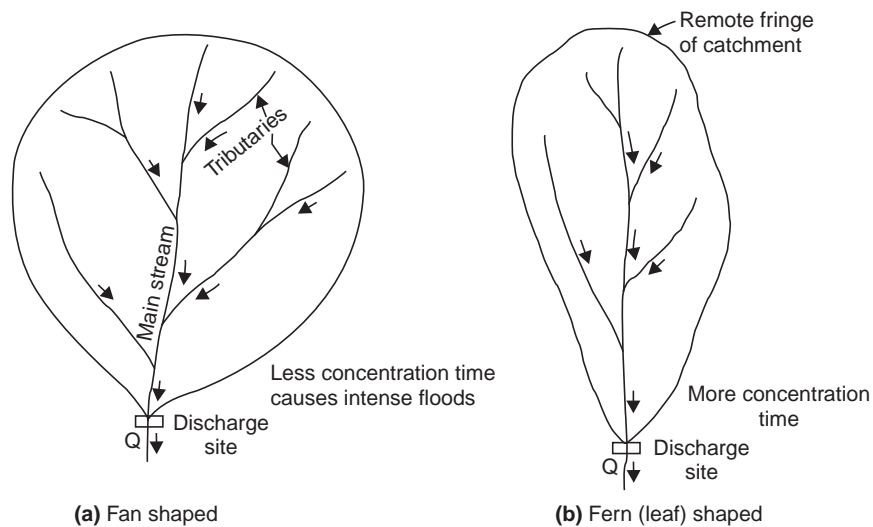

Fig. 4.4 Fan-and fern-shaped catchments

Schumm S.A. (1956) used an 'elongation ratio (E_r)', defined as the ratio of the diameter of a circle of the same area as the basin to the maximum basin length; the values range from 0.4 to 1.0.

Miller V.C. (1953) used a dimensionless 'circularity ratio (C_r)', defined as the ratio of the basin area to the area of a circle having the same perimeter as the basin; the values range from 0.2 to 0.8.

The drainage basin characteristics influence the time lag of the unit hydrograph and peak flow (Taylor and Schwartz, 1952).

Example 4.1 The contour map of a basin is subdivided into a number of square grids of equal size by drawing horizontal and vertical lines as shown in Fig. P4.1. The contour interval is 25 m.

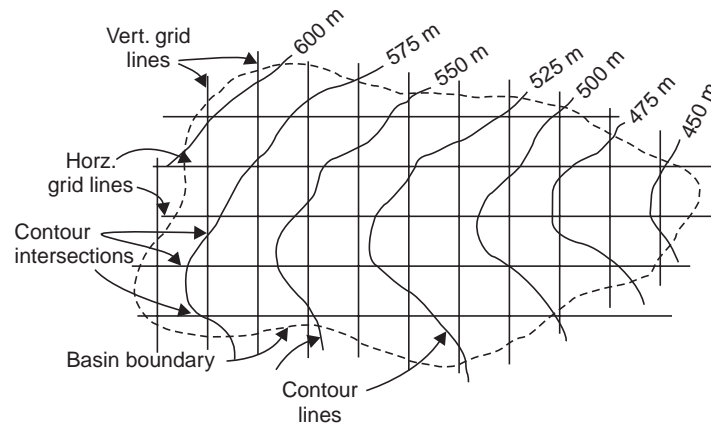

Fig. P4.1 Horton's grid for basin slope

The number of contour intersections by vertical lines is 75 and by horizontal lines 126. The total length of the vertical grid segments (after multiplying by the scale) is 53260 m and of the horizontal grid segments 55250 m. Determine the mean slope of the basin.

Solution Slope in the vertical direction

$$S_v = \frac{N_c \times C.I.}{\Sigma Y} = \frac{75 \times 25}{53260} = 0.0352 \text{ m/m}$$

Slope in the horizontal direction

$$S_x = \frac{N_c \times C.I.}{\Sigma X} = \frac{126 \times 25}{55250} = 0.0570 \text{ m/m}$$

\therefore Mean slope of the basin

$$S = \frac{S_v + S_x}{2} = \frac{0.0352 + 0.0570}{2} = 0.0461 \text{ m/m or } 4.61\%$$

Also, from the Hortons equation,

$$S = \frac{1.5 (C.I) N_c}{\Sigma L} = \frac{1.5 \times 25 (75 + 126)}{(53260 + 55250)} = 0.0695 \text{ or } 6.95\%$$

Example 4.2 A basin has an area of 26560 km², perimeter 965 km and length of the thalweg 230 km. Determine: (i) form factor, (ii) compactness coefficient, (iii) elongation ratio, and (iv) circularity ratio.

Solution (i) Form factor, $F_f = \frac{A}{L_b^2} = \frac{26560}{230^2} = 0.502$

An inverted factor will give **2**

(ii) Compactness Coefficient C_c

Radius R of an equivalent circular area is given by

$$26560 = \pi R^2 \quad \therefore R = 91.9 \text{ km}$$

$$C_c = \frac{P_b}{2\pi R} = \frac{965}{2\pi(91.9)} = 1.67$$

(iii) Elongation ratio $E_r = \frac{2R}{L_b} = \frac{2(91.9)}{230} = 0.8$

(iv) Circularity ratio C_r

Radius R' of a circle of an equivalent perimeter as the basin is given by

$$2\pi R' = 965 \quad \therefore R' = 153.5 \text{ km}$$

$$\therefore C_r = \frac{A}{\pi R'^2} = \frac{26560}{\pi(153.5)^2} = 0.358$$

4.3 MEAN AND MEDIAN ELEVATION

The mean elevation is determined as the weighted average of elevations between two adjacent contours.

The mean elevation of a drainage basin is given by

$$z_b = \frac{\sum a_1 z_1}{\sum a_1} \quad \dots(4.6)$$

where z_b = mean elevation of the drainage basin

a_1, a_2 = areas between the successive contours of the basin

z_1, z_2 = mean elevations between the two successive contours

$\sum a_1 = A =$ area of the basin

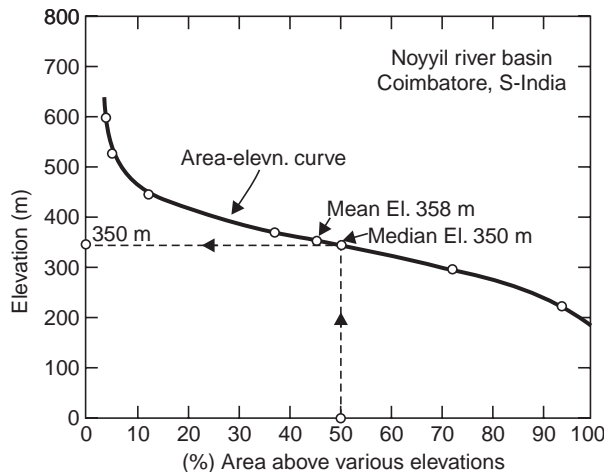

Fig. 4.5 Hypsometric curve (Example 4.2)

The median elevation is the elevation at 50% area of the catchment and is determined from the area-elevation curve. The area elevation curve is obtained by plotting the contour elevation against area or percent of area, above or below that elevation, Fig. 4.5. The area-elevation curve is also called the *hypsothetic curve* for the basin and is illustrated in the following example.

Example 4.3 *The areas between different contour elevations for the Noyyil River basin, Coimbatore (south India) are given below. Determine the mean and the median elevation for the basin.*

| Contour elevations (m) | Area between contours (km ²) |
|---------------------------|---|
| < 225 | 181 |
| 225–300 | 723 |
| 300–375 | 1144 |
| 375–450 | 814 |
| 450–525 | 216 |
| 525–600 | 46 |
| >600 | 140 |

Solution

Table 4.1 Computation of mean elevation of basin.

| Contour elevation (m) | Mean elevation between contours, z_1 (m) | Area between contours, a_1 (km ²) | Product $a_1 z_1$ (2) × (3) (km ² –m) | Mean elevation (m) |
|--------------------------|---|--|---|---|
| 1 | 2 | 3 | 4 | 5 |
| <225 | 200 | 181 | 36200 | $z_b = \frac{\sum a_1 z_1}{\sum a_1}$ $= \frac{1169940}{3264}$ $= \mathbf{358 \text{ m}}$ |
| 225-300 | 262.5 | 723 | 190000 | |
| 300-375 | 337.5 | 1144 | 386000 | |
| 375-450 | 412.5 | 814 | 335500 | |
| 450-525 | 487.5 | 216 | 105400 | |
| 525-600 | 562.5 | 46 | 25840 | |
| >600 | 650 | 140 | 91000 | |
| | | 3264 $= \sum a_1 = A$ | 1169940 $= \sum a_1 z_1$ | |

Table 4.2 Computation of median elevation of basin.

| Contour elevations (m) | Area between contours, a_1 (km ²) | Percentage of total area (%) | % of total area over given lower limit |
|------------------------|---|------------------------------|--|
| <225 | 181 | 5.5 | 100.0 |
| 225-300 | 723 | 22.1 | 94.5 |
| 300-375 | 1144 | 35.1 | 72.4 |
| 375-450 | 814 | 25.0 | 37.3 |
| 450-525 | 216 | 6.6 | 12.3 |
| 525-600 | 46 | 1.4 | 5.7 |
| <600 | 140 | 4.3 | 4.3 |
| A = 3264 | | | |

The hypsometric curve is obtained by plotting the contour elevation (lower limit) against the corresponding percent of total area, Fig. 4.5; the median elevation for 50% of total area is read from the curve as 350 m, while the mean elevation is 358 m (Table 4.1).

4.4 CLASSIFICATION OF STREAMS

Streams may be classified as:

- (i) Influent and Effluent streams
- (ii) Intermittent and perennial streams

(i) *Influent and Effluent streams.* If the GWT is below the bed of the stream, the seepage from the stream feeds the ground-water resulting in the build up of water mound (Fig. 4.6). Such streams are called *influent streams*. Irrigation channels function as influent streams and many rivers which cross desert areas do so. Such streams will dry up completely in rainless period and are called *ephemeral streams*. The ephemeral streams, generally seen in arid regions, which flow only for a few hours after the rainfall, are of no use for conventional hydropower. However, they can occasionally be used in pure pumped storage schemes, where the actual consumption of water is only marginal.

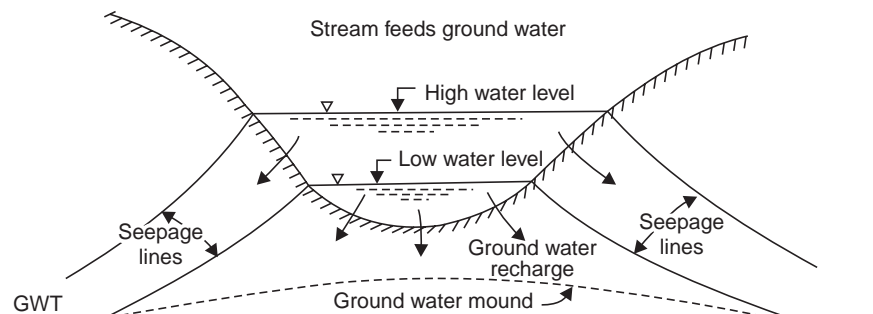

Fig. 4.6 Influent streams

When the GWT is above water surface elevation in the stream, the ground water feeds the stream, Fig. 4.7. Such streams are called *effluent streams*. The base flow of surface streams is the effluent seepage from the drainage basin. Most of the perennial streams are mainly effluent streams.

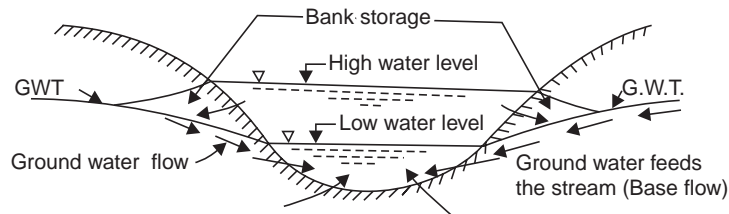

Fig. 4.7 Effluent streams

(ii) *Intermittent and perennial streams*. If the GWT lies above the bed of the stream during the wet season but drops below the bed during the dry season, the stream flows during wet season (due to surface runoff and ground water contribution) but becomes dry during dry seasons. Such streams are called *intermittent streams*.

While in the case of perennial streams, even in the most severe droughts, the GWT never drops below the bed of the stream and therefore they flow throughout the year. For power development a perennial stream is the best; power can also be generated from intermittent streams by providing adequate storage facilities.

4.5 ISOCHRONES

The lines joining all points in a basin of some key time elements in a storm, such as beginning of precipitation, are called isochrones (Fig. 4.8). They are the time contours and represent lines of equal travel time and they are helpful in deriving hydrographs.

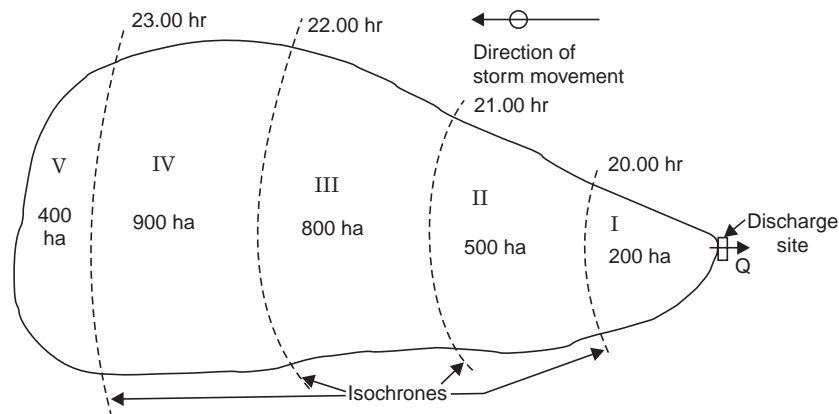

Fig. 4.8 Isochrones

4.6 FACTORS AFFECTING RUNOFF

The various factors, which affect the runoff from a drainage basin depend upon the following characteristics:

| | | |
|-------------------------------------|---|---|
| (i) Storm characteristics | } | Type or nature of storm and season Intensity Duration Areal extent (distribution) Frequency Antecedent precipitation Direction of storm movement |
| (ii) Meteorological characteristics | } | Temperature Humidity Wind velocity, Pressure variation |
| (iii) Basin characteristics | } | Size Shape Slope Altitude (elevation) Topography Geology (type of soil) Land use/vegetation Orientation Type of drainage net Proximity to ocean and mountain ranges |
| (iv) Storage characteristics | } | Depressions Pools and ponds/lakes Stream Channels Check dams (in gullies) Upstream reservoir /or tanks Flood plains, swamps Ground water storage in pervious deposits (aquifers) |

Low intensity storms over longer spells contribute to ground water storage and produce relatively less runoff. A high intensity storm or smaller area covered by it increases the runoff since the losses like infiltration and evaporation are less. If there is a succession of storms, the runoff will increase due to initial wetness of the soil due to antecedent rainfall. Rain during summer season will produce less runoff, while that during winter will produce more.

Greater humidity decreases evaporation. The pressure distribution in the atmosphere helps the movement of storms. Snow storage and specially the frozen ground greatly increase the runoff.

Peak runoff (if expressed as cumec/km²) decreases as the catchment area increases due to higher time of concentration. A fan-shaped catchment produces greater flood intensity than a fern-shaped catchment.

Steep rocky catchments with less vegetation will produce more runoff compared to flat tracts with more vegetations. If the vegetation is thick greater is the absorption of water, so

less runoff. If the direction of the storm producing rain is down the stream receiving the surface flow, it will produce greater flood discharge than when it is up the stream. If the catchment is located on the orographic side (windward side) of the mountains, it receives greater precipitation and hence gives a greater runoff. If it is on the leeward side, it gets less precipitation and so less runoff. Similarly, catchments located at higher altitude will receive more precipitation and yield greater runoff. The land use pattern—arable land, grass land, forest or cultivated area, greatly affect runoff.

The storage in channels and depressions (valley storage) will reduce the flood magnitude. Upstream reservoirs, lakes and tanks will moderate the flood magnitudes due to their storage effects. For drainage basins having previous deposits, large ground water storage may be created, which may also contribute to the stream flow in the form of delayed runoff.

4.7 ESTIMATION OF RUNOFF

Runoff is that balance of rain water, which flows or runs over the natural ground surface after losses by evaporation, interception and infiltration.

The yield of a catchment (usually means annual yield) is the net quantity of water available for storage, after all losses, for the purposes of water resources utilisation and planning, like irrigation, water supply, etc.

Maximum flood discharge. It is the discharge in times of flooding of the catchment area, i.e., when the intensity of rainfall is greatest and the condition of the catchment regarding humidity is also favourable for an appreciable runoff.

Runoff Estimation

The runoff from rainfall may be estimated by the following methods:

- (i) Empirical formulae, curves and tables
- (ii) Infiltration method
- (iii) Rational method
- (iv) Overland flow hydrograph
- (v) Unit hydrograph method
- (vi) Coaxial Graphical Correlation and API (See art. 13.4 and Ex. 13.3 in Chapter 13)

The above methods are discussed as follows :

(i) *Empirical formulae, curves and tables.* Several empirical formulae, curves and tables relating to the rainfall and runoff have been developed as follows:

$$\text{Usually,} \quad R = a P + b \quad \dots(4.7)$$

$$\text{sometimes,} \quad R = a P^n \quad \dots(4.8)$$

where R = runoff, P = rainfall, a , b , and n , are constants. Eq. (4.7) gives a straight line plot on natural graph paper while Eq. (4.8) gives an exponential curve on natural graph paper, Fig. 4.9 *a* and a straight line plot on log-log paper Fig. 4.9 *b*; the constants can be obtained from the straight line plots as shown in Fig. 4.9. Also see Chapter 13, and Ex. 13.4 with Computer Program—C.

For example, C.C. Inglis' formula for Bombay—Deccan catchments (Ghat areas)

$$R = 0.85P + 30.5 \quad \dots(4.9)$$

and for plains

$$R = \frac{(P - 17.8)P}{254} \quad \dots(4.10)$$

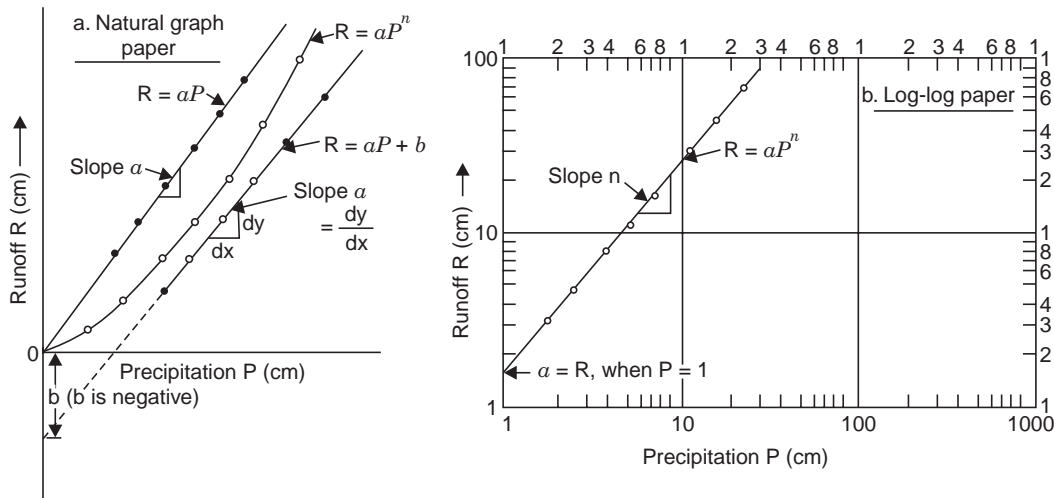

Fig. 4.9 Rainfall-Runoff correlation

Lacey’s formula for Indo-Gangetic plain

$$R = \frac{P}{1 + \frac{304.8}{P} \left(\frac{F}{S} \right)} \quad \dots(4.11)$$

where F is a monsoon duration factor varying between 0.5 to 1.5 and S is the catchment factor depending upon the slope and varies from 0.25 for flat areas to 3.45 for hilly areas

A.N. Khosla’s formula for north India

$$R = P - \frac{T}{3.74} \quad \dots(4.12)$$

Formulae for some of the drainage basins in India:

Ganga basin $R = 2.14 P^{0.64} \quad \dots(4.13)$

Yamuna basin (Delhi) $R = 0.14 P^{1.1} \quad \dots(4.14)$

Rihand basin (U.P.) $R = P - 1.17 P^{0.86} \quad \dots(4.15)$

Chambal basin (Rajasthan) $R = 120P - 4945 \quad \dots(4.16)$

Tawa basin (M.P.) $R = 90.5P - 4800 \quad \dots(4.17)$

Tapti basin (Gujarat) $R = 435P - 17200 \quad \dots(4.18)$

In the above formulae, R is the average annual runoff in cm, P is the average annual rainfall in cm, T is the mean annual temperature in °C for the entire drainage basin.

In addition to the above, several investigators have presented the rainfall-runoff relationships in the form of curves and tables such as

- (a) Binnie’s percentages (tables) for catchments in Madhya Pradesh
- (b) Strange’s curves and tables for Bombay-Deccan catchments
- (c) Barlow’s tables for runoff coefficients in UP

Reference may be made to some of the Indian irrigation text-books, for the details and utility of the above curves and tables.

The yield of a catchment can be simply worked out by taking about 75 to 80% of the a.a.r. and assuming a suitable runoff coefficient.

The rainfall of an average bad year $\approx \frac{2}{3}$ to $\frac{3}{4}$ of the a.a.r., which may be taken for runoff computation. Further improvement over the a.a.r. is the dependable rainfall. The available annual rainfall records for about 35 years are arranged in the descending order and the rainfall of 75% dependability, *i.e.*, of the 27th year from the top is taken for runoff computation.*

Several empirical formulae have also been developed for estimating the maximum rate of runoff or Maximum Flood Discharge (MFQ) and these are given under Chapter-8 on Floods.

(ii) *Infiltration Method.* By deducting the infiltration loss, *i.e.*, the area under the infiltration curve, from the total precipitation or by the use of infiltration indices, which are already discussed. These methods are largely empirical and the derived values are applicable only when the rainfall characteristics and the initial soil moisture conditions are identical to those for which these are derived.

(iii) *Rational Method.* A rational approach is to obtain the yield of a catchment by assuming a suitable runoff coefficient.

$$\text{Yield} = CAP \quad \dots(4.19)$$

where A = area of catchment

P = precipitation

C = runoff coefficient

The value of the runoff coefficient C varies depending upon the soil type, vegetation geology etc. and the following Table 4.3 given by Richards may be taken as a guide.

Table 4.3 Runoff coefficients for various types of catchments

| <i>Type of catchment</i> | <i>Value of C</i> |
|---------------------------------------|-------------------|
| Rocky and impermeable | 0.8–1.0 |
| Slightly permeable, bare | 0.6–0.8 |
| Cultivated or covered with vegetation | 0.4–0.6 |
| Cultivated absorbent soil | 0.3–0.4 |
| Sandy soil | 0.2–0.3 |
| Heavy forest | 0.1–0.2 |

In the rational method, the drainage area is divided into a number of sub-areas and with the known times of concentration for different subareas the runoff contribution from each area is determined. The choice of the value of the runoff coefficient C for the different sub-areas is an important factor in the runoff computation by this method. This method of dividing the area into different zones by drawing lines of time contour, *i.e.*, isochrones, is illustrated in the following example.

*Frequency $F = \frac{m}{n} \times 100 \quad \therefore 75\% = \frac{m}{35} \times 100 \quad \therefore m = 27$

Example 4.3 A 4-hour rain of average intensity 1 cm/hr falls over the fern leaf type catchment as shown in Fig. 4.10. The time of concentration from the lines AA, BB, CC and DD are 1, 2, 3 and 4 hours, respectively, to the site 0 where the discharge measurements are made. The values of the runoff coefficient C are 0.5, 0.6, and 0.7 for the 1st, 2nd and 3rd hours of rainfall respectively and attains a constant value of 0.8 after 3 hours. Determine the discharge at site 0.

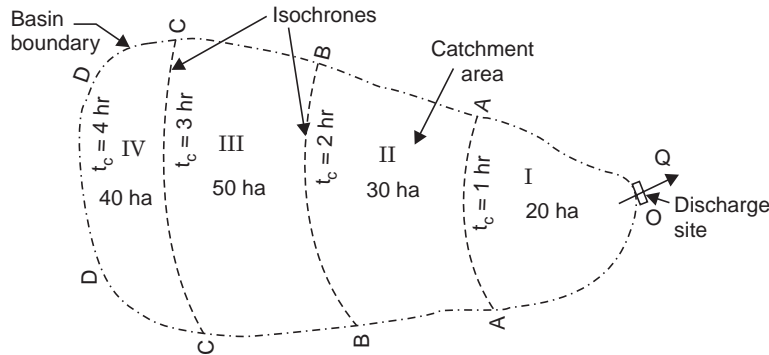

Fig. 4.10 Time of concentration method of runoff computation (Example 4.3)

Solution The discharge computations are made in Table 4.4.

Example 4.4 The following data are collected for a proposed tank in the Deccan plains of south India:

- Catchment area = 1200 ha
- a.a.r. = 90 cm
- Intensity of rainfall of duration 1 hr and frequency 35 years = 5 cm/hr
- Average runoff coefficient for the whole catchment = 20%
- Tank gets filled = $1\frac{1}{2}$ times in a year
- Difference between the maximum water level (MWL) and full tank level (FTL) = 0.6 m
- Determine

- (a) the yield of the catchment and the capacity of the tank
- (b) the area of rice crop that can be irrigated from the tank
- (c) the duties of water assumed and the discharge at the head to the distributary
- (d) the length of clear overfall weir near one flank.

Solution A.A.R. is available only in 50% of the years. To ensure filler of the tank in deficient years dependable rainfall $\approx 75\%$ of a.a.r.

$$= 0.75 \times 90 = 67.5 \text{ cm or } 0.675 \text{ m.}$$

Corresponding to this rain (P) of 75% dependability, the runoff (R) can be found from Eq. (4.10).

$$R = \frac{(P - 17.8)P}{254} = \frac{(67.5 - 17.8) 67.5}{254} = 13.2 \text{ cm}$$

Since the runoff coefficient $C = 20\%$ (given)

$$R = CP = 0.20 \times 67.5 = 13.5 \text{ cm}$$

which compares well with the value obtained above by applying the empirical formula for the region.

Yield from the catchment = $CAP = 0.2 \times 1200 \times 0.675 = 162 \text{ ha-m}$

Since the tank gets filled $1\frac{1}{2}$ times in a year,

$$\text{Capacity of the tank} = \frac{162}{1.5} = 108 \text{ ha-m}$$

(b) Assuming loss of water due to evaporation and seepage as 10% in the tank and 20% in the distributary

Water available at the field outlet = $162 (1 - 0.3) = 113.4 \text{ ha-m}$

For rice crop assuming $U = 88 \text{ cm}$, crop period $B = 120 \text{ days}$

$$\begin{aligned} \text{Field irrigation requirement } \Delta &= \frac{U}{\eta_{\text{irrgn}}} = \frac{88}{0.7} \\ &= 126 \text{ cm} \quad \text{or} \quad 1.26 \text{ m} = 1.26 \text{ ha-m/ha} \end{aligned}$$

Area of rice crop that can be irrigated

$$= \frac{113.4 \text{ ha-m}}{1.26 \text{ m}} = 90 \text{ ha}$$

(c) Tank duty = $\frac{1 - 0.3}{1.26} = 0.555 \text{ ha/ha-m}$ of annual storage (*i.e.*, yield)

For 1 Mm³: $\frac{(1 - 0.3) 10^6 \text{ m}^3}{1.26 \times 10^4 \text{ m}^2 / \text{ha}} = 55.5 \text{ ha/Mm}^3$ of annual storage

Note: $162 \times 0.555 = 90 \text{ ha}$

Flow duty (D) as ha/cumec on field can be obtained from equal volumes

$$\begin{aligned} 1 \frac{\text{m}^3}{\text{sec}} (B \text{ days} \times 86400 \text{ sec}) &= (D \times 10^4 \text{ m}^2) \Delta \text{m} \\ \therefore D &= \frac{8.64 B}{\Delta} = \frac{8.64 \times 120 \text{ days}}{1.26 \text{ m}} = 823 \text{ ha/cumec} \end{aligned}$$

Discharge at field outlet = $\frac{90}{823} = 0.1093 \text{ cumec}$

Discharge at the head of the distributary, *i.e.*, tank outlet

$$= 0.1093/0.80 = 0.137 \text{ cumec} = 137 \text{ lps}$$

(d) Length of the clear overfall weir (L):

Using the rational formula for the maximum rate of runoff

$$Q = CiA = 0.2 \frac{5}{100 (60 \times 60)} (1200 \times 10^4) = 33.3 \text{ cumec}$$

Weir formula is $Q = CLH^{3/2}$

Head over the weir $H = MWL - FTL = 0.6$ m, L = length of the weir

Assuming a weir coefficient C of 1.84, the weir formula becomes

$$\therefore 33.3 = 1.84 L (0.6)^{3/2}$$

$$\therefore L = 39 \text{ m}$$

Note. This example helps to distinguish between the hydrologic design and the hydraulic design. The hydrologic design consists of arriving at the minimum rate of runoff (yield) and maximum rate of runoff (flood) from a catchment, while the hydraulic design helps to design the storage capacity of the tank, the tank outlet, the outlet on the field, the design of the distributary (as open channel) and the length of the clear overfall weir and other appurtenances (from the principles of hydraulic engineering). Similarly hydrologic studies are made to arrive at the design flood for a spillway or bridge, and the hydraulic design consists of computing the length of spillway (for a desired head over the spillway) or calculating HFL, afflux and lineal water way for bridge openings, etc.

(iv) *Overland Flow Hydrograph.* Overland flow occurs as a thin sheet of water over the ground surface (soon after a storm starts), joins a stream channel, and then flows in the channel to the concentration point. Overland flow is relatively slow and is the dominant type of flow in the case of very small areas such as air ports, municipal block areas and flow from broad surfaces into storm drains and gutters. But in the case of large drainage areas, the length of overland flow is so short in comparison with the channel flow distance (before reaching the concentration point) that the total concentration time is mainly a function of channel velocity.

Overland flow is essentially a uniform flow over the surface (Fig. 4.11) as developed by C.F. Izzard (1948). The Reynolds number

$$R_e = \frac{Vd}{\nu} = \frac{q}{\nu} \quad \dots(4.20)$$

where V = velocity of flow

d = uniform depth of flow

ν = kinematic viscosity of water

q = discharge per unit width

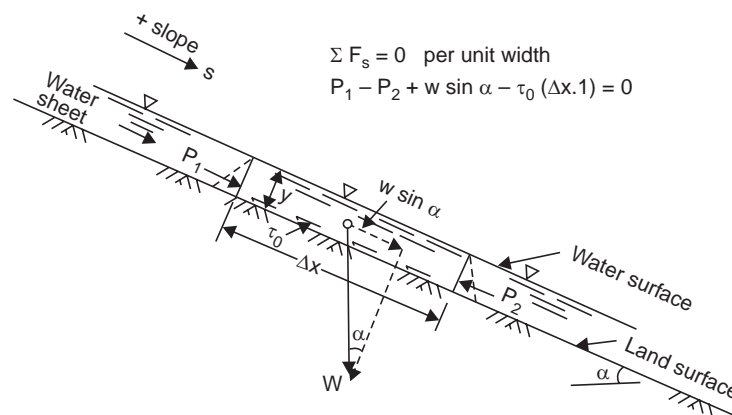

Fig. 4.11 Laminar overland flow analysis (after C.F. Izzard, 1948)

Experiments indicate that the overland flow can be assumed to be laminar if $R_e \leq 1000$ and turbulent if $R_e > 1000$ with a transition region of uncertainty in the vicinity of $R_e = 1000$. Izzard suggested that for rectangular drainage areas, laminar flow can be assumed if the product $i_{\text{net}} \times l \geq 400$, where i_{net} is the net rainfall in cm/hr and l is the length of overland flow in metres. Finite difference methods, based upon the method of characteristics have also been used to develop overland flow hydrographs.

(v) *Unit Hydrograph Method.* The hydrograph of direct surface discharge measured at the outlet of drainage area, which produces a unit depth of direct runoff (*i.e.*, a P_{net} of 1 cm over the entire area of the catchment) resulting from a unit storm of specified duration (called *unit period*) is called a *unit hydrograph* of that duration. The unit hydrograph method was first proposed by L.K. Sherman in 1932. The area under the hydrograph represents a direct runoff of 1 cm, Fig. 4.12.

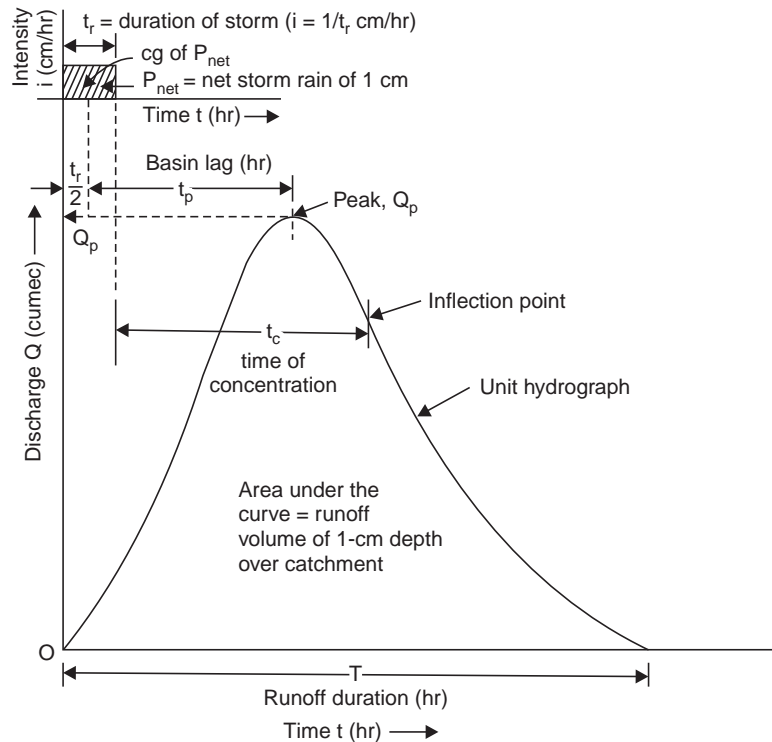

Fig. 4.12 Unit hydrograph

The theory of unit hydrograph is based on the following assumptions:

- (i) The net rainfall is of uniform intensity within its duration (*i.e.*, unit period).
- (ii) The net rainfall uniformly occurs over the entire area of the drainage basin.
- (iii) For a given drainage basin, the base period of the hydrographs of direct runoff corresponding to net rains of different intensities but same unit duration, is constant.
- (iv) The ordinates of direct runoff hydrographs due to net rains of different intensities (but same unit duration) are proportional.
- (v) A unit hydrograph reflects all the physical characteristics of the basin.

Application of the Unit Hydrograph. First a unit hydrograph of suitable unit duration is derived from an observed flood hydrograph for the drainage basin due to a known storm (storm loss and net rain). The unit hydrograph so derived can be applied for any other storm (of the same duration but producing different net rain) occurring on the basin and the resulting flood hydrographs can be obtained.

The details of the derivation of unit hydrographs and their application, given a unit hydrograph of one duration to derive a unit hydrograph of some other duration, and derivation of unit hydrographs for meteorologically homogeneous catchments (*i.e.*, from basin characteristics like shape, size, slope etc. when the stream-outflows are not gauged) are given in Chapter—5.

Example 4.5 A small watershed consists of 1.5 km² of cultivated area ($c = 0.2$), 2.5 km² under forest ($c = 0.1$) and 1 km² under grass cover ($c = 0.35$). There is a fall of 20 m in a watercourse of length 2 km. The I–D–F relation for the area is given by $I = \frac{80 T^{0.2}}{(t + 12)^{0.5}}$, I in cm/hr, T –yr, t –min.

Estimate the peak rate of runoff for a 25-year frequency.

Solution Time of concentration (Kirpich's formula—modified)

$$t_c \approx 0.02 L^{0.8} S^{-0.4}, \quad t_c \text{ in min, } L \text{ in metres}$$

$$= 0.02 (2000)^{0.8} \left(\frac{20}{2000} \right)^{-0.4} = 55 \text{ min} = t$$

$$I = \frac{80 \times 25^{0.2}}{(55 + 12)^{0.5}} = 18.6 \text{ cm/hr}$$

$$Q = CIA = 2.78 I (\Sigma C_i A_i) = 2.78 \times 18.6 (1.5 \times 0.2 + 2.5 \times 0.1 + 1 \times 0.35)$$

$$= 46.5 \text{ Cumec}$$

QUIZ IV

I Match the items in 'A' with the items in 'B'

A

- (i) Isochrone
- (ii) Runoff coefficient
- (iii) Unit hydrograph
- (iv) Compactness coefficient
- (v) Effluent streams
- (vi) Ephemeral streams
- (vii) Drainage divide
- (viii) Overland flow hydrograph

B

- (a) C.F. Izzard
- (b) Topographic ridge
- (c) Arid region
- (d) Perennial streams
- (e) Shape of drainage basin
- (f) 1 cm of runoff
- (g) Yield of catchment
- (h) Time-contours of commencement of storm

II Say 'true' or 'false' if false, give the correct statement.

- (i) Direct runoff is the sum of overland flow and interflow.
- (ii) In a perennial stream the ground water table is always below the bed of the stream while the ground water table is always above the bed in an ephemeral stream.

- (iii) Bank storage is the portion of runoff stored in the permeable banks of a stream due to a rising flood.
- (iv) The drainage density varies directly as the length of overland flow and indicates the drainage efficiency of the basin.
- (v) Quick intense floods occur more in fern-shaped catchments than in fan-shaped catchments.
- (vi) For the same intensity of rainfall, the flood discharge from a relatively small catchment is higher than that from a relatively large catchment.
- (vii) Vegetation tends to increase the runoff from the catchment. (false: ii, iv, v, vii)

III Choose the correct statement/s in the following:

- 1 Maximum surface runoff is favoured due to
 - (i) presence of forest area
 - (ii) a flash storm
 - (iii) presence of a recharge area, which replenishes the ground water storage
 - (iv) leaf-shaped catchment
 - (v) fan-shaped catchment
 - (vi) storm movement opposite to the stream flow
 - (vii) humid climate
 - (viii) improved land management
 - 2 An influent stream is due to
 - (i) a river crossing a desert area
 - (ii) effluent seepage from the basin
 - (iii) ground water table being above the stream bed
 - (iv) base flow
 - (v) direct surface runoff
 - (vi) being ephemeral in nature
- (1—ii, v, vii; 2—i, v, vi)

QUESTIONS

- 1 Name three forms in which water is stored on a catchment.
- 2 What is meant by 'the water balance of a catchment'?
- 3 Discuss the various factors, which affect the runoff from a basin.
- 4 (a) What are the methods of estimating runoff from a catchment?
(b) Give three empirical formulae applicable to particular regions in India.
- 5 How do you determine the yield from a catchment and arrive at the capacity of a tank?
- 6 Differentiate: Runoff, yield and maximum flood discharge.
- 7 Determine the yield of the catchment and the capacity of the tank from the following data:
 - Catchment area = 20 km²
 - a.a.r. = 80 cm
 - Tank gets filled: 2 times in a year
 - Runoff coefficient = $\frac{1}{5}$ (average for the catchment) (2, 4, 1.2 Mm³)

- 8 Explain the terms: catchment area and drainage divide.

An irrigation tank has a catchment area of 30 km^2 and receives an annual rainfall of 90 cm. Assuming that 10% of the rainfall flows as 'runoff' from the catchment, calculate the area that can be brought under paddy cultivation under the tank. Assume that the tank fills one and a half times in a year and the water requirement of paddy (duty) is 100 ha-cm. (40.5 ha)

- 9 (a) Explain how the following physical characteristics of a catchment can be determined?

(i) Mean elevation

(ii) Mean slope

(b) Krishna River basin has an area of 258948 km^2 and length 1400 km. Calculate the form factor and elongation ratio. (0.132, 0.41)

- 10 Explain the terms: Catchment area, Drainage divide, and Ground water divide. An irrigation tank has a catchment area of 30 km^2 and the a.a.r. is 90 cm. Assuming that only 20% of the dependable rainfall is the runoff available. Calculate the capacity of the tank assuming that it fills one and a half times in a year.

Assuming a total depth of irrigation water for rice crop for 120 days as 1.25 m and 30% losses, what area of rice crop can come under the tank?

Work out the tank duty, field duty and the discharge required at the tank outlet.

What is the length of the clear overfall weir to dispose of flood waters, assuming an intensity of 5 cm/hr of 35-year frequency. (270 ha-m, 227 ha, 56 ha/Mm³, 828 ha/cumec, 343 lps, 97.5 m)

- 11 A catchment has a perimeter of 1020 km and an area of 38520 km^2 . Calculate the compactness coefficient.

- 12 Write short notes on

(i) Isochrones

(ii) Ephemeral streams

(iii) Time of concentration

(iv) Overland flow hydrograph

(v) Runoff cycle

(vi) Valley storage

(vii) Bank storage

- 13 Distinguish between

(i) Overland flow and interflow

(ii) Influent and effluent streams

(iii) Detention storage and depression storage

(iv) Drainage density and drainage divide

(v) Form factor and compactness coefficient of a catchment

Chapter 5

HYDROGRAPHS

5.1 HYDROGRAPH COMPONENTS

A hydrograph is a graph showing discharge (*i.e.*, stream flow at the concentration point) versus time. The various components of a natural hydrograph are shown in Fig. 5.1. At the beginning, there is only base flow (*i.e.*, the ground water contribution to the stream) gradually depleting in an exponential form. After the storm commences, the initial losses like interception and infiltration are met and then the surface flow begins. The hydrograph gradually rises

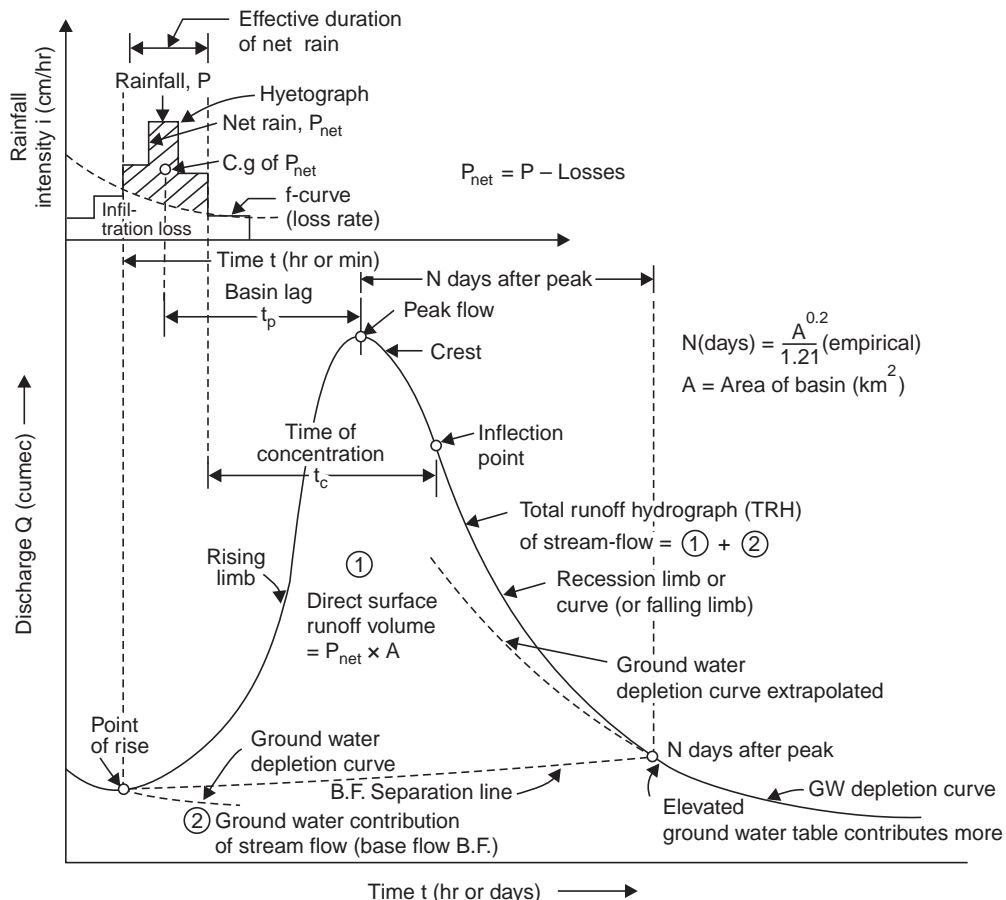

Fig. 5.1 Components of streamflow hydrograph

and reaches its peak value after a time t_p (called *lag time* or *basin lag*) measured from the centroid of the hyetograph of net rain. Thereafter it declines and there is a change of slope at the inflection point, *i.e.*, there has been, inflow of the rain up to this point and after this there is gradual withdrawal of catchment storage. By this time the ground water table has been built up by the infiltrating and percolating water, and now the ground water contributes more into the stream flow than at the beginning of storm, but thereafter the GWT declines and the hydrograph again goes on depleting in the exponential form called the *ground water depletion curve* or the *recession curve*. If a second storm occurs now, again the hydrograph starts rising till it reaches the new peak and then falls and the ground water recession begins, Fig. 5.2.

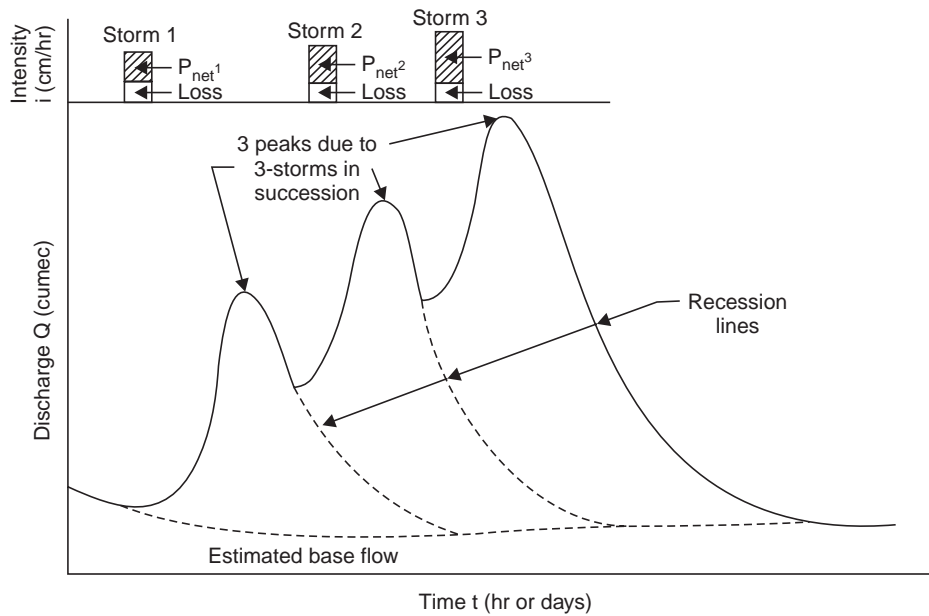

Fig. 5.2 Hydrograph with multiple peaks

Thus, in actual streams gauged, the hydrograph may have a single peak or multiple peaks according to the complexity of storms. For flood analysis and derivation of unit hydrograph, a single peaked hydrograph is preferred. A complex hydrograph, however, can be resolved into simple hydrographs by drawing hypothetical recession lines as shown in Fig. 5.2.

It has been found from many hydrographs that the ground water depletion curves for a given drainage basin are nearly the same and hence it is termed as the normal ground water depletion curve. It has been found that such curves, or at least their segments, follow a simple inverse exponential function of the elapsed time of the form.

$$Q_t = Q_0 K_r^{-t} \quad \dots(5.1)$$

where Q_0 = discharge at start of period

Q_t = discharge at end of time t

K_r = recession constant

As Q_t is the derivations of storage with respect to time,

$$-d S_t = Q_t dt$$

$$\therefore S_t = - \int Q_t dt = - \int (Q_0 K_r^{-1}) dt$$

$$\therefore S_t = \frac{Q_0}{\log_e K_r} \quad \therefore \int a^x = \frac{a^x}{\log a} \quad \dots(5.2)$$

Hence, the discharge at any time is proportional to the water remaining in storage *i.e.*,

$$\frac{Q_0}{Q_t} = \frac{S_0}{S_t} \quad \dots(5.2 a)$$

Taking logarithms on both sides of Eq. (5.1)

$$\log Q_t = \log Q_0 - t \log K_r$$

which is in the straight line form $y = mx + c$ with $y = \log Q_t$, $x = t$, and $m = -\log K_r$. The value of K_r can be determined by plotting the recession data *i.e.*, Q_t vs. t on a semi-log paper, taking care to select periods of little or no direct runoff; see Example 17.3.

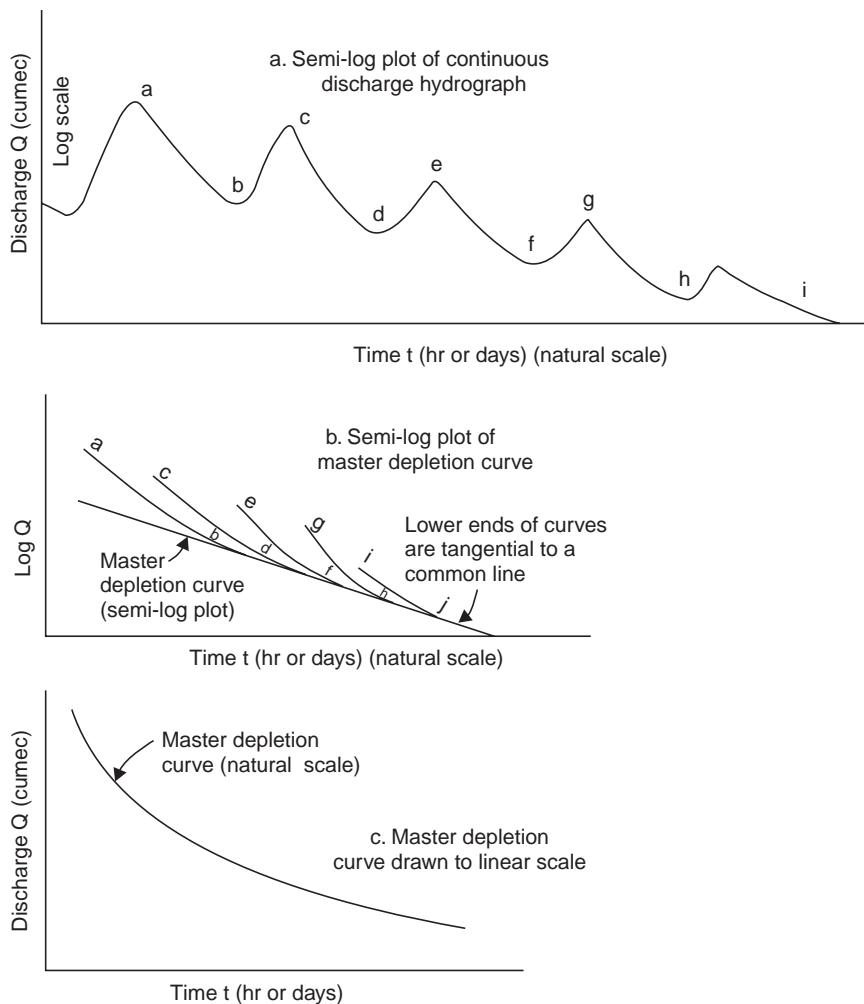

Fig. 5.3 Composite ground water depletion curve

If a continuous stream flow record is available for a number of years, the hydrograph can be plotted on a semi-log paper, *i.e.*, $\log Q$ vs. t , Fig. 5.3. Starting with the lowest recession flow line, a line is drawn tangential to the lower portion on a tracing paper. This tangent line is progressively extended by moving the tracing-paper towards the origin with the abscissae coincident, such that the line is tangential to the lower portion of the successive depletion curves of increasing magnitude. This common line is the log plot of the master depletion curve, which is then converted to linear vertical scale and is called the *composite ground water depletion curve*.

A composite ground water depletion curve can be constructed from the recession graphs resulting from a number of storms. The various segments of the recession graphs are shifted with respect to the time axis until they appear to match and then, an average or composite curve is drawn through them as shown in Fig. 5.4.

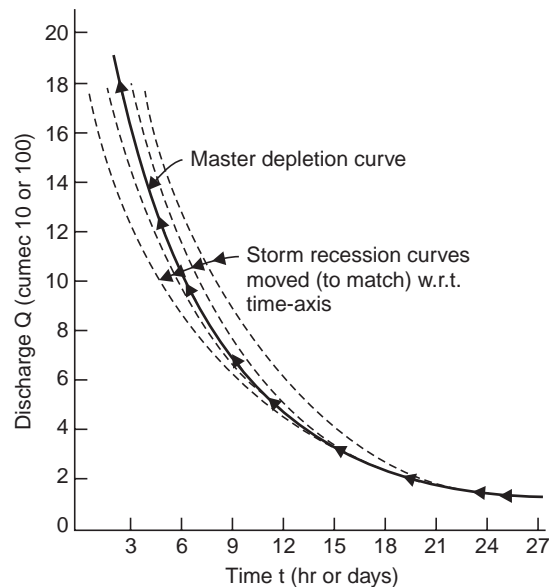

Fig. 5.4 Composite depletion curve

5.2 SEPARATION OF STREAMFLOW COMPONENTS

Barnes (1940) proposed that the stream flow components may be separated by plotting the hydrograph on a semi-log paper (Fig. 5.5). The tail end of the hydrograph plots as a straight line, *i.e.*, ground water recession (CD). If this straight line plot is extended backwards up to the point E directly under the inflection point I and line BE drawn, the area under BEC represents the ground water contribution to the stream flow. If the ordinates of this area are deducted from the ordinates of the total hydrograph and replotted, the hydrograph of surface runoff and interflow (subsurface flow) is obtained, which plots as a straight line (HG) at the tail end. By extending this line backwards up to the point L directly under I and drawing the line FL , the area under FLG gives the interflow component. By deducting the ordinates of this from the ordinates of the hydrograph of surface runoff and interflow, the hydrograph of surface runoff is replotted whose tail end again, may plot as a straight line representing the surface recession

or channel storage. The slopes of the straight line plots at the tail ends of the separated hydrographs give the respective recession constants.

Example 5.1 *The mean daily streamflow data from a drainage basin is given below. It is known that the recession limb of the discharge hydrograph has components of channel storage, interflow and base flow. Find the values of the recession coefficients for each of the three components.*

| Date | Mean daily discharge (cumec) | Date | Mean daily discharge (cumec) |
|--------------|---------------------------------|---------------|---------------------------------|
| 1978, Oct. 4 | 278 | 1978, Oct. 14 | 179 |
| 5 | 265 | 15 | 167 |
| 6 | 5350 | 16 | 157 |
| 7 | 8150 | 17 | 147 |
| 8 | 6580 | 18 | 139 |
| 9 | 1540 | 19 | 131 |
| 10 | 505 | 20 | 123 |
| 11 | 280 | 21 | 117 |
| 12 | 219 | 22 | 111 |
| 13 | 195 | 23 | 105 |
| | | 24 | 100 |

Also determine

(a) ground water storage on October 14, 1978.

(b) ground water storage and stream flow on October 30, 1978, assuming no rainfall during the period.

Solution The discharge hydrograph is drawn on a semi-log paper and the flow components are separated by the method proposed by Bernes as shown in Fig. 5.5. The recession coefficients (K_r) for the three components of base flow (ground water contribution), interflow and channel storage are computed as 1.059, 2.104 and 4.645, respectively.

(a) Ground water storage (S_0) on October 14, 1978 when the ground water depletion starts.

$$S_0 = \frac{Q_0}{\log_e k_r} = \frac{179 \times 86400 \text{ m}^3/\text{day}}{\log_e 1.06/\text{day}} = 2.75 \times 10^8 \text{ m}^3$$

(b) Stream flow on October 30, 1978, i.e., after 16 days

$$Q_t = Q_0 K_r^{-t}$$

$$Q_{16 \text{ days}} = 179 (1.06)^{-16} = 71.6 \text{ cumec}$$

Ground water storage (S_t) on October 30, 1978 can be determined from

$$\frac{Q_0}{Q_t} = \frac{S_0}{S_t}$$

or

$$S_t = S_0 \times \frac{Q_t}{Q_0}$$

$$\therefore S_{16 \text{ days}} = (2.75 \times 10^8) \frac{71.6}{179} = 1.10 \times 10^8 \text{ m}^3$$

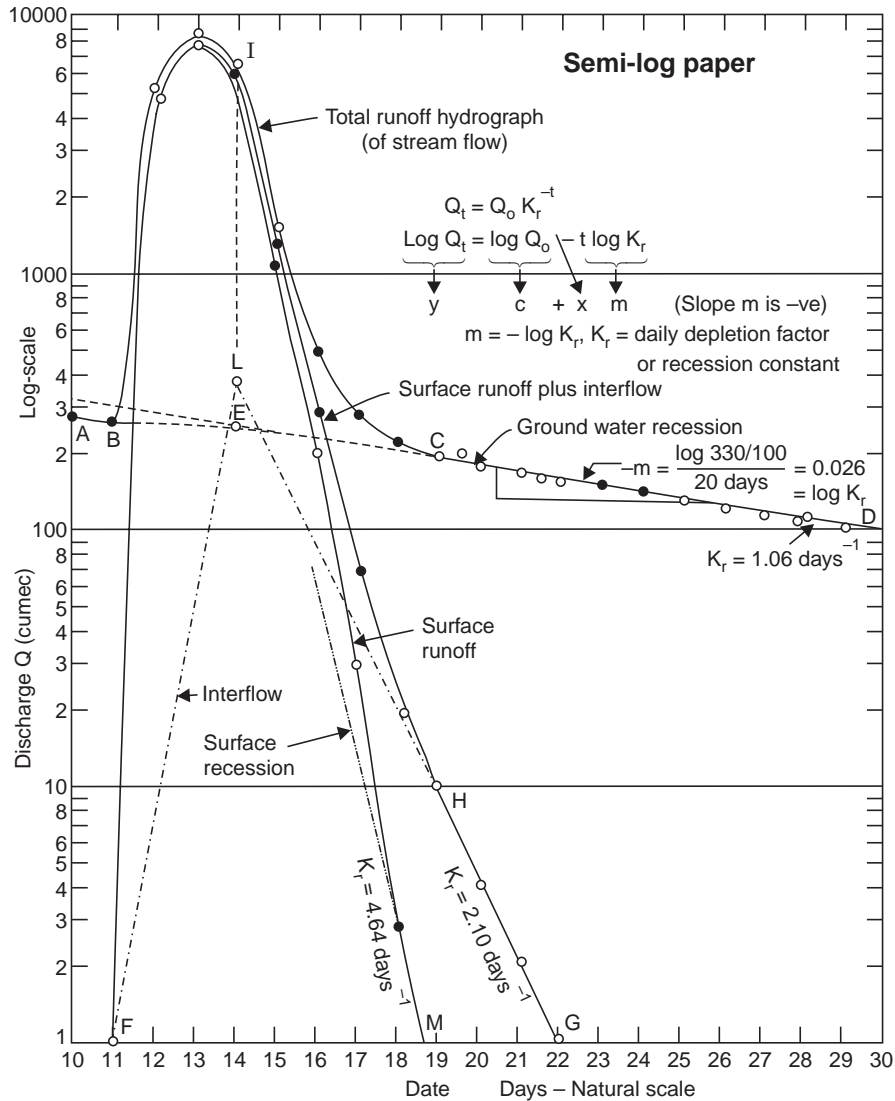

Fig. 5.5 Separation of streamflow components (after Barnes, 1940)

5.3 HYDROGRAPH SEPARATION

For the derivation of unit hydrograph, the base flow has to be separated from the total runoff hydrograph (i.e., from the hydrograph of the gauged stream flow). Some of the well-known base flow separation procedures are given below, Fig. 5.6.

(i) Simply by drawing a line AC tangential to both the limbs at their lower portion. This method is very simple but is approximate and can be used only for preliminary estimates.

(ii) Extending the recession curve existing prior to the occurrence of the storm up to the point D directly under the peak of the hydrograph and then drawing a straight line DE, where E is a point on the hydrograph N days after the peak, and N (in days) is given by

$$N = 0.83 A^{0.2} \tag{5.3}$$

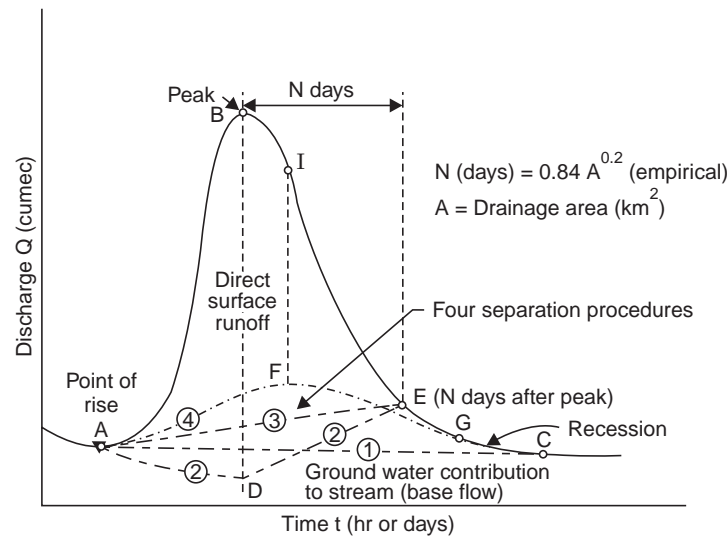

Fig. 5.6 Hydrograph separation

where A = area of the drainage basin, km^2 and the size of the areas of the drainage basin as a guide for the values of N are given below :

| | | | | | |
|--|-----|------|------|-------|-------|
| Area of drainage basin (km^2) | 250 | 1250 | 5000 | 12500 | 25000 |
| Time after peak, N (days) | 2 | 3 | 4 | 5 | 6 |

(iii) Simply by drawing a straight line AE , from the point of rise to the point E , on the hydrograph, N days after the peak.

(iv) Construct a line AFG by projecting backwards the ground water recession curve after the storm, to a point F directly under the inflection point of the falling limb and sketch an arbitrary rising line from the point of rise of the hydrograph to connect with the projected base flow recession. This type of separation is preferred where the ground water storage is relatively large and reaches the stream fairly rapidly, as in lime-stone terrains.

Many a time a straight line AE meets the requirements for practical purposes. Location of the point E is where the slope of the recession curve changes abruptly, and as a rough guide E is N days after the peak. In all the above four separation procedures, the area below the line constructed represents the base flow, *i.e.*, the ground water contribution to stream flow. Any further refinement in the base flow separation procedure may not be needed, since the base flow forms a very insignificant part of high floods. In fact, very often, a constant value of base flow is assumed.

In Fig. 5.7, ADE is the assumed base flow. Actually, when the water level in the stream rises due to floods, the stream feeds the ground water and the permeable boundaries (called *bank storage*, Fig. 5.8) and this is termed as *negative base flow*. But actually the variation in base flow may be much less than indicated in Fig. 5.7 depending on the permeability of the boundaries and the gradient of the phreatic surface. The resulting variation will be a slight dip from the extrapolated depletion curve, followed by a gradual rise to a higher level than the initial value as the flood recedes as shown in Fig. 5.9.

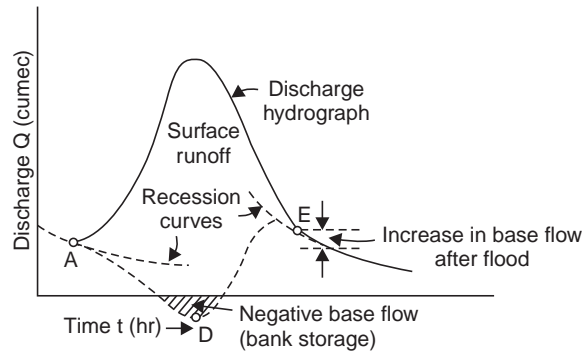

Fig. 5.7 Negative baseflow

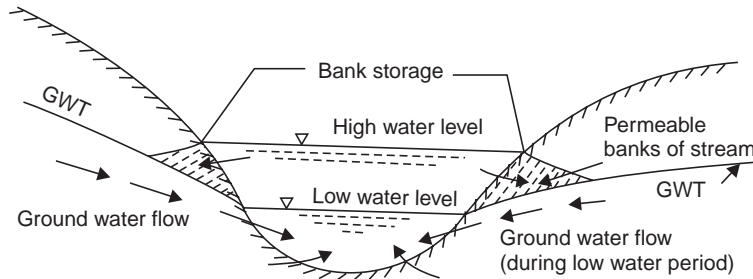

Fig. 5.8 Bank storage

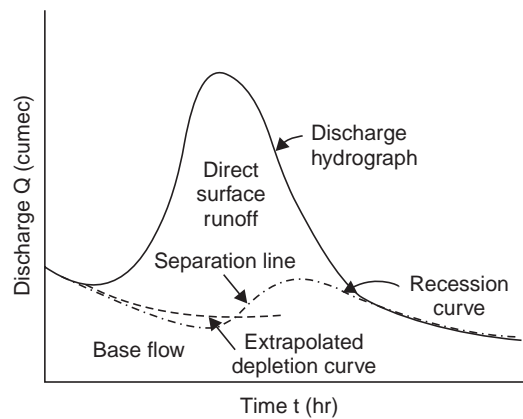

Fig. 5.9 Actual baseflow variation

5.4 UNIT HYDROGRAPH

The unit hydrograph is defined as the hydrograph of storm runoff resulting from an isolated rainfall of some unit duration occurring uniformly over the entire area of the catchment, produces a unit volume (*i.e.*, 1 cm) of runoff.

Derivation of the unit hydrographs. The following steps are adopted to derive a unit hydrograph from an observed flood hydrograph (Fig. 5.10).

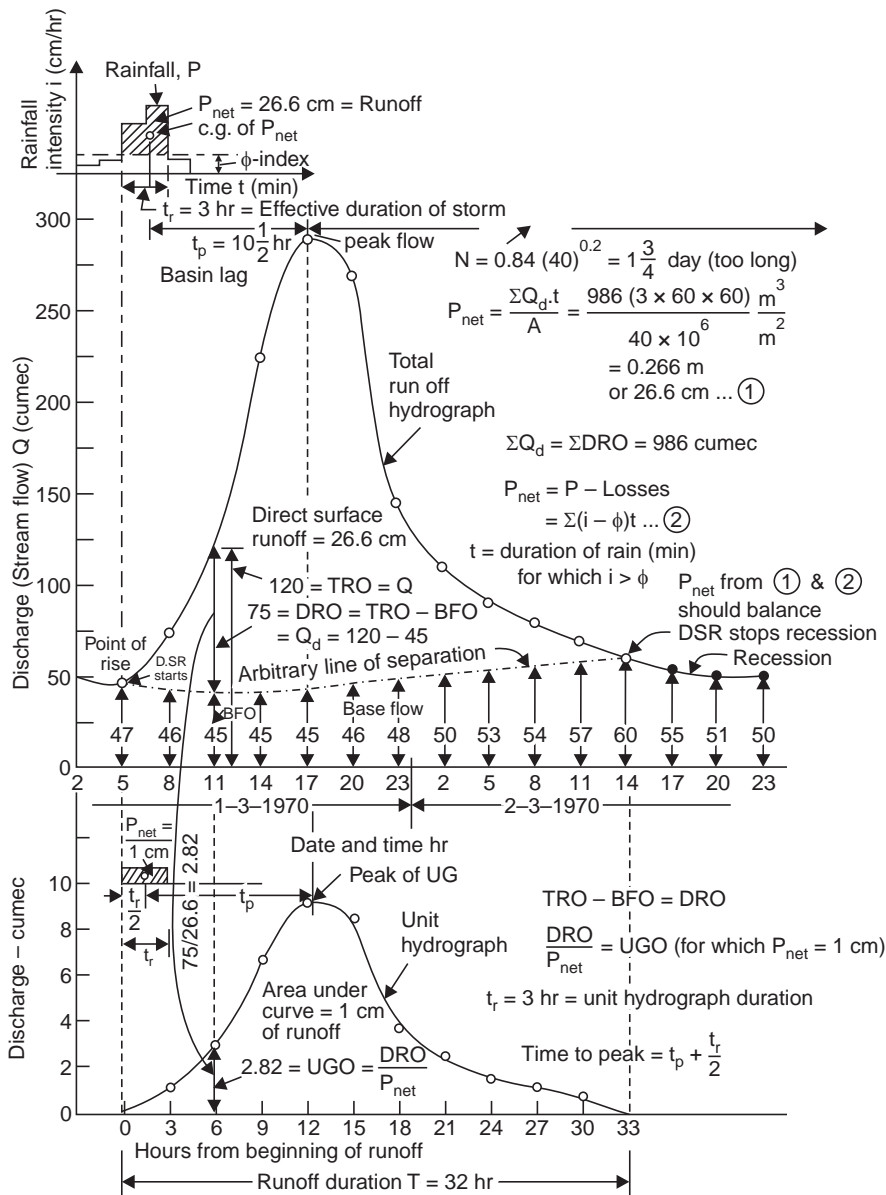

Fig. 5.10 Derivation of a unit hydrograph (Example 5.1)

(i) Select from the records isolated (single-peaked) intense storms, which occurring uniformly over the catchment have produced flood hydrographs with appreciable runoff (>1 cm, say, 8 to 16 cm). The unit period selected should be such that the excess rainfall (*i.e.*, P_{net}) occurs fairly uniformly over the entire drainage basin. Larger unit periods are required for larger basins. The unit periods may be in the range of 15-30% of the 'peak time' period, *i.e.*, the time from the beginning of surface runoff to the peak, and the typical unit periods may be 3, 6, 8, 12 hours. (The time of concentration may be a little longer than the peak time).

The unit storm is a storm of such duration that the period of surface runoff is not much less for any other storm of shorter duration.

(ii) Select a flood hydrograph, which has resulted from a unit storm chosen in item (i) above.

(iii) Separate the base flow from the total runoff (by the well-known base flow separation procedures).

(iv) From the ordinates of the total runoff hydrograph (at regular time intervals) deduct the corresponding ordinates of base flow, to obtain the ordinates of direct runoff.

(v) Divide the volume of direct runoff by the area of the drainage basin to obtain the net precipitation depth over the basin.

(vi) Divide each of the ordinates of direct runoff by the net precipitation depth to obtain the ordinates of the unit hydrograph.

(vii) Plot the ordinates of the unit hydrograph against time since the beginning of direct runoff. This will give the unit hydrograph for the basin, for the duration of the unit storm (producing the flood hydrograph) selected in item (i) above.

In unit hydrograph derivation, such storms should be selected for which reliable rainfall and runoff data are available. The net rain graph (hyetograph of excess rain) should be determined by deducting the storm loss and adjusting such that the total volume of net storm rain is equal to the total volume of direct surface runoff. The unit hydrograph derived, which, when applied to the known net rain data, should yield the known direct runoff hydrograph.

The steps given above for the derivation of unit hydrograph can be formulated as follows (exemplified in Fig. 5.10).

$$P_{\text{net}} = P - \text{Losses} \quad \dots(5.4)$$

$$\text{or } P_{\text{net}} = \frac{\sum Q_d t}{A}, \quad Q_d = DRO \quad \dots(5.4 a)$$

$$TRO - BFO = DRO \quad \dots(5.4 b)$$

$$\frac{DRO}{P_{\text{net}}} = UGO \quad \dots(5.4 c)$$

where P = total rainfall

P_{net} = net precipitation (from hyetograph) or direct runoff as equivalent depth over the basin.

Losses = due to infiltration (F_p), etc.

A = area of the drainage basin

Q_d , DRO = direct runoff ordinate

TRO = total runoff ordinate

t = time interval between successive direct runoff ordinates

BFO = base flow ordinate

Elements of unit hydrograph. The various elements of a unit hydrograph are shown in Fig. 5.11.

Base width (T)—The period of direct surface runoff (due to a unit storm) of the unit hydrograph is called the *time base* or the *base width*.

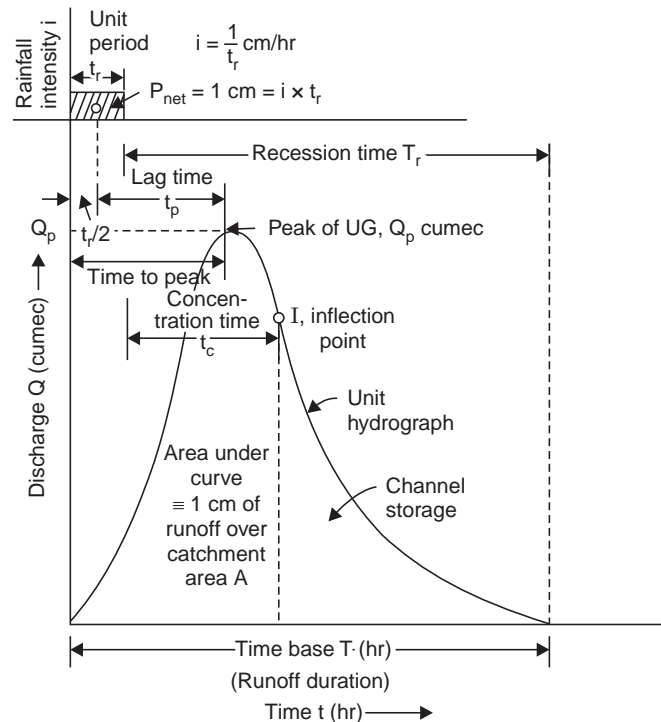

Fig. 5.11 Elements of unit hydrograph

Unit storm—The storm of unit duration (*i.e.*, duration of the unit hydrograph) regardless of its intensity is called *unit storm*.

Unit period—The time duration of the unit storm (*i.e.*, the duration of the unit hydrograph) is called *unit period*.

Lag time (t_p)—The time from the centre of a unit storm to the peak discharge of the corresponding unit hydrograph is called *lag time*.

Recession time (T_r)—The duration of the direct surface runoff after the end of the excess or net rainfall, is called *recession time in hydrograph analysis*.

Propositions of the Unit Hydrograph

The following are the basic propositions of the unit hydrograph:

(i) *Same runoff duration*. For all unit storms of different intensities, the period of surface runoff (*i.e.*, time base, base width or base period) is approximately the same, although they produce different runoff volumes (Fig. 5.12 (a)).

(ii) *Proportional ordinates*. For unit storms of different intensities, the ordinates of the hydrograph at any given time, are in the same proportion as the rainfall intensities (Fig. 5.12 (a)).

(iii) *Principle of superposition*. If there is a continuous storm and/or isolated storms of uniform intensity net rain, they may be divided into unit storms and hydrographs of runoff for each storm obtained, and the ordinates added with the appropriate time lag to get the combined hydrograph (Fig. 5.12 (b)).

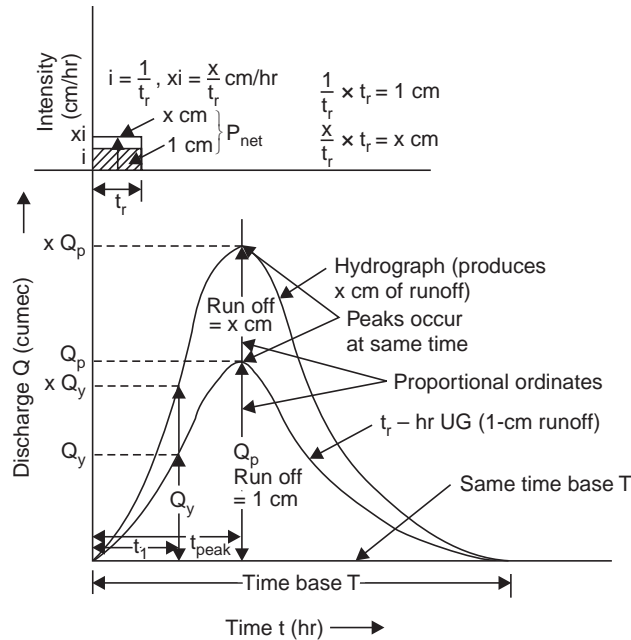

(a) Proportional ordinates and same time base

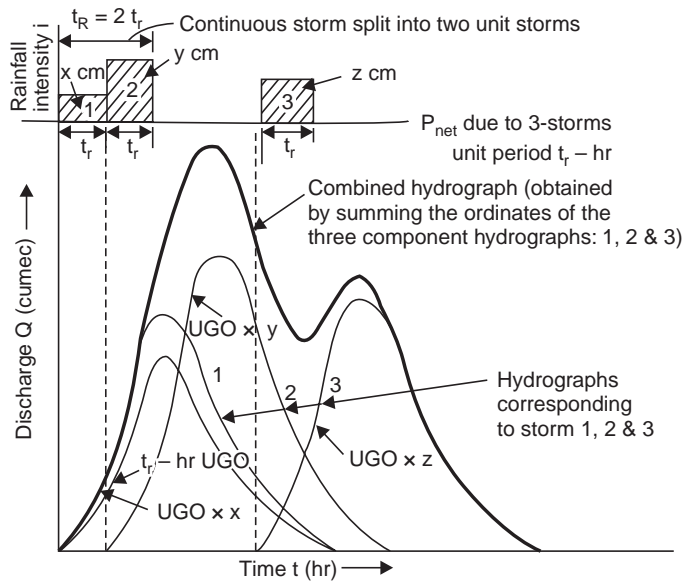

(b) Principle of superposition

Fig. 5.12 Propositions of unit hydrograph

(iv) *Same distribution percentages.* If the total period of surface runoff (*i.e.*, time base or base width) is divided into equal time intervals the percentage of surface runoff that occurs during each of these periods will be same for all unit storms of different intensities (Fig. 5.13).

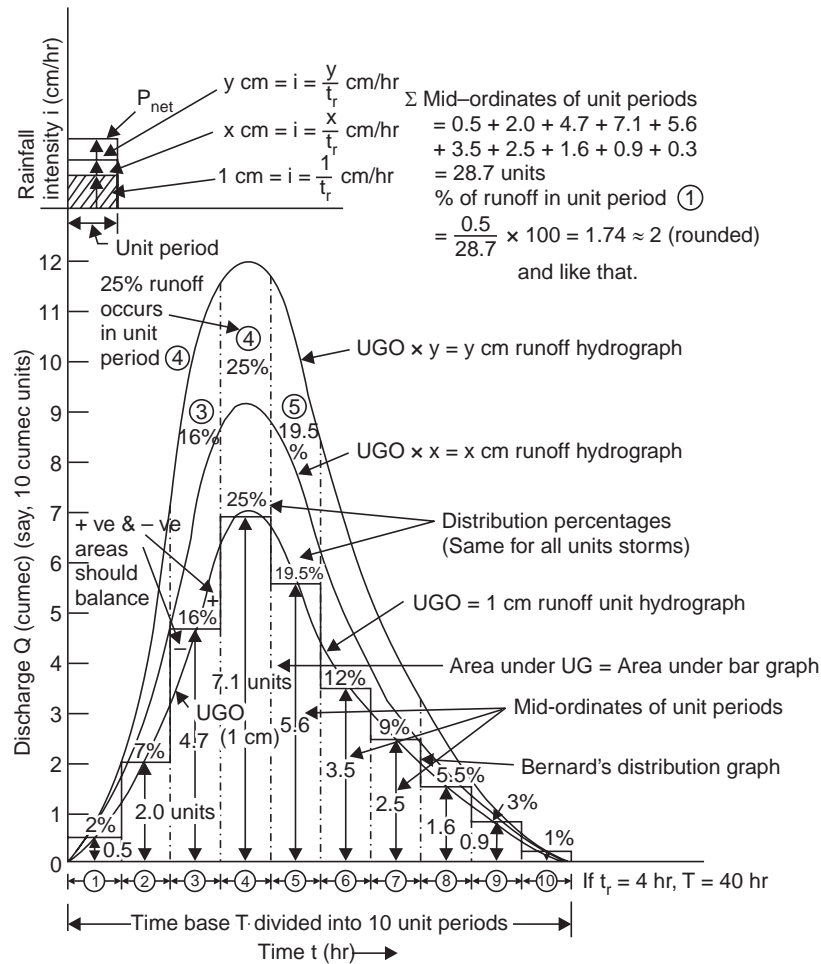

Fig. 5.13 Distribution percentages same for all unit storms

Limitation of the Unit Hydrograph. Certain limitations are inherent in the unit hydrograph theory. The runoff hydrograph reflects the combined effects of rainfall factors, loss factors and physiographic factors. The design storm continuing for several unit periods may not have the same areal distribution for each time increment. Storm movements also affect the proportions of the unit hydrograph if the basin is large. Hence, the unit hydrograph can not be applied for basins larger than 5000 km². For basins larger than 5000 km², unit hydrographs for the principal sub-areas or sub-basins are developed and the hydrographs of runoff determined for each sub-area. These hydrographs are then combined, through flood routing procedure, to get the resulting hydrograph at the required section.

Derivation of Unit Hydrograph

Example 5.1 (a) The runoff data at a stream gauging station for a flood are given below. The drainage area is 40 km². The duration of rainfall is 3 hours. Derive the 3-hour unit hydrograph for the basin and plot the same.

| <i>Date</i> | <i>Time (hr)</i> | <i>Discharge (cumec)</i> | <i>Remarks</i> |
|-------------|----------------------|------------------------------|----------------|
| 1-3-1970 | 2 | 50 | |
| | 5 | 47 | |
| | 8 | 75 | |
| | 11 | 120 | |
| | 14 | 225 | |
| | 17 | 290 | ← Peak |
| | 20 | 270 | |
| | 23 | 145 | |
| 2-3-1970 | 2 | 110 | |
| | 5 | 90 | |
| | 8 | 80 | |
| | 11 | 70 | |
| | 14 | 60 | |
| | 17 | 55 | |
| | 20 | 51 | |
| | 23 | 50 | |

State the peak of the unit hydrograph you derive.

Solution See Table 5.1.

5.5 UNIT HYDROGRAPH FROM COMPLEX STORMS

Unit hydrographs from complex storms, involving varying intensities of rain can be obtained by considering the complex storm as successive unit storms of different intensities and the runoff hydrograph (due to complex storm) as the result of superposition of the successive storm hydrographs. The ordinates of each storm hydrograph are obtained as ‘the storm intensity times the corresponding ordinate of the unit hydrograph’ as shown in Fig. 5.14. The unit hydrograph ordinates u_1, u_2, \dots are thus obtained by writing a series of equations for each of the ordinates Q_1, Q_2, \dots of the runoff hydrograph (due to complex storm) and successively solving them. In Fig. 5.14,

$$Q_1 = xu_1 \quad \therefore \quad u_1 = ?$$

$$Q_2 = xu_2 + yu_1 \quad \therefore \quad u_2 = ?$$

$$Q_3 = xu_3 + yu_2 + zu_1 \quad \therefore \quad u_3 = ?$$

and so on. Thus, the t_r -hour unit graph ordinates can be determined. Although the method is straight forward, errors will creep in due to the assumptions on the intensity and duration of rainfall and deduction of an assumed base flow; many trials are required to get a reasonable unit graph.

Table 5.1 Derivation of the 3-hour unit hydrograph. Example 5.1

| <i>Date</i> | <i>Time (hr)</i> | <i>TRO</i> ¹ (cumec) | <i>BFO</i> ² (cumec) | <i>DRO</i> ² (3)–(4) (cumec) | <i>UGO</i> ⁴ (5) ÷ <i>P</i> _{net} (cumec) | <i>Time</i> ⁵ from begin- ning of surface run off (hr) |
|-------------|----------------------|------------------------------------|------------------------------------|---|---|---|
| 1 | 2 | 3 | 4 | 5 | 6 | 7 |
| 1-3-1970 | 2 | 50 | 50 | — | — | — |
| | 5 | 47 | 47 | 0 | 0 | 0 |
| | 8 | 75 | 46 | 29 | 1.09 | 3 |
| | 11 | 120 | 45 | 75 | 2.82 | 6 |
| | 14 | 225 | 45 | 180 | 6.77 | 9 |
| | 17 | 290 | 45 | 245 | 9.23 | 12 |
| | 20 | 270 | 46 | 224 | 8.44 | 15 |
| 2-3-1970 | 23 | 145 | 48 | 97 | 3.65 | 18 |
| | 2 | 110 | 50 | 60 | 2.26 | 21 |
| | 5 | 90 | 53 | 37 | 1.39 | 24 |
| | 8 | 80 | 54 | 26 | 0.98 | 27 |
| | 11 | 70 | 57 | 13 | 0.49 | 30 |
| | 14 | 60 | 60 | 0 | 0 | 33 |
| | 17 | 55 | 55 | — | — | — |
| | 20 | 51 | 51 | — | — | — |
| 23 | 50 | 50 | — | — | — | |
| | | | | Σ <i>DRO</i> = 986 cumec | | |

¹*TRO*—Total runoff ordinate = gauged discharge of stream

²*BFO*—Base flow ordiante read from graph separation line shown in Fig. 5.10 (a). $N = 0.83 A^{0.2} = 0.89(40)^{0.2} = 1.73$ days = $1.73 \times 24 = 41.4$ hr from peak, which is seen not applicable here; hence an arbitrary separation line is sketched.

³*DRO*—Direct runoff ordinate = *TRO*—*B.F.O.*

⁴*UGO*—Unit hydrograph ordinate

$$\begin{aligned}
 &= \frac{DRO}{P_{net}}; P_{net} = \frac{\Sigma DRO \cdot t}{A} = \frac{986(3 \times 60 \times 60)m^3}{40 \times 10^6 m^2} \\
 &= 0.266 m = 26.6 cm
 \end{aligned}$$

⁵Time from beginning of direct surface runoff is at 5 hr on 1-3-1970, which is reckoned 0 hr for unit hydrograph. The time base for unit hydrograph is 33 hours.

The 3-hour unit hydrogryph is plotted in Fig. 5.10 (b) to a different vertical scale and its peak is 9.23 cumec.

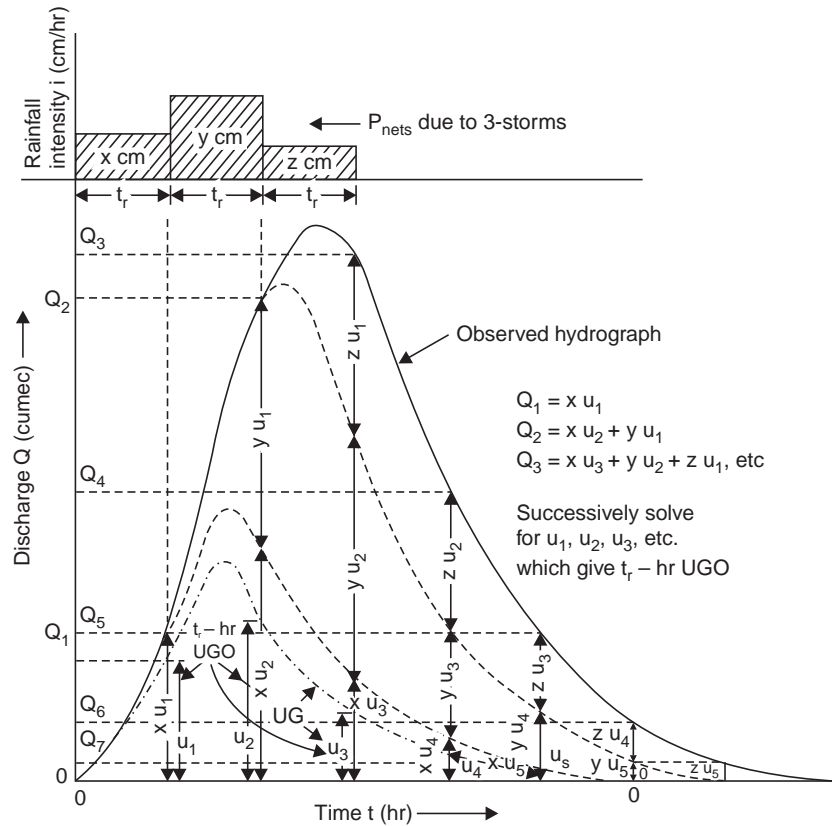

Fig. 5.14 Derivation of unit hydrograph from multi-period storms

Example 5.2 The stream flows due to three successive storms of 2.9, 4.9 and 3.9 cm of 6 hours duration each on a basin are given below. The area of the basin is 118.8 km². Assuming a constant base flow of 20 cumec, derive a 6-hour unit hydrograph for the basin. An average storm loss of 0.15 cm/hr can be assumed.

| | | | | | | | | | | | | |
|---------------|----|----|----|-----|-----|-----|-----|-----|------|------|----|----|
| Time (hr): | 0 | 3 | 6 | 9 | 12 | 15 | 18 | 21 | 24 | 27 | 30 | 33 |
| Flow (cumec): | 20 | 50 | 92 | 140 | 199 | 202 | 204 | 144 | 84.5 | 45.5 | 29 | 20 |

Solution Let the 6-hour unit hydrograph ordinates be $u_0, u_1, u_2, u_3, u_4, \dots, u_7$ at 0, 3, 6, 12, ..., 21 hours, respectively. The direct runoff ordinates due to the three successive storms (of 6 hours duration each) are obtained by deducting the base of flow of 20 cumec from the streamflows at the corresponding time intervals as shown in Table 5.2. The net storm rains are obtained by deducting the average storm loss as

$$\begin{aligned}
 0-6 \text{ hr: } x &= 2.9 - 0.15 \times 6 = 2 \text{ cm} \\
 6-12 \text{ hr: } y &= 4.9 - 0.15 \times 6 = 4 \text{ cm} \\
 12-18 \text{ hr: } z &= 3.9 - 0.15 \times 6 = 3 \text{ cm}
 \end{aligned}$$

The equations can be easily arrived by entering in a tabular column and successively solving them. The 6-hr unit hydrograph ordinates are obtained in the last column; of course the ordinates are at 3-hr intervals since the streamflows are recorded at 3-hr intervals. The

Table 5.2 Derivation of a 6-hour unit hydrograph from a complex storm, Example 5.2.

| Time (hr) | DRO due to** | | | Equation | | Solution 6-hr UGO |
|--------------|----------------------|----------------------|----------------------|---------------------------------|------------------------|----------------------|
| | 1st storm UGO × x | 2nd storm UGO × y | 3rd storm UGO × z | Total DRO = TRO — BFO | | |
| 0 | $u_0 = 0$ | — | — | $0 = 20 - 20$ | | $u_0 = 0$ |
| 3 | u_1 | — | — | $2u_1 = 50 - 20$ | | $u_1 = 15$ |
| 6 | u_2 | 0 | — | $2u_2 = 92 - 20$ | | $u_2 = 36$ |
| 9 | u_3 | $4u_1$ | — | $2u_3 + 4u_1 = 140 - 20$ | | $u_3 = 30$ |
| 12 | u_4 | $4u_2$ | 0 | $2u_4 + 4u_2 + 0 = 199 - 20$ | | $u_4 = 17.5$ |
| 15 | u_5 | $4u_3$ | $3u_1$ | $2u_5 + 4u_3 + 3u_1 = 202 - 20$ | | $u_5 = 8.5$ |
| 18 | u_6 | $4u_4$ | $3u_2$ | $2u_6 + 4u_4 + 2u_2 = 204 - 20$ | | $u_6 = 3$ |
| 21 | u_7 | $4u_5$ | $3u_3$ | $2u_7 + 4u_5 + 3u_3 = 144 - 20$ | | $u_7 = 0$ |
| 24 | | $4u_6$ | $3u_4$ | $4u_6 + 3u_4 = 84.5 - 20$ | | $\Sigma u = 110$ |
| 27 | | $4u_7$ | $3u_5$ | $4u_7 + 3u_5 = 45.5 - 20$ | $\therefore u_5 = 8.5$ | check for |
| 30 | | | $3u_6$ | $3u_6 = 29 - 20$ | $\therefore u_6 = 3$ | UGO derived |
| 33 | | | $3u_7$ | $3u_7 = 20 - 20$ | $\therefore u_7 = 0$ | above |

*Except the first column, all other columns are in cumec.

**x = 2 cm, y = 4 cm, z = 3 cm

last four equations in the table serve to check some of the *UGO*'s derived. Another check for the *UGO*'s derived is that the area under the *UG* should give a runoff volume equivalent to 1 cm, *i.e.*,

$$\frac{\sum u t}{A} = 1 \text{ cm, in consistent units}$$

$$\sum u = \text{sum of the } UGO\text{'s} = 110 \text{ cumec}$$

$$\therefore \frac{110 (3 \times 60 \times 60)}{118.8 \times 10^6} = 0.01 \text{ m, or } \mathbf{1 \text{ cm}}$$

Hence, the *UGO*'s derived are correct and is plotted in Fig. 5.15 (b).

The *UGO*'s can also be derived by the method of least squares (Snyder, 1955) by writing the direct runoff ordinate (*Q*) as

$$Q = a + b_1x_1 + b_2x_2 + b_3x_3 + \dots + b_ix_i \quad \dots(5.5)$$

where $a = 0$ theoretically, $b_i = u_i$, and x_1, x_2, x_3, \dots are the rainfall excesses (P_{net}) in successive periods. In the least square technique, data from a number of flood events, for which values of Q_i and x_i are established, are used to develop a set of average values of $b_i (= u_i)$ and the unit hydrograph derived. The method is more elegant but laborious.

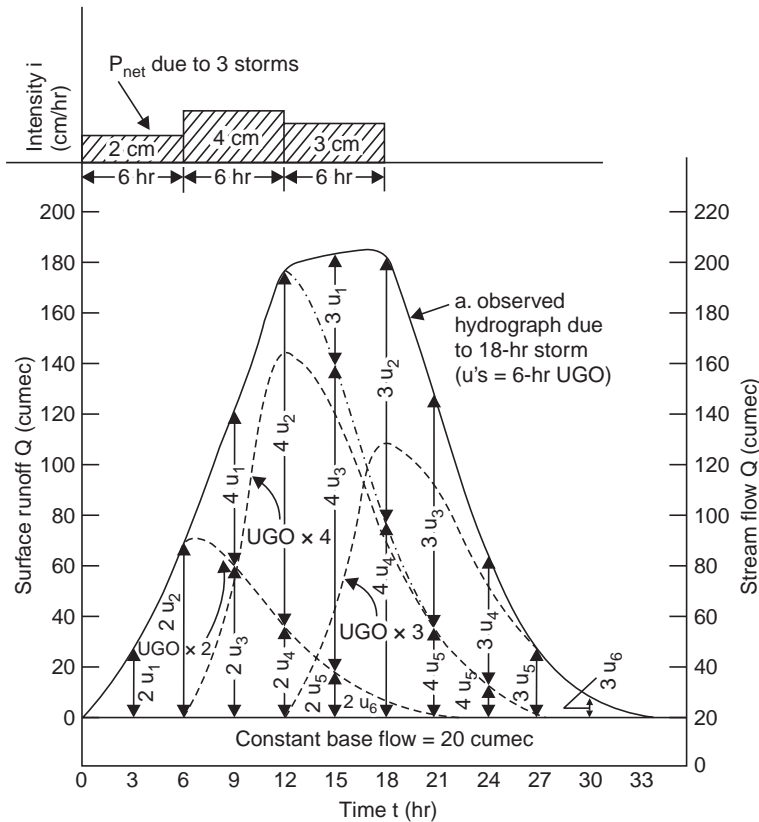

Fig. 5.15 (a) Derivation of 6-hr UG from 18-hr complex storm hydrograph (Example 5.2)

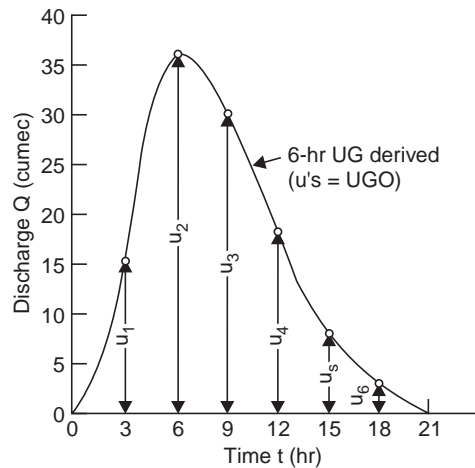

Fig. 5.15 (b) 6-hr unit hydrograph (derived) (Example 5.2)

Matrix method for unit hydrograph derivation from complex storm

In matrix notation

$$PU = Q$$

where $P = \begin{bmatrix} p_1 & 0 & 0 & 0 & 0 & 0 \\ p_2 & p_1 & 0 & 0 & 0 & 0 \\ p_3 & p_2 & p_1 & 0 & 0 & 0 \\ 0 & p_3 & p_2 & p_1 & 0 & 0 \\ 0 & 0 & p_3 & p_2 & 0 & 0 \\ 0 & 0 & 0 & p_3 & 0 & 0 \end{bmatrix}$ $U = \begin{bmatrix} u_1 \\ u_2 \\ u_3 \\ u_4 \\ 0 \\ 0 \end{bmatrix}$ $Q = \begin{bmatrix} q_1 \\ q_2 \\ q_3 \\ q_4 \\ q_5 \\ q_6 \end{bmatrix}$

By deducting base flow from the stream flow hydrograph Q is known, and with the known rainfall excess P , the unit hydrograph U can be computed as

$$U = P^{-1} Q$$

The inverse for the precipitation matrix (P^{-1}) exists only if it is a square matrix with a non-vanishing determinant. However, by the use of the transpose of the precipitation matrix, (P^T), a square matrix is obtained as

$$P^T P U = P^T Q$$

and the unit hydrograph matrix is obtained as

$$U = (P^T P)^{-1} P^T Q$$

Usually, the solution of the unit hydrograph matrix is performed on a digital computer (Newton, 1967). Most computer installations have packaged programmes to work with large systems and for determining the inverse and transpose of matrices.

Also, the number of streamflow hydrograph ordinates (n) is given by

$$n = j + i - 1$$

where j = number of UGO

i = number of periods of rainfall

In Example 5.2, $n = 12$ ordinates at 3-hr interval (DRO of the first and last being zero); $i = 6$ periods of 3-hr interval ($= 3 \times 2$), then

$$n = j + i - 1; \quad 12 = j + 6 - 1$$

$$\therefore \quad j = 7 \text{ UGO}$$

Thus, the unit hydrograph consists of 7 ordinates at 3-hr intervals (of course, $u_0 = 0$, and $u_7 = 0$).

As an assignment, the student is advised first to become well versed with the matrix algebra and then apply the matrix method to derive the 6-hr UGO at 3-hr interval from the streamflow data given in Example 5.2.

Average Unit Hydrograph. It is better if several unit graphs are derived for different isolated (single peaked) uniform intensity storms. If the durations of storms are different, the unit hydrographs may be altered to the same duration (sect or art). From several unit hydrographs for the same duration, so obtained, an average unit hydrograph can be sketched by computing the average of the peak flows and times to peak and sketching a median line, (Fig. 5.16), so that the area under the graph is equal to a runoff volume of 1 cm.

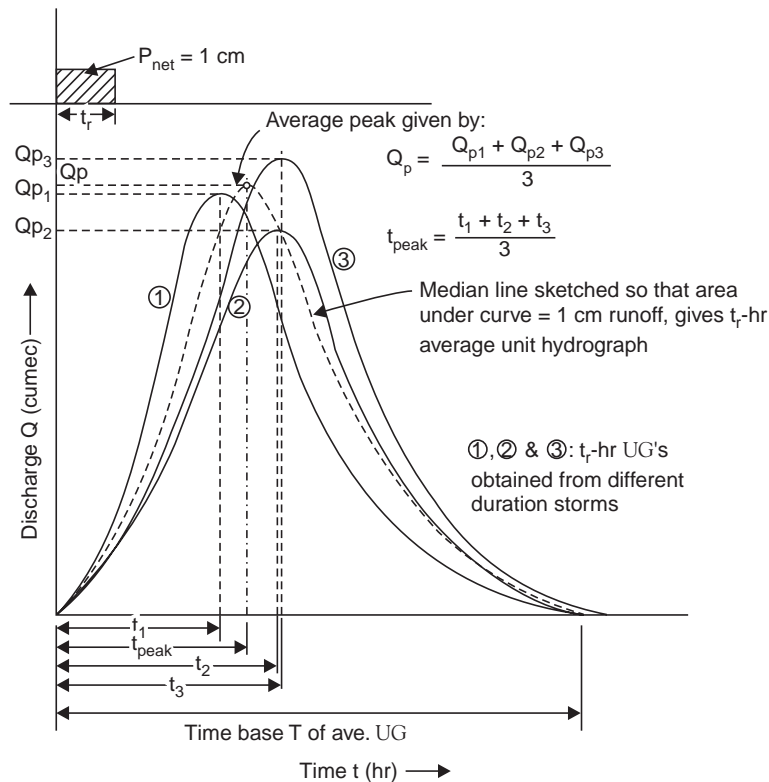

Fig. 5.16 Average unit hydrograph

Alteration of Unit Hydrograph Duration. It becomes necessary, in computation of flood hydrographs, that the duration of the unit graph available should be altered to suit the duration of the design storm (to be used for obtaining the flood hydrograph). Two cases arise:

Case (i) *Changing a Short Duration Unit Hydrograph to Longer Duration.* If the desired long duration of the unit graph is an even multiple of the short, say a 3-hour unit graph is given and a 6-hour unit graph is required. Assume two consecutive unit storms, producing a net rain of 1 cm each. Draw the two unit hydrographs, the second unit graph being lagged by 3 hours. Draw now the combined hydrograph by superposition. This combined hydrograph will now produce 2 cm in 6 hours. To obtain the 6-hour unit graph divide the ordinates of the combined hydrograph by 2, Fig. 5.17. It can be observed that this 6-hour unit graph derived has a longer time base by 3 hours than the 3-hour unit graph, because of a lower intensity storm for a longer time.

Example 5.3 *The following are the ordinates of a 3-hour unit hydrograph. Derive the ordinates of a 6-hour unit hydrograph and plot the same.*

| <i>Time (hr)</i> | <i>3-hr UGO (cumec)</i> | <i>Time (hr)</i> | <i>3-hr UGO (cumec)</i> |
|------------------|-----------------------------|------------------|-----------------------------|
| 0 | 0 | 15 | 9.4 |
| 3 | 1.5 | 18 | 4.6 |
| 6 | 4.5 | 21 | 2.3 |
| 9 | 8.6 | 24 | 0.8 |
| 12 | 12.0 | | |

Solution

Table 5.3 Derivation of the 6-hour unit hydrograph. (Example 5.3)

| <i>Time (hr)</i> | <i>3-hr UGO (cumec)</i> | <i>3-hr UGO (logged) (cumec)</i> | <i>Total (2) + (3) (cumec)</i> | <i>6-hr UGO (4) ÷ 2 (cumec)</i> |
|----------------------|---------------------------------|--|--|---|
| <i>1</i> | <i>2</i> | <i>3</i> | <i>4</i> | <i>5</i> |
| 0 | 0 | | 0 | 0 |
| 3 | 1.5 | 0 | 1.5 | 0.7 |
| 6 | 4.5 | 1.5 | 6.0 | 3.0 |
| 9 | 8.6 | 4.5 | 13.1 | 6.5 |
| 12 | 12.0 | 8.6 | 20.6 | 10.3 |
| 15 | 9.4 | 12.0 | 21.4 | 10.7 |
| 18 | 4.6 | 9.4 | 14.0 | 7.0 |
| 21 | 2.3 | 4.6 | 6.9 | 3.4 |
| 24 | 0.8 | 2.3 | 3.1 | 1.5 |
| 27 | | 0.8 | 0.8 | 0.4 |

The 6-hour unit graph derived as above is shown in Fig. 5.17.

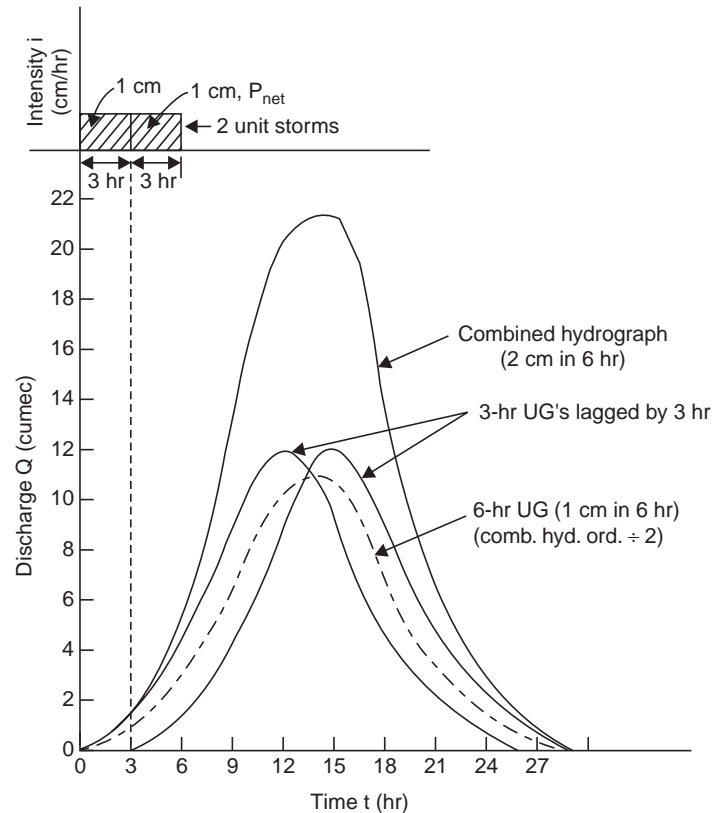

Fig. 5.17 Changing a short duration UG to a long multiple duration

Case (ii) Changing a Long Duration Unit Hydrograph to a Shorter Duration by S-curve Technique

5.6 S-CURVE METHOD

S-curve or the summation curve is the hydrograph of direct surface discharge that would result from a continuous succession of unit storms producing 1 cm in t_r -hr (Fig. 5.18). If the time base of the unit hydrograph is T hr, it reaches constant outflow (Q_e) at T hr, since 1 cm of net rain on the catchment is being supplied and removed every t_r hour and only T/t_r unit graphs are necessary to produce an S-curve and develop constant outflow given by,

$$Q_e = \frac{2.78 A}{t_r} \quad \dots(5.6)$$

where Q_e = constant outflow (cumec)

t_r = duration of the unit graph (hr)

A = area of the basin (km^2)

Given a t_r -hour unit graph, to derive a t'_r -hour unit graph ($t'_r \geq t_r$)—Shift the S-curve by the required duration t'_r along the time axis. The graphical difference between the ordinates of the two S-curves, i.e., the shaded area in Fig. 5.18 represents the runoff due to t'_r hours rain at

an intensity of $1/t_r$ cm/hr, i.e., runoff of t_r'/t_r cm in t_r' hours. To obtain a runoff of 1 cm in t_r' hours (i.e., t_r' -hour UG), multiply the ordinates of the S-curve difference by t_r/t_r' . This technique may be used to alter the duration of the given unit hydrograph to a shorter or longer duration. The longer duration need not necessarily be a multiple of short.

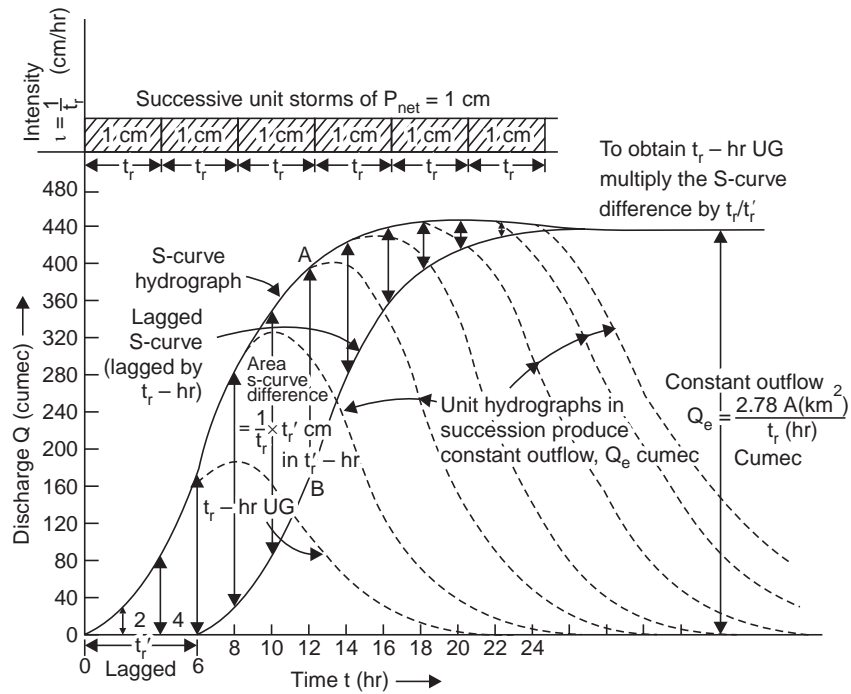

Fig. 5.18 Changing the duration of UG by S-curve technique (Example 5.5)

Example 5.4 The ordinates of a 4-hour unit hydrograph for a particular basin are given below. Derive the ordinates of (i) the S-curve hydrograph, and (ii) the 2-hour unit hydrograph, and plot them, area of the basin is 630 km^2 .

| Time (hr) | Discharge (cumec) | Time (hr) | Discharge (cumec) |
|-----------|-------------------|-----------|-------------------|
| 0 | 0 | 14 | 70 |
| 2 | 25 | 16 | 30 |
| 4 | 100 | 18 | 20 |
| 6 | 160 | 20 | 6 |
| 8 | 190 | 22 | 1.5 |
| 10 | 170 | 24 | 0 |
| 12 | 110 | | |

Solution See Table 5.4

Table 5.4 Derivation of the S-curve and 2-hour unit hydrographs. (Example 5.4)

| Time (hr) | 4-hr UGO (cumec) | S-curve additions (cumec) | | S-curve ordinates (cumec) (2) + (3) | lagged S-curve (cumec) | S-curve difference (cumec) (4) - (5) | 2-hr UGO (6) × 4/3 (cumec) |
|--------------|---------------------|---|-----|--|------------------------------|---|----------------------------------|
| 1 | 2 | 3 | | 4 | 5 | 6 | 7 |
| | | (unit storms after every 4 hr = t_r) | | | | | |
| 0 | 0 | — | — | 0 | — | 0 | 0 |
| 2 | 25 | — | — | 25 | 0 | 25 | 50 |
| 4 | 100 | 0 | — | 100 | 25 | 75 | 150 |
| 6 | 160 | 25 | — | 185 | 100 | 85 | 170 |
| 8 | 190 | 100 | 0 | 290 | 185 | 105 | 210 |
| 10 | 170 | 160 | 25 | 335 | 290 | 65 | 130 |
| 12 | 110 | 190 | 100 | 400 | 355 | 45 | 90 |
| 14 | 70 | 170 | 160 | 425 | 400 | 25 | 50 |
| 16 | 30 | 110 | 190 | 430 | 425 | 5 | 10* |
| 18 | 20 | 70 | 170 | 445 | 430 | 15 | 30 |
| 20 | 6 | 30 | 110 | 436 | 445 | -9 | -18* |
| 22 | 1.5 | 20 | 70 | 446.5 | 436 | 10.5 | 21 |
| 24 | 0 | 6 | 30 | 436 | 446.6 | -10.5 | -21* |

*Slight adjustment is required to the tail of the 2-hour unit hydrograph.

Col (5): lagged S-curve is the same as col (4) but lagged by $t_r' = 2$ hr.

Col (7): $\text{col (6)} \times \frac{t_r}{t_r'} = 4 \text{ hr. } t_r' = 2 \text{ hr.}$

Col (3): No. of unit storms in succession = $T/t_r = 24/4 = 6$, to produce a constant outflow.

$$Q_e = \frac{2.78 A}{t_r} = \frac{2.78 \times 630}{4} = 437 \text{ cumec, which agrees very well with the tabulated S-curve terminal value of 436. The S-curve additions can be written in one column, without having to write in 5 columns successively lagged by 4 hours (= } t_r), \text{ as is illustrated in the example 5.5.}$$

Plot col (4) versus col (1) to get the S-curve hydrograph, and col (7) versus col (1) to get the 2-hour unit hydrograph, as shown in Fig. 5.19.

Example 5.5 The ordinates of a 4-hour unit hydrograph for a particular basin are given below. Determine the ordinates of the S-curve hydrograph and therefrom the ordinates of the 6-hour unit hydrograph.

| Time (hr) | 4-hr UGO (cumec) | Time (hr) | 4-hr UGO (cumec) |
|-----------|------------------|-----------|------------------|
| 0 | 0 | 12 | 110 |
| 2 | 25 | 14 | 70 |
| 4 | 100 | 16 | 30 |
| 6 | 160 | 18 | 20 |
| 8 | 190 | 20 | 6 |
| 10 | 170 | 22 | 1.5 |
| | | 24 | 0 |

Solution See Table 5.5.

Table 5.5 Derivation of the 6-hour UG for the basin (Example 5.5)

| Time (hr) | 4-hour UGO (cumec) | S-curve ¹ additions (cumec) | S-curve ordinates (cumec) (2) + (3) | lagged ² C-curve (cumec) | S-curve difference (cumec) (4) - (5) | 6-hr UGO (cumec) (6) × 4/6 |
|-----------|--------------------|--|-------------------------------------|-------------------------------------|--------------------------------------|----------------------------|
| 1 | 2 | 3 | 4 | 5 | 6 | 7 |
| 0 | 0 → | — | 0 | — | 0 | 0 |
| 2 | 25 → | — | 25 | — | 25 | 16.7 |
| 4 | 100 + → | 0 | 100 | — | 100 | 66.7 |
| 6 | 160 + → | 25 | 185 | 0 | 185 | 123.3 |
| 8 | 190 | 100 | 290 | 25 | 265 | 176.7 |
| 10 | 170 | 185 | 355 | 100 | 255 | 170.0 |
| 12 | 110 | 290 | 400 | 185 | 215 | 143.3 |
| 14 | 70 | 355 | 425 | 290 | 135 | 90.0 |
| 16 | 30 | 400 | 430 | 355 | 75 | 50.0 |
| 18 | 20 | 425 | 445 | 400 | 45 | 30.0 |
| 20 | 6 | 430 | 436 | 425 | 11 | 7.3 |
| 22 | 1.5 | 445 | 446.6 | 430 | 16.5 | 11.0 |
| 24 | 0 | 436 | 436 | 445 | -9 | -6.0 |

1—Start the operation shown with 0 cumec after $t_r = 4$ hr.

2—Lag the S-curve ordinates by $t_r' = 6$ hr.

Plot col (4) vs. col (1) to get S-curve hydrograph and col (7) vs. col (1) to get 6-hr unit hydrograph as shown in Fig. 5.19.

5.7 BERNARD'S DISTRIBUTION GRAPH

The distribution graph, introduced by Bernard in 1935, shows the percentages of total unit hydrograph, which occur during successive, arbitrarily chosen, uniform time increments, Fig. 5.20. It is an important concept of the unit hydrograph theory that all unit storms, regardless of their intensity, produce nearly identical distribution graphs.

The procedure of deriving the distribution graph is first to separate the base flow from the total runoff; the surface runoff obtained is divided into convenient time units, and the average rate of surface runoff during each interval is determined.

If the rainfall-runoff data for a short duration fairly uniform storm is known, the duration of net rainfall is taken as the unit period and the distribution percentages are computed directly. But if there are multiple storms of different intensities producing different net rains during successive unit periods, a trial and error procedure of applying the distribution percentages is followed, till the direct surface runoff during successive time intervals corresponds to the computed values. Once a distribution graph is derived for a drainage basin, any expected volume of surface runoff from the basin can be converted into a discharge hydrograph. By drawing a smooth curve along the steps of the distribution graph to give equal areas, a unit hydrograph may be obtained as shown in Fig. 5.20.

Example 5.6 Analysis of the runoff records for a one day unit storm over a basin yields the following data:

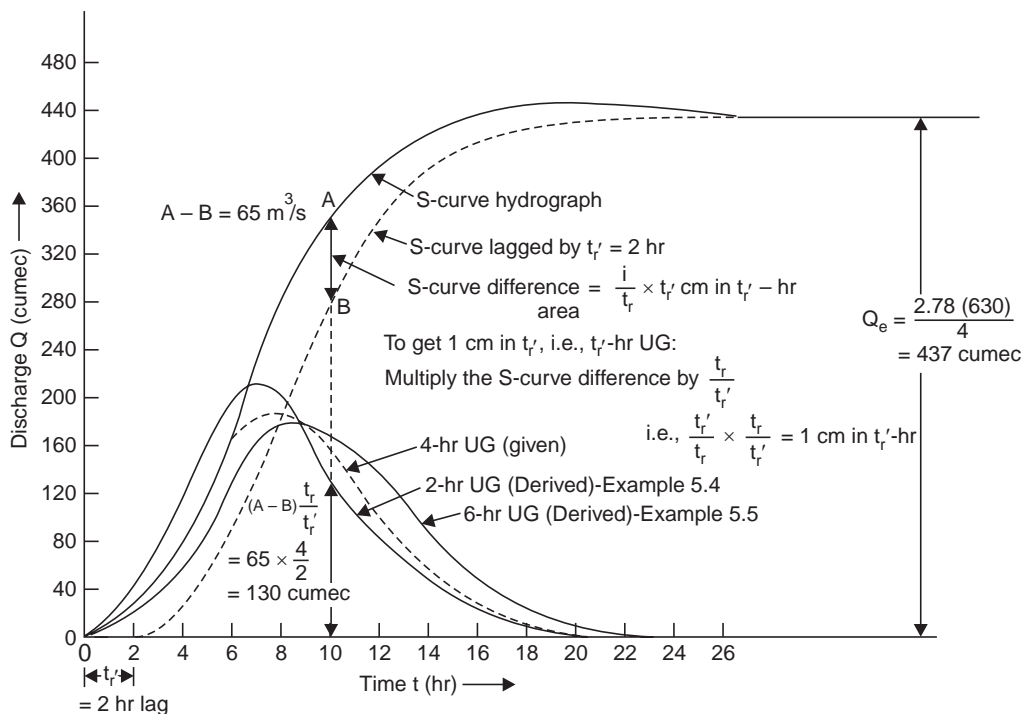

Fig. 5.19 Derivation of 2-hr & 6-hr UG from a 4-hr UG (Example 5.4 & 5.5)

Total stream flow at concentration point on successive days are 19.6, 62.4, 151.3, 133.0, 89.5, 63.1, 43.5, 28.6, and 19.6 cumec.

Estimated base flow during the corresponding period on successive days are 19.6, 22.4, 25.3, 28.0, 28.0, 27.5, 25.6, 22.5 and 19.6 cumec.

Determine the distribution graph percentages.

On the same basin (area = 2850 km²) there was rainfall of 7 cm/day on July 15 and 10 cm/day on July 18 of a certain year. Assuming an average storm loss of 2 cm/day, estimate the value of peak surface runoff in cumec and the date of its occurrence.

Table 5.6 Derivation of distribution percentages

| Day since beginning of direct runoff | DRO on mid-day (cumec) | Percentage of ΣDRO | Remarks |
|--------------------------------------|------------------------|----------------------------|-------------------------------|
| 1 | 2 | 3 | 4 |
| 1 | 18 | 4.5 | $= \frac{18}{402} \times 100$ |
| 2 | 96 | 24 | |
| 3 | 120 | 30 | |
| 4 | 82 | 20 | |
| 5 | 47 | 12 | |
| 6 | 25 | 6 | |
| 7 | 12 | 3 | |
| 8 | 2 | 0.5 | |
| 8 equal time (i.e., a day) intervals | $\Sigma DRO = 402$ | Total = 100.0 | |

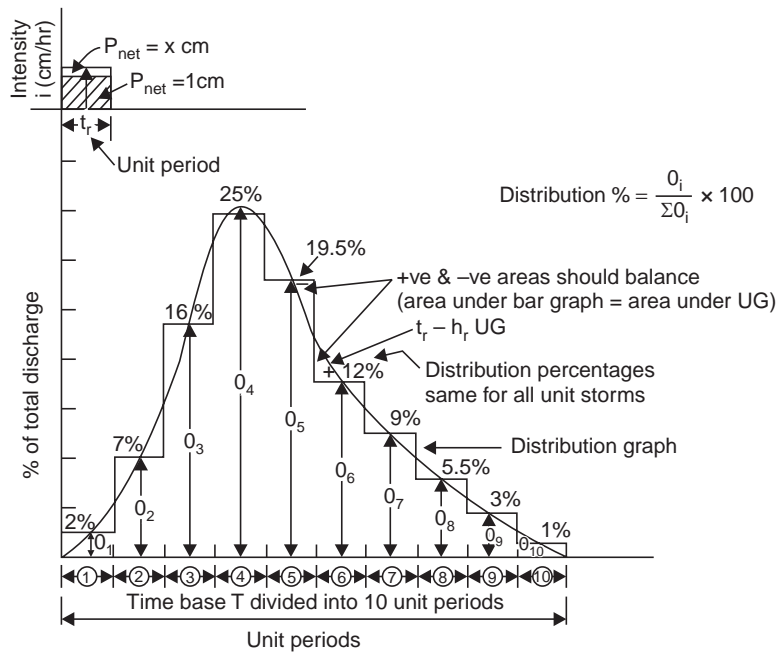

Fig. 5.20 Distribution graph (after Bernard, 1935)

Solution The total runoff hydrograph and estimated base flow are drawn in Fig. 5.21 and the direct runoff ordinates on successive mid-days are determined as $DRO = TRO - BFO$ and the percentages of direct runoff on successive days computed in Table 5.6. Column (3) gives the distribution percentages, and the derived distribution graph for 1-day unit storms is shown in Fig. 5.22.

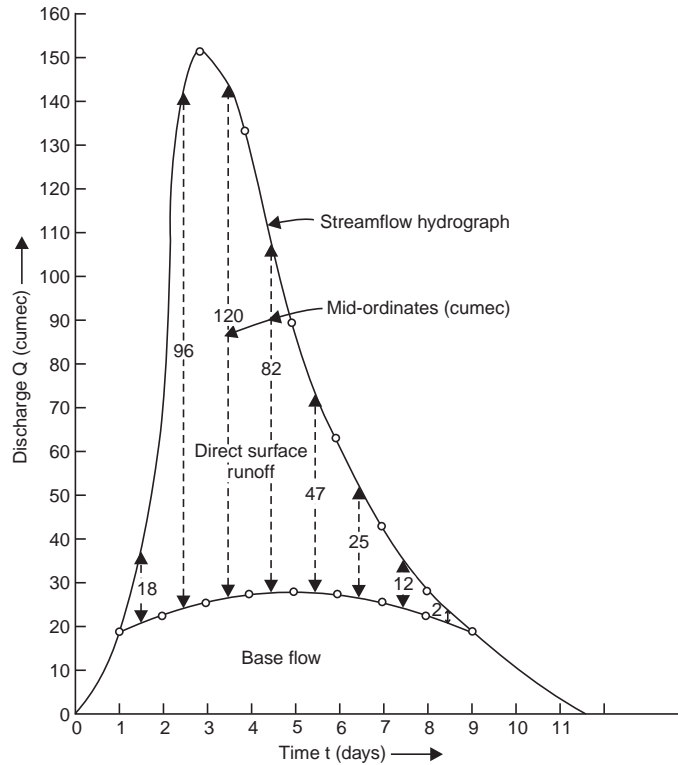

Fig. 5.21 Stream flow hydrograph (Example 5.6)

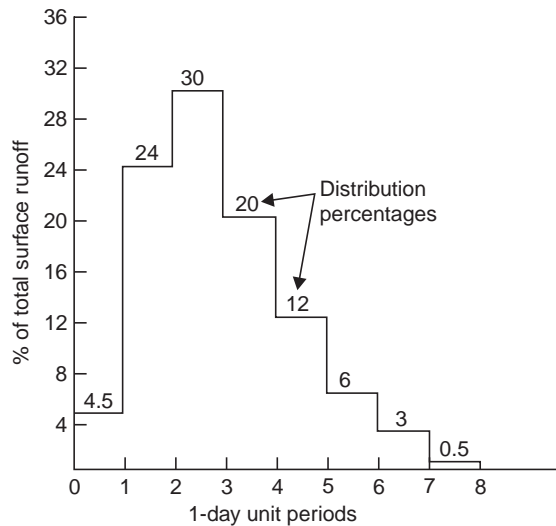

Fig. 5.22 Derived distribution graph (Example 5.6)

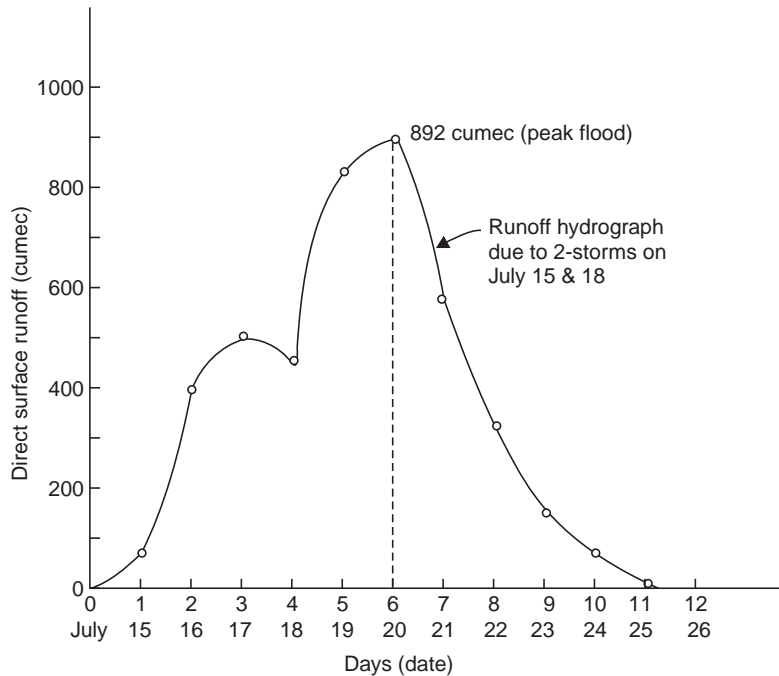

Fig. 5.23 Runoff Hydrograph (Example 5.6)

Applying the distribution percentages computed in col. (3) above the direct surface discharge on successive days due to the two storms (lagged by 3 days) is computed in Table 5.7

$$1 \text{ cm/day} = \frac{1}{100} \times \frac{2850 \times 10^6}{24 \times 60 \times 60} = 330 \text{ cumec}$$

The peak surface runoff is 892 cumec and occurs on July 20 of the year. The flood hydrograph is shown in Fig. 5.23.

Example 5.7 Analysis of rainfall and runoff records for a certain storm over a basin (of area 3210 km²) gave the following data:

Rainfall for successive 2 hr periods: 2.5, 6.5 and 4.5 cm/hr.

An average loss of 1.5 cm/hr can be assumed.

Direct surface discharge at the concentration point for successive 2-hr periods: 446, 4015, 1382, 25000, 20520, 10260, 4900 and 1338 cumec.

Derive the unit hydrograph in the form of distribution percentages on the basis 2-hr unit periods.

Solution The rainfall may be considered for three unit periods of 2 hr each, then from Fig. 5.24,

$$T_{DSR} = t_R + T_r \tag{5.7}$$

$$T = t_r + T_r \tag{5.7 a}$$

$$\begin{aligned} \therefore T &= t_r + T_{DSR} - t_R \\ &= 2 + 8 \times 2 - 3 \times 2 \end{aligned} \tag{5.7 b}$$

$$\therefore T = 12 \text{ hr}$$

Table 5.7 Application of distribution percentages to compute the direct surface discharge (Example 5.6)

| | | <i>Unit periods (day)</i> | | | | | | | | | | |
|-----------------------|-----|---------------------------|------|------|------|------|------|------|-------|------|------|------------------|
| | | 1 | 2 | 3 | 4 | 5 | 6 | 7 | 8 | 9 | 10 | 11 |
| Total rainfall (cm) → | | 7 | | | 10 | | | | | | | |
| Loss of rain (cm) → | | 2 | | | 2 | | | | | | | |
| Net rain (cm) → | | 5 | | | 8 | | | | | | | |
| | | | | | | | | | | | | (= 13 cm) |
| Unit distribution | | | | | | | | | | | | |
| Periods Percentages | | | | | | | | | | | | |
| 1 | 4.5 | 0.225 | | | 0.36 | | | | | | | |
| 2 | 24 | | 1.20 | | 1.92 | | | | | | | |
| 3 | 30 | | | 1.50 | | 2.40 | | | | | | |
| 4 | 20 | | | | 1.00 | | 1.60 | | | | | |
| 5 | 12 | | | | | 0.60 | | 0.96 | | | | |
| 6 | 6 | | | | | | 0.30 | | 0.48 | | | |
| 7 | 3 | | | | | | | 0.15 | | 0.24 | | |
| 8 | 0.5 | | | | | | | | 0.025 | | 0.04 | |
| Total (cm/day): | | 0.225 | 1.20 | 1.50 | 1.36 | 2.52 | 2.70 | 1.75 | 0.985 | 0.48 | 0.24 | 0.04 = 13 cm |
| × 330 = cumec: | | 74 | 396 | 495 | 450 | 833 | 892 | 578 | 325 | 158 | 79 | 13 (0.225 × 330) |
| | | | | | | | | | | | | = 74 cumec) |
| Date: July | | 15 | 16 | 17 | 18 | 19 | 20 | 21 | 22 | 23 | 24 | 25 |

The base width is 12 hr or 6 unit periods. As a first trial, try a set of six distribution percentages of 10, 20, 40, 15, 10, 5 which total 100%. The direct surface discharge can be converted into cm/hr as

$$1 \text{ cm/hr} = \frac{1}{100} \times \frac{3210 \times 10^6}{60 \times 60} = 8920 \text{ cumec}$$

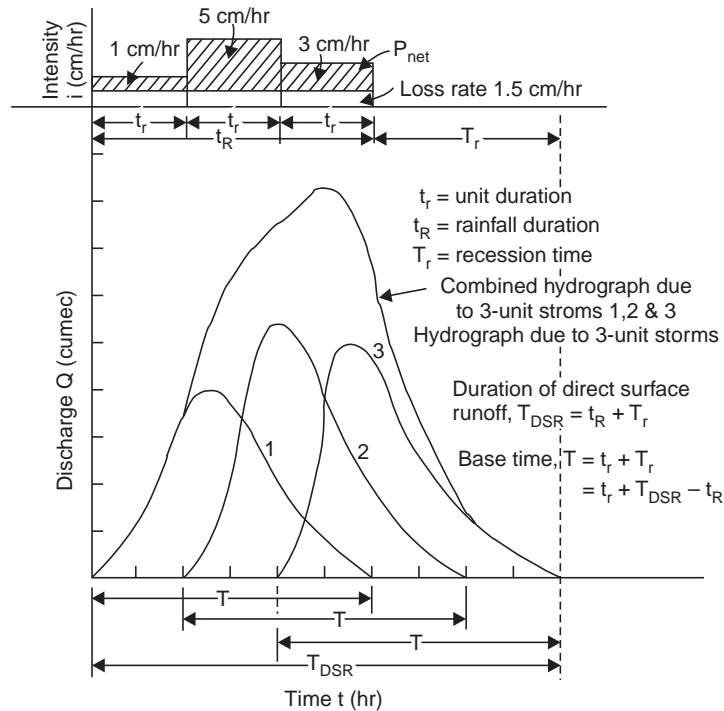

Fig. 5.24 Combined hydrograph (Example 5.7)

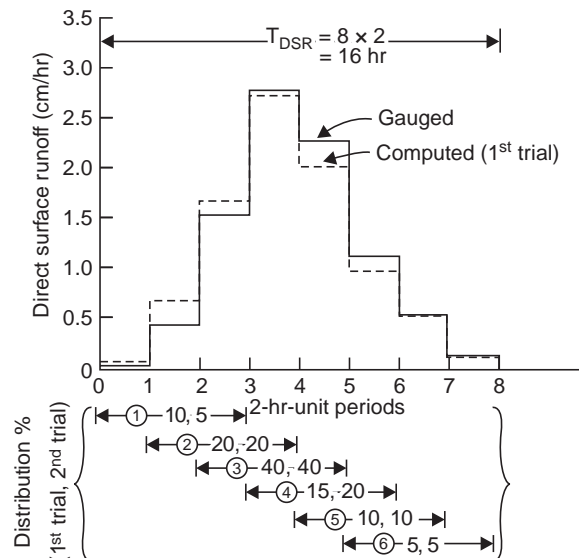

Fig. 5.25 Derivation of distribution percentages (Example 5.7)

Table 5.8 Derivation of distribution percentages by trials (Example 5.7)

| | | <i>2-hr-unit periods</i> | | | | | | | |
|-------------------------|---------|--------------------------|--------|----------------|--------|--------|--------|------|------------------------------|
| | | 1 | 2 | 3 | 4 | 5 | 6 | 7 | 8 |
| Rainfall rate (cm/hr) → | | 2.5 | 6.5 | 4.5 | | | | | |
| Loss rate (cm/hr) → | | 1.5 | 1.5 | 1.5 | | | | | |
| Net rain (cm/hr) → | | 1 | 5 | 3 (= 9 × 2 cm) | | | | | |
| Unit distribution | | | | | | | | | |
| Periods Percentage | | | | | | | | | |
| 1 | 10 (5) | (0.05) | (0.25) | (0.15) | | | | | |
| | | 0.10 | 0.50 | 0.30 | | | | | |
| 2 | 20 | | 0.20 | 1.00 | 0.60 | | | | |
| 3 | 40 | | | 0.40 | 2.00 | 1.20 | | | |
| 4 | 15 (20) | | | | (0.20) | (1.00) | (0.60) | | |
| | | | | | 0.15 | 0.75 | 0.45 | | |
| 5 | 10 | | | | | 0.10 | 0.50 | 0.30 | |
| 6 | 5 | | | | | | 0.05 | 0.25 | 0.15 |
| Total 100 (100) cm/hr | | 0.10 | 0.70 | 1.70 | 2.75 | 2.05 | 1.00 | 0.55 | 0.15 (= 9 × 2 cm check) |
| | | (0.05) | (0.45) | (1.55) | (2.80) | (2.30) | (1.15) | | |
| cumec | | 446 | 4015 | 1382 | 25000 | 20520 | 10260 | 4900 | 1338 (446/8920 = 0.05 cm/hr) |

Note Figures in brackets indicate the adjusted values in the second trial.

and the direct surface runoff for successive 2-hr periods are 0.05, 0.45, 1.55, 2.80, 2.30, 1.15, 0.55, and 0.15 cm/hr. The first trial hydrograph computed in Table 5.8 is shown by dashed lines in Fig. 5.25 for comparison and selection of the distribution percentages for the second trial. The first percentage affects the first 3 unit periods, the second percentage affects the 2nd, 3rd and 4th unit periods and like that. Since the first trial hydrograph gives higher values (than gauged) for the first three unit periods, a lower percentage of 5 (instead of 10%) is tried. Similarly, the other percentages are adjusted till the computed discharge values agree with the gauged values. Thus, the second trial distribution percentages are 5, 20, 40, 20, 10, 5 which total 100 and are final and the distribution graph thus derived is shown in Fig. 5.26. In most cases, more trials are required to obtain the desired degree of accuracy.

Also see Appendix—G.

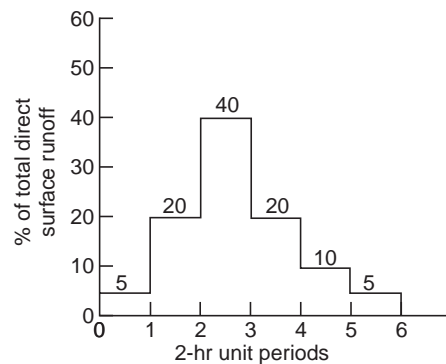

Fig. 5.26 Derived distribution graph (Example 5.7)

5.8 INSTANTANEOUS UNIT HYDROGRAPH

The difficulty of using a unit hydrograph of a known duration has been obviated by the development of the instantaneous unit hydrograph (IUH). The IUH is a hydrograph of runoff resulting from the instantaneous application of 1 cm net rain on the drainage basin. The IUH in conjunction with the design storm can be used to obtain the design flood by using a convolution integral. The IUH was first proposed by Clark in 1945. The IUH can be developed either directly from the observed data or by adopting conceptual models [see Chapter-16 & 17 for Methods of Determining IUH].

5.9 SYNTHETIC UNIT HYDROGRAPHS

In India, only a small number of streams are gauged (*i.e.*, streamflows due to single and multiple storms, are measured). There are many drainage basins (catchments) for which no streamflow records are available and unit hydrographs may be required for such basins. In such cases, hydrographs may be synthesised directly from other catchments, which are hydrologically and meteorologically homogeneous, or indirectly from other catchments through the application of empirical relationship. Methods for synthesising hydrographs for ungauged areas have been developed from time to time by Bernard, Clark, McCarthy and Snyder. The best known approach is due to Snyder (1938). Snyder analysed a large number of hydrographs from drainage basins in the Appalachian Mountain region in USA ranging in the area from 25 to 25000 km² and selected the three parameters for the development of unit hydrograph, namely,

base width (T), peak discharge (Q_p) and lag time (basin lag, t_p), Fig. 5.27, and proposed the following empirical formulae for the three parameters:

Lag time,
$$t_p = C_t (L L_{ca})^{0.3} \quad \dots(5.8)$$

standard duration of net rain,
$$t_r = \frac{t_p}{5.5} \quad \dots(5.9)$$

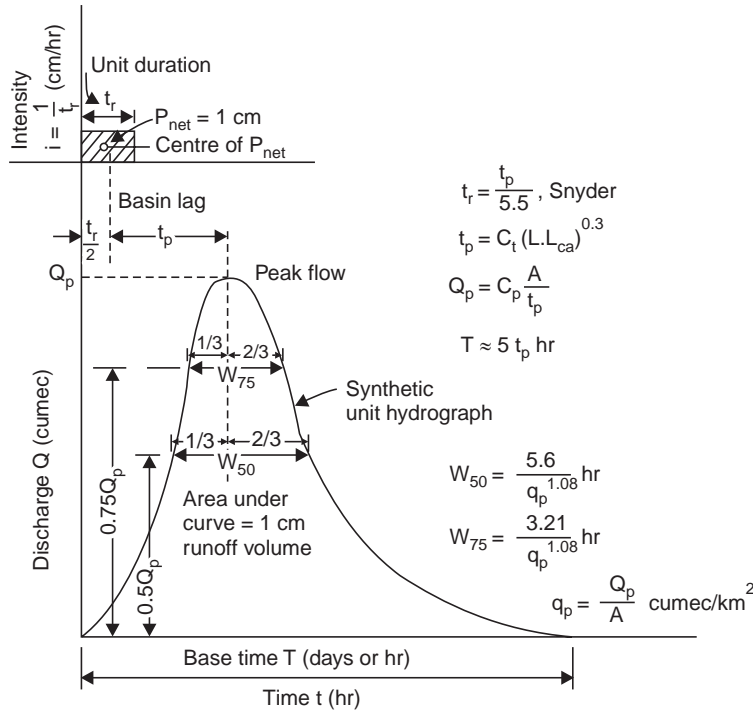

Fig. 5.27 Synthetic unit hydrograph parameters

For this standard duration of net rain,

peak flow,
$$Q_p = C_p \frac{A}{t_p} \quad \dots(5.10)$$

time base in days,
$$T = 3 + 3 \left(\frac{t_p}{24} \right) \quad \dots(5.11)$$

peak flow per km² of basin,
$$q_p = \frac{Q_p}{t_p} \quad \dots(5.12)$$

Snyder proposed subsequently an expression to allow for some variation in the basin lag with variation in the net rain duration, *i.e.*, if the actual duration of the storm is not equal to t_r , given by Eq. (5.9) but is t'_r , then

$$t_{pr} = t_p + \frac{t'_r - t_r}{4} \quad \dots(5.13)$$

where t_{pr} = basin lag for a storm duration of t'_r , and t_{pr} is used instead of t_p in Eqs. (5.10), (5.11) and (5.12).

In the above equations,

t_p = lag time (basin lag), hr

C_p, C_p = empirical constants ($C_t \approx 0.2$ to 2.2 , $C_p \approx 2$ to 6.5 , the values depending on the basin characteristics and units)

A = area of the catchment (km^2)

L = length of the longest water course, *i.e.*, of the mainstream from the gauging station (outlet or measuring point) to its upstream boundary limit of the basin, (km) (Fig. 5.28)

L_{ca} = length along the main stream from the gauging station (outlet) to a point on the stream opposite the areal centre of gravity (centroid) of the basin

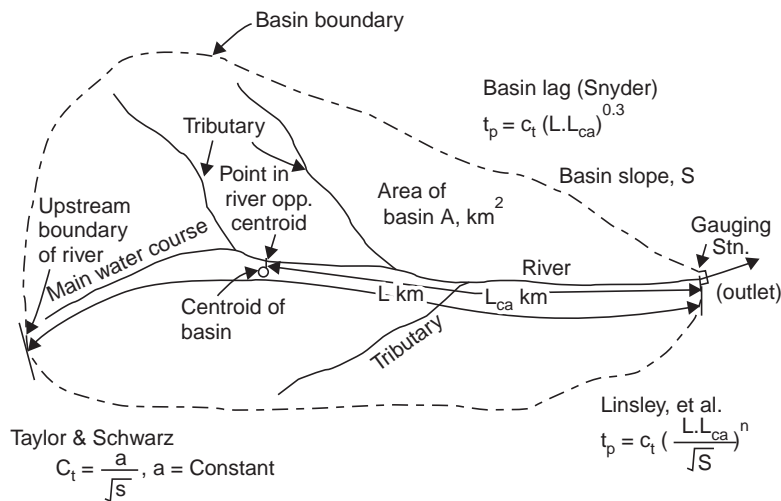

Fig. 5.28 Basin characteristics (Snyder)

Snyder considered that the shape of the unit hydrograph is likely to be affected by the basin characteristics like area, topography, shape of the slope, drainage density and channel storage. He dealt with the size and shape of basin by measuring the length of the mainstream channel. The coefficient C_t reflects the size, shape and slope of the basin.

Linsley, Kohler and Paulhus gave an expression for the lag time in terms of the basin characteristics (see Fig. 5.31) as

$$t_p = C_t \left(\frac{L L_{ca}}{\sqrt{S}} \right)^n \quad \dots(5.14)$$

where S = basin slope, and the values of n and C_t , when L, L_{ca} were measured in miles are

- $n = 0.38$
- $C_t = 1.2$, for mountainous region
- $= 0.72$, for foot hill areas
- $= 0.35$, for valley areas

Taylor and Scwarz found from an analysis of 20 drainage basins of size 50-4000 km^2 in the north and middle Atlantic States in USA that (when L and L_{ca} were measured in miles)

$$C_t = \frac{0.6}{\sqrt{S}} \quad \dots(5.15)$$

$$\text{Time base in hr,} \quad T = 5 \left(t_{pr} + \frac{t'_r}{2} \right) \quad \dots(5.16)$$

$$\text{i.e.,} \quad T = 5 \times t_{\text{peak}} \quad \dots(5.16 a)$$

The usual procedure for developing a synthetic unit hydrograph for a basin for which the streamflow records are not available is to collect the data for the basin like A , L , L_{ca} and to get the coefficients, C_t and C_p from adjacent basins whose streams are gauged and which are hydrometeorologically homogeneous. From these the three parameters, i.e., the time to peak, the peakflow and the time base are determined from the Snyder's empirical equations, and the unit hydrograph can be sketched so that the area under the curve is equal to a runoff volume of 1 cm. Empirical formulae have been developed by the US Army Corps of Engineers (1959) for the widths of W_{50} and W_{75} of the hydrograph in hours at 50% and 75% height of the peak flow ordinate, respectively, (see Fig. 5.29) as

$$W_{50} = \frac{5.6}{q_p^{1.08}} \quad \dots(5.17)$$

$$W_{75} = \frac{3.21}{q_p^{1.08}} = \frac{W_{50}}{1.75} \quad \dots(5.18)$$

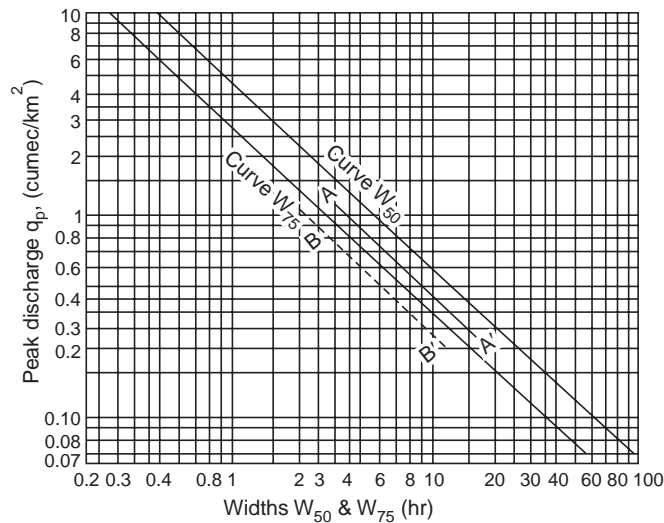

Fig. 5.29 Widths W_{50} and W_{75} for synthetic UG (US Army, 1959)

A still better shape of the unit hydrograph can be sketched with these widths (Fig. 5.27). The base time T given by Eq. (5.11) gives a minimum of 3 days even for very small basins and is in much excess of delay attributable to channel storage. In such cases, the author feels T given by Eq. (5.16 a) may be adopted and the unit hydrograph sketched such that the area under the curve gives a runoff volume of 1 cm.

Synthetic unit hydrographs for a few basins in India have been developed by CWPC.

Example 5.8 The following are the ordinates of the 9-hour unit hydrograph for the entire catchment of the river Damodar up to Tenughat dam site:

| | | | | | | | | | | | |
|---------------------|---|----|------|-----|-----|----|----|----|----|----|----|
| Time (hr): | 0 | 9 | 18 | 27 | 36 | 45 | 54 | 63 | 72 | 81 | 90 |
| Discharge (cumeck): | 0 | 69 | 1000 | 210 | 118 | 74 | 46 | 26 | 13 | 4 | 0 |

and the catchment characteristics are

$$A = 4480 \text{ km}^2, L = 318 \text{ km}, L_{ca} = 198 \text{ km}$$

Derive a 3-hour unit hydrograph for the catchment area of river Damodar up to the head of Tenughat reservoir, given the catchment characteristics as:

$$A = 3780 \text{ km}^2, L = 284 \text{ km}, L_{ca} = 184 \text{ km}$$

Use Snyder's approach with necessary modifications for the shape of the hydrograph.

Solution The 9-hr UG is plotted in Fig. 5.30 and from that $t_p = 13.5$ hr

$$t_r = 9 \text{ hr}, \quad \frac{t_p}{5.5} = \frac{13.5}{5.5} = 2.46 \text{ hr} \neq t_r \text{ of } 9 \text{ hr}$$

\therefore $t_r' = 9 \text{ hr}, t_{pr} = 13.5 \text{ hr}$ and t_p has to be determined

$$t_{pr} = t_p + \frac{t_r' - t_r}{4}$$

$$13.5 = t_p + \frac{9 - t_p/5.5}{4}$$

$$\therefore \quad t_p = 11.8 \text{ hr}$$

$$t_p = C_t (LL_{ca})^{0.3}$$

$$11.8 = C_t (318 \times 198)^{0.3}$$

$$\therefore \quad C_t = 0.43$$

$$\text{Peak flow, } Q_p = C_p \frac{A}{t_{pr}}$$

$$1000 = C_p \frac{4480}{13.5}$$

$$\therefore \quad C_p = 3.01, \text{ say, } 3$$

The constants of $C_t = 0.43$ and $C_p = 3$ can now be applied for the catchment area up to the head of the Tenughat reservoir, which is meteorologically and hydrologically similar.

$$t_p = C_t (LL_{ca})^{0.3} = 0.43 (284 \times 184)^{0.3} = 11.24 \text{ hr}$$

$$\frac{t_p}{5.5} = \frac{11.24}{5.5} = 2.04 \text{ hr} \neq t_r \text{ of } 3 \text{ hr (duration of the required UG)}$$

\therefore $t_r' = 3 \text{ hr}, t_r = 2.04 \text{ hr}$ and t_{pr} has to be determined.

$$t_{pr} = t_p + \frac{t_r' - t_r}{4} = 11.24 + \frac{3 - 2.04}{4}$$

$$\therefore \quad t_{pr} = 11.48 \text{ hr, say, } \mathbf{11.5 \text{ hr}}$$

$$\text{Peak flow } Q_p = C_p \frac{A}{t_{pr}} = 3 \times \frac{3780}{11.5} = \mathbf{987 \text{ cumec}}$$

Time to peak from the beginning of rising limb

$$t_{\text{peak}} = t_{pr} + \frac{t_r'}{2} = 11.5 + \frac{3}{2} = \mathbf{13 \text{ hr}}$$

$$\text{Time base (Snyder's) } T \text{ (days)} = 3 + 3 \left(\frac{t_{pr}}{24} \right) = 3 + 3 \left(\frac{11.5}{24} \right) = 4.44 \text{ days or } 106.5 \text{ hr}$$

This is too long a runoff duration and hence to be modified as

$$T(\text{hr}) = 5 \times t_{\text{peak}} = 5 \times 13 = \mathbf{65 \text{ hr}}$$

To obtain the widths of the 3-hr UG at 50% and 75% of the peak ordinate :

$$q_p = \frac{Q_p}{A} = \frac{987}{3780} = 0.261 \text{ cumec/km}^2$$

$$W_{50} = \frac{5.6}{(q_p)^{1.08}} = \frac{5.6}{(0.261)^{1.08}} = \mathbf{23.8 \text{ hr}}$$

$$W_{75} = \frac{3.21}{(q_p)^{1.08}} = \frac{3.21}{(0.261)^{1.08}} = \mathbf{13.6 \text{ hr}} = \frac{23.8}{1.75}$$

These widths also seem to be too long and a 3-hr UG can now be sketched using the parameters $Q_p = 987$ cumec, $t_{\text{peak}} = 13$ hr and $T = 65$ hr such that the area under the UG is equal to a runoff volume of 1 cm, as shown in Fig. 5.30.

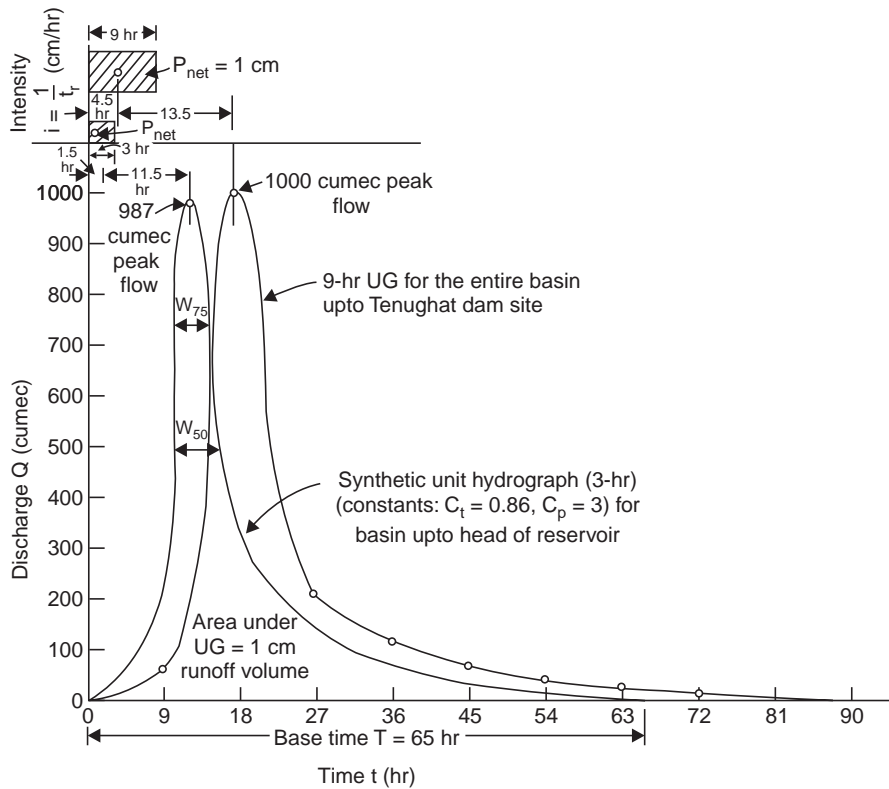

Fig. 5.30 Synthetic unit hydrograph derived (Example 5.8)

5.10 TRANSPOSING UNIT HYDROGRAPHS

From Eq. (5.14)

$$t_p = C_t \left(\frac{LL_{ca}}{\sqrt{S}} \right)^n$$

$$\underbrace{\log t_p}_{y} = \underbrace{\log C_t}_{c} + n \underbrace{\log \frac{LL_{ca}}{\sqrt{S}}}_{x}$$

$$y = c + m x$$

Hence, a plot of t_p vs. $\frac{LL_{ca}}{\sqrt{S}}$ on log-log paper from data from basins of similar hydrologic characteristics gives a straight-line relationship (Fig. 5.31). The constant $C_t = t_p$ when $\frac{LL_{ca}}{\sqrt{S}} = 1$, and the slope of the straight line gives n . It may be observed that for basins having different hydrologic characteristics the straight lines obtained are nearly parallel, *i.e.*, the values of C_t varies depending upon the slope of the basin (as can be seen from Eq. 5.15) but the value of n is almost same.

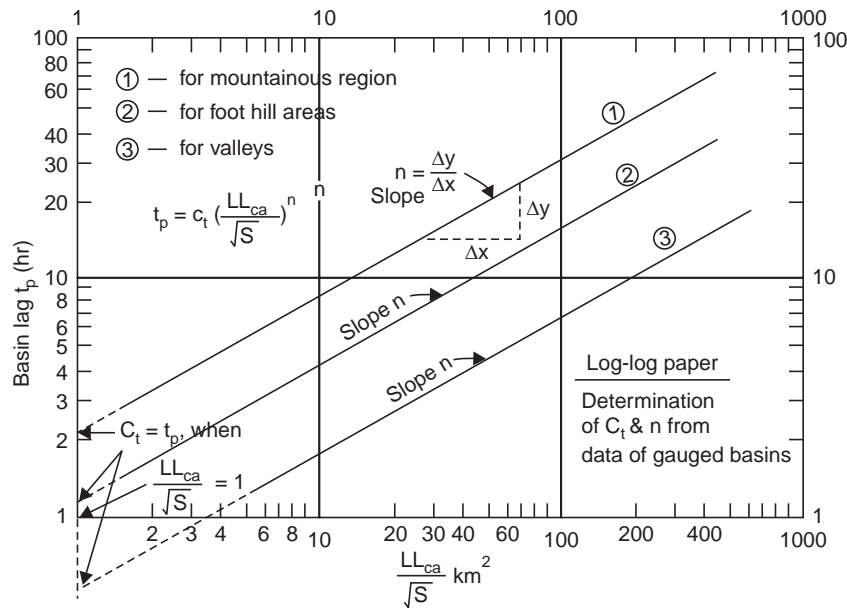

Fig. 5.31 Basin lag vs. basin characteristics

From a plot of q_p vs. t_p , or from dimensionless hydrographs from gauged basins, the peak flow and the shape of the unit hydrograph for ungauged basins can be estimated provided they are hydrometeorologically the same. The dimensionless unit hydrographs eliminates the effect of basin size and much of the effect of basin shape. Hence, it is a useful means for comparison of unit hydrographs of basins of different sizes and shapes or those resulting from different storm patterns. It can be derived from a unit hydrograph by reducing its time and discharge scales by dividing by t_p and Q_p , respectively. By averaging a number of dimensionless unit hydrographs of drainage areas, a representative dimensionless graph can be synthesized for a particular hydrological basin. A unit hydrograph for an ungauged basin, hydrologically similar, can be obtained directly from this dimensionless graph by multiplying by the appropriate values of t_p (obtained from log-log plot) and Q_p (from a plot of q_p vs. t_p).

Example 5.9 For the 9-hr UG given for the entire catchment of the river Damodar in Example 5.8, derive a dimensionless unit hydrograph.

Solution From example 5.8, $t_p = 11.8$ hr, $Q_p = 1000$ cumec, and hence the following computation can be made:

| | | | | | | | | | | | |
|-------------------|---|-------|-------|------|-------|-------|-------|-------|-------|-------|------|
| $\frac{t}{t_p}$: | 0 | 0.763 | 1.525 | 2.29 | 3.05 | 3.82 | 4.58 | 5.34 | 6.10 | 6.87 | 7.63 |
| $\frac{Q}{Q_p}$: | 0 | 0.069 | 1 | 0.21 | 0.118 | 0.074 | 0.046 | 0.026 | 0.013 | 0.004 | 0 |

The dimensionless unit hydrograph is plotted as shown in Fig. 5.32.

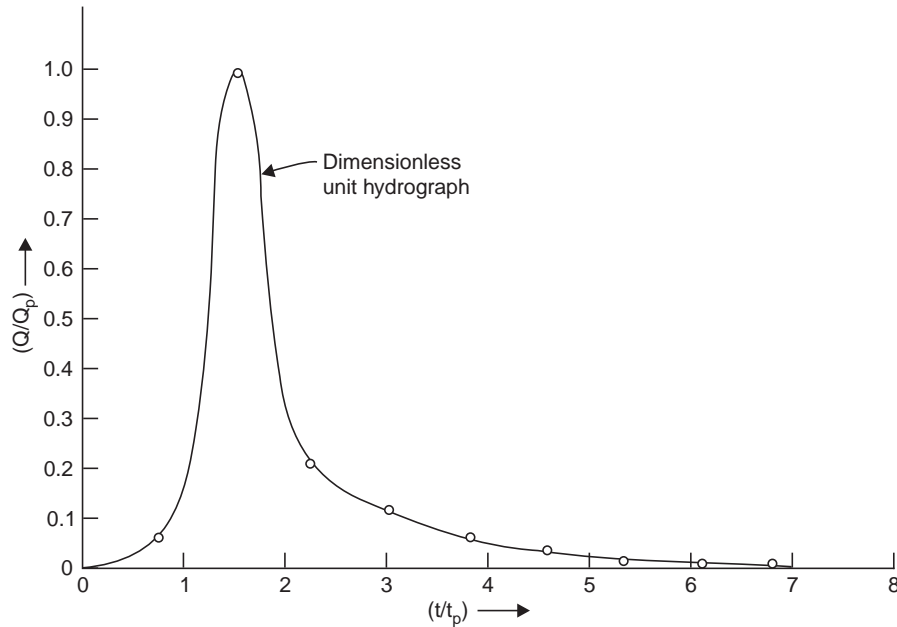

Fig. 5.32 Dimensionless unit hydrograph

The US Soil Conservation Service (1971), using many hydrographs from drainage areas of varying sizes and different geographical locations, has developed a dimensionless unit hydrograph and has developed the following formulae.

$$t_{\text{peak}} = \frac{t_c + 0.133 t_c}{1.7} \quad \text{and} \quad q_p = \frac{0.208 A Q}{t_{\text{peak}}}$$

where

t_c = time of concentration (hr)

t_{peak} = time to peak discharge from beginning (hr)

$$= \frac{t_r}{2} + t_p, \text{ where } t_p \text{ is lag time}$$

q_p = peak discharge (cumec)

A = drainage area (km^2)

Q = quantity of runoff, which is 1 mm for the unit hydrograph

Most hydrologists assume t_c as the time from the end of rainfall excess (P_{net}) to the point of inflection on the falling limb of the hydrograph; t_{peak} can be determined from t_c or lag time t_p (basin lag) for the required t_r -hr UG . From t_{peak} and known drainage area q_p can be determined. Once t_{peak} and q_p are obtained, 't vs. q' can be computed from the data of the dimensionless unit hydrograph and the UG can be sketched.

Example 5.9 (a) Construct a 4-hr UH for a drainage basin of 200 km² and lag time 10 hr by the SCS method, given ($pk = \text{peak}$):

| | | | | | | |
|----------------------|-----|---|------|-------|-------|-------|
| $\frac{t}{t_{pk}}$: | 0.5 | 1 | 2 | 3 | 4 | 5 |
| $\frac{Q}{Q_p}$: | 0.4 | 1 | 0.32 | 0.075 | 0.018 | 0.004 |

Solution $t_{pk} = \frac{t_r}{2} + t_p = \frac{4}{2} + 10 = 12 \text{ hr}$

(i) $Q_p = \frac{5.36 A}{t_{pk}} = \frac{5.36 \times 200}{12} = \mathbf{89.33}$ cumec, which occurs at $\frac{t}{t_{pk}} = 1$

or $t = t_{pk} = \mathbf{12 \text{ hr}}$

(ii) At $\frac{t}{t_{pk}} = 0.5$ or $t = 0.5 \times 12 = \mathbf{6 \text{ hr}}$, $\frac{Q}{Q_p} = 0.4$ or $Q = 0.4 \times 89.33 = \mathbf{35.732}$ cumec

(iii) At $\frac{t}{t_{pk}} = 2$ or $t = 2 \times 12 = \mathbf{24 \text{ hr}}$, $\frac{Q}{Q_p} = 0.32$ or $Q = 0.32 \times 89.33 = \mathbf{28.6}$ cumec

(iv) At $\frac{t}{t_{pk}} = 3$ or $t = 3 \times 12 = \mathbf{36 \text{ hr}}$, $\frac{Q}{Q_p} = 0.075$, or $Q = 0.075 \times 89.33 = \mathbf{6.7}$ cumec

Time base $T = 5 t_{pk} = 5 \times 12 = 60 \text{ hr}$; $W_{75} = W_{50}/1.75$

With this, a 4-hr UH can be sketched.

5.11 APPLICATION OF UNIT HYDROGRAPH

The application of unit hydrograph consists of two aspects:

(i) From a unit hydrograph of a known duration to obtain a unit hydrograph of the desired duration, either by the S-curve method or by the principle of superposition.

(ii) From the unit hydrograph so derived, to obtain the flood hydrograph corresponding to a single storm or multiple storms. For design purposes, a design storm is assumed, which with the help of unit hydrograph, gives a design flood hydrograph.

While the first aspect is already given, the second aspect is illustrated in the following example.

Example 5.10 The 3-hr unit hydrograph ordinates for a basin are given below. There was a storm, which commenced on July 15 at 16.00 hr and continued up to 22.00 hr, which was followed by another storm on July 16 at 4.00 hr which lasted up to 7.00 hr. It was noted from the mass curves of self-recording raingauge that the amount of rainfall on July 15 was 5.75 cm from 16.00 to 19.00 hr and 3.75 cm from 19.00 to 22.00 hr, and on July 16, 4.45 cm from 4.00 to 7.00 hr. Assuming an average loss of 0.25 cm/hr and 0.15 cm/hr for the two storms, respectively,

and a constant base flow of 10 cumec, determine the stream flow hydrograph and state the time of occurrence of peak flood.

| | | | | | | | | | | |
|--------------|---|-----|-----|-----|------|-----|-----|-----|-----|----|
| Time (hr): | 0 | 3 | 6 | 9 | 12 | 15 | 18 | 21 | 24 | 27 |
| UGO (cumec): | 0 | 1.5 | 4.5 | 8.6 | 12.0 | 9.4 | 4.6 | 2.3 | 0.8 | 0 |

Solution Since the duration of the UG is 3 hr, the 6-hr storm (16.00 to 22.00 hr) can be considered as 2-unit storm producing a net rain of $5.75 - 0.25 \times 3 = 5$ cm in the first 3-hr period and a net rain of $3.75 - 0.25 \times 3 = 3$ cm in the next 3-hr period. The unit hydrograph ordinates are multiplied by the net rain of each period lagged by 3 hr. Similarly, another unit storm lagged by 12 hr (4.00 to 7.00 hr next day) produces a net rain of $4.45 - 0.15 \times 3 = 4$ cm which is multiplied by the UGO and written in col (5) (lagged by 12 hr from the beginning), Table 5.9. The rainfall excesses due to the three storms are added up to get the total direct surface discharge ordinates. To this, the base flow ordinates (BFO = 10 cumec, constant) are added to get the total discharge ordinates (stream flow).

The flood hydrograph due to the 3 unit storms on the basin is obtained by plotting col (8) vs. col. (1) (Fig. 5.33). This example illustrates the utility of the unit hydrograph in deriving flood hydrographs due to a single storm or multiple storms occurring on the basin.

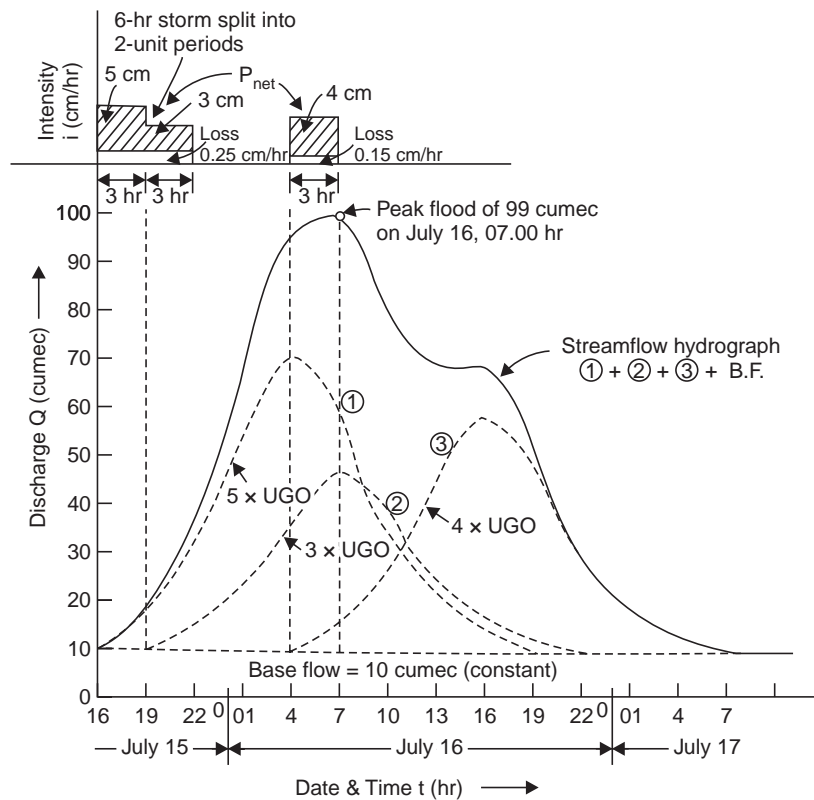

Fig. 5.33 Application of UG to obtain stream flow hydrograph (Example 5.10)

Table 5.9 Derivation of the flood hydrograph due to multiple storms (Example 5.10)

| Time (hr) | DRO due to rainfall excess | | | | Total | | TRO (6) + (7) | Remarks |
|--------------|----------------------------|------------------|-------------------|------------------------|-------------------|-----|------------------|---|
| | I UGO × 5 cm | II UGO × 3 cm | III UGO × 4 cm | DRO (3) + (4) + (5) | BFO (constant) | DRO | | |
| 1 | 2 | 3 | 4 | 5 | 6 | 7 | 8 | |
| 0 | 0 | 0 | — | — | 0 | 10 | 10.0 | — July 15, 16.00 hr |
| 3 | 1.5 | 7.5 | 0 | — | 7.5 | 10 | 17.5 | commencement of flood |
| 6 | 4.5 | 22.5 | 4.5 | — | 27.0 | 10 | 37.0 | |
| 9 | 8.6 | 43.0 | 13.5 | — | 56.5 | 10 | 66.5 | |
| 12 | 12.0 | 60.0 | 25.8 | 0 | 85.8 | 10 | 95.8 | |
| 15 | 9.4 | 47.0 | 36.0 | 6 | 89.0 | 10 | 99.0 | — Peak flood on July 16, |
| 18 | 4.6 | 23.0 | 28.2 | 18 | 69.2 | 10 | 79.2 | 07.00 hr |
| 21 | 2.3 | 11.5 | 13.8 | 34.4 | 59.7 | 10 | 69.7 | |
| 24 | 0.8 | 4.0 | 6.9 | 48 | 58.9 | 10 | 68.9 | |
| 27 | 0 | 0 | 2.4 | 37.6 | 40.0 | 10 | 50.0 | |
| 30 | | | 0 | 18.4 | 18.4 | 10 | 28.4 | |
| 33 | | | | 9.2 | 9.2 | 10 | 19.2 | |
| 36 | | | | 3.2 | 3.2 | 10 | 13.2 | |
| 39 | | | | 0 | 0 | 10 | 10.0 | — Flood subsides on July 17 07.00 hr |

*All columns are in cumec units except col (1).

Example 5.11 The design storm of a water shed has the depths of rainfall of 4.9 and 3.9 cm for the consecutive 1-hr periods. The 1-hr UG can be approximated by a triangle of base 6 hr with a peak of 50 cumec occurring after 2 hr from the beginning. Compute the flood hydrograph assuming an average loss rate of 9 mm/hr and constant base flow of 10 cumec. What is the area of water shed and its coefficient of runoff?

Solution (i) The flood hydrograph due to the two consecutive hourly storms is computed in Table 5.10, Fig. P5.34.

(ii) Area of water shed—To produce 1-cm net rain over the entire water shed ($A \text{ km}^2$).

Volume of water over basin = Area of UG (triangle)

$$(A \times 10^6) \frac{1}{100} = \frac{1}{2} (6 \times 60 \times 60) 50$$

from which, $A = 54 \text{ km}^2$

(iii) Coefficient of runoff $C = \frac{R}{P} = \frac{(4.9 - 0.9) + (3.9 - 0.9)}{4.9 + 3.9} = 0.795$

Table 5.10 Computation of design flood hydrograph (Example 5.11)

| Time (hr) | UGO* (cumec) | DRO due to rain- fall excess (cumec) | | Total (cumec) | BF (cumec) | TRO (cumec) | Remarks |
|--------------|-----------------|---|---------------------|------------------|---------------|--------------------------|---------|
| | | 4.9 - 0.9 = 4 cm | 3.9 - 0.9 = 3 cm | | | | |
| 1 | 0 | 0 | — | 0 | 10 | 10 | |
| 2 | 25 | 100 | 0 | 100 | 10 | 110 | |
| 3 | 50 | 200 | 75 | 275 | 10 | 285 | |
| 4 | 37.5 | 150 | 150 | 300 | 10 | 310 ← Peak flood† | |
| 5 | 25 | 100 | 112.5 | 212.5 | 10 | 222.5 | |
| 6 | 12.5 | 50 | 75 | 125 | 10 | 135 | |
| 7 | 0 | 0 | 37.5 | 37.5 | 10 | 47.5 | |
| 8 | — | — | 0 | 0 | 10 | 10 | |

*Ordinates by proportion in the triangular UG. †—Peak flood of 310 cumec, after 4 hr from the commencement of the storm.

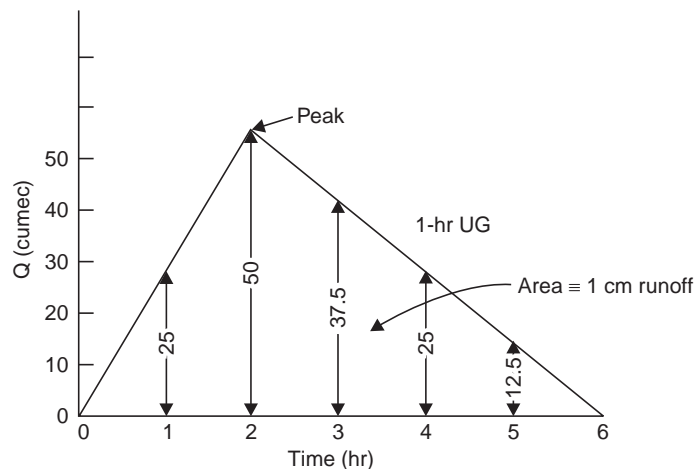

Fig. 5.34 (Example 5.11)

Table 5.11 Computation of stream flow from distribution percentages. (Example 5.12)

| Time (hr) | Distribution percentages | Rainfall excess (cm) | DRO due to rainfall excess (cm) | | | | Total DRO (cm) | BF (cumec) | Stream flow (cumec) | Remarks |
|--------------|--------------------------|----------------------|---------------------------------|-------------|-------------|--------------|----------------|------------|---------------------|--|
| | | | 2 | 7 | 4 | 4 | | | | |
| 1 | 5 | 3.2 - 1.2 = 2 | 0.10 | — | — | 0.10 | 12.5* | 10 | 22.5 ← | June 4, 1982 04.00 hr |
| 2 | 20 | 8.2 - 1.2 = 7 | 0.40 | 0.35 | — | 0.75 | 93.75 | 10 | 103.75 | Commencement of flood |
| 3 | 40 | 5.3 - 1.2 = 4 | 0.80 | 1.40 | 0.20 | 2.40 | 300 | 10 | 310 | |
| 4 | 20 | | 0.40 | 2.80 | 0.80 | 4.00 | 500 | 10 | 510 ← | Peak flood at 07.00 hr on June 4, 1982 |
| 5 | 10 | | 0.20 | 1.40 | 1.60 | 3.20 | 400 | 10 | 410 | |
| 6 | 5 | | 0.10 | 0.70 | 0.80 | 1.60 | 200 | 10 | 210 | |
| 7 | — | | — | 0.35 | 0.40 | 0.75 | 93.75 | 10 | 103.75 | |
| 8 | — | | — | — | 0.20 | 0.20 | 25 | 10 | 35 | |
| Total | 100 | 13 | 2.00 | 7.00 | 4.00 | 13.00 | 1625 | | | |

* $\frac{0.10}{100} \frac{(45 \times 10^6)}{1 \times 60 \times 60} = 12.5 \text{ cumec.}$

Example 5.12 Storm rainfalls of 3.2, 8.2 and 5.2 cm occur during three successive hours over an area of 45 km². The storm loss rate is 1.2 cm/hr. The distribution percentages of successive hours are 5, 20, 40, 20, 10 and 5. Determine the streamflows for successive hours assuming a constant base flow of 10 cumec. State the peak flow and when it is expected; the precipitation started at 04.00 hr, on June 4, 1982.

Solution The computation of stream flow hydrograph from the distribution percentages due to net rainfall in three successive hours (i.e., from a complex storm) over an area of 45 km² is made in Table 5.11.

Example 5.13 The successive three-hourly ordinates of a 6-hr UG for a particular basin are 0, 15, 36, 30, 17.5, 8.5, 3, 0 cumec, respectively. The flood peak observed due to a 6-hr storm was 150 cumec. Assuming a constant base flow of 6 cumec and an average storm loss of 6 mm/hr, determine the depth of storm rainfall and the streamflow at successive 3 hr interval.

Solution

$$\begin{aligned} \text{DRO peak} &= \text{Flood peak} - \text{BF} \\ &= 150 - 6 = 144 \text{ cumec} \end{aligned}$$

$$P_{\text{net}} = \frac{\text{DRO}_{\text{peak}}}{\text{UG}_{\text{peak}}} = \frac{144}{36} = 4 \text{ cm}$$

Depth of storm rainfall,

$$P = P_{\text{net}} + \text{losses} = 4 + 0.6 \times 6 = 7.6 \text{ cm.}$$

$$\text{DRO} = \text{UGO} \times P_{\text{net}}; \quad \text{DRO} + \text{BF} = \text{TRO}$$

Hence, multiplying the given UGO by 4 cm and adding 6 cumec, the stream flow ordinates at successive 3-hr intervals are: 6, 66, 150, 126, 76, 40, 18, 6 cumec, respectively.

QUIZ V

I Match the items in 'A' with items in 'B'

A

- (i) Ground water depletion
- (ii) Unit hydrograph
- (iii) TRO
- (iv) UGO
- (v) Unit duration
- (vi) Change of unit duration
- (vii) Distribution percentages
- (viii) Design storm
- (ix) Ungauged stream

B

- (a) Unit storm
- (b) Flood hydrograph
- (c) Bernard
- (d) Synthetic unit hydrograph
- (e) S-curve hydrograph
- (f) $(\text{TRO} - \text{BFO}) \div P_{\text{net}}$
- (g) $\text{UGO} \times P_{\text{net}} + \text{BFO}$
- (h) 1 cm of runoff
- (i) Base flow recession curve

II Say 'true' or 'false', if false, give the correct statement.

- (i) Unit hydrographs should be used for basins, larger than 5000 km².
- (ii) Larger unit periods are required for larger basins.
- (iii) If the peak of the unit hydrograph is 25 cumec, then the peak of the hydrograph producing 8 cm of runoff is 215 cumec, assuming a constant base flow of 15 cumec.

- (iv) The base flow of surface streams is the effluent seepage from the drainage basin.
 - (v) The ground water depletion curves are not of the same pattern for all the storms in a drainage basin.
 - (vi) When dealing with small streams, a hydrograph of instantaneous flow should be constructed, wherever possible.
 - (vii) The best unit duration is about one-fourth of the basin lag.
 - (viii) The period of surface runoff is different for unit storms of different intensity.
 - (ix) If the period of surface runoff is divided into equal time intervals, the percentage of surface runoff that occurs during each of these intervals will be different for unit storms of different intensities.
 - (x) The hydrograph of runoff for a basin reflects the combined physical characteristics of the basin including infiltration, surface detention and storage.
 - (xi) The inflection point signifies gradual withdrawal of catchment storage.
 - (xii) The unit storm is of such duration that the period of surface runoff is much less for any other storm of shorter duration.
 - (xiii) The shape of the hydrograph of runoff will be affected by:
 - (i) the duration of the storm
 - (ii) areal distribution of the storm
 - (iii) the intensity of the storm
- (false: *i, v, viii, ix, xii*)

III Fill up the blanks correctly:

- (i) The 3-hour unit hydrograph gives a net rain of cm on the entire basin, for the rainfall duration of hours.
- (ii) To convert a unit hydrograph of a known duration to some other required duration ... technique is adopted.
- (iii) The three basic propositions of the unit hydrograph theory are:
 - (a)
 - (b)
 - (c)
- (iv) hydrograph is constructed to serve as a unit hydrograph for a basin whose stream is not gauged.
- (v) The ground water contribution to the discharge in a stream is called
- (vi) If the seepage from the stream builds up a ground water mound, such a stream is called

IV Choose the correct statement/s in the following:

- 1 A 4-hr unit (1 cm) hydrograph means
 - (i) the duration of rainfall is 4 hours.
 - (ii) the intensity of rainfall over the entire catchment is 2.5 mm/hr constant.
 - (iii) 1 cm depth of rainfall over the entire catchment.
 - (iv) 1 cm depth of rainfall excess over the entire catchment.
 - (v) a hydrograph resulting from the instantaneous application of 1 cm rainfall excess over the basin.

- (vi) that the stream flow is for 4 hours.
- (vii) that the volume of direct surface runoff in the stream is $10^4 A \text{ m}^3$ (A = area of basin in km^2).
- (viii) all the above.
- 2** Given a 4-hr unit (1 cm) hydrograph (UG), for any storm of 4-hr duration producing x cm of rainfall excess
- (i) the peak of direct runoff hydrograph (DRH) is x times the peak of UG.
- (ii) the duration of direct surface runoff (DSR) is the same as that of UG.
- (iii) if the duration of DSR in DRH and UG are divided into 8 unit periods, the percentage of DSR in the corresponding unit periods in both, is the same.
- (iv) the ratio of the corresponding ordinates in each unit period of DRH and UG is x .
- (v) all the above relations.
- 3** A S-curve hydrograph derived from a 4-hr UG (time base $T = 24$ hr) for a 640 km^2 basin
- (i) is the result of six 4-hr unit storms occurring in succession over the basin.
- (ii) produces a constant outflow 445 cumec after 24 hours.
- (iii) the constant outflow of 445 cumec is produced after 6 hours.
- (iv) the shape of the curve in the first 24 hours is in the form of letter S.
- (v) all the above items.
- 4** A synthetic unit hydrograph is developed
- (i) for a basin whose stream is gauged.
- (ii) for a basin over which no raingauge and stream gauge stations are established.
- (iii) by measuring the mainstream lengths like L and L_{ca} , and area of the basin.
- (iv) by computing the basin slope.
- (v) by taking certain constants from another basin, which is hydrometeorologically homogeneous.
- (vi) for a basin having a raingauge network but with no stream gauging station
- (viii) from items (iii) (v) and (vi) above.
- 5** The shape of the hydrograph is effected by
- (i) non-uniform areal distribution of rainfall.
- (ii) varying rainfall intensity.
- (iii) shape of the basin.
- (iv) direction of storm movement.
- (v) all the above factors.
- 6** Given a 3-hr UG, the stream flow hydrograph due to a 6-hr storm producing 7 cm of rainfall excess, can be derived by
- (i) multiplying the 3-hr UGO by 7 and adding base flow, if any.
- (ii) deriving a 6-hr UG, from the 3-hr UG, multiplying the 6-hr UGO by 7 and then adding base flow, if any.
- (iii) multiplying the 6-hr UGO (derived from the 3-hr UGO) by 7 and deducting the base flow, if any.
- (iv) if the storm had uniformly produced 3 cm in the first 3 hr and 4 cm in the next 3 hr, multiplying the 3-hr UGO by 3 and then by 4, adding the DRO's lagged by 3 hr, and then adding base flow, if any.
- (1-i, ii, iv, vii; 2-v; 3-except iii, 4-vi, vii; 5-v; 6-except iii)

QUESTIONS

- 1 (a) Define hydrograph. Draw a single-peaked hydrograph and indicate its various components.
(b) State the significance of the inflection point on the recession side of the hydrograph.
- 2 It is ascertained that various factors affect the shape of the flood hydrograph. What are those factors? Grouping the above under rainfall factors, loss factors and physiographic factors, indicate how all these affect the shape of the hydrograph.
- 3 Describe with the help of a neat sketch any three methods of separation of base flow from the hydrograph of runoff (*i.e.*, stream flow hydrograph) indicating the situations under which you advocate them.
- 4 (a) What are the three basic propositions of the unit hydrograph theory ?
(b) The following are the ordinates of the hydrograph of flow from a catchment area of 780 km² due to a 6-hour rainfall. Derive the ordinates for 6-hour unit hydrograph for the basin and state its peak.

| <i>Date</i> | <i>Time from beginning of rainfall (hr)</i> | <i>Discharge (cumec)</i> | <i>Remarks</i> |
|-------------|---|------------------------------|----------------|
| 1-3-1980 | 6 | 40 | |
| | 12 | 64 | |
| | 18 | 215 | |
| 2-3-1980 | 0 | 360 | |
| | 6 | 405 | ← Peak |
| | 12 | 350 | |
| | 18 | 270 | |
| 3-3-1980 | 0 | 205 | |
| | 6 | 145 | |
| | 12 | 100 | |
| | 18 | 70 | |
| 4-3-1980 | 0 | 50 | |
| | 6 | 42 | |

- 5 (a) What do you understand by 'a 6-hour unit hydrograph' ?
(b) A steady 6-hour rainfall with an intensity of 4 cm/hr produces a peak discharge of 560 cumec. The average storm loss can be assumed as 1 cm/hr and base flow 20 cumec. What is the peak discharge of the unit hydrograph and its duration? On the same basin, determine the peak discharge from a 6-hour rainfall at an intensity of 3.5 cm/hr assuming an average loss rate of 1.5 cm/hr and base flow of 15 cumec. (30 cumec, 6-hr; 375 cumec)
- 6 (a) Explain the use of the unit hydrograph in the construction of the flood hydrograph resulting from two or more periods of rainfall.

(b) The following are the ordinates of 3-hour unit hydrograph:

| <i>Time</i> (hr) | <i>3-hr UGO</i> (cumec) | <i>Time</i> (hr) | <i>3-hr UGO</i> (cumec) |
|---------------------|----------------------------|---------------------|----------------------------|
| 0 | 0 | 15 | 9.4 |
| 3 | 1.5 | 18 | 4.6 |
| 6 | 4.5 | 21 | 2.3 |
| 9 | 8.6 | 24 | 0.8 |
| 12 | 12.0 | 27 | 0 |

Derive the flood hydrograph due to a 6-hour storm producing a total rainfall 4.5 cm in the first three hours and 3.5 cm in the next three hours. Assume an average infiltration loss of 0.5 cm/hr and a constant base flow of 3 cumec. State the peak flood in the stream and after how many hours it will occur since the commencement of storm. Also state the basin lag (time lag).

7 (a) What is an instantaneous unity hydrograph?

(b) Given below are the streamflows from a catchment area of 20 km² due to a storm of 1-hour duration. Find the surface runoff hydrograph ordinates from an effective rainfall (net rain) of 6 cm and of duration 1 hour. Assume a constant base flow of 15 cumec.

| | | | | | | | | | | | |
|-----------------------------|----|----|----|----|----|----|----|----|----|----|----|
| <i>Time (hr):</i> | 0 | 1 | 2 | 3 | 4 | 5 | 6 | 7 | 8 | 9 | 10 |
| <i>Stream flow (cumec):</i> | 15 | 25 | 50 | 55 | 48 | 35 | 30 | 27 | 24 | 20 | 15 |

8 (a) What are the limitations of unit hydrograph?

(b) The stream flows due to three successive storms of 3.5, 4.5 and 2.5 cm of 6 hours duration each on a basin are given below. The area of the basin is 45.4 km². Assuming a constant base flow of 10 cumec, and an average storm loss of 0.25 cm/hr, derive the ordinates of a 6-hour unit hydrograph for the basin.

| | | | | | | | |
|-----------------------------|----|----|----|----|----|----|----|
| <i>Time (hr):</i> | 0 | 3 | 6 | 9 | 12 | 15 | 18 |
| <i>Stream flow (cumec):</i> | 10 | 14 | 18 | 32 | 46 | 54 | 58 |

| | | | | | | | |
|-----------------------------|----|----|----|----|----|----|----|
| <i>Time (hr):</i> | 21 | 24 | 27 | 30 | 33 | 36 | 39 |
| <i>Stream flow (cumec):</i> | 49 | 36 | 25 | 17 | 12 | 11 | 10 |

(0, 2, 4, 8, 12, 9, 4, 2, 1, 0)

9 The ordinates of a 3-hr UG are given in problem 6 (b). Derive the flood hydrograph due to a 3-hr storm, producing a rainfall excess (net rain) of 4 cm. The base flow is estimated to be 3 cumec and may be assumed constant. (3, 9, 21, 37.4, 51, 40.6, 21.4, 12.2, 6.2, 3 cumec)

10 (a) Define 'a S-curve hydrograph' giving a neat sketch, and state its use.

(b) The ordinates of a 12-hour unit hydrograph are given below. Compute a 6-hour unit hydrograph ordinates and plot: (i) the S-curve and (ii) the 6-hour UG

| | | | | | | | | | | | | | |
|---------------------------|---|---|----|----|----|----|----|----|----|----|----|----|----|
| <i>Time (hr):</i> | 0 | 6 | 12 | 18 | 24 | 30 | 36 | 42 | 48 | 54 | 60 | 66 | 72 |
| <i>12-hr UGO (cumec):</i> | 0 | 1 | 4 | 8 | 16 | 19 | 15 | 12 | 8 | 5 | 3 | 2 | 1 |

11 The ordinates of a 4-hour unit hydrograph are given below. Derive the ordinates of a 8-hour unit hydrograph by the S-curve method or otherwise.

| <i>Time</i> (hr) | <i>4-hr UGO</i> (cumec) | <i>Time</i> (hr) | <i>4-hr UGO</i> (cumec) |
|---------------------|----------------------------|---------------------|----------------------------|
| 0 | 0 | 24 | 103 |
| 4 | 24 | 28 | 64 |
| 8 | 82 | 32 | 36 |
| 12 | 159 | 36 | 17 |
| 16 | 184 | 40 | 6 |
| 20 | 151 | 44 | 0 |

- 12 The ordinates of a 6-hour UG are given below. Derive the ordinates of a 12-hour UG without resorting to the *S*-curve technique.

| | | | | | | | | | | | |
|--------------------------|---|---|----|----|----|----|----|----|----|----|----|
| <i>Time (hr):</i> | 0 | 6 | 12 | 18 | 24 | 30 | 36 | 42 | 48 | 54 | 60 |
| <i>6-hr UGO (cumec):</i> | 0 | 5 | 13 | 30 | 35 | 32 | 20 | 14 | 8 | 4 | 0 |

- 13 The ordinates of a 3-hour UG are given in problem 6 (b). Derive the ordinates of a 6-hour UG and state its peak.

- 14 (a) Explain ‘synthetic unit hydrograph’.

- (b) A drainage basin has an area of 1700 km².

Construct a 6-hour unit hydrograph, the data is given below:

Length of the longest water course = 82 km

Length along the main water course from the gauging station to a point opposite the centroid of the basin = 48 km

From another catchment, which is meteorologically and hydrologically homogeneous, the constants obtained:

$$C_t = 1.2, C_p = 5$$

(14.5 hr, 587 cumec, 4.9 days; 18, 10 hr)

- 15 The following are the ordinates of a 6-hr UG for a basin:

| | | | | | | | | | |
|--------------------------|---|----|----|----|-----|-----|-----|-----|-----|
| <i>Time (hr):</i> | 0 | 6 | 12 | 18 | 24 | 30 | 36 | 42 | 48 |
| <i>6-hr UGO (cumec):</i> | 0 | 20 | 56 | 98 | 127 | 147 | 156 | 154 | 140 |

| | | | | | | | | |
|--------------------------|-----|-----|----|----|----|----|----|----|
| <i>Time (hr):</i> | 54 | 60 | 66 | 72 | 78 | 84 | 90 | 96 |
| <i>6-hr UGO (cumec):</i> | 122 | 107 | 93 | 78 | 65 | 52 | 41 | 30 |

| | | | | | | | | |
|--------------------------|------|------|-----|-----|-----|-----|-----|-----|
| <i>Time (hr):</i> | 102 | 108 | 114 | 120 | 126 | 132 | 138 | 144 |
| <i>6-hr UGO (cumec):</i> | 20.7 | 14.5 | 10 | 6.7 | 4.5 | 2.2 | 1.1 | 0 |

Details of the gauged basin:

$$A = 3230 \text{ km}^2, L = 150 \text{ km}, L_{ca} = 76 \text{ km}$$

Another basin which is meteorologically and hydrologically similar has the following details.

$$A = 2430 \text{ km}^2, L = 140 \text{ km}, L_{ca} = 75 \text{ km}$$

and the basin is not gauged. Derive a 6-hour synthetic-unit hydrograph for the ungauged basin.

- 16** Snyder's method has been applied for the construction of synthetic-unit hydrograph for a sub-catchment of Ramganga basin at Kalagarh in U.P., north India and the following data apply:

(a) For the whole Ramganga catchment:

| | |
|--|------------------------|
| Area of catchment | = 3100 km ² |
| Peak of 24-hour design unit hydrograph | = 782 cumec |
| Time to peak (from the beginning of rising limb) | = 33 hours |
| Time base | = 4 days |

$L = 157.5 \text{ km}$
 $L_{ca} = 77.25 \text{ km}$ } measured from the index map

(b) For the sub-catchment of Ramaganga:

| | |
|-------------------|-------------------------|
| Area of catchment | = 323.5 km ² |
| L | = 32 km |
| L_{ca} | = 24.96 km |

Construct a 8-hour synthetic unit hydrograph for the sub-catchment of Ramganga.

$$(C_t = 0.93, C_p = 5.29, t_{pr} = 8.59 \text{ hr})$$

$$Q_p = 199.3 \text{ cumec}, T = 97.7 \text{ hr or } 62.95 \text{ hr}$$

$$W_{50} = 9.43 \text{ hr}, W_{75} = 5.4 \text{ hr}$$

- 17** A drainage basin has an area of 3800 km². Determine: (i) lag period, (ii) peak discharge, and (iii) base period, of a 9-hour unit hydrograph from the following data:

$$L = 320 \text{ km}, L_{ca} = 200 \text{ km}, C_t = 0.9, C_p = 4.0$$

- 18** Storm rainfalls of 3, 7.5 and 5.5 cm occur during the three successive hours over a 30 km² area. The loss rate can be assumed as 1.5 cm/hr on an average. The distribution percentages for successive hours are 5, 20, 40, 20, 10 and 5. Determine the stream flows for successive hours assuming a constant base flow of 20 cumec, state its peak and when it is expected.

$$(26, 25, 70, 187, 311, 266, 143, 78, 37 \text{ cumec})$$

- 19** The design storm over a water shed has depths of rainfall of 4, 6, 3.6 and 5.6 cm in successive 1-hr periods. The 1-hr UG can be approximated by a triangle of base of 9 hr with a peak of 50 cumec occurring after 2 hr from the beginning. Compute the flood hydrograph assuming an average loss rate of 6 mm/hr and constant flow of 5 cumec. What is the area of water shed and its coefficient of runoff?

- 20** Distinguish between:

- (i) a hydrograph and a hyetograph
- (ii) lag time and recession time
- (iii) a concentration curve and a recession curve

- 21** Write short notes on:

- (i) Meteorological homogeneity
- (ii) Ground water depletion curve
- (iii) Bernard's distribution graph

- 22** During a draught spell in a basin, the stream flow was 90 cumec after 10 days without rain, and 40 cumec after 30 days without rain. Derive the equation of the ground water depletion (recession) curve. What is the streamflow after 100 days without rain? What is the change in ground water storage from 10 to 100 days without rain?

- 23 A 3-hr UG for a basin can be approximated by a triangle of base 24 hr and peak (apex) of 50 cumec occuring after 8 hr from the beginning. A 4-hr storm occurred over the basin with an intensity of 2.6 cm/hr. Assuming an average loss rate of 6 mm/hr and a constant base flow of 6 cumec, determine the streamflow at 4, 8 and 16 hr, respectively from the beginning. What is the area of the drainage basin? Also determine the coefficient of runoff of the basin.

Hint $C = \frac{i - W_i}{i}$ (156, 306, 156 cumec; 216 km²; 0.8)

- 24 The flood at the Pampanga river at San Anton, Philippines during October 4-10, 1964 is given in Table 1. The watershed area is 2851 km². The hourly rainfall data measured by the recording raingauges at Cabanatuan is given in Table 2.

- (i) Plot the distribution of hourly rainfall as a histogram
- (ii) Compute the ϕ -index
- (iii) Verify whether the computed value is correct by using the histogram

Table 1 Daily runoff data of Pampanga river

| <i>Date</i> | <i>Stream flow (cumec)</i> | <i>Base flow (cumec)</i> |
|-----------------|--------------------------------|------------------------------|
| October 1964, 4 | 325 | 325 |
| 5 | 364 | 315 |
| 6 | 502 | 290 |
| 7 | 452 | 277 |
| 8 | 470 | 263 |
| 9 | 465 | 252 |
| 10 | 240 | 240 |

Table 2 Hourly rainfall data at Cabanatuan

| <i>Date</i> | <i>Hour</i> | <i>Rainfall (mm)</i> | <i>Date</i> | <i>Hour</i> | <i>Rainfall (mm)</i> |
|--------------------|-------------|--------------------------|-------------|-------------|--------------------------|
| October 5, 1964 | 9 | 14.3 | October 6 | 17 | 17.2 |
| | 10 | 8.0 | | 18 | 2.0 |
| | 11 | 7.2 | | 19 | 0.9 |
| | 12 N | 3.8 | | 20 | 1.5 |
| | 13 | 2.0 | | | |
| October 6, | 14 | 1.3 | | | |
| | 4 | 1.0 | | | |
| | 5 | 0 | | | |
| | 6 | 0.8 year | | | |
| | 7 | 0 | | | |
| | 8 | 13.9 | | | |

(Ans. 73.9 – 48.0 = 25.9 mm, 6.94 mm/hr)

25 Storm rainfalls of 4.5 and 8 cm occurred over an area of 3750 km² on July 10 and 11, respectively in a certain year. The loss rate can be assumed as 2.5 and 2 cm for the two days, respectively. The distribution percentage for the successive days are 20, 40, 15, 12, 8, 4 and 1. Determine the streamflows for the successive days in cumec, assuming a base flow of 40 cumec for the first 2 days, 80 cumec for the next 2 days, 60 cumec for further 2 days and 40 cumec for the subsequent days. State the peak flood and the date of its occurrence.

26 The flood water level (river stage H) since commencement of a 4-hr storm on a 2200 km² basin is given below. Derive and sketch a 4-hr UH (unit is 1 cm), assuming a constant base flow of 9 cumec.

| | | | | | | | | | | | | |
|--------------|-----|-----|-----|-----|-----|-----|-----|-----|-----|-----|-----|-----|
| Time (hr): | 0 | 2 | 4 | 6 | 8 | 10 | 12 | 14 | 16 | 18 | 20 | 22 |
| Stage, H(m): | 0.5 | 3.0 | 4.5 | 4.6 | 4.3 | 3.3 | 2.8 | 2.2 | 1.9 | 1.2 | 1.0 | 0.5 |

Stage-discharge relation : $Q = 100 (H - 0.2)^2$, Q in cumec.

(Ans. $P_{\text{net}} = 2.86$ cm; UHO: 0, 271, 644, 674, 585, 333, 233, 166, 98, 32, 19, 0, cumec)

27 Using the lag time of the SUH obtained in problem 16, for the sub-catchment of Ramganga ($A = 323.5$ km²) develop a 8 hr-UG by SCS method, given ($pk = \text{peak}$) :

| | | | | | | |
|----------------------|-----|---|------|-------|-------|-------|
| $\frac{t}{t_{pk}}$: | 0.5 | 1 | 2 | 3 | 4 | 5 |
| $\frac{Q}{Q_p}$: | 0.4 | 1 | 0.32 | 0.075 | 0.018 | 0.004 |

28 In a stream the base flow is observed to be 30 cumec on July 14, and 23 cumec on July 23. Estimate the base flow on August 10, and ground water storage on July 14 and August 10.

(Ans. Q (28 days) = 13.5 cumec; 88, 40 Mm³)

29 An agricultural watershed was urbanised over a period of 30 years. The rainfall loss was 9 mm/hr before urbanisation, which dropped to 4 mm/hr after urbanisation. The 1-hr UG (unit 1 cm) of this watershed can be assumed as a triangle of base 12 hr and height 160 cumec after 4 hr before urbanisation and of base 8 hr and height 240 cumec after 3 hr, after urbanisation.

(a) Determine the area of the watershed.

(b) Draw the flood hydrograph after urbanisation for a storm of intensity 19 mm/hr for 1 hr and 29 mm/hr in the next hour. Assume a uniform loss rate and a constant base flow of 10 cumec.

(c) Compute the coefficient of runoff before and after urbanisation.

(Ans. $A = 346$ km², $C = 0.67, 0.83$)

Note The triangular areas of both the UG's are same.

Chapter 6

STREAM GAUGING

6.1 METHODS OF MEASURING STREAM FLOW

The most satisfactory determination of the runoff from a catchment is by measuring the discharge of the stream draining it, which is termed as *stream gauging*. A *gauging station* is the place or section on a stream where discharge measurements are made. Some of the usual methods of stream gauging are given below:

(a) Venturiflumes or standing wave flumes (critical depth meter) for small channels.

(b) Weirs or anicuts: $Q = CLH^{3/2}$... (6.1)

where Q = stream discharge, C = coefficient of weir, L = length of weir (or anicut), H = head (depth of flow) over the weircrest

(c) Slope-area method: $Q = AV$... (6.2)

$$V = C\sqrt{RS} \quad \text{---Chezy} \quad \dots(6.2 a)$$

$$V = \frac{1}{n} R^{2/3} S^{1/2} \quad \text{---Manning} \quad \dots(6.2 b)$$

$$\text{Chezy's } C = \frac{1}{n} R^{1/6}, \quad R = \frac{A}{P} \quad \dots(6.2 c)$$

where C = Chezy's constant

N = Manning's coefficient of roughness

R = hydraulic mean radius

A = cross-sectional area of flow

P = wetted perimeter

S = water surface slope (= bed slope)

The cross-sectional area A is obtained by taking soundings below the water level at intervals of, say, 6 m and plotting the profile of the cross-section and drawing the high flood level or water surface level.

The water surface slope is determined by means of gauges placed at the ends of the reach, say 1 km upstream of the gauging station and 1 km downstream of the gauging station (in a straight reach; if Δh is the difference in water levels in a length L of the reach, then

$S = \frac{\Delta h}{L}$. The slope may also be determined by means of flood marks on either side and their subsequent levelling.

Careful notes on the nature of bed and banks, vegetation etc. should be made and if possible a photograph may be taken. From this, the constants C (Chezy's) and n (Manning's) can be found from the Tables.

The slope-area method is often used to estimate peak floods where no gauging station exists.

(d) Contracted area methods:

The drop in water surface in contracted sections as in bridge openings (see Fig. 6.15), canal falls etc. is measured and the discharge is approximately given by

$$Q = C_d A_1 \sqrt{2g(\Delta h + h_a)} \quad \dots(6.3)$$

where C_d = coefficient of discharge

A_1 = area of the most contracted section

Δh = difference in water surface between the upstream and down stream ends (of the pier)

h_a = head due to the velocity of approach.

(e) *Sluiceways, spillways and power conduits.* The flow through any of the outlets in a dam or the sum of the flows through these gives the discharge at any time.

(f) *Salt-concentration method.* The discharge is determined by introducing a chemical, generally common salt, at a known constant rate into flowing water and determining the quantity of chemical in the stream at a section downstream sufficiently distant to ensure thorough mixing of the chemical with water. The discharge.

$$Q = \frac{c - c_2}{c_2 - c_1} q \quad \dots(6.4)$$

where q = quantity of solution injected (cc/sec)

c = amount of salt in dosing solution (gm/cc)

c_1 = concentration of salt originally (before dosing) in the stream (gm/cc)

c_2 = concentration of salt in the sample downstream (gm/cc)

This method is best suited for turbulent waters as the turbulence helps in thorough mixing of the chemical; this is a costly process.

(g) *Area-velocity methods:* $Q = AV$

The area of cross-section of flow may be determined by sounding and plotting the profile. The mean velocity of flow (V) may be determined by making velocity measurements. The velocity distribution in a cross-section and in a vertical in a stream are shown in Fig. 6.1 (a) and (b) and as such the methods of velocity measurements are as follows:

$$\text{Velocity measurements from } \left\{ \begin{array}{l} \text{Floats } \left\{ \begin{array}{l} \text{surface} \\ \text{sub-surface} \end{array} \right\} \text{ measure surface velocity } v_s; \\ \hspace{10em} V \approx 0.85 v_s \\ \text{Velocity rods measure mean velocity, } V \\ \text{Current meter } \left\{ \begin{array}{l} \text{Pigmy} \\ \text{Propeller} \\ \text{Price} \end{array} \right\} \text{ measure mean velocity in a} \\ \hspace{10em} \text{strip of cross-section by} \end{array} \right. \quad \dots(6.5)$$

$$(i) \text{ one point method } V = v_{0.6d} \quad \dots(6.6 a)$$

$$(ii) \text{ two points method } V = \frac{v_{0.2d} + v_{0.8d}}{2}$$

$$(d = \text{mean depth in the strip}) \quad \dots(6.6 b)$$

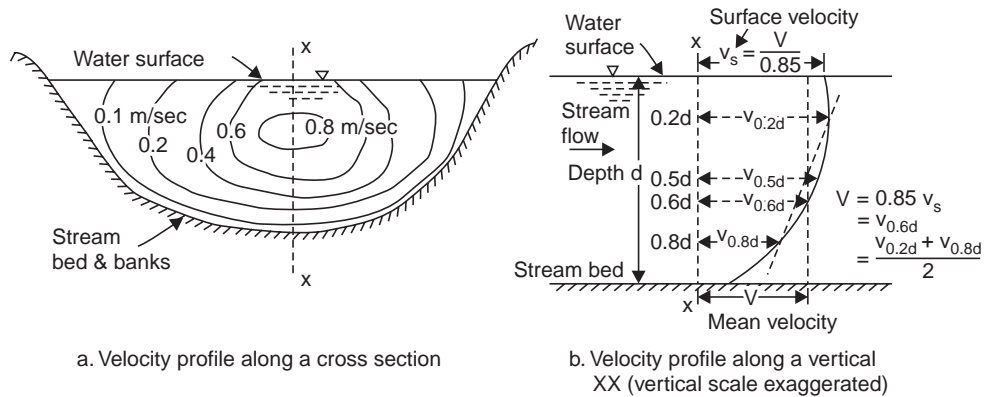

Fig. 6.1 Horizontal and vertical velocity profiles in a stream

Surface floats—consist of wooden discs 7–15 cm diameter (Fig. 6.2 a). The time (t) taken by float to travel a certain distance (L) is measured and the surface velocity v_s and mean velocity V are calculated as $v_s = L/t$ and $V \approx 0.85 v_s$. The reach of the river for float measurements should be straight and uniform and least surface disturbances. The float travel is affected by winds, waves and eddies and sometimes a subsurface or a double float consisting of a metallic hollow cylindrical weighted submerged float attached by means of a thin string to a surface float is used, Fig. 6.2 a.

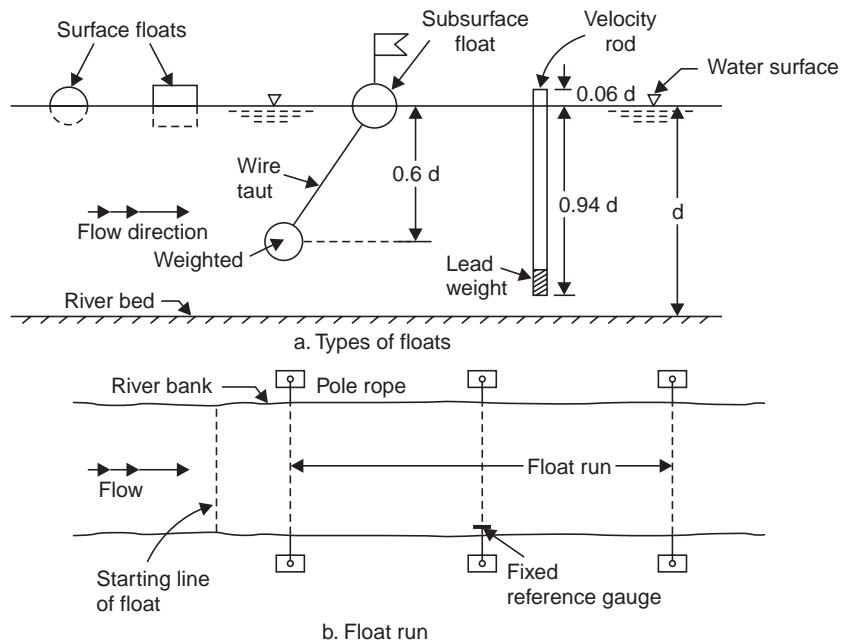

Fig. 6.2 Velocity determination by floats

Velocity rods consist of a wooden rod, square or round in section ($\approx 3\text{--}5$ cm size). It is weighted at the bottom by means of lead or cast iron rings to immerse it to a depth of $0.94d$,

where d is the depth of stream, to give the mean velocity of flow (V). The rods are so weighted that they float nearly vertical with about 3–5 cm projecting above the water surface, so that they can be seen floating. A number of rods are required to suit the varying depths of cross-section.

At the beginning of the gauge run, a surface or rod float is released at the centre of a compartment (Fig. 6.2 *b*). The time taken for the float to reach the end of the gauge run (of the same compartment) is noted. Knowing the length of the gauge run, the velocity of flow is determined.

6.2 CURRENT METER GAUGINGS

The current meter is an instrument, which has a rotating element which when placed in flowing water, the speed of revolutions has a definite relation with the velocity of flow past the element. There are three types of current meters—(i) pigmy current meter, whose cup vane assembly is about 5 cm in diameter and is used for measuring velocities in streams of depth 15 cm or less, (ii) the cup type, which consists of a wheel with conical cups revolving on a vertical axis, and (iii) the screw or propeller type consisting of vanes revolving on a horizontal axis. Price, Ellis, Ottwatt meters are of vertical axis type while Off and Haskel, Amslar, Ott and Aerofoil meters are of horizontal axis type. The Price meter is regarded as a universal meter and is equipped with a pentahead, a device for indicating every fifth revolution. The meter may be used for velocities from 1 to 4.5 m/sec in depths of 1–15 m from a boat, bridge, cable or wading. A counter weight (stream lined) is fixed below the meter to prevent it from swaying, Fig. 6.3.

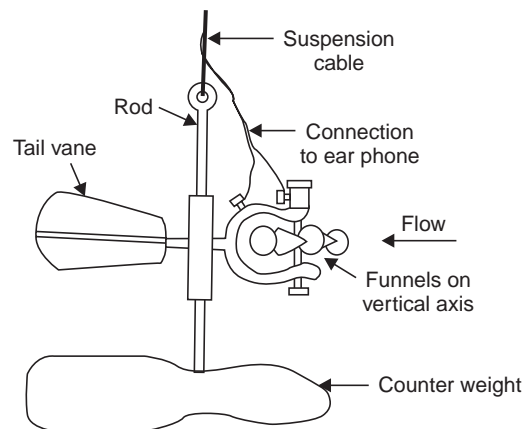

Fig. 6.3 Price current meter

Rating of the Current Meter

The relationship between the revolutions per second (N , rps) of the meter and the velocity of flow past the meter (v , m/sec) has to be first established, or if the rating equation is given by the maker, it has to be verified. This process of calibration of the meter is called *rating of the current meter*. The rating equation is of the form

$$v = aN + b \quad \dots(6.7)$$

where a and b are constants (determined from rating of the current meter).

The rating is done in a masonry tank of approximate dimensions 90 m × 2.4 m × 2.1 m, Fig. 6.4. The meter is towed in still water in the tank either by a pushing trolley (from which the meter is suspended) by men specially trained for the purpose or by an electric motor to move the trolley at a constant speed on a track by the side of the tank, the distances being painted in *m* and *cm* in enamel on the track. A metronome adjusted to give ticks at every 2, 3, 4, 5, 6, 7, 8, 10 sec is kept on the trolley. The men pushing the trolley would have been trained to put paces uniformly to synchronise with the ticking of the metronome. When motorised speeds are adjusted to give different velocities. A *cantilever beam* is fixed to the trolley such that the projecting end is at the centre of the rating tank from which the meter is hung from a *suspension rod*. The meter should be immersed about 1 m below the water surface during rating. The observer sits in the trolley, notes the time and distance traversed by the trolley for a fixed number of revolutions made by the meter (say, 10-100 depending on the speed). This operation is repeated for different pushing velocities of the trolley. A current meter rating curve is drawn as 'pushing velocity vs. rps', which plots a straight line and the constants *a* and *b* are determined as shown in Fig. 6.5.

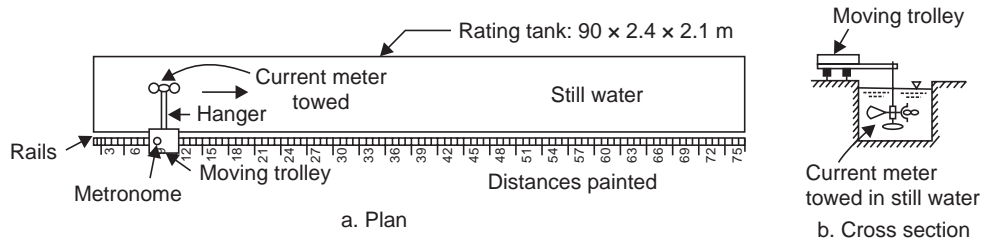

Fig. 6.4 Current meter rating tank

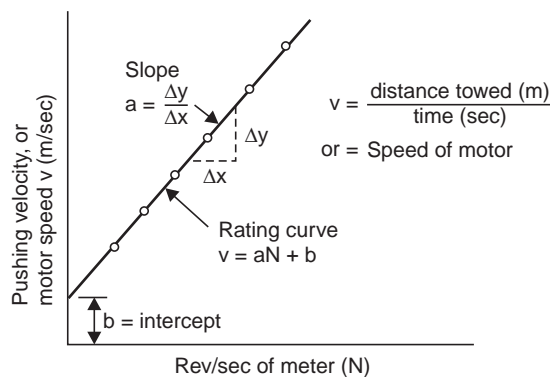

Fig. 6.5 Current meter rating curve

Stage-Discharge-Rating Curve

Once the rating equation of the current meter is known, actual stream gauging can be done from bridges, cradle, boat or launch. The cross section of the stream at the gauging site is divided into elemental strips of equal width *b* and the current meter is lowered to a depth of 0.6 *d* below water surface in shallow depths (one-point method) and to depths of 0.2*d* and 0.8*d*

(two-points method) in deep waters, at the centre of each strip, Fig. 6.6. The mean depth (d) at the centre of each strip is determined by sounding. The revolutions made by the meter in a known time at the appropriate depths are noted by an ear phone (connected through a wire to the penta or monocounter of the meter and the other to a dry cell) from which the velocities at the appropriate depths are determined from the rating equation, Eq. (6.7).

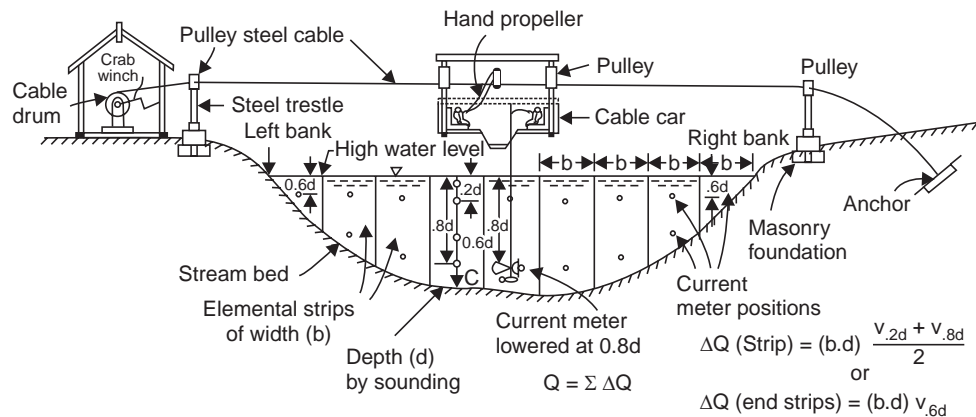

Fig. 6.6 Current meter gauging

It may be noted that the mean velocity is taken as that at $0.6d$ below water surface in shallow water (one-point method), and as the average of the velocities at $0.2d$ and $0.8d$ below the water surface (two-points method) in deep waters, as can be seen from the velocity distribution in a vertical in a stream section, Fig. 6.1 (b). The discharge in each elemental strip is determined and the discharge in the stream is the sum of the discharges in all the elemental strips.

There are two methods of determining the discharge in each elemental strip:

(i) *Mid-section method.* In this method, the vertical in which the velocity measurements are made (by one-point or two-points method) is taken as the middle of the strip, and the water depth (d) in the vertical (determined by sounding) is taken as the mean depth of the strip, Fig. 6.7 (a). If b is the width of strip (usually same for all strips) then the discharge in the elemental strip is given by

$$\Delta Q = (bd) v_{0.6d} \text{ in shallow strips} \quad \dots(6.8)$$

$$\Delta Q = (bd) \times \frac{v_{0.2d} + v_{0.8d}}{2} \text{ in deep water strips} \quad \dots(6.8 a)$$

$$\text{stream discharge,} \quad Q = \Sigma \Delta Q \quad \dots(6.8 b)$$

In this method, the discharge in the two-triangular bits near the ends are not included in the discharge computation.

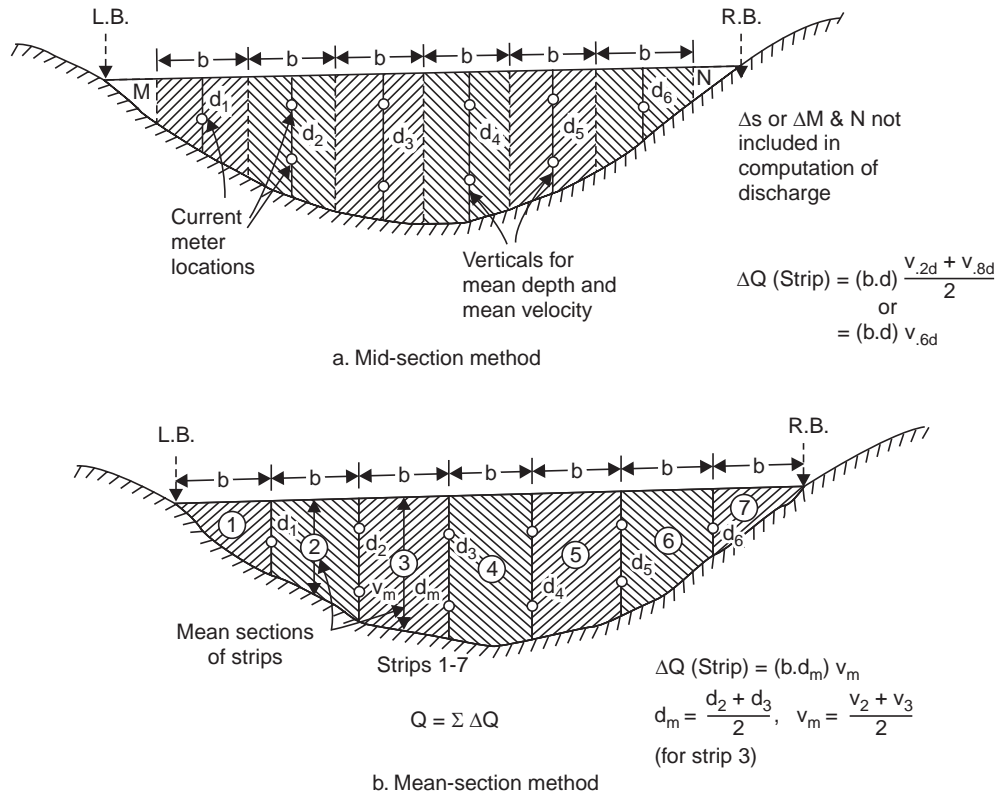

Fig. 6.7 Mid-section and Mean-section methods

(ii) *Mean-section method.* In this method, the elemental strip is taken between two verticals and the mean depth is taken as the average of the depths in the two verticals (determined by sounding). The width of the strip is distance b between the two verticals. The velocity in the strip is taken as the average of the mean velocity determined in the two verticals (by one-point or two-points method), Fig. 6.7 (b). The discharge in the elemental strip is given by

$$Q = b \left(\frac{d_1 + d_2}{2} \right) \left(\frac{V_1 + V_2}{2} \right) \quad \dots(6.9)$$

V_1, V_2 determined as $v_{0.6d}$ in shallow strip

and $\frac{v_{0.2d} + v_{0.8d}}{2}$ in deep water strip ... (6.9 a)

Stream discharge, $Q = \Sigma \Delta Q$... (6.9 b)

The mean section method is considered to be slightly more accurate, but the mid-section method is faster and is generally used.

Example 6.1 The following data were collected for a stream at a gauging station. Compute the discharge.

| Distance from one end of water surface (m) | depth, d (m) | Immersion of current meter below water surface | | | | | |
|--|----------------|--|------|-----------|------|-----------|------|
| | | at $0.6d$ | | at $0.2d$ | | at $0.8d$ | |
| | | Rev. | Sec. | Rev. | Sec. | Rev. | Sec. |
| 3 | 1.4 | 12 | 50 | | | | |
| 6 | 3.3 | | | 38 | 52 | 23 | 55 |
| 9 | 5.0 | | | 40 | 58 | 30 | 54 |
| 12 | 9.0 | | | 48 | 60 | 34 | 58 |
| 15 | 5.4 | | | 34 | 52 | 30 | 50 |
| 18 | 3.8 | | | 35 | 52 | 30 | 54 |
| 21 | 1.8 | 18 | 50 | | | | |

Rating equation of current meter: $v = 0.3 N + 0.05$, $N = rps$, $v =$ velocity, (m/sec), Rev.-Revolutions, Sec-time in seconds.

Solution The discharge in each strip, $\Delta Q = (bd) V$, where V is the average velocity in each strip, Fig. 6.8. In the first and the last strips (near the banks) where the depth is shallow, $V = v_{0.6d}$, and in the other five intermediate strips (with deep water), $V = \frac{v_{0.2d} + v_{0.8d}}{2}$. Width of each strip, $b = 3$ m, mean depth of strip = d , and the total discharge, $Q = \Sigma \Delta Q = 20.6$ cumec, as computed in Table 6.1.

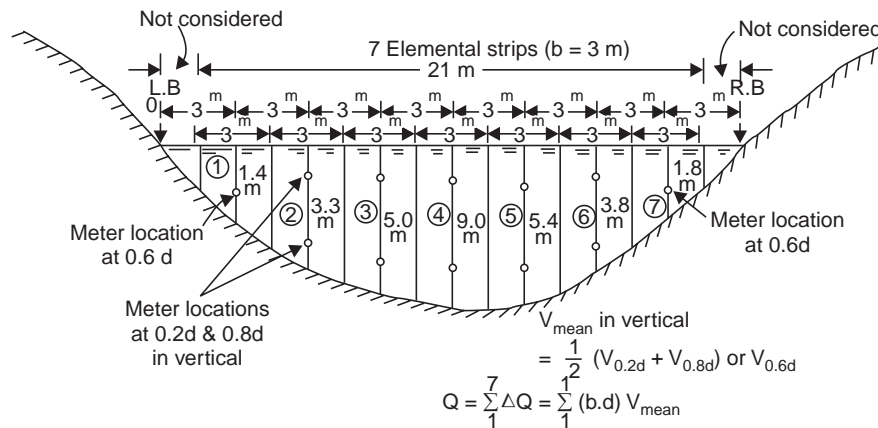

Fig. 6.8 Discharge computation (Example 6.1)

6.3 STAGE-DISCHARGE-RATING CURVE

A river is gauged by current meter throughout the rainy season (for about 3 months) at different stages (water levels) of the river. The water stage can be read on the enamel painted staff gauges (gauge posts) erected at different levels at a gauging station Fig. 6.9; it may be noted that corresponding graduation of gauge posts at two locations are fixed at the same level. A curve is drawn by plotting 'stream discharge Q vs. gauge height h ' which is called the 'stage-discharge rating curve' as shown in Fig. 6.10. From this rating curve, the stream discharge

Table 6.1 Current meter gauging of River. (Example 6.1)

| Distance from one end of water surface (m) | Depth, <i>d</i> (m) | Immersion of current meter below water surface | | | Average velocity in strip <i>V</i> (m/sec) | Discharge in strip $\Delta Q = (bd) V$ <i>b</i> = 3m |
|---|------------------------|---|------------------|--------------------------------|---|--|
| | | depth = <i>xd</i> (<i>x</i> = 0.6, 0.2, 0.8) (m) | Rev. <i>R</i> | <i>N</i> = <i>R/t</i> (rps) | | |
| 3 | 1.4 | 0.84 | 12 | 0.24 | 0.122 | 0.51 |
| 6 | 3.3 | 0.66 | 38 | 0.73 | 0.269* | 2.16 |
| | | 2.64 | 23 | 0.42 | 0.176 | |
| 9 | 5.0 | 1.00 | 40 | 0.69 | 0.257 | 3.54 |
| | | 4.00 | 30 | 0.56 | 0.218 | |
| 12 | 9.0 | 1.80 | 48 | 0.80 | 0.290 | 7.00 |
| | | 7.20 | 34 | 0.59 | 0.227 | |
| 15 | 5.4 | 1.08 | 34 | 0.65 | 0.245 | 3.85 |
| | | 4.32 | 30 | 0.60 | 0.230 | |
| 18 | 3.8 | 0.76 | 35 | 0.67 | 0.251 | 2.68 |
| | | 3.04 | 30 | 0.56 | 0.218 | |
| 21 | 1.8 | 1.08 | 18 | 0.36 | 0.158 | 0.86 |
| | | | | | Total <i>Q</i> = 20.60 cumec | |

* $\frac{0.269 + 0.176}{2} = 0.223$.

corresponding to staff gauge readings taken throughout the year/s can be obtained, as long as the section of the stream at or near the gauging site has not materially altered. Periodical gaugings (say, once in three years) are conducted to verify the rating curve, or to revise the rating curve if any change in section has been noticed.

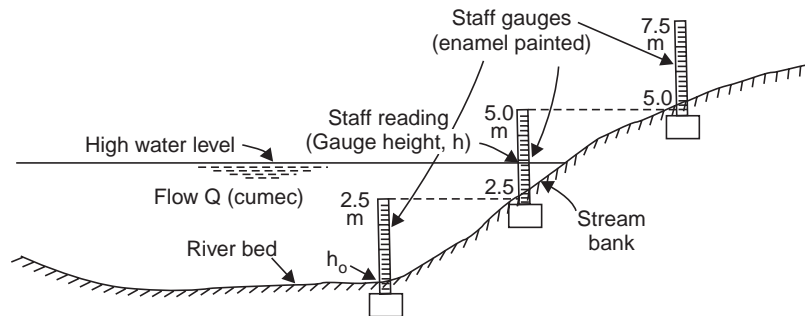

Fig. 6.9 Gauge posts on river bank

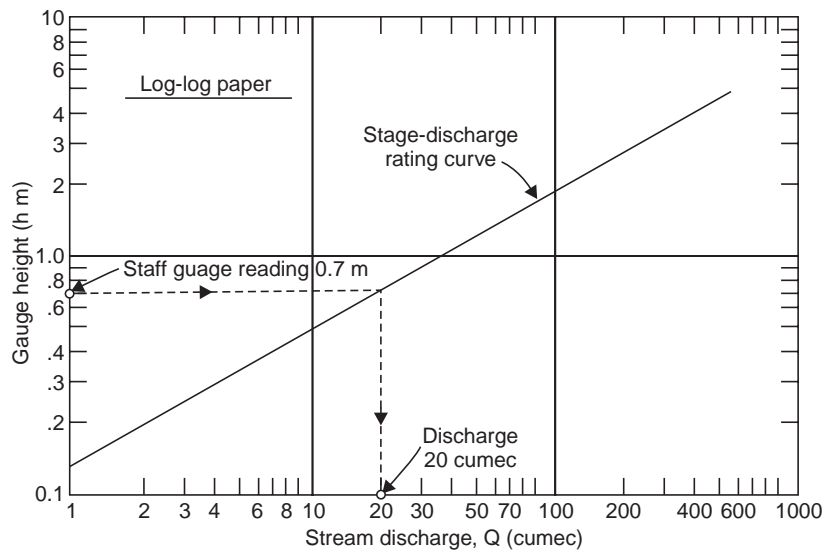

Fig. 6.10 Stage-discharge rating curve

For a continuous record of water stage (gauge heights or readings) during floods, an Automatic Water Stage Recorder (AWLR) is installed inside a gauge well on one of the banks of the stream at the gauging site, connected to the stream at different levels by pipes, Fig. 6.11. A steel wire rope with a float at one end and a counter weight at the other passes over a pulley connected to a cylindrical drum over which a chart is wrapped. The rise and fall of the float with the water level causes rotation of the drum while a clock mechanism moves a pen axially along the drum, thus producing a water stage hydrograph. The time scale on the graph is usually so chosen as to cover a week's period. Thus, a continuous record of the river stage with the time is obtained. The water level in well is not subject to fluctuations caused by wind or waves.

If the river is subject to scour, the well should be sufficiently deep and the zero of the gauge should be sufficiently below the bed, so that the water surface will not come below the

bottom of the well or below the zero gauge reading due to scour of the river bed. Thus, the gauge height (gauge reading) corresponding to zero discharge varies according to the degree of scour or deposition but is always a positive number (h_0).

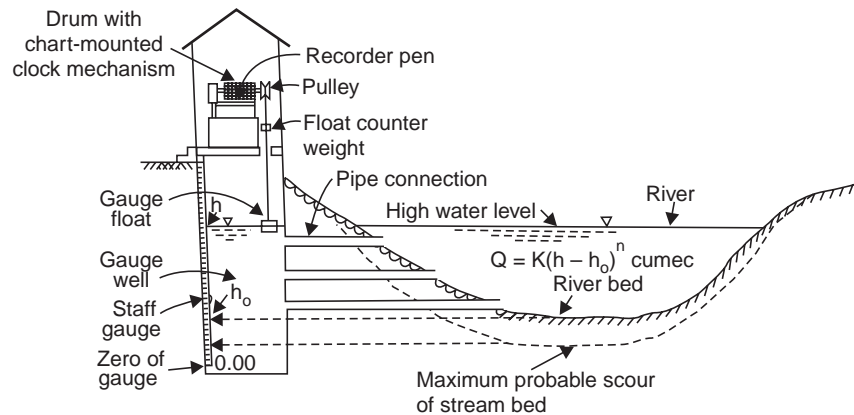

Fig. 6.11 River stage recorder

Extension of Stage-Discharge Rating Curve

If h_0 is the gauge reading corresponding to zero-discharge and h is the gauge reading when the discharge is Q , the gauge height is $(h - h_0)$ for this discharge Q . The relation between stream discharge and gauge height can be expressed as

$$Q = K (h - h_0)^n \quad \dots(6.10)$$

where K and n are the constants for any stream gauging station.

$$\underbrace{\log Q}_y = \underbrace{\log K}_c + \underbrace{n}_m \underbrace{\log (h - h_0)}_x \quad \dots(6.10 a)$$

Hence, the plot of Q vs. $(h - h_0)$ on a log-log paper gives a straight line whose slope is n and $K = Q$ when $(h - h_0) = 1$, Fig. 6.12.

Usually the value of h_0 is not known and the observations made are values of Q corresponding to gauge readings h . Then, h_0 is determined by assuming trial values; for example for assumed value of $h_0 = 1.2$, the discharge rating curve is concave upward and for a value of $h_0 = 0.6$ the curve is concave downward; for some intermediate value $h_0 = 0.9$, it is a straightline plot and can be extended to higher stages once the value of h_0 is determined, the scale of $(h - h_0)$ may be replaced by gauge reading h , since $h = (h - h_0) + 0.9$, to facilitate direct reading of stream discharge for any observed gauge reading h . It is customary to plot the rating curve with Q as abscissa and h as ordinate, Fig. 6.10.

Adjustment of Stage-Discharge Rating Curve

When discharge measurements are made during both rising and falling stages and also at constant stage, the points joining the rising and falling stages plot a loop due to channel storage and variation of water surface slope as a flood wave moves along the stream, Fig. 6.13. A smooth discharge curve is then drawn along the median line passing through or near the points that were obtained at constant stage. Whenever stream gauging is conducted for determining or checking the discharge-rating curve, the gauge reading and time are recorded at the

beginning and at the end of the gauging to calculate the rate of change in stage. Curves-relating percentage correction to discharge and rate of change in stage can be obtained from continuous discharge measurement during rising, falling and constant stages of the river.

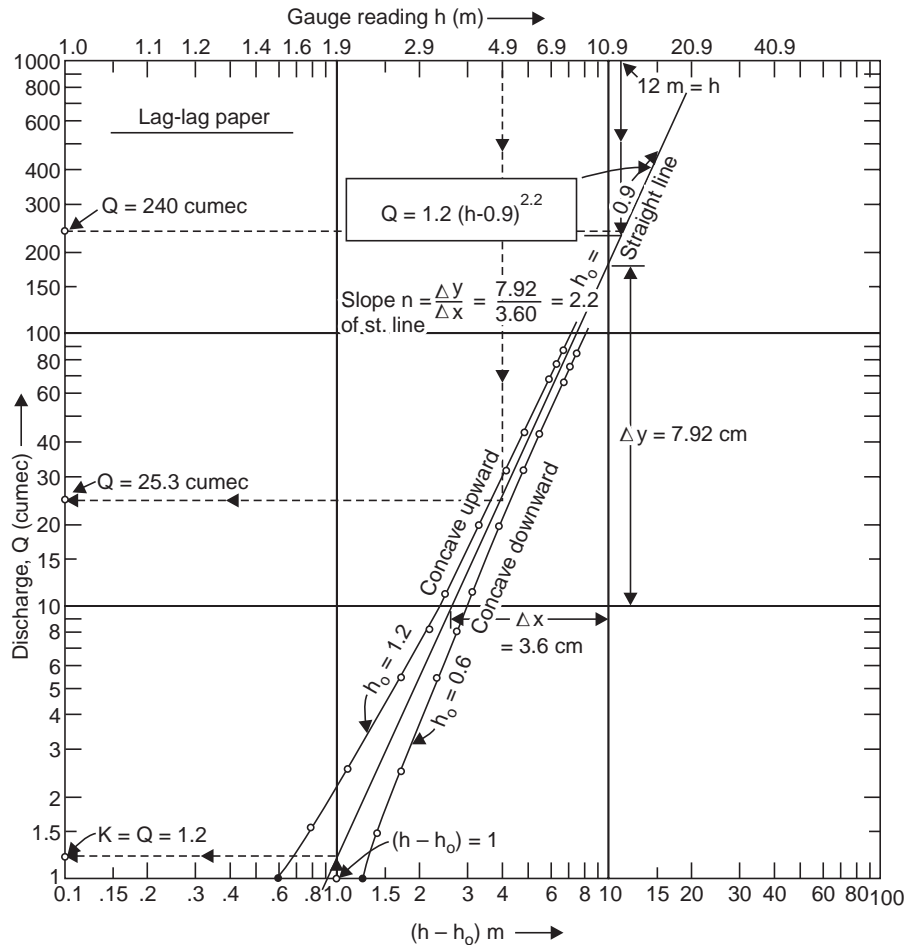

Fig. 6.12 Extension of stage-discharge-rating curve (Example 6.2)

Correction has to be applied for the discharge obtained from the rating curve during a rising or falling stage *i.e.*, during a flood. For this purpose, an auxiliary gauge is established some distance upstream or downstream from the main gauge (Fig. 6.14). If Q_0 is the discharge when Δh_0 is the difference of gauge readings between the main and auxiliary gauges during normal flow, and Q_a is the discharge when Δh_a is the difference of the two gauges during a rising or falling stage then

$$\frac{Q_a}{Q_0} = \left(\frac{\Delta h_a}{\Delta h_0} \right)^n \quad \dots(6.11)$$

where the exponent $n \approx 0.5$, since Q varies as the square root of the energy gradient, which in turn varies with Δh , the distance between the gauges being constant.

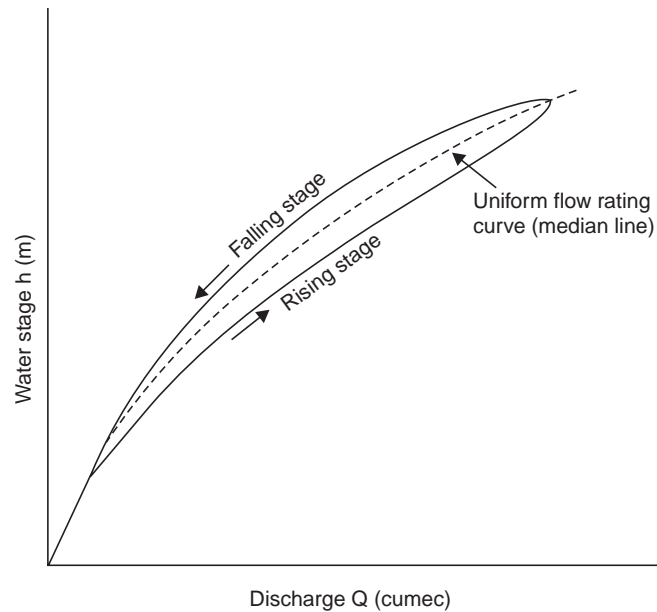

Fig. 6.13 Adjustment of flow rating curve

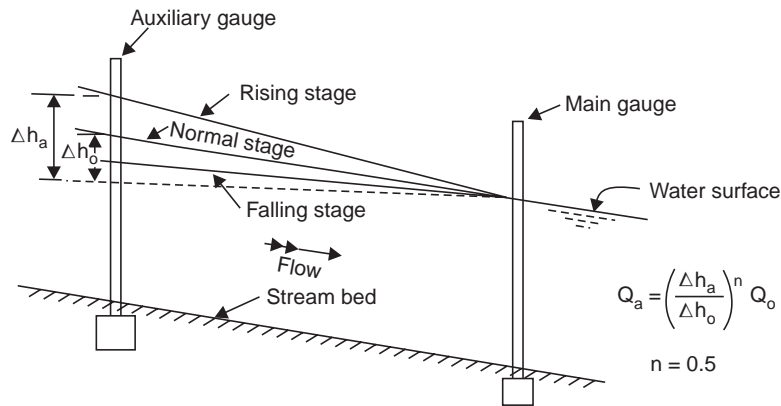

Fig. 6.14 Auxiliary gauge for flow adjustment

From Eq. (6.11) the actual discharge Q_a during a rising or falling stage can be determined. The distance between the two gauges should be such that Δh_o is at least 0.3 m, to avoid observational errors.

6.4 SELECTION OF SITE FOR A STREAM GAUGING STATION

The following factors have to be considered in selecting a site for a stream gauging station.

- (i) The section should be straight and uniform for a length of about 10 to 20 times the width of the stream.
- (ii) The bed and banks of the stream should be firm and stable so as to ensure consistency of area-discharge relationship, *i.e.*, the cross section should not be subjected to change by

silting or scouring, during different stages of flow; a smooth rock, shingle or clay bed is favourable, while a fine sandy bed is unfavourable.

(iii) The bed and banks should be free from vegetal growth, boulders or other obstructions like bridge piers, etc.

(iv) There should be no larger overflow section at flood stage. The best cross section is one with V-shape, so that there is sufficient depth for immersing the current meter without being affected by the bed roughness of the stream.

(v) The part of the reach having the most regular transverse section and steady flow with the current normal to the metering section and velocities in the range of 0.3–1.2 m/sec should be selected.

(vi) To ensure consistency between stage and discharge, there should be a good control section far downstream of the gauging site. This control may be in the form of steep rapids, large rocky boulders, restricted passages, crest of weirs or anicuts etc.

(vii) The sites above the confluence of rivers are best avoided if the flow is affected by back water conditions due to the varying discharges in the tributaries.

(viii) The stream gauging station should be easily accessible.

Example 6.2 *The stream discharges for various stages at a particular section were observed to be as follows. Obtain an equation for the stage-discharge relationship and determine the discharge for a stage of 4.9 m and 12 m.*

| | | | | | | |
|-------------------|-------|-------|------|------|-------|-------|
| Stage (m) | 1.81 | 2.00 | 2.30 | 2.90 | 3.70 | 4.50 |
| Discharge (cumec) | 1.00 | 1.50 | 2.55 | 5.60 | 11.70 | 20.20 |
| Stage (m) | 5.40 | 6.10 | 7.30 | 7.70 | 8.10 | |
| Discharge (cumec) | 32.50 | 44.50 | 70.0 | 80.0 | 90.0 | |

Solution The relation between the stage (h) and discharge (Q) of the stream can be assumed of the form

$$Q = K(h - a)^n, \text{ (similar to Eq. (6.10))}$$

where K , a and n are the constants. Plot Q vs. $(h - a)$ on a log-log paper assuming a value for the constant $a = 0.6$ m (say); the curve obtained is concave downwards, Fig. 6.12. Now assume a value $a = 1.2$ m (say) and the curve obtained is concave upward. Now try an intermediate value $a = 0.9$ m, which plots a straight line and represents the stage discharge relationship. The slope of this straight line gives the value of the exponent $n = 2.2$, and from the graph for $h - a = 1$, $Q = 1.2 = K$. Now the constants are determined and the equation for the stage-discharge relationship is

$$Q = 1.2(h - 0.9)^{2.2}$$

It may be noted that the value of $a = 0.9$, which gives a straight line plot is the gauge reading for zero discharge. Now the abscissa of $(h - a)$ may be replaced by the gauge reading (stage) h , by adding the value of 'a' to $(h - a)$ values. For example the $(h - a)$ values of 0.1, 1, 2, 4, 6, 8 and 10 may be replaced by the h values of 1, 1.9, 2.9, 4.9, 6.9, 8.9 and 10.9 respectively. Now for any gauge reading (stage) h , the discharge Q can be directly read from the graph and the stage discharge curve can be extended. From the graph, Fig. 6.12,

$$\text{for } h = 4.9 \text{ m, } Q = 25.3 \text{ cumec}$$

and for $h = 12.0$ m, $Q = 240$ cumec

which can be verified by the stage-discharge equation obtained as

for $h = 4.9$ m, $Q = 1.2 (4.9 - 0.9)^{2.2} = 25.3$ cumec

for $h = 12$ m, $Q = 1.2 (12 - 0.9)^{2.2} = 240$ cumec

Note The equation for the stage-discharge relation can also be obtained by ‘Linear Regression’ by assuming trial values of ‘a’ and computer-based numerical analysis. See chapter—13.

Example 6.3 The following data were obtained by stream gauging of a river:

| | | |
|-----------------------------------|-------|-------|
| Main gauge staff reading (m) | 12.00 | 12.00 |
| Auxiliary gauge staff reading (m) | 11.65 | 11.02 |
| Discharge (cumec) | 9.50 | 15.20 |

what should be the discharge when the main gauge reads 12 m and the auxiliary gauge reads 11.37 m?

Solution

$$\Delta h_0 = 12.00 - 11.65 = 0.35 \text{ m}$$

$$\Delta h_a = 12.00 - 11.02 = 0.98 \text{ m}$$

$$\text{Eq. (6.10): } \frac{Q_a}{Q_0} = \left(\frac{\Delta h_a}{\Delta h_0} \right)^n \quad \frac{15.20}{9.50} = \left(\frac{0.98}{0.35} \right)^n$$

$$\therefore n = 0.5125$$

Again, when the auxiliary gauge reads 11.37 m,

$$\Delta h_a = 12.00 - 11.37 = 0.63 \text{ m}$$

$$\frac{Q_a}{9.50} = \left(\frac{0.63}{0.35} \right)^{0.5125}$$

$$\therefore Q_a = 12.85 \text{ cumec}$$

Example 6.4 A bridge has to be constructed over a river, which receives flow from three branches above the site. Compute the maximum flood discharge at the bridge site from the following data:

Branch 1 has a bridge:

| | |
|--|---------|
| Width of natural water way | 324.0 m |
| Lineal water way under the bridge (with $C_d = 0.95$ for rounded entry) | 262.5 m |
| Depth upstream of bridge | 4.6 m |
| Depth downstream of bridge | 2.8 m |

Branch 2 has a catchment area of 4125 km²

Ryve’s C = 10

Branch 3 levelling of cross section (cls) data:

| | | | | | | | |
|----------------------|------|-----|-----|-----|-----|------|------|
| Distance from BM (m) | 0 | 11 | 24 | 52 | 67 | 79 | 84 |
| RL on cls (m) | 10.8 | 9.6 | 4.2 | 2.4 | 5.4 | 10.2 | 10.5 |

Levelling of longitudinal-section (L/S) data:

| | | | |
|------------------------------|------------------|-------------------|--------------------|
| Distance from bridge site | 1 km upstream | at bridge site | 1 km downstream |
| HFL along L/S (m) | 9.60 | 9.0 | 8.39 |

Manning’s n may be assumed at 0.03.

Solution (i) Discharge from Branch 1, *i.e.*, Q_1 under bridge openings, Fig. 6.15, from Eq. (6.3)

$$Q_1 = C_d A_1 \sqrt{2g(\Delta h + h_a)}$$

If L , d , V and L_1 , d_1 , V_1 refer to the length, mean depth and velocity of the normal stream (upstream of bridge site) and those under the contracted section of the bridge and also

$$A_1 = L_1 d, \quad Q_1 = L d V, \quad h_a = \frac{V^2}{2g}$$

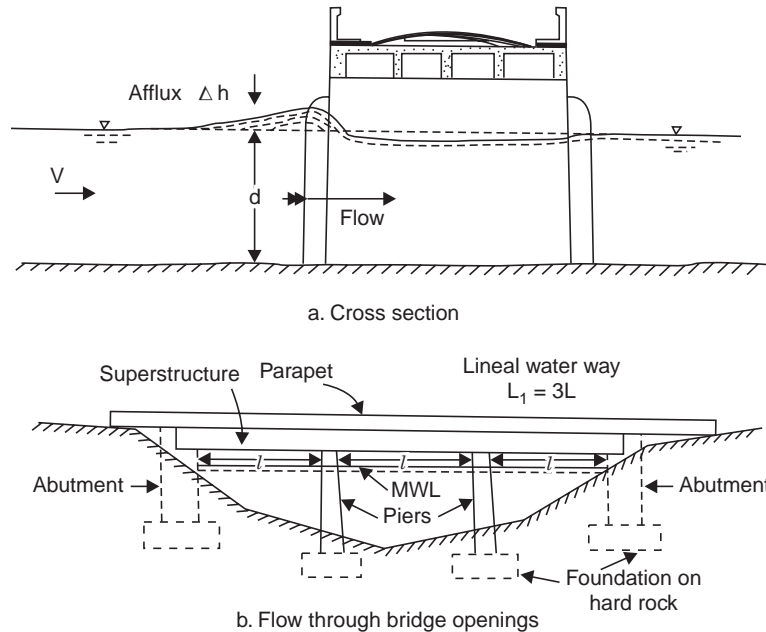

Fig. 6.15 Flow through bridge openings (Example 6.4)

Eq. (6.3) after substitution and simplification yields the expression for afflux (*i.e.*, heading up of water on the upstream face of the bridge openings) as

$$\text{Afflux } \Delta h = \frac{V^2}{2g} \left(\frac{L^2}{C_d^2 L_1^2} - 1 \right) \quad \dots(6.12)$$

If the Branch 1, flow under bridge openings

$$4.6 - 2.8 = \frac{V^2}{2 \times 9.81} \left(\frac{324^2}{0.95^2 \times 262.5^2} - 1 \right)$$

$$\therefore V = 7.16 \text{ m/sec}$$

$$Q_1 = L d V = 324 \times 2.8 \times 7.16 = 6500 \text{ cumec}$$

(ii) Discharge from Branch 2:





From Ryve's formula (see Eq. 8.2)

$$Q_2 = C A^{2/3} \quad \dots(6.13)$$

$$= 10 (4125)^{2/3} = 2580 \text{ cumec}$$

(iii) Discharge from Branch 3 (from slope-area method): See Table 6.2 for computation C/S area and wetted perimeter, Fig. 6.16.

Table 6.2 Computation C/S area and wetted perimeter (Fig. 6.16)

| Area no. | Area shape | Area, A_1 (m^2) | Wetted perimeter, P_1 (m) |
|----------|---|---|---------------------------------|
| 1. |  | $\frac{1}{2} \times 11.55 \times 4.8 = 27.75$ | $\sqrt{11.55^2 + 4.8^2} = 12.5$ |
| 2. |  | $\frac{1}{2} (4.8 + 6.6) 28 = 159.60$ | $\sqrt{28^2 + 1.8^2} = 28.2$ |
| 3. |  | $\frac{1}{2} (6.6 + 3.6) 15 = 76.50$ | $\sqrt{15^2 + 3^2} = 15.2$ |
| 4. |  | $\frac{1}{2} \times 9 \times 3.6 = 16.20$ | $\sqrt{9^2 + 3.6^2} = 9.7$ |
| | | $A = 280.05$ | $P = 65.6$ |

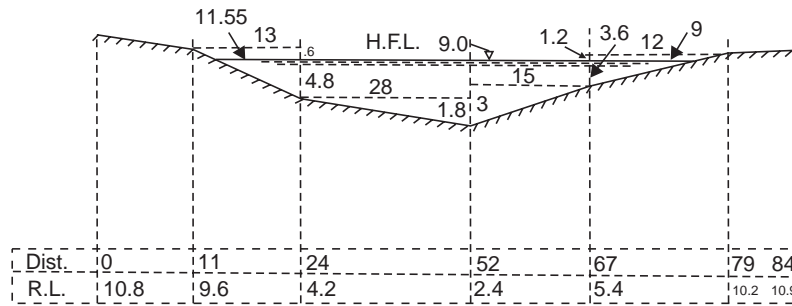

Fig. 6.16 Cross section of river at bridge site (Example 6.4)

Hydraulic mean radius, $R = \frac{A}{P} = \frac{280.05}{65.6} = 4.27 \text{ m}$

Water surface slope, $S = \frac{\Delta h}{L} = \frac{9.60 - 8.39}{2 \times 1000} = \frac{1}{1652}$

By Manning's formula, the velocity of flow

$$V = \frac{1}{n} R^{2/3} S^{1/2} = \frac{1}{0.03} (4.27)^{2/3} \frac{1}{1652}^{1/2} = 2.16 \text{ m/sec}$$

$\therefore Q_3 = AV = 280.05 \times 2.16 = 605 \text{ cumec}$

Discharge at bridge site

$$Q = Q_1 + Q_2 + Q_3 = 6500 + 2580 + 605 = 9685 \text{ cumec}$$

QUIZ VI

I Choose the correct statement/s

The method of measuring discharge in a turbulent stream is

- (i) by measuring the drop in water surface under bridge openings and canal falls.

- (ii) by adding common salt into flowing water and determining its concentration downstream.
- (iii) by slope-area method.
- (iv) by area-velocity method.
- (v) by measuring head over weirs or anicuts.
- (vi) by measuring the upstream depth in a standing wave flume.

II Match the items in 'A' with the items in 'B'

- | A | B |
|-----------------------------------|--|
| (i) Area-velocity method | (a) Afflux |
| (ii) Slope-area method | (b) Turbulent streams |
| (iii) Bridge openings | (c) Mean velocity |
| (iv) Salt-concentration method | (d) $v = aN + b$ |
| (v) Surface and subsurface floats | (e) $Q = K(h - a)^n$ |
| (vi) Velocity rods | (f) AWLR |
| (vii) Current-meter rating | (g) Control section downstream |
| (viii) Stage-discharge curve | (h) Peak flood where no gauging station exists |
| (ix) River stage | (i) Current-meter gauging |
| (x) Stream gauging site | (j) Surface velocity |

III Say 'true' or 'false', if false, give the correct statement:

- (i) The staff-gauge reading corresponding to zero-discharge in a stream is always a positive number.
- (ii) The mean velocity in a vertical stream can be calculated by measuring the velocities at one-fifth and four-fifths of the depth of the stream in that vertical.
- (iii) While the surface and subsurface floats measure the mean velocity of the stream, the velocity rods measure the surface velocity.
- (iv) Subsurface floats will not give the velocity accurately since they are affected by wind.
- (v) Discharge in a river can not be determined by measurement near bridge openings.
- (vi) The salt-concentration method can best be used to determine the discharge of non-turbulent rivers.
- (vii) The hydraulic turbine can be used as a good water meter.
- (viii) The stream gauging site should be on the upstream of the confluence of rivers.
- (ix) There should be a good-control section immediately upstream of the gauging site.
- (x) The calibration of the current meter is called the *current meter rating* while the stage-discharge is the relation between the staff-gauge reading and the stream discharge.
- (xi) If the stage-discharge relation is governed by the slope, size and roughness of the channel over a considerable distance, the station is under channel control.
- (xii) A pressure transducer may be used to obtain:
 - (a) a stage-hydrograph.
 - (b) a discharge-hydrograph.
- (xiii) The slope-area method is often used to estimate peak floods near the existing gauging station.

(false: ii, iv, v, vi, viii, ix, xiii)

QUESTIONS

- 1 (a) What are the factors that influence the selection of a site for a stream gauging station?
 (b) Explain how the stage-discharge-rating curve for a stream-gauging station is prepared. Sketch a typical rating curve. What are the sources of error in getting the discharge from the rating curve?
- 2 (a) What equipment will you use for making velocity measurements in a stream? Explain.
 (b) Velocity measurements are to be made at a vertical in a stream. At what height or heights from the bed, will you make the measurements to determine the mean in vertical velocity by:
 (i) one-point method, and (ii) by two-points method?
- 3 (a) What is a flow rating curve? Explain its use. Sketch a typical flow rating curve.
 (b) Following velocities were recorded in a stream with a current meter.

| | | | | | |
|-----------------------------|---|-----|-----|-----|-----|
| <i>Depth above bed (m):</i> | 0 | 1 | 2 | 3 | 4 |
| <i>Velocity (m/sec):</i> | 0 | 0.5 | 0.7 | 0.8 | 0.8 |

Find the discharge per unit width of stream near the point of measurement. Depth of flow at the point was 5 m. (3.75 cumec)

- 4 (a) Explain briefly the method of stream gauging by area-velocity method.
 (b) The following data were collected for a stream at a gauging station. Compute the discharge by (i) mid-section method (ii) mean-section method.

| <i>Distance from one end of water surface (m)</i> | <i>Depth of water (m)</i> | <i>Velocity (m/sec)</i> | | |
|---|---------------------------|-------------------------|----------------|----------------|
| | | <i>at 0.6d</i> | <i>at 0.2d</i> | <i>at 0.8d</i> |
| 0 | 0 | — | — | — |
| 1.2 | 0.7 | 0.4 | — | — |
| 2.4 | 1.7 | | 0.7 | 0.5 |
| 3.6 | 2.5 | | 0.9 | 0.6 |
| 4.8 | 1.3 | | 0.6 | 0.4 |
| 6.0 | 0.5 | 0.35 | | |
| 7.2 | 0 | — | — | — |

(4.8, 4.442 cumec)

- 5 (a) Explain: 'current metre rating curve'. How it is prepared ? Sketch a typical rating curve.
 (b) What do you understand by the term 'control point' with reference to a stream gauging station?
 - 6 The staff gauge readings and the corresponding discharges measured in a stream are given below. Assuming the relationship to be exponential, fit an equation by drawing a graph. What is the discharge for a staff gauge reading of 1.6 m and 2.5 m?
- | | | | | | | | |
|---------------------------|------|------|------|------|------|------|------|
| <i>Gauge reading (m):</i> | 0.40 | 0.70 | 1.09 | 1.28 | 1.49 | 1.83 | 2.32 |
| <i>Discharge (cumec):</i> | 24 | 47 | 80 | 98 | 121 | 163 | 268 |
- 7 The following data were collected for two verticals in a stream at a gauging station. Compute the discharge in the elemental strips by
 (i) the mid-section method (ii) the mean-section method

| Distance from one end of water surface (m) | Depth, d (m) | Immersion of current meter below water surface (m) | | | |
|---|-------------------|---|-----|-----------|-----|
| | | at $0.2d$ | | at $0.8d$ | |
| | | rev | sec | rev | sec |
| 3 | 0.8 | 135 | 150 | 97 | 151 |
| 6 | 1.2 | 150 | 100 | 150 | 138 |

Rating equation of the current meter; $v = 0.7 N + 0.03$ where $N = \text{rev./sec}$, $v = \text{velocity (m/sec)}$.

- 8 The following data are obtained from the current meter gauging of a stream, at a gauging station. Compute the stream discharge.

| Distance from one end of water surface (m) | Depth of water, d (m) | Immersion of current meter below water surface | | |
|--|----------------------------|---|-----|-----|
| | | depth (m) | rev | sec |
| 0 | 0 | — | — | — |
| 2 | 1.0 | 0.6 | 10 | 40 |
| 4 | 2.2 | 0.44 | 36 | 48 |
| | | 1.76 | 20 | 50 |
| 6 | 4.0 | 0.80 | 40 | 57 |
| | | 3.20 | 30 | 53 |
| 8 | 8.0 | 1.6 | 46 | 59 |
| | | 6.4 | 33 | 57 |
| 10 | 4.2 | 0.84 | 33 | 51 |
| | | 3.36 | 29 | 49 |
| 12 | 2.5 | 0.50 | 34 | 52 |
| | | 2.00 | 29 | 53 |
| 14 | 1.2 | 0.72 | 16 | 48 |
| 16 | 0 | — | — | — |

Rating equation of current meter: $v = 0.2 N + 0.04$, where $N = \text{rev./sec}$, $v = \text{velocity (m/sec)}$.

9. A surface float took 10 sec to travel a straight run of a stream of 20 m. What is the approximate mean velocity of the stream? If a velocity rod had been used, what time it would have taken to travel the same run. (1.7 m/sec, 11.8 sec)
10. (a) What is the effect of rising or falling stage upon the discharge-curve?
 (b) The following data are obtained by stream gauging of a river:
- | | | |
|-----------------------------------|------|------|
| Main gauge staff reading (m) | 9.6 | 9.6 |
| Auxiliary gauge staff reading (m) | 9.32 | 8.63 |
| Discharge (cumec) | 4.50 | 8.45 |

What should be the discharge when the main gauge reads 9.6 m and the auxiliary gauge reads 9.02 m? (6.55 cumec)

11. Write a note on 'stream gauging with shifting control'.

12. The cross section (C/S) of a river is as follows:

| | | | | | | | | |
|---------------------------------|-------|------|-------|-------|-------|-------|-------|-------|
| <i>Distance from BM (m)</i> | 0 | 10 | 20 | 30 | 40 | 50 | 60 | 70 |
| <i>Reduced level on C/S (m)</i> | 46.70 | 44.5 | 42.80 | 42.10 | 42.70 | 42.70 | 44.00 | 46.80 |

Longitudinal section (L/S) is as follows:

| | | | |
|--------------------------|---------------|----------------|-----------------|
| <i>Distance (m)</i> | 1 km upstream | at bridge site | 1 km downstream |
| <i>HFL along L/S (m)</i> | 45.10 | 44.50 | 43.89 |

Manning's n may be assumed as 0.03.

A bridge is proposed across the river. Calculate the high flood discharge at bridge site.

13. A bridge is proposed across a stream which has a catchment area of 3200 km². Ryve's coefficient of $C = 10$ applies. Compute the maximum flood discharge at bridge site.

14. The following are the measurements at a bridge site, during floods. Compute the maximum flood discharge at bridge site:

| | |
|-----------------------------------|--------|
| Width of natural water way | 284 m |
| Lineal water way under the bridge | 227 m |
| For rounded entry take C_d as | 0.95 |
| Depth upstream of bridge | 4.80 m |
| Depth downstream of bridge | 3.00 m |

Chapter 7

GROUND WATER

7.1 TYPES OF AQUIFERS AND FORMATIONS

Ground water is widely distributed under the ground and is a replenishable resource unlike other resources of the earth. The problems in Ground Water Investigation are the zones of occurrence and recharge. The modern trends are to create more opportunity for recharge of ground water from natural sources like rain, percolation dams, etc. The ground water is free from pollution and the ground water storage is free from atomic attacks. Ground water can be developed at a small capital cost in least possible time, and intensive irrigation can be practised with double and tripple cropping including commercial crops; ground water can be used for supplemental irrigation during periods of deficient surface supply, for the year-round irrigation practice.

A water bearing geologic formation or stratum capable of transmitting water through its pores at a rate sufficient for economic extraction by wells is called 'aquifer'. Formations that serve as good aquifers are:

- unconsolidated gravels, sands, alluvium
- lake sediments, glacial deposits
- sand stones
- limestones with cavities (caverns) formed by the action of acid waters (solution openings in limestones and dolomites)
- granites and marble with fissures and cracks, weathered gneisses and schists
- heavily shettered quartzites
- vesicular basalts
- slates (better than shales owing to their jointed conditions)

A geologic formation, which can absorb water but can not transmit significant amounts is called an 'aquiclude'. Examples are clays, shales, etc.

A geologic formation with no interconnected pores and hence can neither absorb nor transmit water is called an 'aquifuge'. Examples are basalts, granites, etc.

A geologic formation of rather impervious nature, which transmits water at a slow rate compared to an aquifer (insufficient for pumping from wells) is called an 'aquitard'. Examples are clay lenses interbedded with sand.

Specific yield. While porosity (n) is a measure of the water bearing capacity of the formation, all this water can not be drained by gravity or by pumping from wells as a portion of water is held in the void spaces by molecular and surface tension forces. The volume of water,

expressed as a percentage of the total volume of the saturated aquifer, that will drain by gravity when the water table (Ground Water Table (GWT)) drops due to pumping or drainage, is called the 'specific yield (S_y)' and that percentage volume of water, which will not drain by gravity is called 'specific retention (S_r)' and corresponds to 'field capacity' *i.e.*, water holding capacity of soil (for use by plants and is an important factor for irrigation of crops). Thus,

porosity = specific yield + specific retention

$$n = S_y + S_r \quad \dots(7.1)$$

Specific yield depends upon grain size, shape and distribution of pores and compaction of the formation. The values of specific yields for alluvial aquifers are in the range of 10–20% and for uniform sands about 30%.

7.2 CONFINED AND UNCONFINED AQUIFERS

If there is homogeneous porous formation extending from the ground surface up to an impervious bed underneath (Fig. 7.1), rainwater percolating down in the soil saturates the formation and builds up the ground water table (GWT). This aquifer under water table conditions is called an *unconfined aquifer* (water-table aquifer) and well drilled into this aquifer is called a *water table well*.

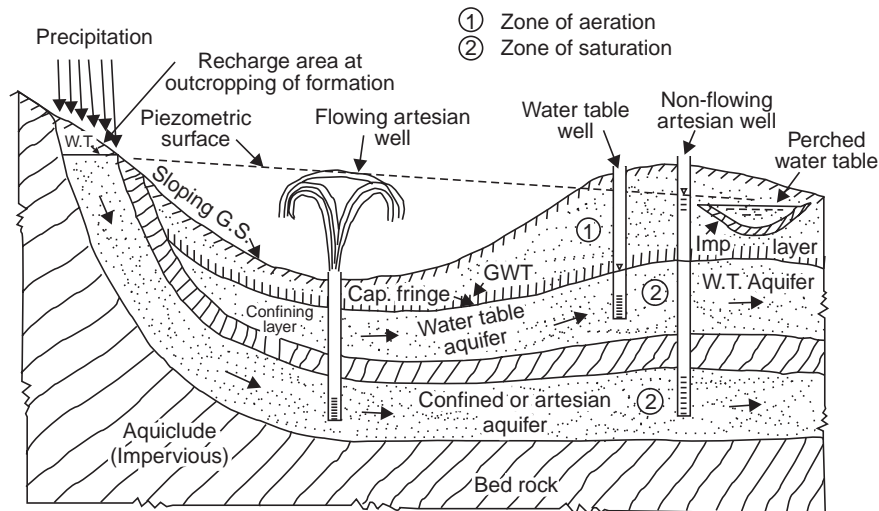

Fig. 7.1 Types of aquifers and location of wells

On the other hand, if a porous formation underneath is sandwiched between two impervious strata (aquicludes) and is recharged by a natural source (by rain water when the formation outcrops at the ground surface—recharge area, or outcrops into a river-bed or bank) at a higher elevation so that the water is under pressure in the aquifer (like pipe flow), *i.e.*, artesian condition. Such an aquifer is called an artesian aquifer or confined aquifer. If a well is drilled into an artesian aquifer, the water level rises in the well to its initial level at the recharge source called the *piezometric surface*. If the piezometric surface is above the ground level at the location of the well, the well is called 'flowing artesian well' since the water flows out of the well like a spring, and if the piezometric surface is below the ground level at the well location, the well is called a non-flowing artesian well. In practice, a well can be drilled through 2-3 artesian aquifers (if multiple artesian aquifers exist at different depths below ground level).

Sometimes a small band of impervious strata lying above the main ground water table (GWT) holds part of the water percolating from above. Such small water bodies of local nature can be exhausted quickly and are deceptive. The water level in them is called ‘perched water table’.

Storage coefficient. The volume of water given out by a unit prism of aquifer (*i.e.*, a column of aquifer standing on a unit horizontal area) when the piezometric surface (confined aquifers) or the water table (unconfined aquifers) drops by unit depth is called the *storage coefficient* of the aquifer (S) and is dimensionless (fraction). It is the same as the volume of water taken into storage by a unit prism of the aquifer when the piezometric surface or water table rises by unit depth. In the case of water table (unconfined) aquifer, the storage coefficient is the same of specific yield (S_y).

Since the water is under pressure in an artesian aquifer, the storage coefficient of an artesian aquifer is attributable to the compressibility of the aquifer skeleton and expansibility of the pore water (as it comes out of the aquifer to atmospheric pressure when the well is pumped) and is given by the relation.

$$S = \gamma_w nb \left(\frac{1}{K_w} + \frac{1}{nE_s} \right) \quad \dots(7.2)$$

where S = storage coefficient (decimal)

γ_w = specific weight of water

n = porosity of soil (decimal)

b = thickness of the confined aquifer

K_w = bulk modulus of elasticity of water

E_s = modulus of compressibility (elasticity) of the soil grains of the aquifer.

Since water is practically incompressible, expansibility of water as it comes out of the pores has a very little contribution to the value of the storage coefficient.

The storage coefficient of an artesian aquifer ranges from 0.00005 to 0.005, while for a water table aquifer $S = S_y = 0.05-0.30$. The specific yield (unconfined aquifers) and storage coefficient (confined aquifers), values have to be determined for the aquifers in order to make estimates of the changes in the ground water storage due to fluctuation in the GWT or piezometric surface (ps) from the relation.

$$\Delta GWS = A_{aq} \times \Delta GWT \text{ or } ps \times S \text{ or } S_y \quad \dots(7.3)$$

where ΔGWS = change in ground water storage

A_{aq} = involved area of the aquifer

ΔGWT or ps = fluctuation in GWT or ps

S or S_y = storage coefficient (confined aquifer) or specific yield (unconfined aquifer).

Example 7.1 In a certain alluvial basin of 100 km^2 , 90 Mm^3 of ground water was pumped in a year and the ground water table dropped by about 5 m during the year. Assuming no replenishment, estimate the specific yield of the aquifer. If the specific retention is 12%, what is the porosity of the soil?

Solution (i) Change in ground water storage

$$\Delta GWS = A_{aq} \times \Delta GWT \times S_y$$

$$90 \times 10^6 = (100 \times 10^6) \times 5 \times S_y$$

$$\therefore S_y = 0.18$$

$$(ii) \text{ Porosity } n = S_y + S_r = 0.18 + 0.12 = 0.30. \text{ or } 30\%$$

Example 7.2 An artesian aquifer, 30 m thick has a porosity of 25% and bulk modulus of compression 2000 kg/cm². Estimate the storage coefficient of the aquifer. What fraction of this is attributable to the expansibility of water?

Bulk modulus of elasticity of water = 2.4 × 10⁴ kg/cm².

$$\begin{aligned} \text{Solution } S &= \gamma_w nb \left(\frac{1}{K_w} + \frac{1}{nK_s} \right) = 1000 \times 0.25 \times 30 \left(\frac{1}{2.14 \times 10^8} + \frac{1}{0.25 \times 2 \times 10^7} \right) \\ &= 7500 (0.467 \times 10^{-8} + 20 \times 10^{-8}) = 1.54 \times 10^{-3} \end{aligned}$$

Storage coefficient due to the expansibility of water as a percentage of *S* above

$$= \frac{7500 \times 0.467 \times 10^{-8}}{7500 \times 20.467 \times 10^{-8}} \times 100 = 2.28\%, \text{ which is negligible}$$

Note In less compressible formations like limestones for which $E_s \approx 2 \times 10^5$ kg/cm², $S = 5 \times 10^{-5}$ and the fractions of this attributable to water and aquifer skeleton are 70% and 30%, respectively.

7.3 DARCY'S LAW

Flow of ground water except through coarse gravels and rockfills is laminar and the velocity of flow is given by Darcy's law (1856), which states that 'the velocity of flow in a porous medium is proportional to the hydraulic gradient', Fig. 7.2, i.e.,

$$V = Ki, \tag{7.4}$$

$$i = \frac{\Delta h}{L} \tag{7.4 a}$$

$$Q = AV = AKi, \quad A = Wb, \quad T = Kb \tag{7.4 b}$$

$$\therefore Q = WbKi \tag{7.4 c}$$

$$\therefore Q = Tiw \tag{7.5}$$

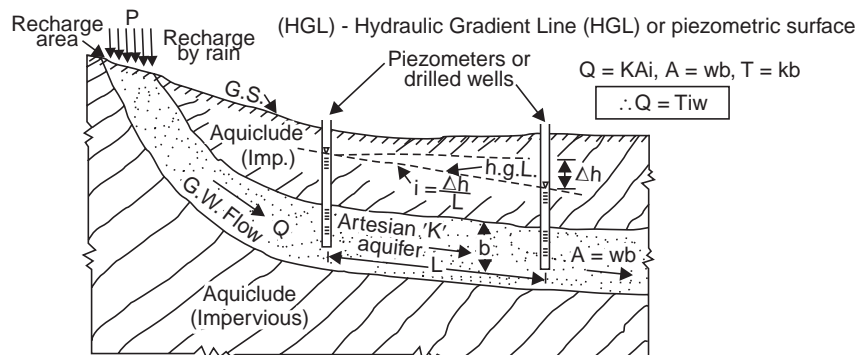

Fig. 7.2 Flow of ground water

where *V* = velocity of flow through the aquifer

K = coefficient of permeability of aquifer soil

i = hydraulic gradient

$$= \frac{\Delta h}{L}, \quad \Delta h = \text{head lost in a length of flow path } L$$

A = cross-sectional area of the aquifer (= wb)

w = width of aquifer

b = thickness of aquifer

T = coefficient of transmissibility of the aquifer

Q = volume rate of flow of ground water (discharge or yield)

Darcy's law is valid for laminar flow, *i.e.*, the Reynolds number (R_e) varies from 1 to 10, though most commonly it is less than 1

$$R_e = \frac{\rho V d}{\mu} \leq 1 \quad \dots(7.6)$$

where ρ = mass density of water

μ = dynamic viscosity of water

d = mean grain size of the aquifer soil

In aquifers containing large diameter solution openings, coarse gravels, rockfills and also in the immediate vicinity of a gravel packed well, flow is no longer laminar due to high gradients and exhibit non linear relationship between the velocity and hydraulic gradient. For example, in a gravel-packed well (mean size of gravel ≈ 5 mm) $R_e \approx 45$ and the flow would be transitional at a distance of about 5 to 10 times the well radius.

7.4 TRANSMISSIBILITY

It can be seen from Eq. (7.5) that $T = Q$, when $i = 1$ and $w = 1$; *i.e.*, the transmissibility is the flow capacity of an aquifer per unit width under unit hydraulic gradient and is equal to the product of permeability times the saturated thickness of the aquifer. In a confined aquifer, $T = Kb$ and is independent of the piezometric surface. In a water table aquifer, $T = KH$, where H is the saturated thickness. As the water table drops, H decreases and the transmissibility is reduced. Thus, the transmissibility of an unconfined aquifer depends upon the depth of GWT.

7.5 WELL HYDRAULICS

Steady radial flow into a well (Dupuit 1863, Thiem 1906)

(a) Water table conditions (unconfined aquifer)

Assuming that the well is pumped at a constant rate Q for a long time and the water levels in the observation wells have stabilised, *i.e.*, equilibrium conditions have been reached, Fig. 7.3 (a).

From Darcy's law, $Q = K i A$

$$Q = K \frac{dy}{dx} (2\pi xy)$$

$$Q \int_{r_1}^{r_2} \frac{dx}{x} = 2\pi K \int_{h_1}^{h_2} y dy$$

$$\therefore Q = \frac{\pi K (h_2^2 - h_1^2)}{2.303 \log_{10} \left(\frac{r_2}{r_1} \right)} \quad \dots(7.7)$$

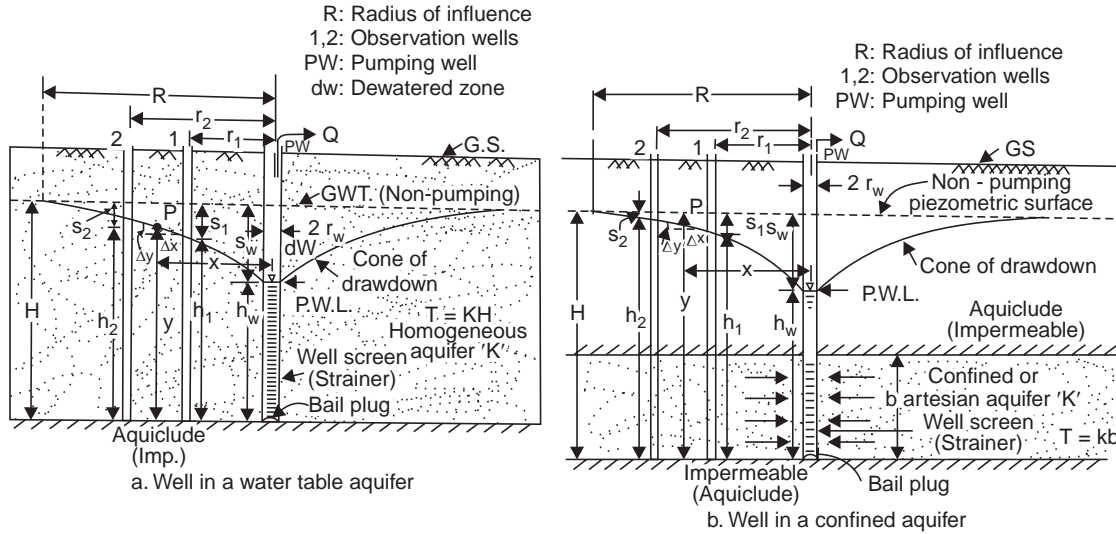

Fig. 7.3 Steady radial flow into a well

Applying the Eq. (7.7) between the face of the well ($r = r_w, h = h_w$) and the point of zero-drawdown ($r = R, h = H$)

$$Q = \frac{\pi K(H^2 - h_w^2)}{2.303 \log_{10} \left(\frac{R}{r_w} \right)} \quad \dots(7.7 a)$$

If the drawdown in the pumped well ($s_w = H - h_w$) is small

$$H^2 - h_w^2 = (H + h_w)(H - h_w), \quad H + h_w \approx 2H$$

$$= 2H(H - h_w)$$

Then,

$$Q = \frac{2\pi KH(H - h_w)}{2.303 \log_{10} \left(\frac{R}{r_w} \right)}, \quad KH = T$$

$$\therefore Q = \frac{2.72 T(H - h_w)}{\log_{10} \left(\frac{R}{r_w} \right)} \quad \dots(7.8)$$

(b) Artesian conditions (confined aquifer)

If the well is pumped at constant pumping rate Q for a long time and the equilibrium conditions have reached, Fig. 7.3 (b).

From Darcy's law, $Q = K i A$

$$Q = K \frac{dy}{dx} (2\pi x b)$$

$$Q \int_{r_1}^{r_2} \frac{dx}{x} = 2\pi K b \int_{h_1}^{h_2} dy$$

$$\therefore Q = \frac{2\pi (kb)(h_2 - h_1)}{2.303 \log_{10} \left(\frac{r_2}{r_1} \right)} \quad \dots(7.9)$$

Applying Eq. (7.9) between the face of the well ($r = r_w$, $h = h_w$) and the point of zero-drawdown ($r = R$, $h = H$), simplifying and putting $T = Kb$,

$$Q = \frac{2.72 T (H - h_w)}{\log_{10} \left(\frac{R}{r_w} \right)} \quad \dots(7.10)$$

which is the same as Eq. (7.8) (for water table conditions under small drawdown).

Note The length of screen provided will be usually half to three-fourth's of the thickness of the aquifer for obtaining a suitable entrance velocity (≈ 2.5 cm/sec) through the slots to avoid incrustation and corrosion at the openings; the percentage open area provided in the screen will be usually 15 to 18%.

Dupuit's Equations Assumptions

The following assumptions are made in the derivation of the Dupuit Thiem equations:

- (i) Stabilised drawdown—*i.e.*, the pumping has been continued for a sufficiently long time at a constant rate, so that the equilibrium stage of steady flow conditions have been reached.
- (ii) The aquifer is homogeneous, isotropic, of infinite areal extent and of constant thickness, *i.e.*, constant permeability.
- (iii) Complete penetration of the well (with complete screening of the aquifer thickness) with 100% well efficiency.
- (iv) Flow lines are radial and horizontal and the flow is laminar, *i.e.*, Darcy's law is applicable.
- (v) The well is infinitely small with negligible storage and all the pumped water comes from the aquifer.

The above assumptions may not be true under actual field conditions; for example, if there is no natural source of recharge nearby into the aquifer, all the pumped water comes from storage in the aquifer resulting in increased drawdowns in the well with prolonged pumping and thus the flow becomes unsteady (transient flow conditions). There may be even leakage through the overlying confining layer (say, from a water table aquifer above the confining layer) of an artesian aquifer (leaky artesian aquifer). The hydraulics of wells with steady and unsteady flow under such conditions as developed from time to time by various investigators like Theis, Jacob, Chow, De Glee, Hantush, Walton, Boulton etc. have been dealt in detail in the author's companion volume 'Ground Water' published by M/s Wiley Eastern Limited New Delhi and the reader is advised to refer the book for a detailed practical study of Ground Water dealing with Hydrogeology, Ground Water Survey and Pumping Tests, Rural Water Supply and Irrigation Systems. For example, in the Theis equation for unsteady radial flow into a well it is assumed that the water pumped out is immediately released from storage of the aquifer (no recharge) as the piezometric surface or the water table drops. But in unconfined aquifers and leaky artesian aquifers (that receive water from upper confining layer with a free water table), the rate of fall of the water table may be faster than the rate at which pore water is released; this is called 'delayed yield' as suggested by Boulton.

7.6 SPECIFIC CAPACITY

The specific capacity $\frac{Q}{S_w}$ of a well is the discharge per unit drawdown in the well and is usually expressed as lpm/m. The specific capacity is a measure of the effectiveness of the well; it decreases with the increase in the pumping rate (Q) and prolonged pumping (time, t).

In Eq. (7.8) by putting $r_w = 15$ cm, $R = 300$ m, $H - h_w = S_w$, the specific capacity

$$\frac{Q}{S_w} \approx \frac{T}{1.2}, \text{ in consistent units} \quad \dots(7.11)$$

Example 7.3 A 20-cm well penetrates 30 m below static water level (GWT). After a long period of pumping at a rate of 1800 lpm, the drawdowns in the observation wells at 12 m and 36 m from the pumped well are 1.2 m and 0.5 m, respectively.

Determine: (i) the transmissibility of the aquifer.

(ii) the drawdown in the pumped well assuming $R = 300$ m.

(iii) the specific capacity of the well.

Solution Dupuit's Eq. (7.7): $Q = \frac{\pi K(h_2^2 - h_1^2)}{2.303 \log_{10} r_2/r_1}$

$$h_2 = H - s_2 = 30 - 0.5 = 29.5 \text{ m}; h_1 = H - s_1 = 30 - 1.2 = 28.8 \text{ m}$$

$$\frac{1.800}{60} = \frac{\pi K(29.5^2 - 28.8^2)}{2.303 \log_{10} 36/12}$$

$$\therefore K = 2.62 \times 10^{-4} \text{ m/sec} \quad \text{or} \quad \mathbf{22.7 \text{ m/day}}$$

(i) Transmissibility $T = KH = (2.62 \times 10^{-4}) 30 = 78.6 \times 10^{-4} \text{ m}^2/\text{sec}$,

or $= 22.7 \times 30 = \mathbf{681 \text{ m}^2/\text{day}}$

(ii) Eq. (7.8): $Q = \frac{2.72 T (H - h_w)}{\log_{10} R/r_w}$

$$\frac{1.800}{60} \equiv \frac{2.72(78.6 \times 10^{-4}) S_w}{\log_{10} 300/0.10}$$

\therefore drawdown in the well, $S_w = \mathbf{4.88 \text{ m}}$

(iii) The specific capacity of the well

$$= \frac{Q}{S_w} = \frac{1.800}{60 \times 4.88} = 0.0062 \text{ (m}^3 \text{ sec}^{-1}/\text{m)}$$

or $\mathbf{372 \text{ lpm/m}}$

$$\frac{Q}{S_w} \approx \frac{T}{1.2} = \frac{78.6 \times 10^{-4}}{1.2} = 0.00655 \text{ (m}^2 \text{ sec}^{-1}/\text{m)}$$

or $\mathbf{393 \text{ lpm/m}}$

Example 7.4 A tube well taps an artesian aquifer. Find its yield in litres per hour for a drawdown of 3 m when the diameter of the well is 20 cm and the thickness of the aquifer is 30 m. Assume the coefficient of permeability to be 35 m/day.

If the diameter of the well is doubled find the percentage increase in the yield, the other conditions remaining the same. Assume the radius of influence as 300 m in both cases.

Solution Dupuit's Eq. (7.10): $Q = \frac{2.72 T (H - h_w)}{\log_{10} R/r_w}$

$$= \frac{2.72 \{(35/24) \times 30\}3}{\log_{10} (300/0.10)} = 102.7 \text{ m}^3/\text{hr}$$

or

$$= \mathbf{102700 \text{ lph}}$$

The yield $Q \propto \frac{1}{\log (R/r_w)}$... (7.12)

other things remaining same.

If the yield is Q' after doubling the diameter, *i.e.*,

$$r_w' = 0.10 \times 2 = 0.20 \text{ m}$$

$$\frac{Q}{Q'} = \frac{\log R/r_w}{\log R/r_w'}$$

$$\log \frac{300}{0.10} = 3.4771, \quad \log \frac{300}{0.20} = 3.1761$$

$$\frac{102.7}{Q'} = \frac{3.1761}{3.4771} \quad \therefore Q' = 112.4 \text{ m}^3/\text{hr}$$

percentage increase in yield = $\frac{Q' - Q}{Q} \times 100 = \frac{112.4 - 102.7}{102.4} \times 100 = \mathbf{9.45\%}$

Thus, by doubling the diameter the percentage in yield is only about 10%, which is uneconomical. Large diameter wells necessarily do not mean proportionately large yields. The diameter of a tube well usually ranges from 20 to 30 cm so that the bowl assembly of a deep well or a submersible pump can easily go inside with a minimum clearance.

Refer Appendix-D for Unsteady Groundwater Flow.

7.7 CAVITY WELLS

If a relatively thin impervious formation or a stiff clay layer is encountered at a shallow depth underlain by a thick alluvial stratum, then it is an excellent location for a cavity well. A hole is drilled using the hand boring set and casing pipe is lowered to rest firmly on the stiff clay layer, Fig. 7.4. A hole of small cross-section area is drilled into the sand formation and is developed into a big hollow cavity by pumping at a high rate or by operating a plunger giving a large yield. The depth of the cavity at the centre varies from 15-30 cm with 6-8 m radius of the cavity. The flow of water into the cavity is spherical and the yield is low. The failure of a cavity well is usually due to caving of the clay roof. Since the depth is usually small, deep well pumps are not necessary and thus the capital costs of construction, development and installation of pumpset of a cavity well are low.

Yield of Cavity Well

For the unsteady flow condition, the pumping rate Q of a cavity well is given by

$$s = \frac{Q\sqrt{S_s}}{6K\sqrt{\pi t}} + \frac{Q}{2\pi kr} \quad \dots(7.13)$$

where s = drawdown in the observation well at a distance r from the cavity well

Q = constant pumping rate

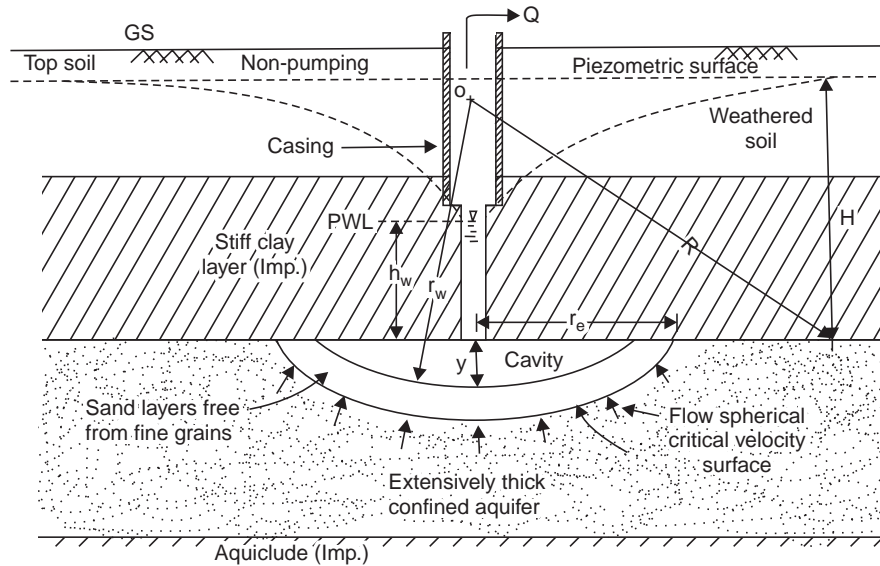

Fig. 7.4 Flow into a cavity well

S_s = specific storage coefficient (*i.e.*, for unit aquifer thickness)

K = permeability of the aquifer

t = time since pumping began

For steady state flow condition, the well yield is given by

$$Q = \frac{2\pi Ky (H - h_w)}{1 - r_w / R} \quad \dots(7.14)$$

and the width of the cavity, Fig. 7.4

$$r_e = \sqrt{(2r_w - y)y} \quad \dots(7.15)$$

where y = depth of cavity (at the centre)

r_w = radius of cavity

R = radius of influence

Example 7.5 The following data are obtained from a cavity tube well:

| | |
|-----------------------------|----------|
| Discharge | 30 lps |
| Drawdown | 4 m |
| Permeability of the aquifer | 50 m/day |
| Depth of cavity | 20 cm |
| Radius of influence | 150 m |

Determine the radius and width of cavity.

Solution Well yield $Q = \frac{2\pi Ky (H - h_w)}{1 - \frac{r_w}{R}}$

$$\frac{30}{1000} = 2\pi \times \frac{50}{24 \times 60 \times 60} \times \frac{0.20 \times 4}{1 - \frac{r_w}{150}}$$

$$\begin{aligned} \therefore \text{Radius of cavity, } r_w &= \mathbf{135.5 \text{ m}} \\ \text{Width of cavity, } r_e &= \sqrt{(2r_w - y)y} = \sqrt{(2 \times 4.5 - 0.2) 0.2} = \mathbf{7.36 \text{ m}} \end{aligned}$$

7.8 HYDRAULICS OF OPEN WELLS

This equation does not apply for shallow dug open wells since there is no instantaneous release of water from the aquifer, most of the water being pumped only from storage inside the well (Fig. 7.5).

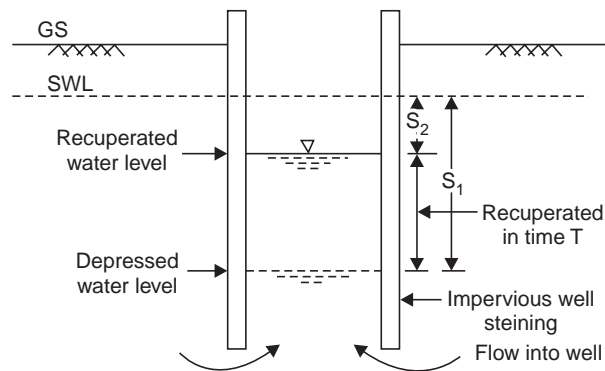

Fig. 7.5 Recuperation test in open wells

In alluvial soil, if the water is pumped at a high rate the depression head (static water level–water level inside the well during pumping) will increase, which may cause excess gradients resulting in loosening of sand particles (quick sand phenomenon). This limiting head is called ‘critical depression head’. The ‘safe working depression head’ is usually one-third of the critical head and the yield under this head is called the *maximum safe yield* of the well.

Yield Tests

The following tests may be performed to get an idea of the probable yield of the well:

- (a) Pumping test
- (b) Recuperation test

(a) *Pumping Test*. In the pumping test, the water level in the well is depressed to an amount equal to the safe working head for the sub-soil. Then the water level is kept constant by making the pumping rate equal to the percolation into the well. The quantity of water pumped in a known time gives an idea of the probable yield of the well of the given diameter. The test may be carried out in an existing open well.

In hard-rock areas,

if D = diameter of the well

d = depth of water column

Q = pumping rate

t = time required for emptying the well

then,

Rate of seepage into the well

$$\begin{aligned}
 &= \frac{\text{Volume of water pumped out} - \text{Volume of water stored in the well}}{\text{Time of pumping}} \\
 &= \frac{Qt - \frac{\pi D^2}{4} \times d}{t} \quad \dots(7.16)
 \end{aligned}$$

(b) *Recuperation Test.* In the recuperation test, the water level in the well is depressed by an amount less than the safe working head for the subsoil. The pumping is stopped and the water level is allowed to rise or recuperate. The depth of recuperation in a known time is noted from which the yield of the well may be calculated as follows (Fig. 7.5).

Let the water level inside the well rise from s_1 to s_2 (measured below static water level, *swl*) in time T . If s is the head at any time t , from Darcy's law

$$Q = KAi$$

if a head s is lost in a length L of seepage path

$$Q = KA \frac{s}{L}$$

$$Q = CAs$$

where the constant $C = \frac{K}{L}$ and has dimensions of T^{-1} .

If in a time dt , the water level rises by an amount ds

$$Q dt = -A ds$$

the -ve sign indicates that the head decreases as the time increases.

Putting $Q = CAs$

$$CAs dt = -A ds$$

$$C \int_0^T dt = \int_{s_1}^{s_2} -\frac{ds}{s}$$

$$\therefore C = \frac{2.303}{T} \log_{10} \frac{s_1}{s_2} \quad \dots(7.17)$$

Assuming the flow is entirely from the bottom (impervious steining of masonry), the yield of the well

$$Q = CAH \quad \dots(7.17a)$$

where Q = safe yield of the well

A = area of cross section of the well

H = safe working depression head

C = specific yield of the soil

From Eq. (7.17a) $Q = C$ when $A = 1$, $H = 1$, *i.e.*, the specific yield of the soil is the discharge per unit area under a unit depression head and has dimension of T^{-1} (1/time) and the usual values are

$$C = 0.25 \text{ hr}^{-1} \text{ for clayey soil}$$

$$C = 0.50 \text{ hr}^{-1} \text{ for fine sand}$$

$$C = 1.00 \text{ hr}^{-1} \text{ for coarse sand}$$

The value of C is usually determined from a recuperation test, (Eq. (7.17)).

Example 7.6 A well of size 7.70×4.65 m and depth 6.15 m in lateritic soil has its normal water level 5.08 m below ground level (bgl). By pumping for $1\frac{1}{2}$ hours, the water level was

depressed to 5.93 m bgl and the pumping was stopped. The recuperation rates of the well during 4 hours after the pumping stopped are given below. The total volume of water pumped during $1\frac{1}{2}$ hours of pumping was 32.22 m^3 . (no well steining is provided)

Recuperation rates

| <i>Time since pumping stopped (min)</i> | <i>Water level bgl (m)</i> |
|---|--------------------------------|
| 0 | 5.930 |
| 15 | 5.890 |
| 30 | 5.875 |
| 45 | 5.855 |
| 60 | 5.840 |
| 90 | 5.820 |
| 120 | 5.780 |
| 180 | 5.715 |
| 240 | 5.680 |

Determine

- (i) Rate of seepage into the well during pumping.
- (ii) Specific yield of the soil and specific capacity of the well.
- (iii) Yield of the well under a safe working depression head of 0.85 m.
- (iv) The area of crop that can be irrigated under the well (assume a peak consumptive use of 4 mm and irrigation efficiency of 75%).
- (v) Diameter of the well in such a soil to get an yield of 3000 lph under a safe working depression head of 0.8 m.

Solution (i) Seepage into the well—from pumping data:

$$\text{Volume of water pumped out} = 32.22 \text{ m}^3$$

$$\begin{aligned} \text{Volume of water stored in the well (that was pumped out)} \\ = (7.70 \times 4.65) (5.93 - 5.08) = 30.5 \text{ m}^3 \end{aligned}$$

Rate of seepage into the well

$$= \frac{32.22 - 30.5}{1.5} = 1.15 \text{ m}^3/\text{hr}$$

(ii) Specific yield of the soil

$$\begin{aligned} C &= \frac{2.303}{T} \log_{10} \frac{s_1}{s_2} = \frac{2.303}{4} \log_{10} \frac{5.93 - 5.08}{5.68 - 5.08} \\ &= 0.09 \text{ hr}^{-1} \text{ (or } \text{m}^3/\text{hr per m drawdown)} \end{aligned}$$

Specific capacity of the well is its yield per unit drawdown

$$Q = CAH$$

$$\begin{aligned} \therefore \text{ Specific capacity} &= Q/H = CA = 0.09 (7.70 \times 4.65) \\ &= \mathbf{3.58 \text{ m}^3 \text{ hr}^{-1}/\text{m}} \text{ (or m}^2/\text{hr)} \end{aligned}$$

(iii) Safe yield of the well

$$Q = CAH = 0.09 (7.70 \times 4.65) 0.85 = 3.04 \text{ m}^3/\text{hr}$$

which is more than twice the seepage into the well during pumping.

(iv) Area of crop that can be irrigated under the well:

Data to draw the curve s_1/s_2 vs. t (s_1 = total drawdown, s_2 = residual drawdown): $SWL = 5.08 \text{ m}$, $s_1 = 5.93 - 5.08 = 0.85 \text{ m}$

| Time since pumping stopped t (min) | Water level bgl (m) | Residual drawdown $s_2 = wL - SWL$ (m) | Ratio (s_1/s_2) |
|--|---------------------------|--|---------------------|
| 0 | 5.930 | 0.850 (= s_1) | 1.00 |
| 15 | 5.890 | 0.810 | 1.05 |
| 30 | 5.875 | 0.795 | 1.07 |
| 45 | 5.855 | 0.775 | 1.09 |
| 60 | 5.840 | 0.760 | 1.11 |
| 90 | 5.820 | 0.740 | 1.15 |
| 120 | 5.780 | 0.700 | 1.21 |
| 180 | 5.715 | 0.635 | 1.33 |
| 240 | 5.680 | 0.600 | 1.41 |

From the plot of ' s_1/s_2 vs. time' on a semi-log paper (Fig. 7.6), it is seen that $s_1/s_2 = 9.5$ after 24 hours of recovery (by extending the straight line plot), and the residual drawdown

after 24 hours, $s_{24} = \frac{0.85}{9.5} \approx 0.09 \text{ m}$; hence the depth of recuperation per day = $0.85 - 0.09 = 0.76$

m and the volume of water available per day $\approx (7.70 \times 4.65) \approx 27.2 \text{ m}^3$. With an average peak consumptive use of 4 mm for the type of crops grown and irrigation efficiency of 75%, the area of crop (A_{crop}) that can be irrigated under one well in lateritic soils is

$$\frac{4}{1000 \times 0.75} \times A_{\text{crop}} = 27.2$$

$$\therefore A_{\text{crop}} = 5100 \text{ m}^2 \text{ or } \mathbf{0.5 \text{ ha}}$$

(v) Diameter of the well to yield 3000 lph:

$$Q = CAH$$

$$\frac{3000}{1000} = 0.09 \times \pi \times \frac{D^2}{4} \times 0.8$$

$$\therefore D = 7.3 \text{ m, which is too big}$$

It may be noted that it is not advisable to go deeper in these areas otherwise salt water intrusion takes place.

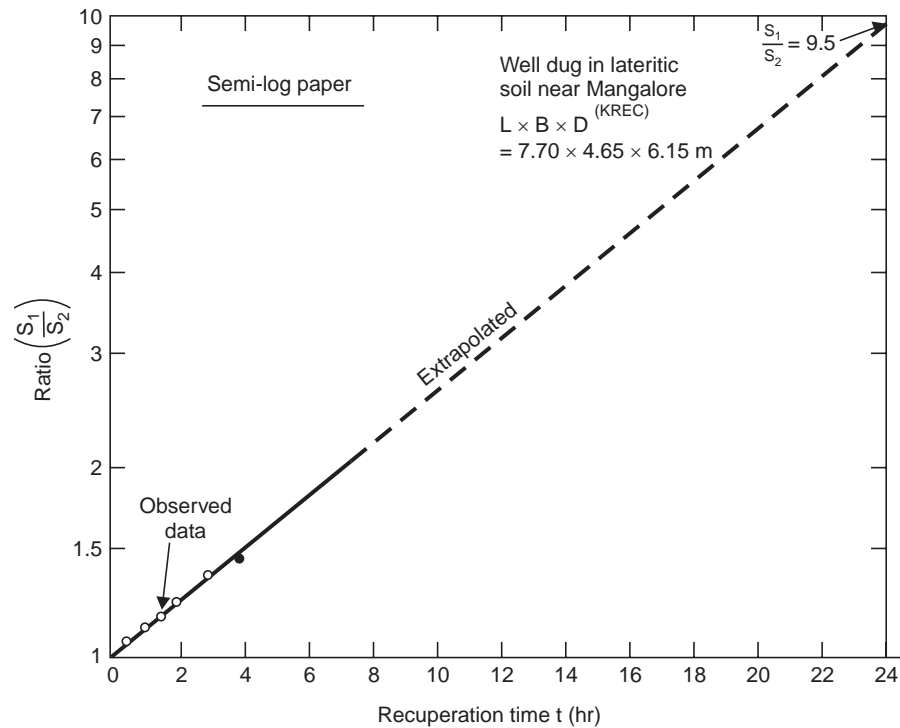

Fig. 7.6 Plot of recuperation test data (Example 7.6)

7.9 CONSTRUCTION OF OPEN WELLS

In alluvial soil, where an impervious vertical steining is provided to support the soil, percolation into the well is entirely from the bottom and depends on the area of cross-section of the well. Bigger diameter wells are recommended in such soil to give larger yields. In case of wells in rocky substrata with fissures and cracks, the lower portion of the steining may be provided with alternate bands of masonry laid dry (*i.e.*, without cement mortar) (Fig. 7.7), and the percolation into the well is mostly from the sides through fissures and cracks in the weathered rock. In such wells, higher yields are obtained by going deeper, as long as the weathering and fractures are evident rather than making the wells wider or larger diameter. Larger diameter wells also involve large volume of excavation in rocks and the mounds of excavated rock deposited on the ground surface occupy considerable area of cultivable land. Sometimes, it is proposed to widen when it is felt that such widening will, include some well-defined fissures and fractures.

Some of the existing wells may be revitalised by deepening by blasting; vertical bores may be drilled at the bottom of the well when it is felt it will tap some layer under pressure, *i.e.*, a dug-cum-borewell (Fig. 7.8), with a centrifugal pump kept at the bottom of the open well and the suction pipe lowered inside the bore, thus reducing the suction lift and saving the costs involved in deep well turbine pump or submersible pump installations in drilled deep wells from the ground surface. Lateral bores horizontal or inclined, may be drilled in the direction of certain well-defined fractures yielding water.

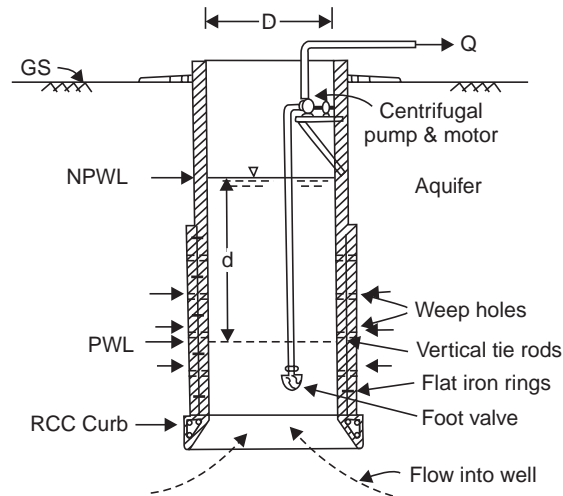

Fig. 7.7 Open well construction

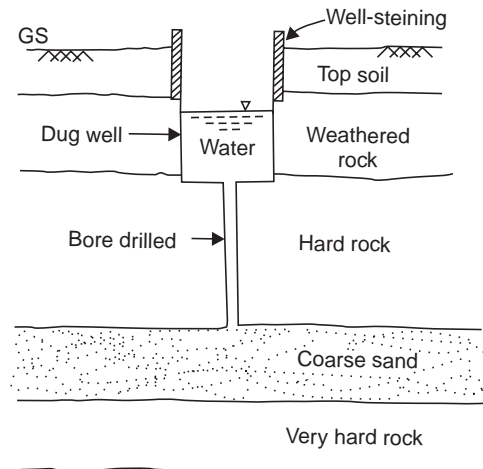

Fig. 7.8 Dug-cum-borewell

7.10 SPACING OF WELLS

Pumping wells should be spaced far apart so that their cones of depression will not overlap over each other resulting in the reduction of their yields and/or increased drawdowns (Fig.7.9), *i.e.*, to avoid 'well interference', the wells should be spaced beyond their radii of influence. This is roughly estimated to be around 600–1000 m in alluvial area and around 100–200 m in hard rock areas.

An open dug well should be located beyond the cone of depression of the tubewell; otherwise when the tubewell is pumping, it will dewater the open well. The open well can get water only when the tubewell pumping is stopped and fast recuperation takes place.

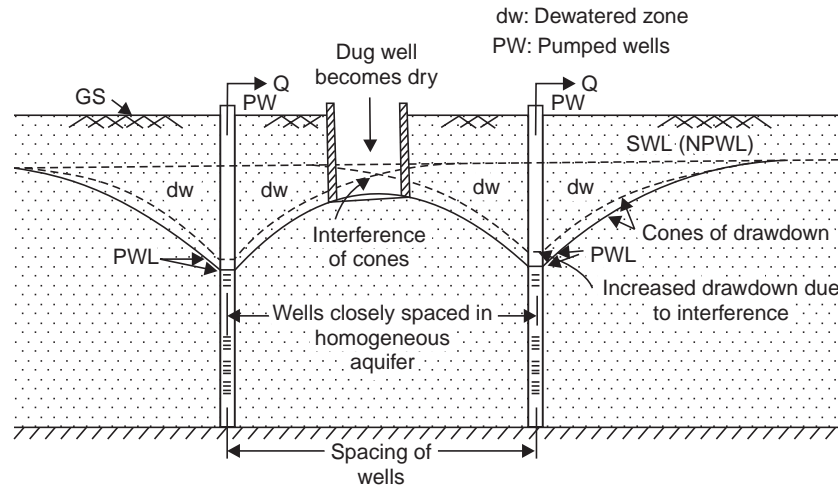

Fig. 7.9 Well interference

QUIZ VII

I Choose the correct statement/s in the following:

1 The underground formations, which serve as good aquifers are in the order:

- (i) consolidated formations of clays and shales
- (ii) rock with no signs of weathering or fractures
- (iii) rock with fissures and cracks
- (iv) cavernous lime stones
- (v) sand stones
- (vi) vesicular basalts
- (vii) unconsolidated gravels, sands and alluvium

2 The soil properties characteristic of good water yield are:

- (i) porosity
 - (ii) permeability
 - (iii) specific yield
 - (iv) storage coefficient
 - (v) transmissibility
 - (vi) uniformity coefficient > 3
 - (vii) uniformity coefficient < 2
 - (viii) effective size > 0.1 mm
 - (ix) Reynolds number > 10
 - (x) specific capacity of the well > 30 lpm/m
 - (xi) all the above characteristics
- (1-except i, ii, 2 ii, iii, iv, v, viii, x)

II Match the items in 'A' with the items in 'B':

A

- (i) Ground water flow
- (ii) Unconsolidated alluvium
- (iii) Aquiclude
- (iv) Specific yield (S_y)
- (v) Confined aquifer
- (vi) Storage coefficient
- (vii) Transmissibility (T)

B

- (a) Recuperation test
- (b) Bore at the bottom of open well
- (c) Lateral or vertical bores
- (d) Well spacing
- (e) $n - S_r$
- (f) Artesian
- (g) $f(K_w, E_s)$

- | | |
|--|--|
| (viii) Rate of ground water flow (Q) | (h) KH or Kb |
| (ix) Reynolds number (R_e) | (i) $T iW$ |
| (x) Dupuit's equation | (j) $\rho v d/\mu$ |
| (xi) Specific capacity | (k) $\frac{Q}{sw} \approx \frac{T}{1.2}$ |
| (xii) Open well | (l) Stabilised drawdown |
| (xiii) Well revitalisation | (m) Clay |
| (xiv) Dug-cum-borewell | (n) Aquifer |
| (xv) Well interference | (o) Darcy's law |

III Say 'true' or 'false'; if false, give the correct statement:

- (i) The transmissibility of a confined aquifer depends upon the depth of the water table while that of the water table aquifer does not.
- (ii) The available yield of a tube well can be doubled by doubling the diameter.
- (iii) The specific yield of an aquifer may be more than its porosity.
- (iv) Storage coefficient is the same as specific yield for a water table aquifer.
- (v) Flow in a medium sand aquifer is entirely laminar.
- (vi) Plants usually extract water from the capillary zone (the intermediate belt or vadose zone).

(false: *i, ii, iii*)

QUESTIONS

- 1 (a) Define 'transmissibility' and 'storage coefficient' of an aquifer.
 (b) Calculate the discharge from a tubewell of 20-cm diameter penetrating fully into a confined aquifer of 20-m thick and having a permeability of 40 m/day. The drawdown in the well is 3 m and zero drawdown at 300 m from the well.
 If the diameter of the well is doubled, find the percentage increase in the yield, the other conditions remaining the same.
 State the assumptions in the formula you use. (1303.7 lpm)
- 2 A tubewell penetrates fully an unconfined aquifer. Calculate the discharge from the well in lpm from the following data:

| | |
|---|----------|
| Diameter of the well | 30 cm |
| Drawdown in the well | 3 m |
| Effective length of the strainer under the above drawdown | 10 m |
| Coefficient of permeability of the aquifer | 40 m/day |
| Radius of zero drawdown | 300 m |
- 3 A 20-cm well penetrates 25 m below the static water table. After 24 hours of pumping out at the rate of 800 lpm, the water level in a test well at 80 m from the pumping well is lowered by 0.53 m and in a test well 20 m away 2.11 m. Find the coefficient of transmissibility of the aquifer.
- 4 (a) What is the nature of ground water flow? State the law governing the flow with limitations, if any.

- (b) In an area of 100 ha, the water table dropped by 4.5 m due to continuous ground water pumping. If the porosity of the aquifer soil is 26% and the specific retention is 10 per cent, determine:
- the specific yield of the aquifer.
 - the decrease in the ground water storage. (16%, 72 ham)
- 5 In a certain alluvial basin of 120 km², 100 Mm³ of ground water was pumped in a year and the ground water table dropped by 5 m during the year. Assuming no replenishment, estimate the specific yield of the aquifer. If the specific retention is 12%, what is the porosity of the soil? (16.7%, 28.7%)
- 6 An artesian aquifer 25-m thick has a porosity of 17% and bulk modulus of compression 2400 kg/cm². Estimate the storage coefficient of the aquifer. What fraction of this is attributable to the expansibility of water ?
Bulk modulus of elasticity of water = 2.14×10^4 kg/cm². (0.00106, 1.87%)
- 7 A well penetrates into an unconfined aquifer having a saturated depth of 50 m. The discharge is 250 lpm at 8 m drawdown. What would be the discharge at 10 m drawdown. The radius of influence in both the cases may be taken as same.
- 8 (a) Explain: 'the water balance of a catchment'.
(b) In a given year over 60 km² catchment, 120 cm of rainfall was received and 1000 ha-m was discharged through the outlet. The ground water table rose by 30 cm and the average specific yield of the soil was 18%. The soil moisture increased by 5 cm on an average. Estimate the evapotranspiration during the year. (93 cm)
- 9 (a) Describe the method of construction of open wells
(i) in a soil where a clayey stratum is encountered.
(ii) in rocky sub-strata.
(b) A well of size 6.60 × 4.05 m and depth 4.7 m in the lateritic soil near Mangalore (west coast of India) has its normal water level at 3.825 m below ground level (bgl). By pumping for 1½ hours, the water level (bgl) was depressed to 4.525 m and the pumping was stopped. The recuperation rates of the well during 2½ hours after the pumping stopped are given below.
The total volume of water pumped during 1½ hours of pumping was 28.87 m³ (no well steining is provided)

| <i>Recuperation rates</i> | |
|---|-----------------------------|
| <i>Time since pumping stopped (min)</i> | <i>Water level, bgl (m)</i> |
| 0 | 4.525 |
| 10 | 4.365 |
| 20 | 4.245 |
| 30 | 4.135 |
| 40 | 4.075 |
| 50 | 4.015 |
| 60 | 3.985 |
| 70 | 3.960 |
| 80 | 3.950 |
| 90 | 3.935 |
| 120 | 3.920 |
| 150 | 3.902 |

- Determine
- (i) Rate of seepage into the well during pumping
 - (ii) Specific yield of the soil and specific capacity of the well
 - (iii) Yield of the well under a safe working depression head of 0.7 m
 - (iv) The area of crop that can be irrigated under the well, assuming a peak consumptive use of 4 mm and irrigation efficiency of 75%.
 - (v) Diameter of the well in such a soil to get an yield of 3000 lph under a safe working depression head of 0.7 m (note that it is not advisable to go deeper in these areas lest salt water intrusion may not take place).
- 10** In a recuperation test, the static water level in an open well was depressed by pumping by 3 m and it recuperated 1.5 m in 1 hour. If the diameter of the well is 3 m and the safe working depression head is 2.4 m, find the average yield of the well in lpm. What area of crop can come under this well assuming a peak consumptive use of 5 mm and irrigation efficiency of 75%?
- 11** Determine the diameter of an open well in coarse sand to give an average yield of 200 lpm under a safe working depression head of 2.5 m (Hint: for coarse sand $C \approx 1 \text{ hr}^{-1}$).
- 12** Distinguish between:
- (i) Specific capacity of a well and specific yield of an aquifer
 - (ii) Aquifer and aquiclude
 - (iii) Open wells and tube wells
 - (iv) Water table and artesian aquifers
 - (v) Drainage divide and ground water divide
- 13** Write short notes on:
- (i) Well development
 - (ii) Well spacing
 - (iii) Radius of influence
 - (iv) Validity of Darcy's law
 - (v) Dug-cum-borewell
 - (vi) Well revitalisation
 - (vii) Well interference
 - (viii) Recuperation test for open well

Chapter 8

FLOODS-ESTIMATION AND CONTROL

8.1 SIZE OF FLOODS

A flood is an unusual high stage of a river due to runoff from rainfall and/or melting of snow in quantities too great to be confined in the normal water surface elevations of the river or stream, as the result of unusual meteorological combination.

The maximum flood that any structure can safely pass is called the 'design flood' and is selected after consideration of economic and hydrologic factors. The design flood is related to the project feature; for example, the spillway design flood may be much higher than the flood control reservoir design flood or the design flood adopted for the temporary coffer dams. A design flood may be arrived by considering the cost of constructing the structure to provide flood control and the flood control benefits arising directly by prevention of damage to structures downstream, disruption communication, loss of life and property, damage to crops and under-utilisation of land and indirectly, the money saved under insurance and workmen's compensation laws, higher yields from intensive cultivation of protected lands and elimination of losses arising from interruption of business, reduction in diseases resulting from *inundation* of flood waters. The direct benefits are called *tangible benefits* and the indirect benefits are called *intangible benefits*. The design flood is usually selected after making a cost-benefit analysis and exercising engineering judgement.

When the structure is designed for a flood less than the maximum probable, there exists a certain amount of flood risk to the structure, nor is it economical to design for 100% flood protection. Protection against the highest rare floods is uneconomical because of the large investment and infrequent flood occurrence.

In the design flood estimates, reference is usually made to three classes:

(a) *Standard Project Flood (SPF)*. This is the estimate of the flood likely to occur from the most severe combination of the meteorological and hydrological conditions, which are reasonably characteristic of the drainage basin being considered, but excluding extremely rare combination.

(b) *Maximum Probable Flood (MPF)*. This differs from the SPF in that it includes the extremely rare and catastrophic floods and is usually confined to spillway design of very high dams. The SPF is usually around 80% of the MPF for the basin.

(c) *Probable Maximum Precipitation (PMP)*. From the observations of air moisture from the maximum dew-point and temperature recorded and air-inflow (from the wind speed and barometric pressure recorded), the moisture inflow index in the storm is determined. The best known upward adjustment to be applied to the historical and hypothetical major storms is the

maximisation with respect to moisture charge. The adjusted storm rainfall is assumed to bear the same ratio to the observed storm rainfall, as the maximum moisture charge over the basin to the moisture charge of the observed storm. From the critical combinations of storms, and moisture adjustment the PMP is derived which, after minimising losses, when applied on the design unit hydrograph for the basin, will produce the MPF. Occasionally when enough storm data for the given basin is not available, PMP can be estimated by adopting a severe storm over neighbouring catchment (which is meteorologically homogeneous) and transposing it to the catchment under consideration.

(d) *Design Flood*—It is the flood adopted for the design of hydraulic structures like spillways, bridge openings, flood banks, etc. It may be the MPF or SPF or a flood of any desired recurrence interval depending upon the degree of flood protection to be offered and cost economics of construction of structures to the desired flood stage; the design flood is usually selected after making a cost-benefit analysis, *i.e.*, the ratio of benefit to cost may be desired to be the maximum.

8.2 ESTIMATION OF PEAK FLOOD

The maximum flood discharge (peak flood) in a river may be determined by the following methods:

- (i) Physical indications of past floods—flood marks and local enquiry
- (ii) Empirical formulae and curves
- (iii) Concentration time method
- (iv) Overland flow hydrograph
- (v) Rational method
- (vi) Unit hydrograph
- (vii) Flood frequency studies

The above methods are discussed below:

(i) *Observations at nearby structure.* By noting the flood marks (and by local enquiry), depths, affluxes (heading up of water near bridge openings, or similar obstructions to flow) and other items actually at an existing bridge, on anecut (weir) in the vicinity, the maximum flood discharge may be estimated. The flood marks are connected by levelling, the profile is plotted and HFL marked on it, and the cross sectional area is determined. The surface fall at HFL is calculated from the difference in HFL at known distance apart. It may be checked with the bed slope; there should not be much disparity between the two. By assuming a suitable value of Manning's n for the nature (roughness) of bed and sides of the river, the velocity may be determined by Manning's or Chezy's formula and the flood discharge estimated, see example 6.4.

(ii) *Empirical Flood Formulae*

1. Dickens formula for moderate size basins of north and central India

$$Q = CA^{3/4} \quad \dots(8.1)$$

the coefficient $C = 11-14$, where the *aar* is 60–120 cm

= 14–19 in Madhya Pradesh

= 32 in western Ghats

up to 35, maximum value

2. Ryves formula derived from a study of rivers in south India

$$A = CA^{2/3} \quad \dots(8.2)$$

Coefficient $C = 6.8$ within 80 km of coast
 $= 8.3$ for areas between 80 and 2400 km from the coast
 $= 10.0$ for limited area near the hills
 up to 40, actual observed values

3. Inglis formula for fan-shaped catchments of Bombay state (Maharashtra)

$$Q = \frac{124A}{\sqrt{A + 10.4}} \quad \dots(8.3)$$

4. Myers formula $Q = 175 \sqrt{A}$... (8.4)

5. Ali Nawab Jang Bahadur formula for the old Hyderabad state

$$Q = CA^{(0.993 - 1/14 \log A)} \quad \dots(8.5)$$

the coefficient C varies from 48 to 60

Maximum value of $C = 85$

6. Fuller's formula (1914)

$$Q = CA^{0.8} (1 + 0.8 \log T_r)(1 + 2.67 A^{-0.3}) \quad \dots(8.6)$$

constants derived from the basins in USA 10 years data is required for sufficient reliability. The coefficient C varies from 0.026 to 2.77; T = recurrence interval in years. Fuller was the first to suggest that frequency should be considered as a factor in estimating floods.

7. Greager's formula for USA

$$Q = C(0.386 A)^{0.894(0.386 A)^{-0.048}} \quad \dots(8.7)$$

the coefficient $C \approx 130$ (140.5 for areas most favourable to large floods)

8. Burkli Ziegler formula for USA

$$Q = 412 A^{3/4} \quad \dots(8.8)$$

In all the above formula, Q is the peak flood in cumec and A is the area of the drainage basin in km^2 .

(iii) *Envelope Curves*. Areas having similar topographical features and climatic conditions are grouped together. All available data regarding discharges and flood formulae are compiled along with their respective catchment areas. Peak flood discharges are then plotted against the drainage areas and a curve is drawn to cover or envelope the highest plotted points. Envelope curves are generally used for comparison only and the design floods got by other methods, should be higher than those obtained from envelope curves. For Indian rivers, enveloping curves from observed floods have been developed by Kanwar Sain and Karpov, Fig. 8.1 (a).

(iv) *Concentration Time Method*. The concentration time method of estimating the peak discharge consists of two steps:

(i) Determination of the concentration time, etc.

(ii) Selection of the period of maximum net rainfall for the concentration time duration. This method can be used for design storms or in conjunction with intensity-duration-frequency curves.

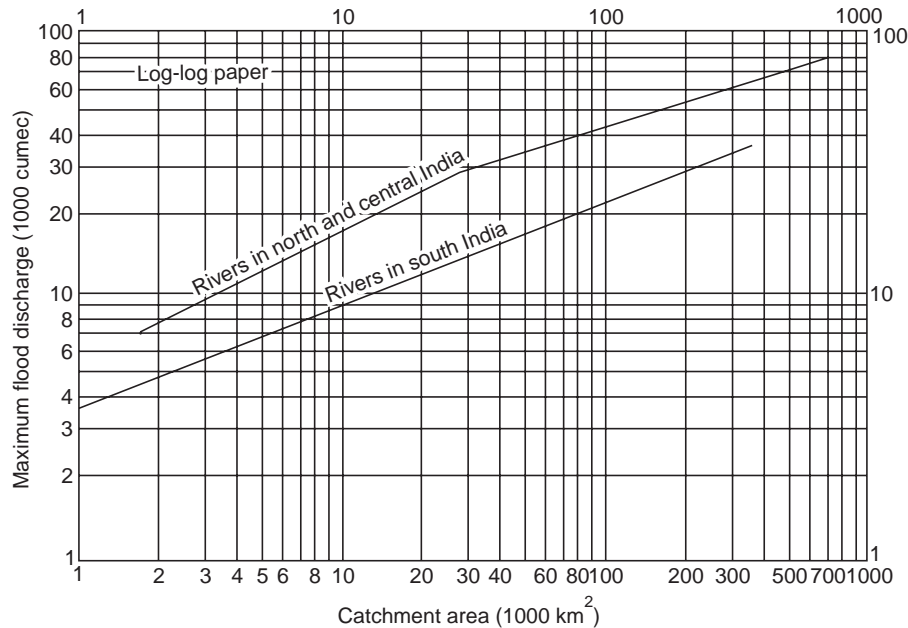

Fig. 8.1(a) Enveloping curves of Kanwar Sain and Karpov

Example 8.1 Determine the peak discharge at the concentration point for a basin of 80 hectares having a time of concentration of 30 minutes due to a 5-cm flash storm, if the duration of the storm is (i) 60 min, (ii) 30 min, and (iii) 15 min. Assume a ϕ -index of 2.5 cm/hr for the entire basin. When the storm duration is 15 minutes, only drainage from 60% of the area of the basin reaches the concentration point.

Solution

$$Q = (i - \phi) A, \text{ where } i = \text{intensity of rainfall (cm/hr)}$$

$$(i) Q = (5 - 2.5) 80 = 200 \text{ ha-cm} = 200 \times 0.028 = 5.6 \text{ cumec}$$

$$(ii) Q = \left(\frac{5}{30} \times 60 - 2.5\right) 80 = 600 \text{ ha-cm} = 600 \times 0.028 = 16.8 \text{ cumec}$$

$$(iii) Q = \left(\frac{5}{15} \times 60 - 2.5\right) (0.60 \times 80) = 840 \text{ ha-cm} = 840 \times 0.028 = 23.52 \text{ cumec}$$

It is seen from (i) and (ii) that the peak discharge at the concentration point is maximum when the duration of storm is equal to the time of concentration, (iii) gives the highest flood, since only 60% of the area drains, the concentration time becomes less and the intensity of rainfall is very high during this time.

(v) *Rational Method.* The rational method is based on the application of the formula

$$Q = CiA \tag{8.9}$$

where C is a coefficient depending on the runoff qualities of the catchment called the *runoff coefficient* (0.2 to 0.8). The intensity of rainfall i is equal to the design intensity or critical intensity of rainfall i_c corresponding to the time of concentration t_c for the catchment for a given recurrence interval T ; the design intensity of rainfall $i (= i_c)$ can be found from the intensity-duration-frequency curves, for the catchment corresponding to t_c and T . If the intensity-duration-frequency curves, are not available for the catchment and a maximum precipitation of P cm occurs during a storm period of t_R hours, then the design intensity $i (= i_c)$ can be obtained from the equation

$$i_c = \frac{P}{t_R} \left(\frac{t_R + 1}{t_c + 1} \right) \quad \dots(8.10)$$

when the time of concentration, t_c is not known, $i_c \approx P/t_R$.

The values of the runoff coefficient C are given in Table 8.1 and serve as a rough guide.

Table 8.1 Value of the runoff coefficient C

| Type of terrain | Value of C |
|--|--------------|
| Flat residential areas | 0.4 |
| Moderately steep residential area | 0.6 |
| Built up areas—impervious | 0.8 |
| Rolling lands and clay-loam soils | 0.5 |
| Hilly areas, forests, clay and loamy soils | 0.5 |
| Flat cultivated lands and sandy soils | 0.2 |

Example 8.2 For an area of 20 hectares of 20 minutes concentration time, determine the peak discharge corresponding to a storm of 25-year recurrence interval. Assume a runoff coefficient of 0.6. From intensity-duration-frequency curves for the area, for $T = 25$ -yr, $t = 20$ min, $i = 12$ cm/hr.

Solution For $t = t_c = 20$ min, $T = 25$ -yr, $i = i_c = 12$ cm/hr

$$Q = CiA = 0.6 \times 12 \times 20 = 144 \text{ ha-cm/hr} = 144 \times 0.028 = \mathbf{4 \text{ cumec}}$$

Note 1 ha-cm/hr = $\frac{1}{36}$ cumec = 0.028 cumec

Example 8.3 Determine the design flood discharge (allowing an increase of one-third) for a bridge site with the following data:

Catchment area = 2×10^5 ha

Duration of storm = 8 hours

Storm precipitation = 3 cm

Time of concentration = 2 hr

Gauged discharge for a past flood with average maximum daily rainfall of 18 cm was 3400 cumec.

Solution From the past flood,

$$\begin{aligned} \text{Runoff coefficient, } C &= \frac{\text{Actual discharge}}{\text{Theoretical discharge}} \\ &= \frac{3400}{2 \times 10^5 \times 10^4 \times \frac{18}{100} \times \frac{1}{24 \times 60 \times 60}} = 0.815 \end{aligned}$$

Design or critical intensity of rainfall

$$i = i_c = \frac{P}{t_R} \left(\frac{t_R + 1}{t_c + 1} \right) = \frac{3}{8} \left(\frac{8 + 1}{2 + 1} \right) = 1.125 \text{ cm/hr}$$

$$Q = CiA = 0.815 \times 1.125 \times (2 \times 10^5) = 1.83 \times 10^5 \text{ ha-cm/hr}$$

or,

$$(1.83 \times 10^5) 0.028 = \mathbf{5130 \text{ cumec}}$$

From Inglis formula

$$Q = \frac{124 A}{\sqrt{A + 10.4}}, \text{ } A \text{ is in km}^2 \text{ and } 1 \text{ km}^2 = 100 \text{ ha}$$

$$\frac{124 \times 2000}{\sqrt{2000 + 10.4}} = \mathbf{5520 \text{ cumec}}$$

\therefore Design flood discharge = $5520 \times 1.33 = \mathbf{7350 \text{ cumec}}$

(vi) *The Unit Hydrograph Method.* For small and medium size basins ($A < 5000 \text{ km}^2$, *i.e.*, when a single unit hydrograph could be applied to the entire basin) in developing design flood hydrographs by applying the unit hydrograph for the basin, the design storm estimates are made by the following methods.

- (i) Selection of major storms
- (ii) Maximization of selected storms
- (iii) Plotting the depth-area-duration curves and their analysis
- (iv) Moisture adjustment
- (v) Storm transposition to a critical position
- (vi) Envelopment of the transposed adjusted storms
- (vii) Use of minimum infiltration indices

In the depth-area-duration analysis of a particular storm, the maximum average depths of rainfall over various sizes of area during certain periods of storm (hr or days), say cm over 1000 km^2 in 1 day, 2 days or 3 days from the isohyetal maps constructed (see Fig. 2.15). Such values determined for all the transposable storms provide the basic data to estimate the PMP over the basin.

Example 8.4 Computation of Maximum Probable Flood of River Tapi at Ukai

Since the catchment was partly surrounded by hills, depth-area-duration or storm transposition techniques were not considered proper and storm analysis was done on the basis of the catchment as the unit of study, *i.e.*, by the depth-duration method.

1. *Storm analysis.* From the 1-day, 2-days and 3-days isohyetal maps for the most severe 3-days storm of 1968 that occurred over the Tapi Basin up to Ukai (Central India) on 4th, 5th and 6th August 1968, the depth-duration curve was drawn and the weighted maximum rainfall depths for 1, 2 and 3 days are 11.43, 22.38 and 25.96 cm, respectively.

2. *Storm maximisation with respect to moisture charge.* Since the storm of 1968 had its centre inside the catchment on all the days of the storm, it was assumed that the highest efficiency had been already attained during the storm in respect of all other meteorological parameters except moisture content. The moisture adjustment factor, which is the ratio of maximum precipitable water at storm location to that available during storm period was derived with respect to standard level of 500 mb and was of the order of 1.23. The storm of 4–6 August 1968 was increased by 23% to arrive at maximum probable storm.

3. *Minimum infiltration losses.* For the storm of 1968, the rainfall of 25.96 cm had resulted in a surface runoff 11.7 cm with an infiltration loss of 14.26 cm. As the infiltration losses would be higher in the beginning of rainfall period and gradually decrease as the runoff proceeds, a varying rate of infiltration was adopted. The rainfall excesses were computed by deducting the losses from each 6-hour maximised storm values as given below:

| <i>Rainfall during 6-hr interval (cm)</i> | <i>Infiltration rate (cm/hr)</i> | <i>Infiltration loss in 6-hr interval (cm)</i> | <i>Rainfall excess (cm)</i> |
|---|--------------------------------------|--|-------------------------------------|
| 10.5 | 0.25 | 1.5 | 9.0 |
| 6.0 | 0.25 | 1.5 | 4.5 |
| 4.4 | 0.24 | 1.44 | 2.96 |
| 2.7 | 0.24 | 1.44 | 1.26 |
| 1.5 | 0.23 | 1.38 | 0.12 |
| 1.0 | 0.23 | 1.38 | – |
| 0.8 | 0.23 | 1.38 | – |
| 0.6 | 0.23 | 1.38 | – |
| 1.3 | 0.20 | 1.20 | 0.10 |
| 1.1 | 0.20 | 1.20 | – |
| 1.0 | 0.20 | 1.20 | – |
| 0.9 | 0.20 | 1.20 | – |
| 31.8 | | | 17.94 |
| Total loss = 31.80 – 17.94 = 13.86 cm | | | |

4. *Maximum probable flood hydrograph.* The 6-hour rainfall excesses were rearranged in a sequence so as to produce the most severe flood peak and then applied to the ordinates of the 6-hour design unit hydrograph derived from the 1968 flood hydrograph at Kakrapar weir at Ukai with a lag of 6 hours successively and the ordinates of the surface runoff hydrograph of the maximum probable flood arrived at. The constant base flow of 2400 cumec was then added to arrive at the final ordinates of the flood hydrograph of maximum probable flood (MPF). The peak of this hydrograph is 59800 cumec, Table 8.2, and is shown in Fig. 8.1. The highest peak attained during 1876-1968 (93 years) was 42500 cumec in August 1968 and the second highest was 37300 cumec in September 1959. The MPF recommended by CWPC, India for the design of Ukai dam was almost the same as 59800 cumec while the SPF recommended was around 48200 cumec. The design flood adopted was 49500 cumec.

5. *Limitation.* Unit hydrograph is generally applicable for catchments of less than 5000 km² since according to the theory, storm distribution over the area is assumed to be fairly even. The catchment of Tapi river up to Ukai dam is nearly 62000 km² which is considerably greater than the limit for unit hydrograph application. In such cases, the correct method would be to subdivide the whole catchment into a number of sub-basins, and separately carry out unit hydrograph application for these sub-basins, and thereafter to arrive at the maximum flood for the catchment by routing the flood through the various river reaches. But this method naturally requires extensive gauge and discharge data for the individual sub-basins and at the lowest side, as also intermediate cross section of the river channel for the whole reach in order to enable routing of the floods derived for the sub-basins. For Tapi, however, such extensive data was not available and the catchment could not be sub-divided into sub-basins; the whole catchment up to Ukai dam has been treated as a single unit.

Table 8.2 Computation of maximum probable flood of River Tapi at Ukai, A = 62000 km². (Example 8.4)

| Time (hr) | 6-hr UGO (cumec) | Rainfall excesses | | | | | | DRO sub-total (cumec) | BFO (cumec) | TRO (cumec) |
|--------------|---------------------|-------------------|------|-------|-------|------|-------|-----------------------------|----------------|----------------|
| | | 0.12 | 1.26 | 4.5 | 9.0 | 2.96 | | | | |
| 0 | 0 | 0 | | | | | 0 | 2400 | 2400 | |
| 6 | 279 | 31 | 0 | | | | 310 | 2400 | 2710 | |
| 12 | 935 | 105 | 35 | 0 | | | 1075 | 2400 | 3475 | |
| 18 | 1940 | 220 | 118 | 1256 | 0 | | 3534 | 2400 | 5934 | |
| 24 | 2500 | 283 | 244 | 4200 | 2512 | 0 | 9739 | 2400 | 12139 | |
| 30 | 3000 | 340 | 315 | 8700 | 8510 | 825 | 21690 | 2400 | 24090 | |
| 36 | 3340 | 378 | 378 | 11240 | 17500 | 2764 | 35600 | 2400 | 38000 | |
| 42 | 3220 | 364 | 420 | 13500 | 22520 | 5750 | 45774 | 2400 | 48174 | |
| 48 | 2940 | 333 | 405 | 15000 | 27000 | 7400 | 53078 | 2400 | 55478 | |
| 54 | 2660 | 301 | 370 | 14600 | 30600 | 8870 | 57401 | 2400 | 59801 ← peak | |
| 60 | 2050 | 233 | 335 | 13200 | 29000 | 9890 | 54708 | 2400 | 57108 | |
| 66 | 1280 | 145 | 258 | 11960 | 26480 | 9530 | 49653 | 2400 | 52053 | |
| 72 | 963 | 109 | 161 | 9200 | 23980 | 8700 | 43113 | 2400 | 45513 | |
| 78 | 775 | 88 | 121 | 5730 | 18500 | 7870 | 33084 | 2400 | 35484 | |
| 84 | 651 | 74 | 98 | 4330 | 11500 | 6070 | 22623 | 2400 | 25023 | |

(Contd...)
p. 220

| | | | | | | | | | |
|-----|-----|----|----|------|------|------|-------|------|-------|
| 90 | 540 | 61 | 82 | 3490 | 8170 | 3790 | 16133 | 2400 | 18533 |
| 96 | 418 | 47 | 68 | 2930 | 6980 | 2850 | 13293 | 2400 | 15693 |
| 102 | 329 | 37 | 53 | 2430 | 5860 | 2290 | 10999 | 2400 | 13399 |
| 108 | 267 | 30 | 41 | 1880 | 4860 | 1930 | 9007 | 2400 | 11407 |
| 114 | 212 | 24 | 34 | 1480 | 3770 | 1600 | 7120 | 2400 | 9520 |
| 120 | 156 | 18 | 27 | 1200 | 2960 | 1240 | 5601 | 2400 | 8001 |
| 126 | 111 | 13 | 20 | 950 | 2400 | 974 | 4468 | 2400 | 6868 |
| 132 | 86 | 10 | 14 | 698 | 1910 | 790 | 3508 | 2400 | 5908 |
| 138 | 58 | 7 | 11 | 497 | 1404 | 627 | 2604 | 2400 | 5004 |
| 144 | 31 | 4 | 7 | 387 | 1000 | 462 | 1891 | 2400 | 4291 |
| 150 | 0 | 0 | 4 | 261 | 774 | 329 | 1368 | 2400 | 3768 |
| 156 | | | 0 | 140 | 522 | 254 | 916 | 2400 | 3316 |
| 162 | | | | 0 | 279 | 172 | 451 | 2400 | 2851 |
| 168 | | | | | 0 | 92 | 92 | 2400 | 2492 |
| 174 | | | | | | 0 | 0 | 2400 | 2403 |

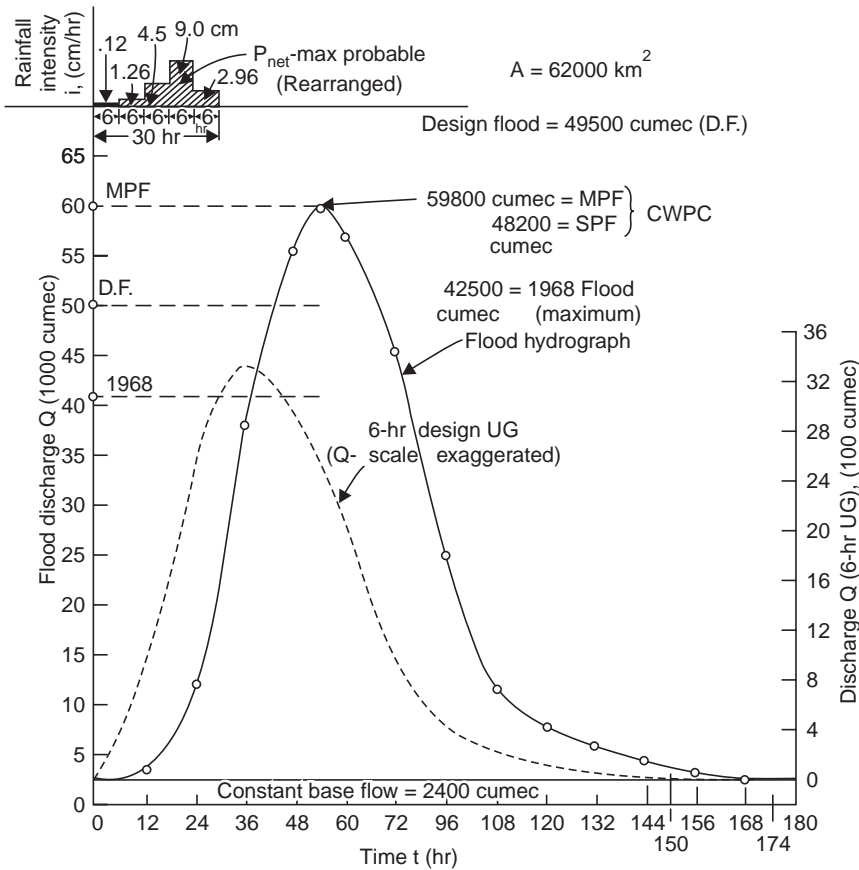

Fig. 8.1 MPF of river Tapi at Ukai (Example 8.4)

8.4 FLOOD FREQUENCY STUDIES

When stream flow peaks are arranged in the descending order of magnitude they constitute a statistical array whose distribution can be expressed in terms of frequency of occurrence. There are two methods of compiling flood peak data—the annual floods and the partial duration series. In the annual floods, only the highest flood in each year is used thus ignoring the next highest in any year, which sometimes may exceed many of the annual maximum. In the partial duration series, all floods above a selected minimum are taken for analysis, regardless of the time-interval, so that in some years there may be a number of floods above the basic stage, while in some other years there may not any such flood at all. The disadvantage of the partial duration series is that the data do not furnish a proper frequency (true distribution) series and so a reasonable statistical analysis cannot be made. But all the larger floods are used in this analysis, which is an advantage while in annual flood series some big floods are omitted because they were not the highest floods in any year considered. Usually the basic stage is assumed sufficiently low so that as many peaks (4 or 5) as possible each year are above this stage. The two series give very nearly the same recurrence interval for the larger floods, but the partial series indicates higher floods for shorter recurrence intervals. For information about floods of fairly frequent occurrence, as is required during the construction period of a large dam (say, 4-5 years), the partial series are the best, while for the spillway design flood the

annual series are preferable, since the flood should not be exceeded in the dam's life time, say 100 years.

Annual Flood Series The return period or recurrence interval (T) is the average number of years during which a flood of given magnitude will be equalled or exceeded once and is computed by one of the following methods.

California method (1923):

$$T = \frac{n}{m} \quad \dots(8.11)$$

Allen Hazen method (1930):

$$T = \frac{n}{m - \frac{1}{2}} = \frac{2n}{2m - 1} \quad \dots(8.11 a)$$

Weilbul method (1939):

$$T = \frac{n + 1}{m} \quad \dots(8.11 b)$$

where n = number of events, *i.e.*, years of record

m = order or rank of the event (flood item) when the flood magnitudes (items) are arranged in the descending order ($m = 1$ for the highest flood, $m = n$ for the lowest flood)

T = recurrence interval ($T = n$ -yr for the highest flood, $T = 1$ yr for the lowest flood, by California method)

The probability of occurrence of a flood (having a recurrence interval T -yr) in any year, *i.e.*, the probability of exceedance, is

$$P = \frac{1}{T} \quad \dots(8.12)$$

or the percent chance of its occurrence in any one year, *i.e.*, frequency (F) is

$$F = \frac{1}{T} \times 100 \quad \dots(8.12 a)$$

and the probability that it will not occur in a given year, *i.e.*, the probability of non-exceedance (P'), is

$$P' = 1 - P \quad \dots(8.12 b)$$

One interesting example of the application of statistics to a hydrologic problem (*i.e.*, stochastic hydrology), is Gumbel's theory of extreme values. The probability of an event of magnitude x not being equalled or exceeded (the probability of non-occurrence, P'), based on the argument that the distribution of floods is unlimited (*i.e.*, for large values of n , say $n > 50$),

$$P' = e^{-e^{-y}} \quad \dots(8.13)$$

and the probability of the event x being equalled or exceeded (*i.e.*, probability of occurrence, P) is

$$P = 1 - P' = 1 - e^{-e^{-y}} \quad \dots(8.13 a)$$

where e = base of natural logarithms

y = a reduced variate given by

$$y = \frac{1}{0.78\sigma} (x - \bar{x} + 0.45 \sigma), \quad \text{for } n > 50 \quad \dots(8.14)$$

x = flood magnitude with the probability of occurrence, P

\bar{x} = arithmetic mean of all the floods in the series

$$\bar{x} = \frac{\Sigma x}{n}, \quad \bar{x}^2 = \frac{\Sigma x^2}{n}$$

σ = standard deviation of the flood series

$$= \sqrt{\frac{\Sigma (x - \bar{x})^2}{n - 1}}$$

$$= \sqrt{\frac{n}{n - 1} [\bar{x}^2 - (\bar{x})^2]} \quad \dots(8.15)$$

$$= \sqrt{\frac{\Sigma x^2 - (\Sigma x)^2 / n}{n - 1}} \quad \dots(8.15 a)$$

n = number of items in the series, *i.e.*, the number of years of record.

and the recurrence interval of the event of magnitude x (See Chapter-15)

$$T = \frac{1}{P} = \frac{1}{1 - e^{-e^{-y}}} \quad \dots(8.16)$$

If the event x , of recurrence interval T -yr, is x_T , then from Eq. (8.14)

$$x_T = \bar{x} + \sigma (0.78 y - 0.45), \quad \text{for } n > 50 \quad \dots(8.17)$$

or in terms of flood discharge items.

$$Q_T = \bar{Q} + \sigma (0.78 \log_e T - 0.45), \quad \text{for } n > 50 \quad \dots(8.17 a)$$

$\bar{Q} = Q_T$, when $0.78y = 0.45$, or $y = 0.577$ which corresponds to $T = 2.33$ yr. The final plot of 'flood items (x) versus recurrence interval (T)' can be made on probability or semi-logarithmic paper. In the Gumbel-Powell probability paper, the plotting paper is constructed by laying out on a linear scale of y the corresponding values of T given by Eq. (8.16) (after Powell, R.W., 1943) and is given in Table 8.3. It is sufficient to calculate the recurrence interval of two flood flows, say mean flood \bar{x} (or \bar{Q} with $T = 2.33$ yr) and x_{150} or Q_{150} obtained from Eq. (8.17 *a*) putting $T = 150$, and to draw a straight line through these points. A third point serves as a check, Fig. 8.2. This straight line can then be extrapolated to read the flood magnitude against any desired return period (T). The Gumbel distribution does not provide a satisfactory fit for partial duration floods or rainfall data.

Actual observations of flood data reveal that there are a greater number of floods below the mean than those above it and variations above the mean are greater than those below the mean. Therefore, a curve which fits the maximum 24-hour annual flood data on a log-log paper will not be a symmetrical curve, but a 'skew curve' which is unsymmetrical, *i.e.*, the points do not lie on a straight line but the line bends off. The general slope of this curve is given by the coefficient of variation C_v , and the departure from the straight line is given by the coefficient of skew C_s . While plotting the skew probability curves, three parameters have to be calculated from observed flood data as

$$(i) \text{ Coefficient of variation, } C_v = \frac{\sigma}{\bar{x}} \quad \dots(8.18)$$

$$(ii) \text{ Coefficient of skew, } C_s = \frac{\Sigma (x - \bar{x})^3}{(n - 1) \sigma^3} \text{ (Foster)} \quad \dots(8.19)$$

$$(iii) \text{ Coefficient of flood, } C_f = \frac{\bar{x}}{A^{0.8/2.14}} \quad \dots(8.20)$$

where A = area of the catchment in km^2

Table 8.3 Gumbel's probability data

| Reduced variate (<i>y</i>) | Recurrence interval (<i>T</i>) | Probability of exceedance (<i>P</i>) |
|---------------------------------|-------------------------------------|---|
| - 1.53 | 1.01 | 0.99 (≈ 1.0) |
| - 0.475 | 1.25 | 0.80 |
| 0 | 1.58 | 0.63 |
| 0.37 | 2.00 | 0.50 |
| 0.58 | 2.33 | 0.43 |
| 1.50 | 5 | 0.20 |
| 2.25 | 10 | 0.10 |
| 2.97 | 20 | 0.05 |
| 3.90 | 50 | 0.02 |
| 4.60 | 100 | 0.01 |
| 5.30 | 200 | 0.005 |
| 5.70 | 300 | 0.0033 |
| 6.00 | 403 | 0.0025 |
| 6.24 | 500 | 0.002 |
| 6.92 | 1000 | 0.001 |
| 7.62 | 2000 | 0.0005 |
| 8.54 | 5000 | 0.0002 |
| 9.92 | 10000 | 0.0001 |

% Chance or probability of flood $\geq Q$, in any one year

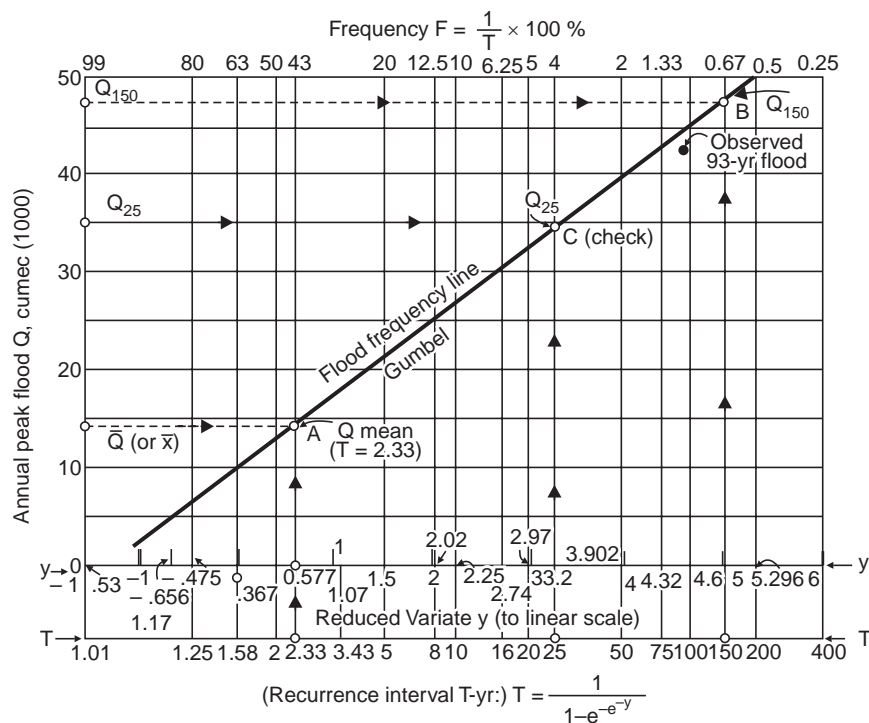

Fig. 8.2 Gumbel-Powell probability paper

When the flood items are tabulated in terms of mean flood, $C_v = \sigma$. If the annual flood is x and the mean flood is \bar{x} , then the annual flood in terms of mean flood is x/\bar{x} . The coefficient of variation for annual precipitation data is equal to the standard deviation of the indices of wetness.

While a small value of C_v indicates that all the floods are nearly of the same magnitude, a large C_v indicates a range in the magnitude of floods. In other word C_v represents the slope of the probability curve, and the curve is horizontal if $C_v = 0$. The actual length of records available has a very little effect on the value of C_v , *i.e.*, C_v for a 20-yr record varies very little from that for a 100-yr record.

The coefficient of skew, C_s is seriously affected by the length of record and will be too small for a short period; C_s is then modified to allow for the period of record (n) by multiplying by a factor $(1 + k/n)$ where the constant $K = 6$ to 8.5. If even this adjusted C_s does not give a curve to fit actual observed data, an arbitrary value of C_s will have to be assumed to fit the curve for the given annual flood data. From this theoretical curve can then be read off the probability or the percentage of time, of a flood of any given magnitude occurring, usually,

$$C_s \approx 2 C_v \quad \dots(8.21)$$

The coefficient of flood indicates the general magnitude of the floods in the particular stream; hence, it fixes the height of the curve above the base. Using C_f , the mean flood of a stream, for which no flood data are available, can be got, as

$$\text{Mean flood} = C_f \times \frac{A^{0.8}}{2.14} \quad \dots(8.22)$$

The exponent 0.8 is the slope of the line obtained by plotting the mean annual flood against water-shed area for a number of streams. Almost all observed data till to-date confirm this value originally obtained by Fuller.

8.5 ENCOUNTER PROBABILITY

Even if a flood of a long recurrence interval is chosen, there is always a possibility that the flood can be exceeded more than once during the interval. The probability of ' r ' events occurring in ' N ' possible events is given by

$$P_{(N, r)} = \frac{N!}{r!(N-r)!} P^r (1-P)^{N-r} \quad \dots(8.23)$$

where P = probability of a single event.

If $r = 0$, the flood will not be exceeded during the ' N ' years, the useful life of the structure. Then Eq. (8.23) becomes

$$\text{Probability of non-exceedance, } P_{(N, 0)} = (1-P)^N \quad \dots(8.23 a)$$

So, the probability that the design flood (T -year flood, annual probability of occurrence $P = 1/T$) will be exceeded one or more times during N year (useful life of the structure) is given by

$$\text{Probability of exceedance, } P_{Ex} = 1 - (1-P)^N \quad \dots(8.23 b)$$

$$\text{and the percentage risk} = P_{Ex} \times 100 \quad (8.23 c)$$

Thus, the probability of a 100-year flood will not be exceeded in the next 50 years is

$$P_{(N, 0)} = \left(1 - \frac{1}{100}\right)^{50} = 0.6 \text{ or } 60\%$$

or 6 chances in 10; and the probability that the 100-year flood will be exceeded once or more during the next 50 years is

$$P_{Ex} = 1 - 0.6 = 0.4 \text{ or } 40\%$$

or 4 chances in 10

As another example, to determine the recurrence interval of a design flood having a 63% risk of being exceeded during a 100-year period

$$P_{Ex} = 1 - (1 - P)^N$$

$$0.63 = 1 - (1 - P)^{100}$$

from which $P = 0.01$. Hence, $T = \frac{1}{P} = \frac{1}{0.01} = 100$ years.

The percentage probabilities of floods (or rainfall) of different recurrence intervals (T) to occur in particular periods (N) are given in Table 8.4.

Table 8.4 Probability (%) of T -yr flood to occur in a period of N -years

| Period (N -years) | Average recurrence interval of flood (T -yr) | | | | |
|----------------------|---|------|----|------|-----|
| | 5 | 10 | 50 | 100 | 200 |
| 1 | 20 | 10 | 2 | 1 | 0.5 |
| 5 | 67 | 41 | 10 | 5 | 2 |
| 10 | 89 | 65 | 18 | 10 | 5 |
| 25 | 99.6 | 93 | 40 | 22 | 12 |
| 50 | — | 99.5 | 64 | 40 | 22 |
| 100 | — | — | 87 | 63 | 39 |
| 200 | — | — | 98 | 87 | 63 |
| 500 | — | — | — | 99.3 | 92 |

Partial duration curve method Partial duration curves are plotted showing the flood discharges against their probable frequency of occurrence in 100 years and not against percentage of time as in the annual flood series.

$$\text{Probable frequency} = \frac{m}{y} \times 100 \quad \dots(8.24)$$

where m = order number or rank of the particular flood in the series of items selected and arranged in the descending order of magnitude

y = total length of record in years

The number of flood items selected need not be greater than the number of years in record to simplify the procedure. Gumbel paper should not be used for partial series, which usually plot better on semi-log paper.

Frequency method may be used for drainage basins of any size. The reliability of the frequency estimates depends on the length of the observed record rather than the method of probability analysis. Thus, if a 50-year record is available, a 10-yr flood may be predicted with

assurance, while the 50-yr or 100-yr floods could be estimated only very approximately. The procedure in frequency analysis is (i) compilation of flood peaks in the descending order of magnitude, (ii) computation of recurrence intervals by any one of the stochastic methods, and (iii) plotting 'the flood peaks versus recurrence interval' from which the flood (or rainfall) of a required recurrence interval can be read or extrapolated, or the recurrence interval for a given flood magnitude (or rainfall) can be read or extrapolated.

The limitations of frequency methods are that the greatest floods are caused by an unusual meteorological combination resulting in unexpected peculiar storms. Hence, the probability studies alone are inadequate for predicting floods of very great magnitudes.

Example 8.5 Flood frequency studies are made for the 30-year flood data (from 1939-1968) of lower Tapi river at Ukai as shown in Table 8.5 both by Weibull and Gumbel's methods.

(a) Gumbel's method

$$n = 30, \text{ mean flood } \bar{x} = \frac{426.27}{30} = 14.21 \text{ or } 14210 \text{ cumec}$$

Standard deviation of the annual flood series,

$$\sigma = \sqrt{\frac{\sum (x - \bar{x})^2}{n - 1}} = \sqrt{\frac{2724.26}{30 - 1}} = 9.7$$

Recurrence interval of mean flood of 14.21 thousand cumec is 2.33 yr. Flood magnitude Q_{100} having a recurrence interval of 100-yr is given by

$$Q_T = \bar{Q} + \sigma (0.78 \log_e T - 0.45)$$

$$Q_{100} = 14.21 + 9.7(0.78 \log_e 100 - 0.45) = 44.65 \text{ or } 44650 \text{ cumec}$$

plot the reduced variate 'y' to a linear scale on the x-axis and the flood magnitudes on the y-axis to natural scale (Fig. 8.3). Plot the first point to A as $\bar{x} = \bar{Q} = 14.21$ thousand cumec against $y = 0.577$ corresponding to $T = 2.33$ yr. Plot the second point B as $x_{100} = Q_{100} = 44.65$ thousand cumec against $y = 4.6$ corresponding to $T = 100$ yr. Join AB and produce which will yield a straight plot. Take a third point C as, say Q_{50} given by

$$Q_{50} = 14.21 + 9.7 (0.78 \times 3.9 - 0.45)$$

since for $T = 50$ yr, $y = 3.9$

$$\therefore Q_{50} = 39.31 \text{ thousand cumec}$$

Now plot C as 39.310 cumec against $y = 3.9$, which lies on the straight line plot AB. Similarly, several points can be located on the straight line plot but a third point C is enough to check the straight line plot.

Below the x-axis, write the values of T corresponding to the reduced variate y . On the horizontal axis on the top of the graph, the percentage probability $P(= 100/T)$ is plotted vertically above the corresponding T -values. Now from the graph, the statistical information required can be read or extrapolated as

- (i) 150-yr flood ($T = 150$ yr), $Q = 47500$ cumec
- (ii) 20-yr flood ($T = 20$ yr, $y = 2.97$, $P = 5\%$), $Q = 32000$ cumec
- (iii) 10-yr flood ($T = 10$ yr, $y = 2.25$, $P = 10\%$), $Q = 26750$ cumec

(iv) For a peak flood (Q) of 40,000 cumec, $y = 4.0$, $T = 55$ yr

(v) For the SPF of 48200 cumec, extrapolate to get $y = 5.05$, $T = 156$ yr.

Hence, the SPF recommended by CWPC seems to be a feasible one.

(vi) Frequency of 1968 flood of 42500 cumec, $T = 74$ yr and $P = 1.35\%$; but actually it occurred in 93 years (1876-1968).

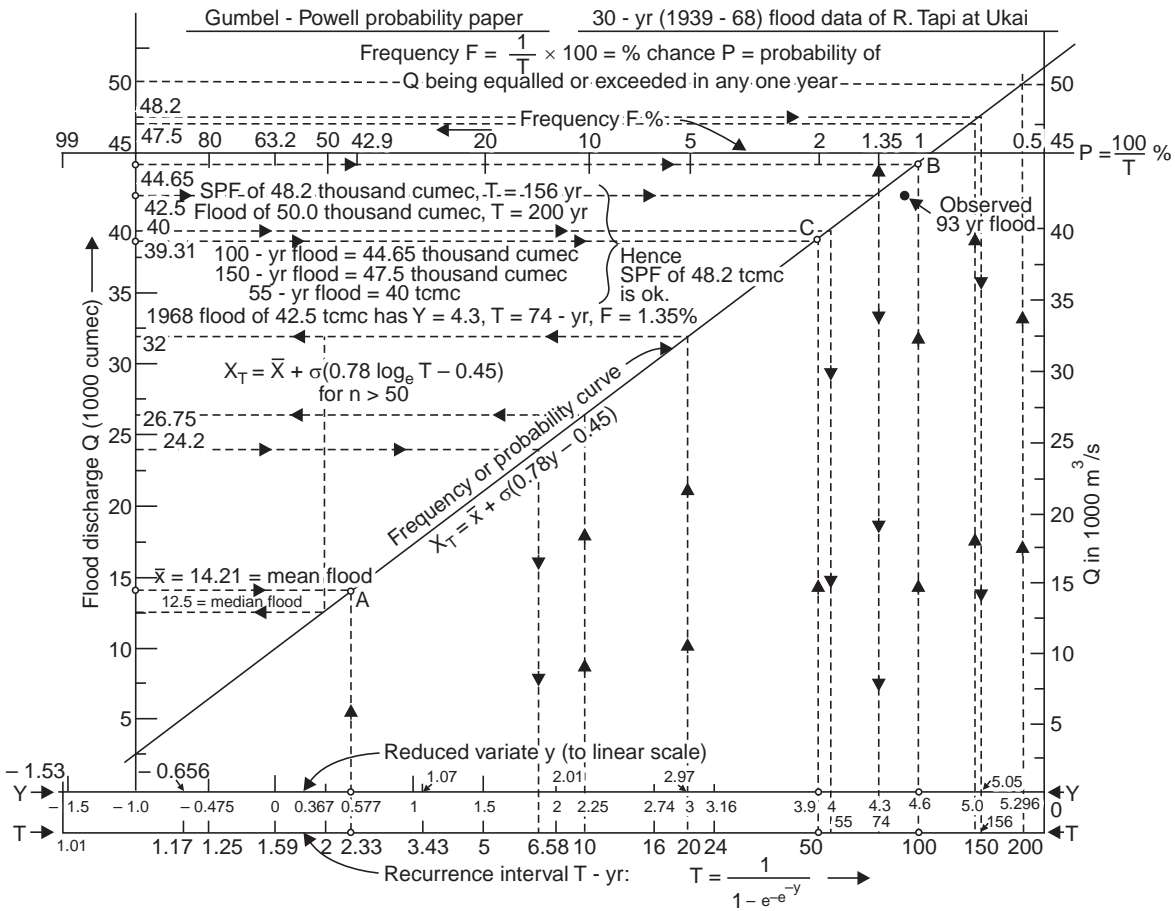

Fig. 8.3 Frequency curve of annual floods-Gumbel's method (Example 8.5)

Coefficient of variation, $C_v = \frac{\sigma}{\bar{x}} = \frac{9.7}{14.21} = 0.68$

Coefficient of skew, $C_s = \frac{\sum (x - \bar{x})^3}{(n - 1) \sigma^3} = \frac{34319}{(30 - 1)(9.7)^3} = 1.3$

Note that $C_s \approx 2C_v$

C_s adjusted to allow for the period of record (Foster, 1924)

$$\bar{C}_s = C_s \left(1 + \frac{k}{n} \right) = 1.3 \left(1 + \frac{6}{30} \right) = 1.56$$

For Foster's Type I curve $k = 6$, and for Type III curve $k = 8.5$

Table 8.5 Flood frequency studies of Lower Tapi River at Ukai (Western India) : (1939-1968 (30 years) (Example 8.5))

| Year | Annual Maximum ¹ 1-day flood x in 1000 cumec (in descending order) | Weibull's method | | | Gumbel's method | | | | | | Remarks |
|-------|---|--|--|---|-----------------------------------|-------------------|--|--|---|---|---|
| | | Rank (no. of times equalled or exceeded (m)) | Recurrence interval $T = \frac{n+1}{m}$ year | Per cent Probability $P = \frac{1}{T} \times 100\%$ | $x - \bar{x}$ | $(x - \bar{x})^2$ | $*(x - \bar{x})^3$ | Reduced variate [†] $y = \frac{(x - \bar{x}) + 0.45 \sigma}{0.7797 \sigma}$ | Recurrence interval, yr $T = \frac{1}{1 - e^{-e^{-y}}}$ | Per cent probability $P = \frac{1}{T} \times 100\%$ | |
| 1968 | 42.45 | 1 | 31 | 3.22 | 28.24 | 798 | 22600 | 4.31 | 74 | 1.35 | <p>(i) Mean flood, $\bar{x} = \frac{\Sigma x}{n} = \frac{426.27}{30} = 14.21$ tcm or 14210 cumec</p> <p>(ii) Median flood = 12500 cumec (for P = 50% from Fig. 8.3)</p> <p>(iii) Standard deviation,</p> $\sigma = \sqrt{\frac{\Sigma(x - \bar{x})^2}{n - 1}} = \sqrt{\frac{2724.26}{30 - 1}} = 9.7$ <p>(iv) Coefficient of variation,</p> $C_v = \frac{\sigma}{\bar{x}} = \frac{9.7}{14.21} = 0.68$ <p>(v) Coefficient of skew,</p> $C_s = \frac{\Sigma(x - \bar{x})^3}{(n - 1) \sigma^3} = \frac{34319}{(30 - 1)(9.7)^3} = 1.3, (C_s = 2C_v)$ <p>(vi) C_s (adjusted)</p> $\bar{C}_s = C_s \left(1 + \frac{k}{n}\right) = 1.3 \left(1 + \frac{6}{30}\right) = 1.56$ <p>(vii) Coefficient of flood,</p> $C_f = \frac{\bar{x}}{A^{0.8}/2.14} = \frac{14210}{(62000)^{0.8}/2.14} = 4.46$ <p>[†]for $n > 50$; for any sample size (n):</p> $y_T = - \left[\ln \cdot \ln \frac{T}{T - 1} \right]$ $= - \left[0.834 + 2.303 \log \log \frac{T}{T - 1} \right]$ $Q_T = \bar{Q} + k\sigma, \quad k = \frac{y - \bar{y}_n}{\sigma_n}, \quad y = y_T$ <p>for \bar{y}_n & σ_n, see Table 15.1, Chapter-15 ; also, see Table 15.2, for K</p> |
| 1959 | 37.30 | 2 | 15.5 | 6.45 | 23.09 | 537 | 12400 | 3.63 | 38 | 2.63 | |
| 1944 | 29.30 | 3 | 10.3 | 9.70 | 15.09 | 227 | 3430 | 2.57 | 13 | 7.7 | |
| 1945 | 24.20 | 4 | 7.75 | 12.9 | 9.99 | 99.9 | 1000 | 1.90 | 7 | 14.3 | |
| 1942 | 22.62 | 5 | 6.2 | 16.1 | 8.41 | 70.7 | 595 | 1.69 | 5.5 | 18.2 | |
| 1954 | 21.24 | 6 | 5.17 | 19.35 | 7.03 | 49.4 | 347 | 1.51 | 5 | 20.0 | |
| 1961 | 20.86 | 7 | 4.43 | 22.55 | 6.65 | 44.2 | 294 | 1.46 | 4.8 | 20.8 | |
| 1958 | 19.65 | 8 | 3.87 | 25.80 | 5.44 | 29.6 | 161 | 1.30 | 3.7 | 27.0 | |
| 1962 | 18.70 | 9 | 3.44 | 29.10 | 4.49 | 20.2 | 91 | 1.17 | 3.3 | 30.3 | |
| 1949 | 18.30 | 10 | 3.1 | 32.30 | 4.09 | 16.7 | 68 | 1.12 | 3.1 | 32.2 | |
| 1939 | 14.57 | 11 | 2.82 | 35.5 | 0.36 | 0.13 | 0.05 | 0.63 | | | |
| 1941 | 14.00 | 12 | 2.58 | 38.8 | -0.21 | 0.04 | -0.01 | 0.55 | 2.3 | 43.5 | |
| 1967 | 12.88 | 13 | 2.38 | 42.0 | -1.33 | 1.77 | -2.36 | 0.40 | | | |
| 1946 | 12.45 | 14 | 2.21 | 45.2 | -1.76 | 3.10 | -8.45 | 0.34 | 2.0 | 50.0 | |
| 1953 | 11.43 | 15 | 2.07 | 48.3 | -2.78 | 7.72 | -21.50 | 0.21 | | | |
| 1966 | 10.34 | 16 | 1.94 | 51.5 | -3.87 | 15.0 | -58.20 | 0.06 | | | |
| 1956 | 9.72 | 17 | 1.83 | 54.7 | -4.49 | 20.2 | -90.80 | -0.02 | | | |
| 1950 | 9.68 | 18 | 1.72 | 58.0 | -4.53 | 20.6 | -93.5 | -0.023 | | | |
| 1955 | 8.50 | 19 | 1.63 | 61.3 | -5.71 | 32.6 | -186.0 | -0.18 | | | |
| 1940 | 8.44 | 20 | 1.55 | 64.5 | -5.77 | 33.2 | -192.0 | -0.19 | | | |
| 1963 | 7.65 | 21 | 1.48 | 67.5 | -6.56 | 43.1 | -283.0 | -0.29 | | | |
| 1947 | 7.27 | 22 | 1.41 | 71.0 | -6.94 | 48.1 | -334.0 | -0.34 | | | |
| 1960 | 7.22 | 23 | 1.35 | 74.0 | -6.99 | 48.9 | -342.0 | -0.35 | | | |
| 1951 | 6.48 | 24 | 1.29 | 77.5 | -7.73 | 59.8 | -463.0 | -0.44 | | | |
| 1948 | 6.23 | 25 | 1.24 | 80.6 | -7.98 | 63.7 | -508.0 | -0.48 | 1.25 | 80 | |
| 1964 | 6.09 | 26 | 1.23 | 81.2 | -8.12 | 66.0 | -536.0 | -0.50 | | | |
| 1957 | 5.81 | 27 | 1.15 | 87.0 | -8.40 | 70.6 | -593.0 | -0.55 | | | |
| 1943 | 4.82 | 28 | 1.11 | 90.0 | -9.39 | 88.2 | -828.0 | -0.67 | | | |
| 1965 | 4.39 | 29 | 1.07 | 93.5 | -9.82 | 96.3 | -945.0 | -0.72 | | | |
| 1952 | 3.68 | 30 | 1.03 | 97.0 | -10.53 | 112.2 | -1183.0 | -0.82 | | | |
| Total | $\Sigma x = 426.27$ | $n = 30$ | | | $\Sigma(x - \bar{x})^2 = 2724.26$ | | $34319 = (x - \bar{x})^3$ (algebraic sum) = (40986 - 6667) | | | | |

¹Mean daily flow *Required to calculate C_s only; tcm = 1000 cumec

Coefficient of flood, $C_f = \frac{\bar{x}}{A^{0.8}/2.14} = \frac{14210}{(62000)^{0.8}/2.14} = 4.46$

(b) *Foster's Method* From the value of \bar{C}_s , the values of the factor K giving the variations of the peak flood from the mean flood at various percentages of time (*i.e.*, probability $P\%$) can be obtained by referring to the Tables 8.6 and 8.7 prepared by Foster. From this, the flood frequency curve can be drawn; and the probability and recurrence interval ($T = 1/P \times 100$) of a desired flood magnitude can be read off from the curve.

In Example 8.5, for $\bar{Q} = 14.21$ tcm, $\sigma = 9.7$ tcm, $\bar{C}_s = 1.56$, from Table 8.6, the flood frequencies can be determined as follows (tcm = thousand cumec):

| Frequency P (%) | Recurrence interval (T -yr) | Skew curve factor K (from Table 8.6 for $\bar{C}_s = 1.6$) | Variation from the mean flood $K\sigma$ (tcm) | Flood peak $Q_T = \bar{Q} + K\sigma$ (tcm) |
|----------------------|--------------------------------------|--|--|--|
| 0.01 | 10000 | 5.67 | 52.1 | 66.31 |
| 0.1 | 1000 | 4.75 | 43.7 | 57.91 |
| 1 | 100 | 3.40 | 31.25 | 45.46 |
| 5 | 20 | 2.07 | 19.05 | 33.26 |
| 20 | 5 | 0.69 | 6.35 | 20.56 |
| 50 | 2 | -0.32 | -2.94 | 11.27 |
| 100 | 1 | -0.96 | -9.32 | 4.89 |

The frequency curve is shown in Figs. 8.4 and 15.1. While the highest flood observed in 93 years (1876-1968) is 42.5 tcm, the 100-year flood by Foster's Type I curve is predicted as 45.46 tcm.

Table 8.6 Skew Curve Factors (K values) for Foster's Type I curve

| \bar{C}_s | Frequency P (%) | | | | | | | | | | |
|-------------|-------------------|-------|-------|-------|------|------|------|------|------|-------|--------|
| | 99 | 95 | 80 | 50 | 20 | 5 | 1 | 0.1 | 0.01 | 0.001 | 0.0001 |
| 0 | -2.08 | -1.64 | -0.92 | 0 | 0.92 | 1.64 | 2.08 | 2.39 | 2.53 | 2.59 | 2.62 |
| 0.2 | -1.91 | -1.56 | -0.93 | -0.05 | 0.89 | 1.72 | 2.25 | 2.66 | 2.83 | 2.94 | 3.00 |
| 0.4 | -1.75 | -1.47 | -0.93 | -0.09 | 0.87 | 1.79 | 2.42 | 2.95 | 3.18 | 3.35 | 3.44 |
| 0.6 | -1.59 | -1.38 | -0.92 | -0.13 | 0.85 | 1.85 | 2.58 | 3.24 | 3.59 | 3.80 | 3.92 |
| 0.8 | -1.44 | -1.30 | -0.91 | -0.17 | 0.83 | 1.90 | 2.75 | 3.55 | 4.00 | 4.27 | 4.43 |
| 1.0 | -1.30 | -1.21 | -0.89 | -0.21 | 0.80 | 1.95 | 2.92 | 3.85 | 4.42 | 4.75 | 4.95 |
| 1.2 | -1.17 | -1.12 | -0.86 | -0.25 | 0.77 | 1.99 | 3.09 | 4.15 | 4.83 | 5.25 | 5.50 |
| 1.4 | -1.06 | -1.03 | -0.83 | -0.29 | 0.73 | 2.03 | 3.25 | 4.45 | 5.25 | 5.75 | 6.05 |
| 1.6 | -0.96 | -0.95 | -0.80 | -0.32 | 0.69 | 2.07 | 3.40 | 4.75 | 5.67 | 6.25 | 6.65 |
| 1.8 | -0.87 | -0.87 | -0.76 | -0.35 | 0.64 | 2.10 | 3.54 | 5.05 | 6.08 | 6.75 | 7.20 |
| 2.0 | -0.80 | -0.79 | 0.71 | -0.37 | 0.58 | 2.13 | 3.67 | 5.35 | 6.50 | 7.25 | 7.80 |

Table 8.7 Skew Curve Factors (*K* values) for Foster's Type-III curve

| \bar{C}_s | Frequency <i>P</i> (%) | | | | | | | | | | |
|-------------|------------------------|-------|-------|-------|------|------|------|------|------|-------|--------|
| | 99 | 95 | 80 | 50 | 20 | 5 | 1 | 0.1 | 0.01 | 0.001 | 0.0001 |
| 0 | -2.33 | -1.64 | -0.84 | 0 | 0.84 | 1.64 | 2.33 | 3.09 | 3.73 | 4.27 | 4.76 |
| 0.2 | -2.18 | -1.58 | -0.85 | -0.03 | 0.83 | 1.69 | 2.48 | 3.08 | 4.16 | 4.84 | 5.48 |
| 0.4 | -2.03 | -1.51 | -0.85 | -0.06 | 0.82 | 1.74 | 2.62 | 3.67 | 4.60 | 5.42 | 6.24 |
| 0.6 | -1.88 | -1.45 | -0.86 | -0.09 | 0.80 | 1.79 | 2.77 | 3.96 | 5.04 | 6.01 | 7.02 |
| 0.8 | -1.74 | -1.38 | -0.86 | -0.13 | 0.78 | 1.83 | 2.90 | 4.25 | 5.48 | 6.61 | 7.82 |
| 1.0 | -1.59 | -1.31 | -0.86 | -0.16 | 0.76 | 1.87 | 3.03 | 4.54 | 5.92 | 7.22 | 8.63 |
| 1.2 | -1.45 | -1.25 | -0.85 | -0.19 | 0.74 | 1.90 | 3.15 | 4.82 | 6.37 | 7.85 | 9.45 |
| 1.4 | -1.32 | -1.18 | -0.84 | -0.22 | 0.71 | 1.93 | 3.28 | 5.11 | 6.82 | 8.50 | 10.28 |
| 1.6 | -1.19 | -1.11 | -0.82 | -0.25 | 0.68 | 1.96 | 3.40 | 5.39 | 7.28 | 9.17 | 11.12 |
| 1.8 | -1.08 | -1.03 | -0.80 | -0.28 | 0.64 | 1.98 | 3.50 | 5.66 | 7.75 | 9.84 | 11.96 |
| 2.0 | -0.99 | -0.95 | -0.78 | -0.31 | 0.61 | 2.00 | 3.60 | 5.91 | 8.21 | 10.51 | 12.81 |
| 2.2 | -0.90 | -0.89 | -0.75 | -0.33 | 0.58 | 2.01 | 3.70 | 6.20 | | | |
| 2.4 | -0.83 | -0.82 | -0.71 | -0.35 | 0.54 | 2.01 | 3.78 | 6.47 | | | |
| 2.6 | -0.77 | -0.76 | -0.68 | -0.37 | 0.51 | 2.01 | 3.87 | 6.73 | | | |
| 2.8 | -0.71 | -0.71 | -0.65 | -0.38 | 0.47 | 2.02 | 3.95 | 6.99 | | | |
| 3.0 | -0.67 | -0.66 | -0.62 | -0.40 | 0.42 | 2.02 | 4.02 | 7.25 | | | |

In the given example, the 1945 flood of 24200 cumec was exceeded in 1959 (when the flood was 37300 cumec), *i.e.*, in 14 years. From the graph for $Q = 24200$ cumec, $T = 6.5$ yr (7.75-yr-Weibull); $P = 100/6.5 = 15\%$. The probability that this flood will not occur in the next 14 years is

$$P_{(N, 0)} = (1 - 0.15)^{14} = 0.10 \text{ or } 10\%$$

and the probability of its occurrence in the next 14 years is

$$P_{Ex} = 1 - 0.1 = 0.90 \text{ or } 90\%$$

but actually it is exceeded after 14 years.

(c) *Weibull's Method* The Weibull's distribution will not give a straight line plot on the Gumbel-Powel probability paper and hence can better be plotted on a log-log paper. Both the Gumbell's and Weibull's curves are plotted on log-log paper in Fig. 8.4 for comparison. It can be seen that for smaller floods (say, $m \geq 5$) both the methods give the same plotting positions; but for the larger floods ($m < 5$), the Weibull's method gives lower recurrence interval, *i.e.*, largest floods of increased frequency. For example from the Weibull's frequency curve in Fig. 8.4, for the SPF of 48.2 thousand cumec, $T = 48$ yr, while by the Gumbel's method $T = 160$ yr for the same SPF); for $T = 100$ yr, $Q = 60$ thousand cumec.

(d) *Fuller's formula*

$$\begin{aligned} Q &= CA^{0.8} (1 + 0.8 \log T) (1 + 2.76A^{-0.3}) \\ Q_{100} &= 2.27 (62000)^{0.8} (1 + 0.8 \log 100) [1 + 2.76 (62000)^{-0.3}] \\ &= \mathbf{40700 \text{ cumec}} \text{ (100-yr flood)} \end{aligned}$$

against Gumbel's 44650 cumec.

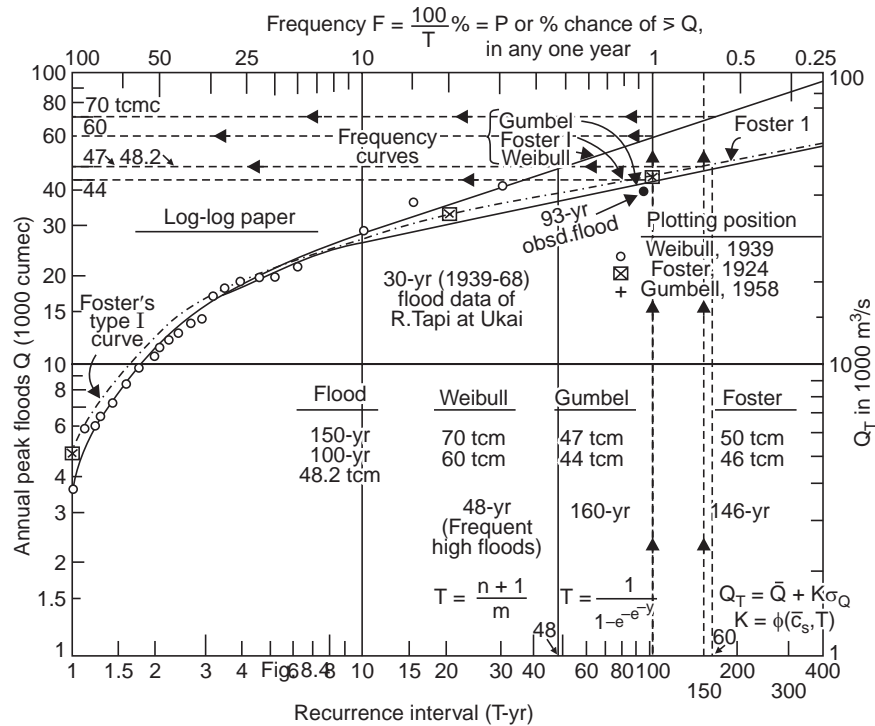

Fig. 8.4 Log-log plot of flood frequency (Example 8.5)

(e) Creager's formula

$$Q = C(0.386 A)^{0.894(0.386 A)^{-0.048}}$$

$$= 140 (0.386 \times 62000)^{0.894(0.386 \times 62000)^{-0.048}}$$

= **36000 cumec**, which was well exceeded in the year 1968 when the peak flood was 42500, cumec.

Hence, the Gumbel's method gives the most probable maximum flood in the life period of a structure to be designed and can be adopted in the safe design of hydraulic structures.

(f) World enveloping flood formula (J.M. Baird and J.F. Meillnraith)

$$Q = \frac{3010 A}{(277 + A)^{0.78}} = \frac{3010 \times 62000}{(277 + 62000)^{0.78}} = \mathbf{33500 \text{ cumec}}$$

which was well exceeded in the year 1968.

(g) Rational formula

$$Q = CiA$$

i = design intensity of rainfall (= i_c)
= 31.8 cm in 3 days during Aug. 4-6, 1968

(See the Introduction part of Chapter 1)

C = runoff coefficient = 0.43, from the 3-day storm of Aug. 1968
 A = 62000 km² = 62 × 10⁵ ha

Since 1 ha-cm/hr = 1/36 cumec

$$Q = \frac{1}{36} \left(0.43 \times \frac{31.8 \text{ cm}}{72 \text{ hr}} \times 62 \times 10^5 \text{ ha} \right) = 32700 \text{ cumec}$$

which has been exceeded in the year 1968. However, the peak flood obtained by the rational formula depends upon the accuracy of the coefficient of runoff assumed.

Example 8.6 *Twenty largest one-day floods (without respect to time) are selected in a period of 20 years arranged in the descending order of magnitude (cumec). Draw the partial duration curve:*

501, 467, 371, 351, 351, 345, 334, 311, 283, 273,
266, 264, 221, 214, 194, 193, 182, 175, 173, 163.

Solution The computations are shown in Table 8.8.

Table 8.8 Computation for partial duration curve

| Sl. no. | Flood flow (cumec) | Probable frequency in 100 years |
|---------|--------------------|---------------------------------|
| 1 | 501 | 5* |
| 2 | 467 | 10 |
| 3 | 371 | 15 |
| 4 | 351 | 20 |
| 5 | 351 | 25 |
| 6 | 345 | 30 |
| 7 | 334 | 35 |
| 8 | 311 | 40 |
| 9 | 283 | 45 |
| 10 | 273 | 50 |
| 11 | 266 | 55 |
| 12 | 264 | 60 |
| 13 | 221 | 65 |
| 14 | 214 | 70 |
| 15 | 194 | 75 |
| 16 | 193 | 80 |
| 17 | 182 | 85 |
| 18 | 175 | 90 |
| 19 | 173 | 95 |
| 20 | 163 | 100 |

$$*\text{Probable frequency} = \frac{m}{y} \times 100 = \frac{1}{20} \times 100 = 5$$

The partial duration curves are plotted on both log-log paper and semi-log paper as shown in Fig. 8.5 (a) and (b) respectively; the 100-yr flood is extrapolated as 640 and 810 cumec from the curves (a) and (b), respectively.

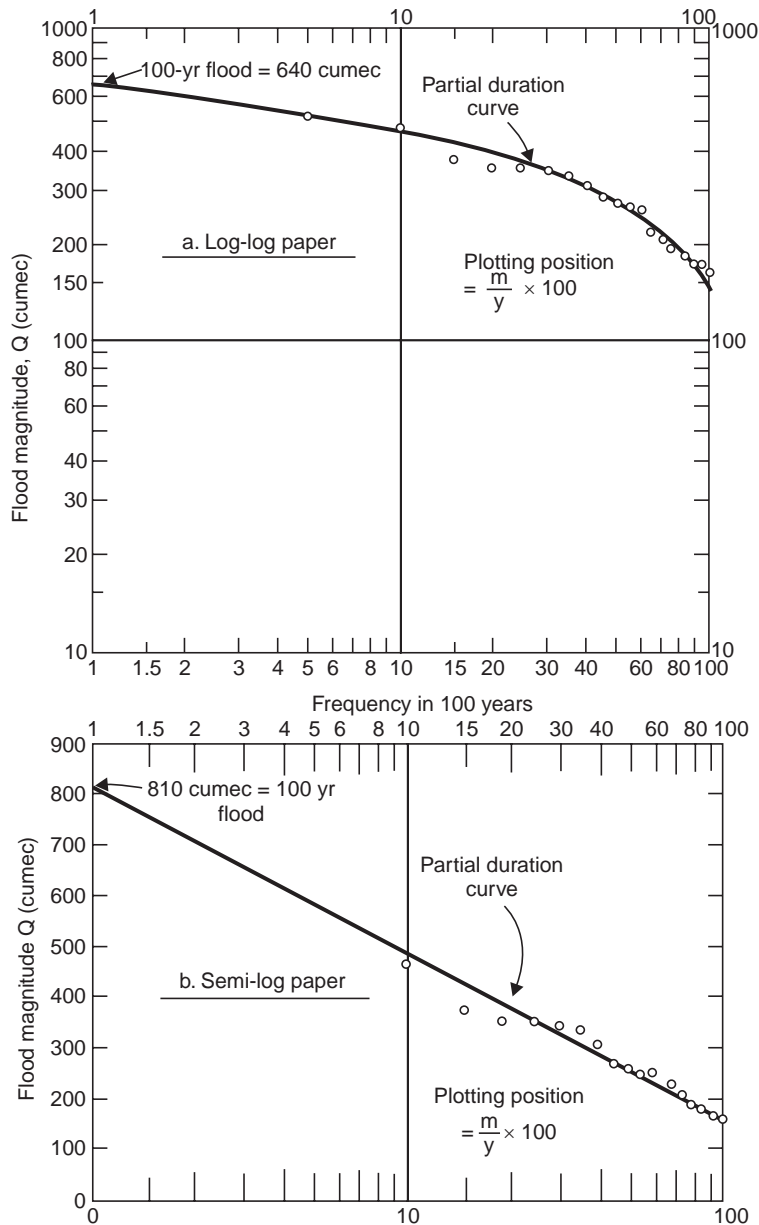

Fig. 8.5 Plots of partial duration curve (Example 8.6)

Events having a return period of less than 10 years ($P < 0.1$) based on annual series will occur more frequently than indicated because the second or third events in some years may be greater than the annual events in other years and have been omitted from consideration. If events that occur frequently ($P < 0.1$) are important, a partial duration series should be used. The partial duration series includes all events above a base that has been selected to include at least one event each year.

The partial duration series recurrence interval T_{PDS} is related to the annual series recurrence interval T as

$$T_{PDS} = \frac{1}{\ln T - \ln (T - 1)}$$

Langbein (1949) derived the theoretical relationship between T_{PDS} and T as given below. Though the relationship varies from region to region, it is significant only for recurrence up to 5 years and after that, a difference of 0.5.

| T_{PDS} | T |
|-----------|-------|
| 0.5 | 1.16 |
| 1.0 | 1.58 |
| 1.45 | 2.00 |
| 2.0 | 2.54 |
| 5.0 | 5.52 |
| 10.0 | 10.5 |
| 20.0 | 20.5 |
| 50.0 | 50.5 |
| 100.0 | 100.5 |

In partial duration series, since several occurrences in one year may be selected, the notion of annual occurrence (P_a) is introduced as

$$P_a = m/y$$

where m = number of occurrences in 'y' years and the probability P in 'per cent of time' is given by

$$P = (1 - e^{-P_a}) 100$$

and the average recurrence interval $T = 1/P_a$, and not $1/P$

In Example 8.6, a flood of 273 cumec has been exceeded 10 times during a period of 20 years. Then its

annual occurrence $P_a = m/y = 10/20 = 0.5$

average recurrence interval $T = 1/P_a = 1/0.5 = 2$ yr

annual probability $P = (1 - e^{-P_a}) 100 = (1 - e^{-0.5}) 100 = \mathbf{39.3\%}$.

Example 8.6 (a) *The highest annual floods for a river for 60 years were statistically analysed. The sixth largest flood was 30,000 cumec (30 tcm).*

Determine:

- (i) *The period in which the flood of 30 tcm may reoccur once*
- (ii) *The percentage chance that this flood may occur in any one year*
- (iii) *The percentage chance that this flood may not occur in the next 20 years*
- (iv) *The percentage chance that this flood may occur once or more in the next 20 years*
- (v) *The percentage chance that a 50-yr flood may occur (a) once in 50 years, (b) one or more times in 50 years*

Solution (i) Weibull; $T = \frac{n+1}{m} = \frac{60+1}{6} = 10.1$, say **10 yr**

(ii) Percentage chance, *i.e.*, $P = \frac{1}{T} \times 100 = \frac{1}{10.1} \times 100 = \mathbf{9.9 \text{ say } 10\%}$

(iii) Encounter probability,

$$P_{(N,0)} = (1-P)^N = \left(1 - \frac{1}{10.1}\right)^{20} = 0.124 \text{ or } \mathbf{12.4\%}$$

(iv) $P_{Ex} = 1 - (1-P)^N = 1 - P_{(N,0)} = 1 - 0.124 = 0.876$ or **87.6%**

(v) (a) $P = \frac{1}{T} \times 100 = \frac{1}{50} \times 100 = \mathbf{2\%}$

(b) $P_{(N,0)} = \left(1 - \frac{1}{50}\right)^{50} = 0.3631$

$$P_{Ex} = 1 - P_{(N,0)} = 1 - 0.3631 = 0.6369, \text{ say } \mathbf{64\%}$$

Example 8.6 (b) Determine the percentage chance that a 25-yr storm may occur

(a) In the next 10 years

(b) In the next year itself

(c) May not occur in another 15 years

Solution (a) $T = 25$, $P_{Ex} = 1 - (1-P)^N$, $P = \frac{1}{T}$

$$= 1 - \left(1 - \frac{1}{25}\right)^{10} = 0.335 \text{ or } \mathbf{33.5\%}$$

(b) $P_{Ex} = 1 - \left(1 - \frac{1}{25}\right)^1 = 0.04$ or **4%, i.e., 1 in 25 chance**

(c) $P_{(N,0)} = (1-P)^N = \left(1 - \frac{1}{25}\right)^{15} = 0.542$ or **54.2%**

Example 8.6 (c) Determine the return period (recurrence interval T) of a flood, which has a 10% risk of being flooded (a) in the next 100 years, (b) in the next 50 years.

Solution $P_{Ex} = 1 - (1-P)^N$, for risk of being exceeded

i.e., $P_{Ex} = 10\% = 0.1$

(a) $0.1 = 1 - (1-P)^{100}$, $(1-P)^{100} = 1 - 0.1 = 0.9$

$$1 - P = 0.9^{0.01} = 0.99895, \quad P = 0.00105 = 1.05 \times 10^{-3}$$

$$T = \frac{1}{P} = \frac{1}{1.05 \times 10^{-3}} = \mathbf{950 \text{ yr}}, \text{ say } 1000\text{-yr flood}$$

(b) $0.1 = 1 - (1-P)^{50}$, $(1-P)^{50} = 1 - 0.1 = 0.9$

$$1 - P = 0.9^{0.02} = 0.9979$$

$$P = 0.0021 = 2.1 \times 10^{-3}$$

$$T = \frac{1}{P} = \frac{1}{2.1 \times 10^{-3}} = \mathbf{476 \text{ Yr}}, \text{ say } 500\text{-yr flood.}$$

Note. If a structure has a life period of 50 years and if we can accept a 10% risk of its being flooded during its life, then we have to design the structure for a return period of T -Yr as follows:

$$P_{Ex} = 1 - (1-P)^{50}, \text{ for } 10\% \text{ risk, } P_{Ex} = 0.1$$

$$0.1 = 1 - (1-P)^{50}, \quad (1-P)^{50} = 1 - 0.1 = 0.9$$

$$(1-P) = (0.9)^{0.02} = 0.9979$$

$$\therefore P = 0.0021 = 2.1 \times 10^{-3}, \quad T = \frac{1}{P} = \frac{1}{2.1 \times 10^{-3}} = 476 \text{ yr}$$

i.e., we have to design the structure for a 476-yr flood and not for a 50-yr flood; if it is designed for a 50 yr flood, the risk of failure

$$P_{Ex} = 1 - (1 - P)^{50} = 1 - \left(1 - \frac{1}{50}\right)^{50} = 1 - 0.98^{50} = 0.6358 \text{ or } \mathbf{63.6\%}$$

Example 8.6 (d) *The maximum annual floods for the river Tapti at Ukai were statistically analysed for a period of 93 years (1876-1968). The mean annual flood and the standard deviation are 14210 and 9700 cumec, respectively.*

Determine:

(i) *The recurrence interval of the highest flood 42500 cumec (in 1968) by Weibull's method and what its percentage chance of occurring in (a) in any year, (b) in 10 years?*

(ii) *What is the recurrence interval of the design flood adopted by CWPC (49500 cumec) and the highest flood (42500 cumec) by Gumbel's method?*

Solution For the highest flood, its rank $m = 1$

$$(i) \text{ Weibull: } T = \frac{n+1}{m} \\ = \frac{93+1}{1} = \mathbf{94 \text{ yr}}$$

$$(a) \quad P = \frac{1}{T} = \frac{1}{94} = 0.01065 \text{ or } \mathbf{1.065\%}$$

i.e., its chance of occurrence in any year is $\simeq 1\%$

$$(b) P_{Ex} = 1 - (1 - P)^N = 1 - \left(1 - \frac{1}{94}\right)^{10} = 0.1014 \text{ or } \mathbf{10.14\%}, \text{ i.e., } 10\% \text{ chance.}$$

(ii) From Gumbel's Eqn. (8.17 a):

$$(a) \text{ Design flood } Q_{DF} = 49500 \text{ cumec} = Q_T, \quad \bar{Q} = 14210 \text{ cumec}$$

$$Q_T = \bar{Q} + \sigma (0.78 \ln T - 0.45), \quad \text{for } n > 50$$

$$49500 = 14210 + 9700 (0.78 \ln T - 0.45)$$

$$\ln T = 5.241, \quad T = 189, \text{ say } \mathbf{190 \text{ yr}}$$

against Weibull's 50 yr, Fig. 8.4

$$(b) \text{ Highest flood } Q_{MF} = 42500 \text{ cumec} = Q_T$$

$$42500 = 14210 + 9700 (0.78 \ln T - 0.45)$$

$$\ln T = 4.316, \quad T = \mathbf{75 \text{ yr}}, \text{ against Weibull's 30 yr, Fig. 8.4}$$

Gumbel Frequency Distribution: Resume of formulae:

For large values of n , ($n > 50$):

$$P = 1 - e^{-e^{-y}}, \quad T = \frac{1}{P} = \frac{1}{1 - e^{-e^{-y}}}$$

$$y_T = - \left[\ln \cdot \ln \frac{T}{T-1} \right] \quad \dots(8.14a)$$

$$y_T = - \left[0.834 + 2.303 \log \cdot \log \frac{T}{T-1} \right] \quad \dots(8.14b)$$

$$y = \frac{1}{0.78 \sigma} (X - \bar{X} + 0.45 \sigma), \quad y = y_T, X = Q \quad \dots(8.14)$$

or,
$$y = \frac{1.2825 (X - \bar{X})}{\sigma} + 0.577 \quad \dots(8.14c)$$

i.e.,
$$y = \frac{a(X - \bar{X})}{\sigma} + b, \quad a = 1.2825, b = 0.577 \quad \dots(8.14d)$$

$$X_T = \bar{X} + \sigma (0.78 y - 0.45) \quad \dots(8.17)$$

$$X_T = \bar{X} + \sigma (0.78 \ln T - 0.45) \quad \dots(8.17a)$$

$$X_T = \bar{X} + \sigma (1.8 \log T - 0.45). \quad \dots(8.17b)$$

Example 8.6 (e) Statistical analysis of the annual floods of the river Tapti (1876-1968) using Gumbel's method yielded the 100-yr and 10-yr floods as 42800 and 22700 cumec, respectively. Determine:

(a) the magnitude of a 20-yr flood.

(b) the probability of a flood of magnitude 35000 cumec (i) occurring in the next 10 years, (ii) in the next year itself.

Solution Eq. (8.14a): $y_{10} = -\ln \cdot \ln \frac{10}{9} = 2.25, \quad X_{10} = 22.7 \text{ tcm}$

$$y_{100} = -\ln \cdot \ln \frac{100}{99} = 4.6, \quad X_{100} = 42.8 \text{ tcm}$$

Eq. (8.14d): $2.25 = \frac{a(22.7 - \bar{X})}{\sigma} + b \quad \dots(i)$

$$4.6 = \frac{a(42.8 - \bar{X})}{\sigma} + b \quad \dots(ii)$$

(ii)–(i): $2.35 = 20.1 \frac{a}{\sigma} \quad \therefore \sigma = 20.1 \times \frac{1.2835}{2.35} = 10.969 \text{ tcm}$

From Eq. (8.14c): $22.7 - \bar{X} = (2.25 - 0.577) \frac{10.969}{1.2825} = 14.309$

$\therefore \bar{X} = 22.7 - 14.309 = 8.391 \text{ tcm}$

(a) Eq. (8.14a): $y_{20} = -\ln \cdot \ln \frac{20}{19} = 2.97$

Eq. (8.14c): $2.97 = \frac{1.2825}{10.969} (X_{20} - 8.391) + 0.577$

$$X_{20} = 28.856 \text{ tcm} \quad \text{or} \quad 28856 \text{ cumec}$$

Alternatively, Eq. (8.17a): $X_{20} = 8.391 + 10.969 (0.78 \ln 20 - 0.45) = 29 \text{ tcm}$, or **29000 cumec**

(b) Eq. (8.14c): $y_T = \frac{1.2825}{10.969} (35 - 8.391) + 0.577 = 3.6881$

Eq. (8.14a): $-\ln \cdot \ln \frac{T}{T-1} = 3.6881$

$$T = 41 \text{ yr}, \quad P = \frac{1}{T} = 0.0244$$

$$\text{Alternatively,} \quad P = 1 - e^{-e^{-y}} = 1 - e^{-e^{-3.6881}} = 1 - e^{-0.025} = 1 - 0.9753 = 0.0247$$

$$T = \frac{1}{P} = \frac{1}{0.0247} = 40.5, \text{ say } 40 \text{ yr}$$

$$(i) P_{Ex} = J_{(41, 10)} = 1 - (1 - 0.0244)^{10} = \mathbf{0.2188}, \text{ say } \mathbf{22\%}$$

$$(ii) P_{Ex} = J_{(41, 1)} = -(1 - 0.0244)^1 = 0.0244, \text{ or } \mathbf{2.44\%} \text{ chance}$$

Example 8.6 (f) The annual floods for a large period were statistically analysed by Gumbel's methods, which yielded $\bar{Q} = 19000$ cumec, $\sigma = 3200$ cumec.

Determine

(a) the probability of a flood magnitude of 30000 cumec occurring in the next year.

(b) the flood magnitude of 5-yr return period.

$$\text{Solution (a)} \quad y = \frac{1.2825}{3200} (30000 - 19000) + 0.577 = 5.5$$

$$P = 1 - e^{-e^{-y}} = 1 - e^{-0.0067} = 1 - 0.9901 = 0.0099 \simeq \mathbf{1\%}$$

$$P_{Ex} = 1 - (1 - 0.0099)^1 = 0.0099 \simeq \mathbf{1\%}$$

$$\text{(b)} \quad T = 5, \quad P = \frac{1}{5} = 1 - e^{-e^{-y}}, \quad y = 0.079$$

$$0.079 = \frac{1.2825}{3200} (X - 19000) + 0.577, \quad X = \mathbf{17758} \text{ cumec}$$

8.6 METHODS OF FLOOD CONTROL

A flood is an unusual high stage of a river overflowing its banks and inundating the marginal lands. This is due to severe storm of unusual meteorological combination, sometimes combined with melting of accumulated snow on the catchment. This may also be due to shifting of the course of the river, earthquake causing bank erosion, or blocking of river, or breaching of the river flood banks. Floods have swept vast regions in India, particularly in the basins of rivers Kosi, Brahmaputra, Godavari, Narmada and Tapti. Floods cause much loss of life and property, disruption of communication, damage to crops, famine, epidemic diseases and other indirect losses.

Design magnitudes of floods are needed for the design of spillways, reservoirs, bridge openings, drainage of cities and air ports, and construction of flood walls and levees (flood banks). The maximum flood that any structure can safely pass is called the 'design flood'.

The damages due to the devastating floods can be minimised by the following flood control measures, singly or in combination.

(i) by confining the flow between high banks by constructing levees (flood banks), dykes, or flood walls.

(ii) by channel improvement by cutting, straightening or deepening and following river training works.

(iii) by diversion of a portion of the flood through bypasses or flood ways. In some cases a fuse plug levee is provided. It is a low section of levee, which when once over topped, will

wash out rapidly and develop full discharge capacity into the flood-way. In other locations, a concrete sill, weir or spillway controlled by stop logs or needles may be provided so that the overflow occurs at a definite river stage. Sometimes dynamiting a section of levee is resorted to bypass the flood.

(iv) by providing a temporary storage of the peak floods by constructing upstream reservoirs and retarding basins (detention basins).

(v) by adopting soil conservation measures (land management) in the catchment area.

(vi) by temporary and permanent evacuation of the flood plain, and flood plain zoning by enacting legislation.

(vii) by flood proofing of specific properties by constructing a ring levee or flood wall around the property.

(viii) by setting up flood forecasting—short term, long term, rhythm signals and radar, and warning centres at vulnerable areas.

Flood Control by Reservoirs

The purpose of a flood control reservoir is to temporarily store a portion of the flood so that the flood peaks are flattened out. The reservoir may be ideally situated immediately upstream of the area to be protected and the water discharged in the channel downstream at its safe capacity (known from its stage-discharge curve), *i.e.*, the peak has been reduced by AB , Fig. 8.6. All the inflow into the reservoir in excess of the safe channel capacity is stored until the inflow drops below the channel capacity and the stored water is released to recover the storage capacity for the next flood.

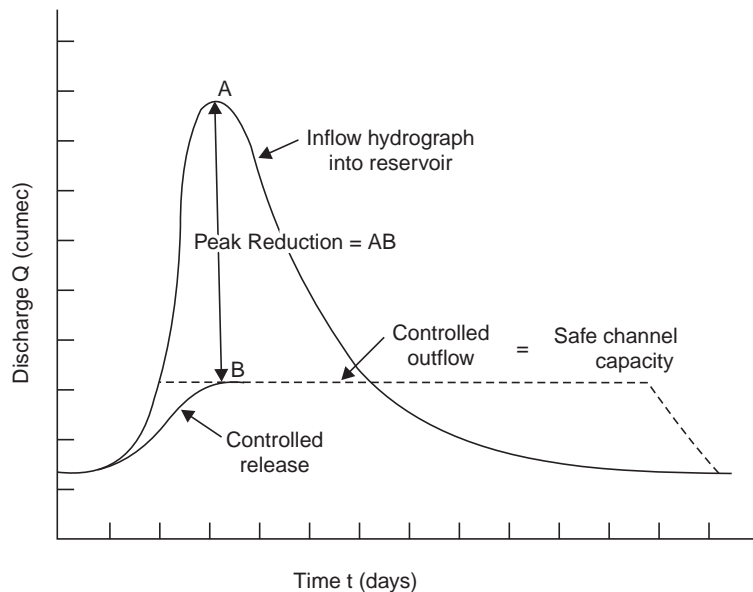

Fig. 8.6 Flood control by reservoirs

If there is some distance between the reservoir and the protected area but no local inflow between these points, the reservoir operation is similar to the above but the peak will

further be reduced due to storage in the reach downstream from the reservoir. If there is a substantial local inflow between the dam and the control point, the reservoir must be operated to produce a minimum peak at the protected area rather than at the dam site; otherwise the release from a reservoir may unfortunately synchronise at some point downstream with flood flows from a tributary. Timely and reliable weather forecasts and prompt information about precipitation upstream and downstream of the reservoir and the means of translation of this information into necessary flood hydrographs will all help in effective reservoir operation. Construction of reservoirs for flood control only is rarely economical and other benefits like irrigation, hydel power, also have to be taken into consideration. It is the modern practice to construct multipurpose reservoirs, where a space is allocated exclusively for flood control, usually above the spillway crest level and is made available when required by closing the spillway crest gates.

The effectiveness of the reservoir in reducing peak flows, increases as its storage capacity increases. The maximum capacity required is the difference in volume between the safe release from the reservoir and the maximum inflow. Since the hydrograph is wider at low flows, more water must be stored to reduce the peak by a given amount. As the peak reduction is increased, more marginal area will be protected from the floods. The benefits accrued by a unit peak reduction are usually less. Thus, the size of the reservoir has to be determined by weighing the cost involved in reducing the peak with the benefits accrued. A single reservoir across the main river may not give the required protection to all towns and cities widely located and reservoirs constructed across tributaries are effective in flood protection. In general, at least one-third of the total drainage area should come under one reservoir for effective flood control.

Retarding Basins

The release from a storage reservoir is controlled by gates and valves and regulated by the project engineer. A retarding basin is provided with outlets like a large spillway and sluices with no control gates. The sluice discharges like an orifice, *i.e.*, $Q = C_d A \sqrt{2gH}$, and there is a greater throttling of flow when the reservoir is nearly full than would a spillway discharging like a weir, *i.e.*, $Q = CLh^{3/2}$ (Fig. 8.7). However, a spillway is necessary for emergency in case of the flood exceeding the design maximum.

The discharge capacity of a retarding basin when full should equal the safe discharging capacity of the channel downstream. The storage capacity of the basin should be equal to the volume of the design flood minus the volume of water released during the flood. A retarding basin is used only for the purpose of flood control. After the peak of flood has passed, the inflow will gradually become equal to the outflow. One of the limitations of the retarding basins is that the discharge from the basin may synchronise with the flood flow of a tributary downstream and as such they are constructed on comparatively small stream while storage reservoirs are provided across big rivers (since the release can be regulated).

For any pool elevation of the reservoir, the storage and discharge can be calculated. For a known inflow hydrograph, the corresponding outflow hydrograph can be determined by any method of flood routing (Chapter 9).

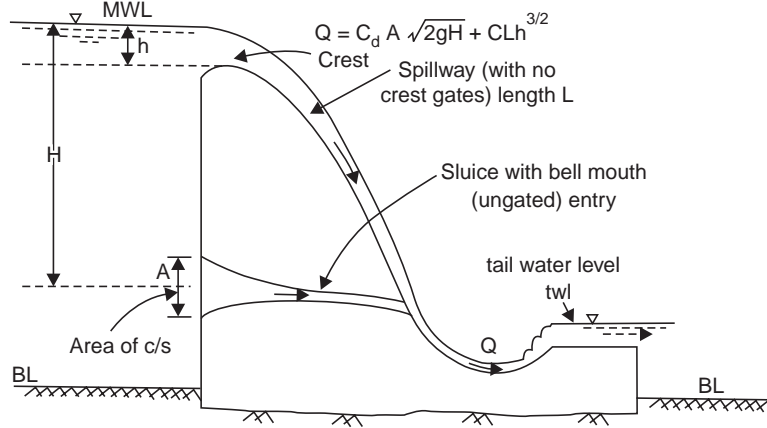

Fig. 8.7 Retarding basin

Construction of Levees

The construction of levees (flood banks or dykes) is extensively followed in India, since it is an economical, direct and immediate method. The design and construction of levees are similar to those of an earth dam. The levees are constructed beyond the meander belt of a river, Fig. 8.8 (a) and they tame a river not to change its course. As far as possible, there should be very few curves in their alignment. They require constant watch and after the floods recede, repairs and restoration of levees should be resorted to.

The spacing and height of levees are determined by a series of trials. A height is assumed and the discharge through the proper channel is computed for the assumed high water flow, which is the level of the top of bank less the free board. This flow subtracted from the estimated probable maximum flood discharge gives the discharge to be passed over the flood ways between the proper channel and the levees (Figs. 8.8 (a) and (b), 8.9 and 8.10). Area of the flood ways is then obtained by dividing it by the velocity of flow. The spacing of levees thus obtained, should give a minimum value for the cost of levees and the value of the submerged land in the flood way. The effects of levees on flood flow are:

- (i) increase in the rate of flood flow
- (ii) increase in the flood water elevation
- (iii) increase in the carrying capacity of the channel
- (iv) increase in the scouring action
- (v) decrease of surface slope of stream above the leveed section

Channel Improvement

Channel improvement increases the discharging capacity of the stream thereby decreasing the height and duration of the flood. Flood carrying capacity can be increased either by increasing the cross-sectional area or by increasing the velocity along the river. Enlarging the section is attempted only for narrow and shallow channels with small watersheds, the limit of such enlargement in width being 30-40 m. Deepening is preferred to widening since the hydraulic mean radius increases more with depth (for the same increase in the sectional area) thus increasing the velocity.

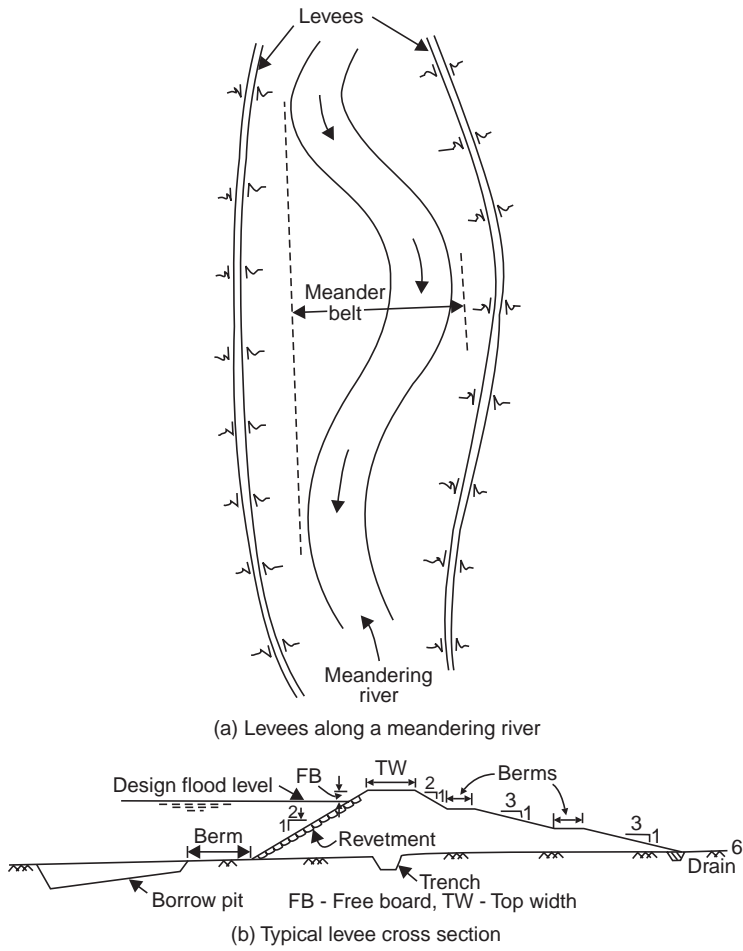

Fig. 8.8 Flood control by levees

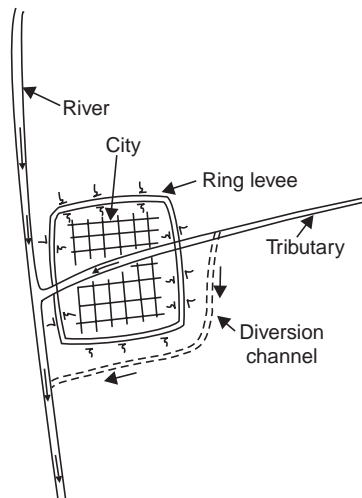

Fig. 8.9 Ring levee to protect a city

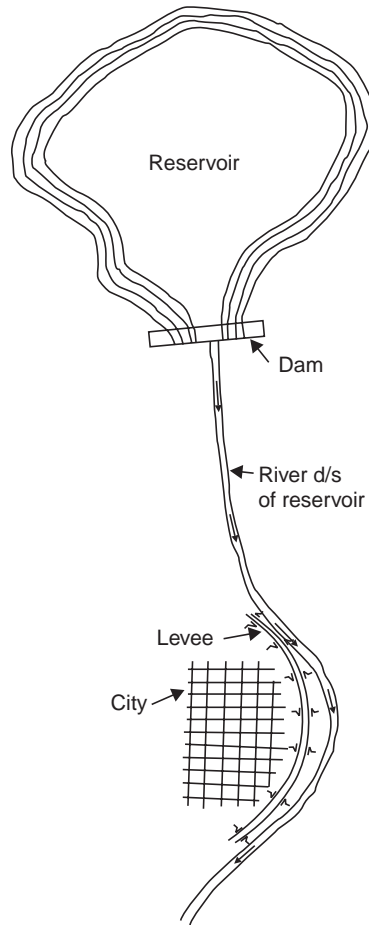

Fig. 8.10 Flood protection by reservoir and levees for a city

The channel velocity (given by Manning's or Chezy's formulae) is affected by hydraulic mean radius, slope of river bed and roughness of the bed and sides. Roughness can be reduced by

- (i) removing sand bars.
- (ii) prevention of cropping on river beds near banks.
- (iii) removal of fallen trees and other snags.
- (iv) elimination of sharp bends of meanders by providing cutoffs (Fig. 8.11).

In a stream, deepening results in the loss of slope as its outlet can not usually be lowered. Deepening can be resorted to only when cutoffs are provided, when the slope of the channel is increased due to the reduction in the length of flow. Thus, a cutoff helps

- (i) in increase the velocity by increasing the slope,
- (ii) to shorten the path of flow by elimination of meanders, and consequently
- (iii) to shorten the levees necessary to confine flood waters.

Elimination of meanders by providing straight cutoffs has been done on the river Mississippi in USA.

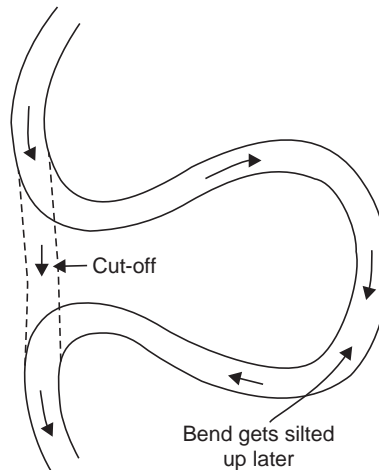

Fig. 8.11 Cut-off in a meandering river

Example 8.7 A channel has a bottom width of 200 m, depth 6 m and side slopes 1:1. If the depth is increased to 9 m by dredging, determine the percentage increase in velocity of flow in the channel. For the same increase in cross sectional area, if the channel is widened (instead of deepening), what is the percentage increase in the velocity of flow.

Solution Chezy's formula, $V = C\sqrt{RS}$

where V = velocity of flow in the channel

R = hydraulic mean radius

S = bed slope of the channel

C = a constant, depending on the roughness of the bed and sides

Assuming the bed slope and roughness are the same in both the cases of deepening and widening, $V \propto \sqrt{R}$

Case (i) Increasing the depth to 9 m by dredging.

Putting the subscript 'o' for the original area of cross section (A), wetted perimeter (P) and the hydraulic mean radius (R), i.e., before deepening Fig 8.12,

$$A_0 = (200 + 1 \times 6)6 = 1236 \text{ m}^2$$

$$P_0 = 200 + 2 \times 6 \sqrt{1^2 + 1} = 217 \text{ m}$$

$$R_0 = \frac{A_0}{P_0} = \frac{1236}{217} = 5.7 \text{ m}$$

After deepening from 6 m to 9 m, Fig. 8.12,

$$A = (194 + 1 \times 9)9 = 1827 \text{ m}^2$$

$$P = 194 + 2 \times 9 \sqrt{1^2 + 1} = 219.4 \text{ m}$$

$$R = \frac{A}{P} = \frac{1827}{219.4} = 8.33 \text{ m}$$

$$\text{Velocity increase by deepening} = \frac{\sqrt{8.33} - \sqrt{5.70}}{\sqrt{5.7}} \times 100 = 21\%$$

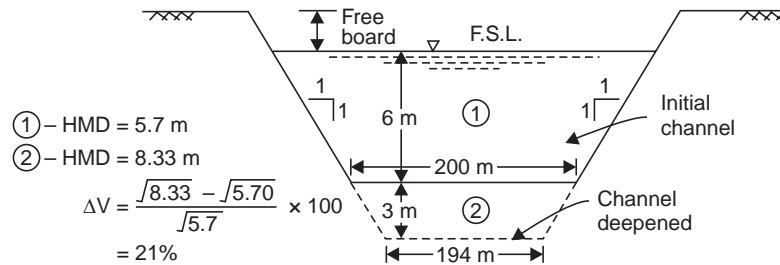

Fig. 8.12 Channel improvement by deepening (Example 8.7)

Case (ii) For the same increase in the cross sectional area, widening the channel, Let the bottom width after widening be b' .

$$1827 = (b' + 1 \times 6)6$$

$$\therefore b' = 298.5 \text{ m}$$

$$\text{After widening } P = 298.5 + 2 \times 6 \sqrt{1^2 + 1} = 315.42 \text{ m}$$

$$R = \frac{A}{P} = \frac{1827}{315.42} = 5.8 \text{ m}$$

$$\text{Velocity increase on widening} = \frac{\sqrt{5.8} - \sqrt{5.7}}{\sqrt{5.7}} \times 100 = 0.84\%$$

Thus, the velocity increase will be only 0.84% on widening as against 21% by deepening. Hence, exploding the river channels at the mouths at the start and ebbing of floods will be logical proposition.

Silting of river-channels at mouths—It has been found that the rate of increase in the HFL is faster than the rate of increase in HFQ due to silt deposits at the mouths of river channels. Rate of silting on an average on the banks of Narmada (central India) is approximately 35 cm per year, with 60 cm in 1968 floods. Natural consolidation of silt deposits does not facilitate conversion to suspended silts at times of flood. However, if the river bed is exploded at the time of recession of floods, the silt deposits are likely to be transported into the sea.

8.7 SOIL CONSERVATION MEASURES

The best way to prevent silt deposition is to arrest silt at the place of its origin, *i.e.*, by undertaking soil conservation measures in the catchment area. Soil conservation measures for the entire catchment like contour bunds, check dams, terraces, gully plugging, vegetative cover (strip cropping), afforestation, land management, stream bank protection, etc. Fig. 8.13 to 8.18 are very necessary to retard the velocity of runoff, to control soil erosion, to absorb more water in the soil and to protect the dams and reservoirs from being silted up. For example, a change in land use by surface vegetation increases the infiltration capacity and reduces surface runoff. Soil conservation is a subject of its own and Fig. 8.13-8.18 given here illustrate only the principle, and the reader may refer to standard works on the subject. The choice of the management practices should be based on information of the hydrologic cycle of the watershed. A coordinated effort by engineers, agronomists, foresters, geologists, hydrologists and economists would be very desirable.

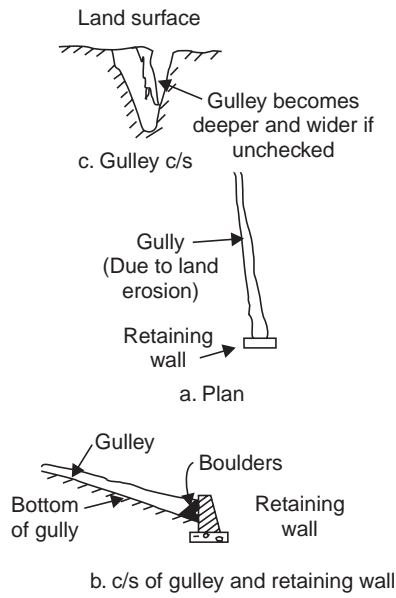

Fig. 8.13 Gully plugging

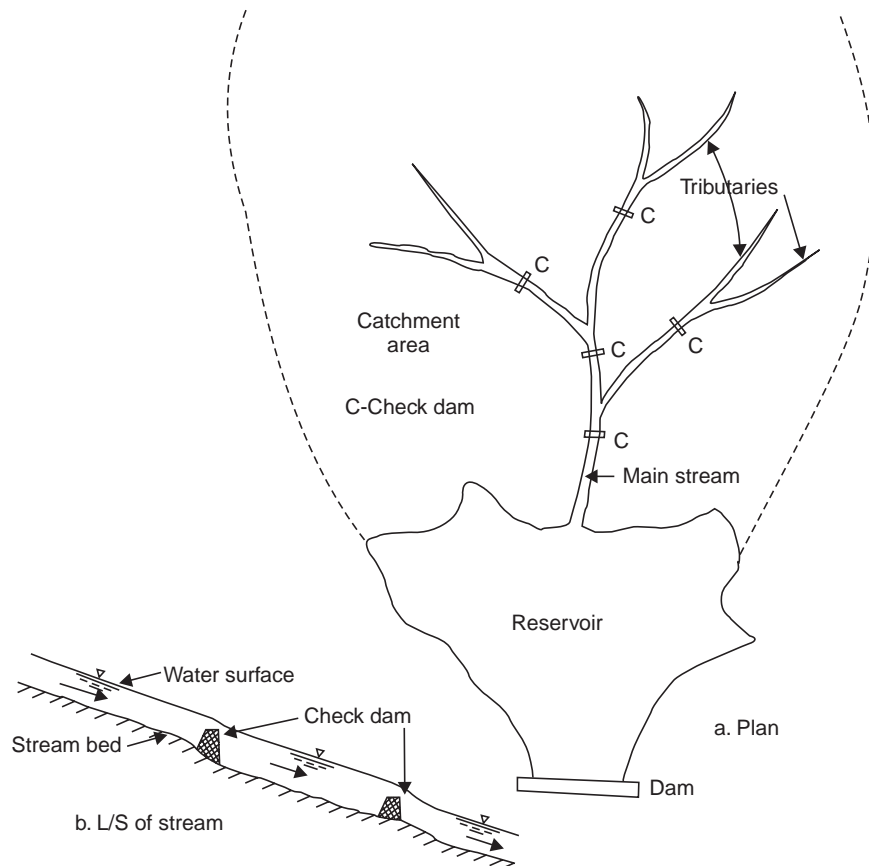

Fig. 8.14 Check dams

Flood plain zoning Areas, very near to the river are the most vulnerable and therefore should not be allowed to be used for building houses. They may be used for parks, recreation grounds, etc. so that inundation of such land may not result in loss of human lives or any significant damage to property. Raising place for habitations above flood heights can be viewed as an adjunct to embankments.

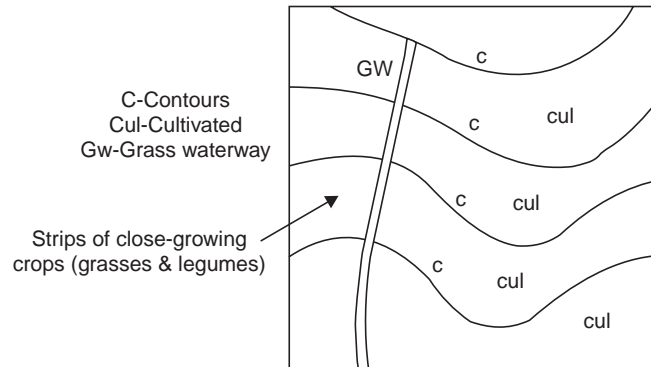

Fig. 8.15 Contour farming

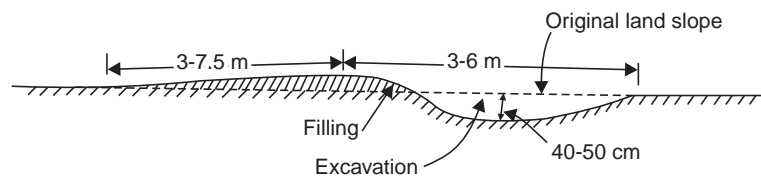

Fig. 8.16 Contour terrace

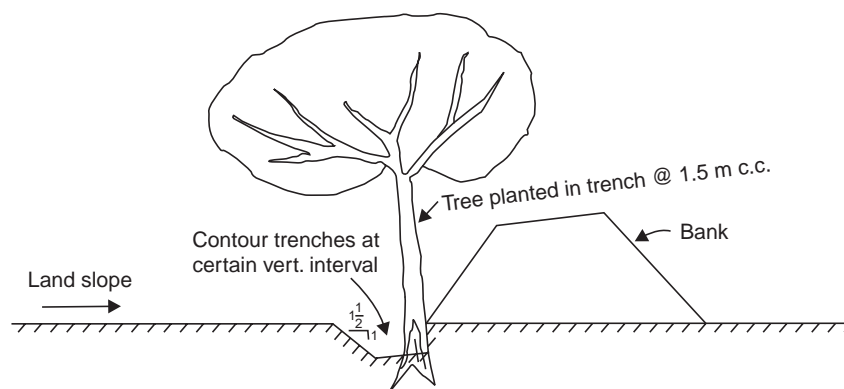

Fig. 8.17 Contour trenching

8.8 FLOOD CONTROL ECONOMICS

In a flood control project, the degree of flood protection (*i.e.*, to the required stage) should be justified by an economical analysis of the costs involved in raising the structure to the required heights (say, the height of spillway) and the direct and indirect benefits obtained by flood

protection up to that stage. Generally, the flood stage for which the ratio annual benefits to cost is a maximum is adopted for the design of the flood protection works (Fig. 8.19). Protection against floods of rare occurrence is uneconomical because of the large investment (for a small increase in the benefits) and hence there is always a certain amount of flood risk involved.

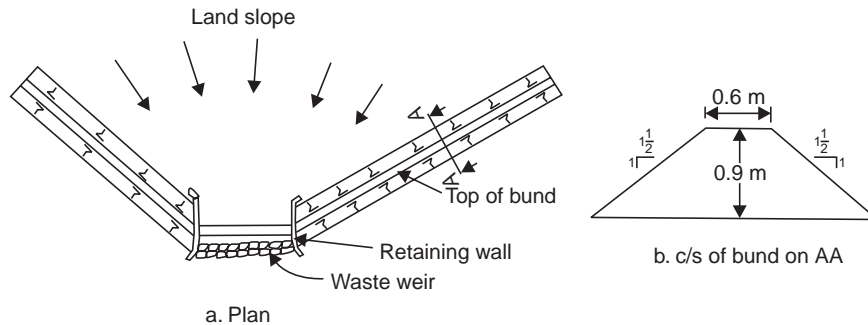

Fig. 8.18 Contour bund

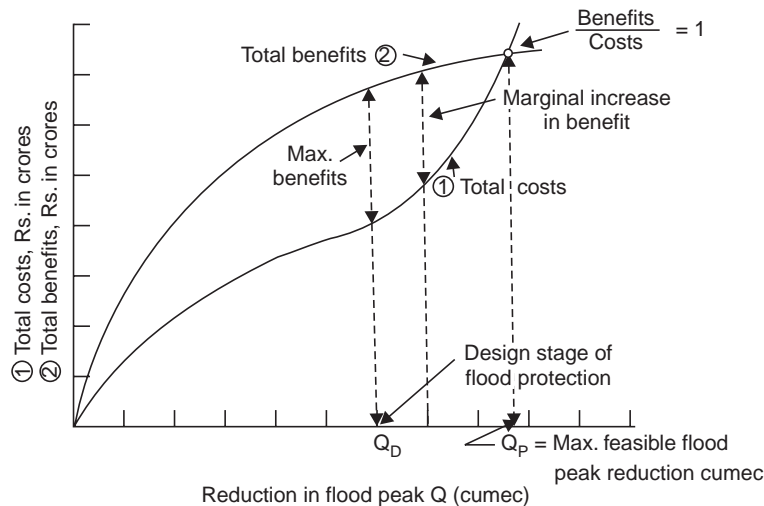

Fig. 8.19 Cost-benefit analysis for design stage of flood protection

The flood control costs include:

- (i) Capital costs involved in the construction of the structure to the required flood height (i.e., to offer the required degree of flood protection, say, by a combination of dam-spillway, levees and channel improvement)
- (ii) Interest cost on capital expenditure
- (iii) Sinking fund, depreciation and taxes
- (iv) Operational expenses and maintenance cost

The benefits of flood control include

- (i) Direct or primary benefits accruing from prevention of flood damages to structures downstream, losses arising from disruption of communication, (and business), loss of life and property, damage to crops, etc.

(ii) Indirect benefits resulting from the money saved under insurance and Workmen's compensation laws, higher yields from intensive cultivation of protected lands and reduction in flood-prone epidemic diseases, etc.

Assessment of potential flood damage is an important requirement in any organised flood control programme. Generally stage-damage curves are plotted to show that damage in a particular region in relation to the rising flood stages in that reach. Indirect damage by floods deals with the loss of business and services to community. This is a socioeconomic loss and is difficult to assess because of the various economic and physical factors involved whereas the direct damages can be estimated in terms of money value. An assessment of the damages caused by floods can be made when the data is collected and presented in the following form:

- (i) Area affected (km²)
- (ii) Population affected (lakhs)
- (iii) Crops affected
 - (a) in hectares
 - (b) value in rupees
- (iv) Damage to property
 - (a) number of houses damaged
 - (b) cost of replacing or repairing in rupees
- (v) Loss of livestock
 - (a) category number
 - (b) value in rupees
- (vi) Human lives lost
- (vii) Damage to public works in rupees

Suitable flood indices have to be developed from year to year to enable comparison to be made of the various flood damages.

Combination of Flood Control Measures

The object of a flood-control study is to decide which of the flood control measures, singly or in combination, are most suited and their location, size, design and costs. The design of flood control works should be closely related to the hydrological features and economic justification of the project.

Suppose the flood control project involves the construction of a reservoir, levees and channel improvement works, the factors governing the final selection of various combinations are illustrated in Fig. 8.20. The cost of construction of reservoir to reduce the design flood to various lower peaks is indicated by curve (1). The cost of construction of levees and other channel improvement works for protection against various flood peaks is indicated by curve (2). The sum of the ordinates of the two curves indicates the combined cost of flood protection by reservoirs, levees and channel improvement works and is given by the curve (3). The minimum point *P* of the combined cost curve represents the most economic combination. The reduced flood peak and the total cost of works can be read off at this point.

See also Appendix-C: Reservoir Design Studies.

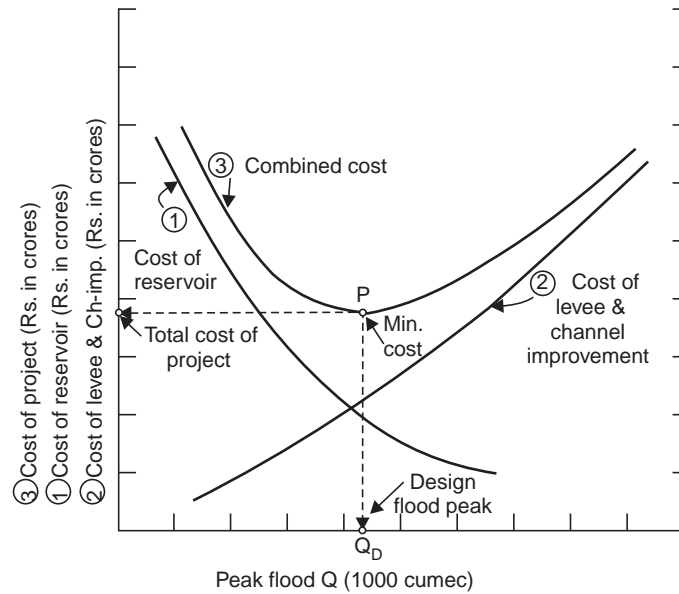

Fig. 8.20 Cost analysis for combination of flood control measures

Example 8.8 The costs of construction of levees for flood protection for various flood peaks are given below. From this and other data given, make an economic analysis of the flood control project and determine the flood peak for which the levees have to be designed.

| Flood peak (1000 cumec) | Total damage under the flood peak (Rs. in crores) | Recurrence interval of flood peak (yr) | Annual project cost up to the flood peak (Rs. in crores) |
|----------------------------|--|--|---|
| 10 | 0 | 2 | 0.2 |
| 15 | 2 | 10 | 0.4 |
| 20 | 5 | 20 | 0.6 |
| 25 | 8 | 30 | 0.8 |
| 30 | 12 | 42 | 1.0 |
| 35 | 20 | 60 | 1.3 |
| 40 | 32 | 80 | 1.6 |
| 50 | 46 | 150 | 1.8 |
| 60 | 70 | 300 | 2.0 |
| 70 | 98 | 600 | 2.4 |

Solution The economic analysis is made as shown in Table 8.5 on the basis of benefit-cost ratio.

The ratio of benefit to cost is a maximum of 1.39 when the levees are constructed to safely pass a flood peak of 40000 cumec (Fig. 8.21). Hence, the levees designed for this flood peak will be most economical.

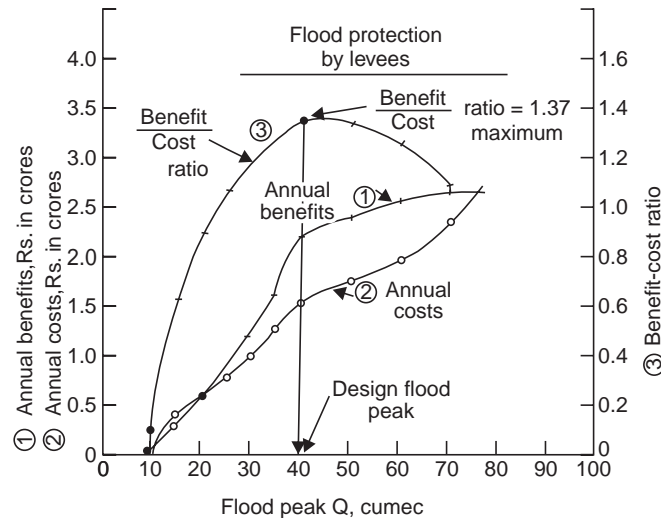

Fig. 8.21 Benefit-cost analysis (Example 8.8)

8.9 FLOOD FORECASTING AND WARNING

The flood forecasts are issued on the basis of the analysis of weather charts and indicate the likelihood of heavy rainfall over the specified areas with the next 24 to 48 hours. All India forecasts are prepared every day at Poona.

Radar is very effective in the detection and tracking of severe storms. Meteorological satellites give an excellent idea of the cloud cover over the whole of India and neighbouring countries.

After the formulation of forecast, it must be disseminated amongst persons concerned at the fastest speed. This can be done by utilising all available media of communications like telegraph, teleprinter, telephone and wireless and organising a hierarchy for onward transmission, if necessary.

One of the methods of forecasts in The Bureau of Meteorology, Australia comprises the following procedural steps:

- (i) Collection of previous 24-hour rainfall in respect of each catchment
- (ii) Updating the Anticident Moisture Index
- (iii) Working out the average depth of rainfall
- (iv) Assessment of likely extent of the rain from weather charts
- (v) Collection of river stages
- (vi) Issue of preliminary warnings with all factual data collected at every 6-hour interval; the final advice is issued using the crest relationship.

A schematic diagram of the flood forecasting and warning system contemplated for the Tapti basin (central India) is given in Chart 8.1.

Table 8.9 Economic analysis of flood control—by constructing levees (Example 8.8)

| <i>Flood peak (1000 cumec)</i> | <i>Total damage for the peak (Rs. crores)</i> | <i>Increment of damage (Rs. crores)</i> | <i>Recurrence interval of flood peak (Yr)</i> | <i>Increment in recurrence interval (Yr)</i> | <i>Annual benefit from protec- tion of incre- mental damage Rs. crores (3) ÷ (5)</i> | <i>Total annual benefits from protection for flood peak (Rs. crores)</i> | <i>Annual project cost for the flood peak (Rs. crores)</i> | <i>Ratio of benefit to cost (7) ÷ (8)</i> |
|------------------------------------|---|---|---|--|--|--|--|---|
| 1 | 2 | 3 | 4 | 5 | 6 | 7 | 8 | 9 |
| 10 | 0 | | 2 | | | 0 | 0.2 | 0 |
| 15 | 2 | 2 | 10 | 8 | 0.25 | 0.25 | 0.4 | 0.62 |
| 20 | 5 | 3 | 20 | 10 | 0.30 | 0.55 | 0.6 | 0.92 |
| 25 | 8 | 3 | 30 | 10 | 0.30 | 0.85 | 0.8 | 1.06 |
| 30 | 12 | 4 | 42 | 12 | 0.33 | 1.18 | 1.0 | 1.18 |
| 35 | 20 | 8 | 60 | 18 | 0.44 | 1.62 | 1.3 | 1.25 |
| 40 | 32 | 12 | 80 | 20 | 0.60 | 2.22 | 1.6 | 1.39 |
| 50 | 46 | 14 | 150 | 70 | 0.20 | 2.42 | 1.8 | 1.34 |
| 60 | 70 | 24 | 300 | 150 | 0.16 | 2.58 | 2.0 | 1.29 |
| 70 | 98 | 28 | 600 | 300 | 0.09 | 2.67 | 2.4 | 1.10 |

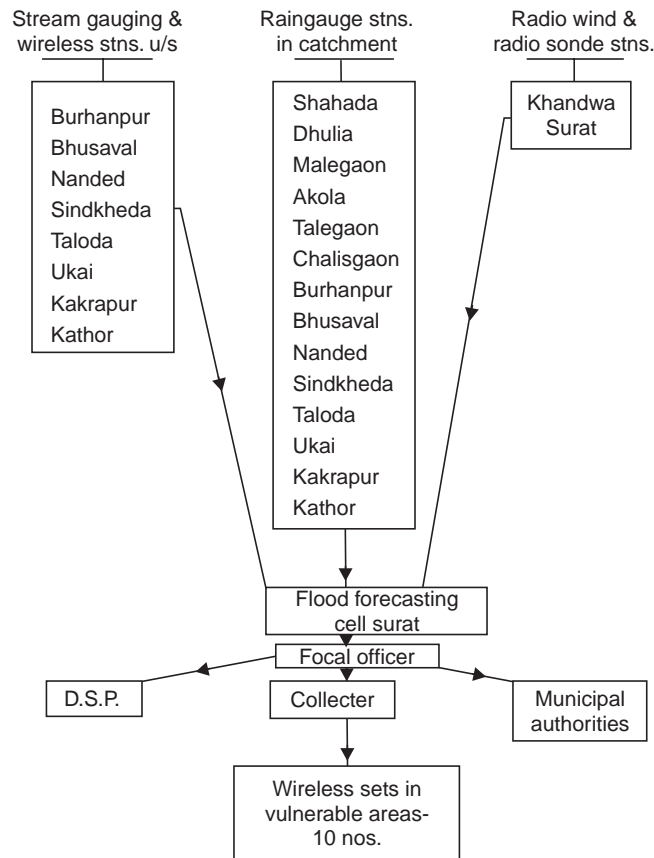

Chart 8.1 Flood forecasting system in Tapti basin (after B.S. Rao, 1969)

The flood warning system basically means the working out of the flood hydrograph at a given point sufficiently in advance, given the flood hydrograph of some gauge or gauges sufficiently upstream, taking into consideration.

- (i) the effect of the incidence of rainfall forecast for or that has fallen in the intervening catchment and the consequent contribution of floods enroute, and
- (ii) the moderation affected by the valley storage from the upstream gauge to the point under consideration.

The flood warning system is prepared by

- (i) forecasting crest height and time.
- (ii) flood routing techniques.

With a properly developed system of scientific flood forecasting and warning, human toll and destruction to movable properties could be greatly mitigated.

Summary—The various steps involved in the design of a flood control project are:

- (i) Determination of the project design flood and flood characteristics of the basin.
- (ii) Assessment of flood damages for different flood stages and socio-economic problems involved.
- (iii) Field survey of flood-prone areas and defining areas to be protected.

- (iv) Determination of the possible methods of flood protection.
- (v) If flood control is feasible by construction of reservoirs and levees, selection of suitable sites and their physical characteristics.
- (vi) Design details of the flood control structures proposed and preparation of cost estimates.
- (vii) For a combination of flood control measures, selection of a flood peak that offers the desired protection at minimum cost.
- (viii) Making the cost-benefit analysis of the project and its economic justification.
- (ix) Development of a scientific flood forecasting and warning system.
- (x) Preparation of a detailed project report, indicating the alternative flood control measures explored, the combination finally selected with the economic justification for the same, and the degree of flood protection offered.
- (xi) Construction of the project proposed after approval and sanction of the budget from the authority concerned.

QUIZ VIII

I Match the items in 'A' with the items in 'B' (more than one item may fit in 'B')

- | A | B |
|----------------------------------|---|
| (i) Floods | (a) South India |
| (ii) SPF | (b) Central India |
| (iii) Design storm | (c) Maharashtra State |
| (iv) Maximum flood discharge | (d) U.S.A. |
| (v) Ryves formula | (e) Flood frequency as a factor in flood-estimation |
| (vi) Dicken's formula | (f) Flood control |
| (vii) Inglis formula | (g) Construction of a cofferdam |
| (viii) Fuller's formula | (h) \approx twice coefficient of variation ($2C_v$) |
| (ix) Creager's formula | (i) Increase HMD by deepening |
| (x) Annual flood series | (j) Rational formula |
| (xi) Partial duration series | (k) Moisture adjustment |
| (xii) Coefficient of skew, C_s | (l) Spillway design flood |
| (xiii) Retarding basins | (m) High intensity of rainfall |
| (xiv) Channel improvement | (n) 80% of MPF |

II Say 'True' or 'False'; if false, give the correct statement:

- (i) Floods are caused by succession of high intensity storms on a basin.
- (ii) The design flood is taken as the maximum probable flood that may occur on a basin.
- (iii) The maximum probable flood includes the extremely rare and catastrophic floods and is usually considered for the spillway design of very high dams.
- (iv) The standard project flood is a fare estimate of the flood resulting from the most severe combination of meteorological and hydrological conditions of the basin.
- (v) The PMP is derived from the most critical combination of storms and moisture adjustment which, after minimising losses, when applied on the design unit hydrograph for the basin, will produce the MPF.

- (vi) The MPF for a basin is usually around 80% of the SPF.
- (vii) In flood control project, 100% flood protection is provided and hence there is absolutely no flood risk.
- (viii) In a partial duration series, there may be 2–3 high floods of the same year and does not give a true distribution series.
- (ix) Annual series are useful during the construction period of a large dam project, while the partial duration series are preferred for the spillway design flood.
- (x) The critical (design) intensity of rainfall occurs when the duration of storm is more than the concentration time.
- (xi) When enough storm data for a basin is not available, the PMP is estimated by storm transposition from a neighbouring catchment which is meteorologically homogeneous.
- (xii) The Gumbel distribution provides a satisfactory fit for partial duration floods or rainfall data.
- (xiii) While the annual floods are plotted against their probability of their occurrence in 100 years, the partial duration floods are plotted against percentage of time.
- (xiv) In channel improvement (for flood control), widening is preferred to deepening.
- (xv) While Radar gives an excellent idea of cloud cover, the meteorological satellites are very effective in the detection and tracking of severe storms.
- (xvi) A flood forecasting and warning system basically means working out of the flood hydrograph at a given point sufficiently in advance, given the flood hydrographs at sufficiently upstream point/s.
- (xvii) The design flood is usually selected after making a cost-benefit analysis.
- (xviii) Land management is ineffective in flood control.
- (xix) If a certain flood occurs once in 50 years, then its chance of occurring in any one year is 2%.
- (xx) Generally, the flood stage (flood peak) for which the ratio of annual benefits to cost is a maximum is adopted for the design of flood protection works.
- (xxi) The 100-yr flood will be equalled or exceeded 10 times in a 1000 year period.
- (xxii) Protection against rare floods is uneconomical and hence there is always a certain amount of flood risk involved.
- (xxiii) The first to suggest that frequency should be considered as a factor in estimating flood was:
 - (a) Allen Hazen
 - (b) Gumbel
 - (c) Fuller
 - (d) Weibull

(false: *ii, vi, vii, ix, x, xii, xiii, xiv, xv, xviii*)

III Classify the following into tangible (direct) and intangible (indirect) benefits due to flood control.

- (i) Prevention of damage to structures
- (ii) Loss of life and property
- (iii) Money saved under insurance and Workmen's Compensation Laws
- (iv) Higher yields from intensive cultivation of protected lands
- (v) Elimination of losses arising from interruption of business (due to disruption of communication)
- (vi) Reduction in flood-prone epidemic diseases
- (vii) Damage to crops.

IV Choose the correct statement/s in the following:

- 1 The methods of estimating high flood discharge are
 - (i) by applying PMP on the design unit hydrograph for the basin.

- (ii) By empirical formulae developed for the regions.
 - (iii) By applying rational formula.
 - (iv) By flood frequency studies.
 - (v) By stochastic methods.
 - (vi) From the percent flood risk that can be allowed in the project.
 - (vii) All the above methods.
- 2 The methods of mitigating floods are
- (i) by construction of reservoirs across tributaries
 - (ii) by construction of a large reservoir across the main stream
 - (iii) by construction of a retarding basin across a large river with a tributary joining the river downstream
 - (iv) by construction of levees, flood banks and dykes
 - (v) by channel improvement
 - (vi) by land management
 - (vii) by temporary evacuation of low lying areas and flood warnings
 - (viii) all the above methods.
- 3 The 'design flood' is taken as
- (i) flood peak derived by applying PMP on the design unit hydrograph
 - (ii) 80% (approx.) of MPF
 - (iii) SPF
 - (iv) the flood of the recurrence interval corresponding to the percent risk that can be allowed in the project
 - (v) the flood stage for which the ratio of benefit to cost is maximum
 - (vi) the 25-year flood for a land drainage project
 - (vii) the 160-year flood for a spillway design or bridge
 - (viii) all the above.
- (1—except *vi*, 2—*i*, *iv*, *v*, *vi*, *vii*; 3 *vii*).

QUESTIONS

- 1 (a) Explain 'design flood'. Is this the same as 'maximum probable flood' ?
- (b) What are the methods of estimating maximum flood discharge? Give three formulae for maximum flood estimation in India indicating for which part of the country they are applicable.
- (c) Find the value of the constants C and n in the empirical formula $Q = CA^{n*}$, where Q is the flood discharge in cumec and A is the catchment area in km^2 from the following data:
- | | | | | | |
|------------------------|-----|-----|-----|-----|-----|
| A (km^2): | 4 | 10 | 50 | 100 | 200 |
| Q (cumec): | 100 | 158 | 354 | 500 | 706 |
- (Hint Plot Q vs. A on log-log paper; $C = 50$ —intercept; $n = 0.5$ slope of straight line;
 $Q = 50\sqrt{A}$)
- 2 The design storm for a basin has the depth of rainfall for successive hours as 5.6, 7.6 and 5.2 cm. The 1-hr design unit hydrograph for the basin may be approximated by a triangle of base 6 hours with a peak of 60 cumec occurring at the 2nd hour from the beginning. Compute the flood hydrograph assuming an average loss rate of 0.5 cm/hr. Base flow may be neglected.

- 3 (a) Explain the following terms with reference to frequency studies:
 (i) Annual series (ii) Partial duration series
 (iii) Recurrence interval
- (b) At a particular gauging station, the annual maximum floods are recorded from 1951 to 1975. The mean and standard deviation of these floods are 310.24 cumec and 110.54 cumec, respectively. Assuming that the flood series follow Gumbel's distribution, determine the flood magnitudes for the recurrence intervals of 200, 100, 50 and 25 years. Plot these points on the Gumbel's probability paper.
- 4 (a) Differentiate: deterministic, probabilistic and stochastic processes in estimation of maximum annual rainfall or flood.
 (b) Records of peak flow are available for a river at a station where a reservoir is to be constructed for a period of 75 years. The arithmetic mean of the peaks is 8200 cumec and the standard deviation is 3170. Making use of Gumbel's method determine the recurrence interval for a flood of 18400 cumec.
- 5 (a) Define 'Recurrence interval' and 'Frequency' as applied to annual floods or rainfall.
 (b) What should be the recurrence interval of a flood such that the probability of its occurrence in a 10-year period is 0.01?
 (c) The mean of the annual maximum floods at a gauging station with 40 years of records is 1300 cumec and the variance is 1620 cumec. Estimate the magnitude of the 100-year flood.
 (**Hint:** variance = square of standard deviation, σ^2)
- 6 The annual flood peaks for Nagavalli river at Thottapalli are given for the period 1930-1950.
 (i) Plot the recurrence interval versus flood peak
 (ii) From the plot, determine the magnitudes of 50-yr and 100-yr floods.
 (iii) What is the recurrence interval of a flood magnitude of 300 cumec?

| <i>Year</i> | <i>Flood (cumec)</i> | <i>Year</i> | <i>Flood (cumec)</i> |
|-------------|----------------------|-------------|----------------------|
| 1930 | 1065 | 1941 | 910 |
| 31 | 645 | 42 | 750 |
| 32 | 1005 | 43 | 930 |
| 33 | 1350 | 44 | 750 |
| 34 | 860 | 45 | 1070 |
| 35 | 150 | 46 | 830 |
| 36 | 2260 | 47 | 1095 |
| 37 | 650 | 48 | 384 |
| 38 | 2840 | 49 | 2230 |
| 39 | 990 | 1950 | 3210 |
| 1940 | 870 | | |

- 7 The maximum annual floods for a river for 26 years are given below:
 (i) Plot the frequency curve.
 (ii) Determine the magnitude of a 100-yr, 50-yr and 20-yr floods.
 (iii) What is the recurrence interval of a flood of 300 cumec?

| <i>Year</i> | <i>Flood (cumec)</i> | <i>Year</i> | <i>Flood (cumec)</i> |
|-------------|----------------------|-------------|----------------------|
| 1955 | 375 | 1968 | 219 |
| 56 | 199 | 69 | 490 |
| 57 | 232 | 70 | 233 |
| 58 | 419 | 71 | 141 |
| 59 | 245 | 72 | 256 |
| 60 | 411 | 73 | 308 |
| 61 | 166 | 74 | 575 |
| 62 | 232 | 75 | 229 |
| 63 | 206 | 76 | 260 |
| 64 | 232 | 77 | 387 |
| 65 | 238 | 78 | 283 |
| 66 | 440 | 79 | 221 |
| 1967 | 180 | 1980 | 250 |

- 8 The maximum annual floods for a river for 60 years were statistically analysed. The sixth largest flood (*i.e.*, No. 6 when arranged in the descending order of flood magnitude) was 480 cumec. Determine:
- the period in which the flood (*i.e.*, 480 cumec) may reoccur;
 - the percentage chance that the flood (*i.e.*, 480 cumec) may occur in any one year.
 - the percentage chance that the flood (*i.e.*, 480 cumec) may not occur in the next 20 years.
 - the probability that the flood (*i.e.*, 480 cumec) may occur in the next 10 years.
- 9 (a) What do you understand by degree of protection in relation to a flood control scheme and what factors govern the degree of protection to be offered ?
- (b) What is the probability that only one flood equal to or exceeding the 50-year flood will occur in a 50-year period? What is the probability that one or more floods equal to or exceeding the '50-year flood' will occur in a 50-year period? (2, 64%)
- 10 (a) Discuss the validity of the probability method of flood estimation. List the demerits, if any.
- (b) Compute the magnitude of the return period of a design flood to provide 60% assurance that failure of a structure would not occur. ($2\frac{1}{2}$ year)
- 11 What return period must a highway engineer assume in his design of a culvert, if he allows a 10% risk that flooding will occur in the next 5 years? (48.1 yr)
- 12 Explain briefly how you would compute the design flood for a spillway in a reservoir. Assume that rainfall-runoff data are available for the basin for about 50 years. You may list out the various methods available and explain any one of them.
- 13 The maximum annual floods for River Tapti for 93 years (1876 to 1968) were statistically analysed, and 17 highest annual floods are given below. Draw the frequency curve and determine:
- the recurrence interval of the highest flood, SPF of 48200 cumec and the design flood of 49500 cumec.
 - the 200-yr, 150-yr, 100-yr and 75-yr flood magnitude.
 - the probability that the flood of 37300 cumec (a) may not occur in the next 10 years (b) may occur in any one year; examine how for case (a) is true.

Maximum annual floods (when water levels at Surat exceeded gauge level 95) of river Tapi during 1876 to 1968

| <i>Year</i> | <i>Month and date</i> | <i>Peak flood (1000 cumec)</i> |
|-------------|------------------------|------------------------------------|
| 1876 | Aug. 29 to Sept. 5 | 21.2 |
| 1882 | Sept. 12 | 21.8 |
| 1883 | July 3 | 30.2 |
| 1884 | Sept. 9 | 24.9 |
| 1894 | July 22 | 23.6 |
| 1914 | Sept. 17 | 21.8 |
| 1930 | Sept. 30 | 22.6 |
| 1933 | Sept. 18 | 25.5 |
| 1937 | Sept. 10 | 20.0 |
| 1942 | Aug. 6 | 22.8 |
| 1944 | Aug. 18 & 24 (2 peaks) | 29.3 |
| 1945 | Sept. 24 | 24.2 |
| 1949 | Sept. 17 | 18.3 |
| 1958 | Sept. 2 | 19.6 |
| 1959 | Sept. 17 | 37.3 |
| 1962 | Sept. 15 | 22.6 |
| 1968 | Aug. 6 | 42.5 |

Hint Since all the 93 annual floods are not given, it is not possible to determine \bar{Q} and σ for Gumbel's method and hence draw the frequency curve of Weibull's.

(94, 180, 210 yr; 49, 46, 43, 40 T cumec; 14.8, 85.2% but has been exceeded in 1968 after 9 years). 'PDS' cannot be applied since there are only 17 events in 93 years.

- 14 (a) Explain the different methods of avoiding damage by floods
 (b) Explain with a neat sketch how flood control is effected by reservoirs with regard to (i) their number, (ii) location, (iii) size, and (iv) operation.
 (c) Is land management effective in flood control?
- 15 (a) Explain the 'tangible and non-tangible' benefits due to flood control.
 (b) Suppose that a flood control project is to be a combined one and involves the construction of a reservoir and levees with channel improvement, explain how would you determine the most economic combination of these procedures.
 (c) Given below is the information regarding flood stage, recurrence interval, total damage and cost of project for giving protection against indicated stage. Work out the benefit-cost ratio and net benefits (*i.e.*, benefits – costs). What is the peak stage against which you would choose to provide protection?

| Peak stage (m) | Total damage below indicated stage (Rs. in millions) | Return period (years) | Annual cost of project (Rs. in millions) |
|----------------|--|-----------------------|--|
| 9 | 0 | 7 | 0.8 |
| 10 | 8 | 10 | 1.2 |
| 11 | 20 | 15 | 1.6 |
| 12 | 40 | 22 | 2.0 |
| 13 | 64 | 30 | 2.6 |
| 14 | 90 | 70 | 3.2 |
| 15 | 120 | 150 | 3.6 |
| 16 | 160 | 300 | 4.0 |

- 16** (a) Explain stage by stage the studies to be made and the field work to be undertaken for preparing an estimate and report for a flood control project.
 (b) Write a note on 'flood forecasting and warning'.
- 17** Write short notes on:
 (a) PMP (b) Flood forecasting and warning
 (c) Rational formula for flood estimation (d) Design flood
 (e) Moisture adjustment (f) Retarding basin
 (g) Fuse plug levee (h) Storm transposition
 (i) Flood embankment
- 18** Statistical analysis of an annual flood series for the period 1876–1968 at a station X on the river Tapti shows that the 100-yr flood has a magnitude of 42800 cumec and a 10-yr flood a magnitude of 22700 cumec. Assuming that the flood peaks are distributed according to the theory of extreme values, determine
 (a) the magnitude of a 20-yr flood.
 (b) the probability of a flood equal to or greater than 35000 cumec occurring
 (i) in the next 10 years,
 (ii) in the next year itself.
 (c) the probability of having at least one 10 year flood in the next 4 years.
 (d) the mean (\bar{Q}) and standard deviation (σ) of the annual floods.
- 19** A cofferdam has to be built in a river to withstand four consecutive flood seasons (*i.e.*, 4 years) and offer protection against a 20-yr flood. The annual flood series for a period of 30 years at the site indicate a maximum flood peak of 8000 cumec and a minimum of 1800 cumec. Assuming that the annual flood peaks plot as a straight line on a semi-log paper (recurrence interval plotted as abscissa to logarithmic scale), estimate the magnitude of the 20-yr flood (without plotting) and determine the probability of its occurrence during the life of the cofferdam.
 (7200 cumec, 18.6%)

- 20 The annual rainfall distribution during a period of 75 years of record at a place is given below.

| <i>Rainfall range</i> | <i>No. of years</i> |
|-----------------------|---------------------|
| <15 cm | 5 |
| 15-24 cm | 12 |
| 25-34 cm | 18 |
| 35-44 cm | 30 |
| ≥45 cm | 10 |

Determine

- (a) the probability of having a rainfall in excess of 45 cm in any one year.
 (b) the probability of the rainfall exceeding 45 cm in three successive years,
 (c) the probability of occurrence of rainfall of less than 20 cm during the next year.
- 21 In a tropical area where there are short storms more or less uniformly distributed throughout the year. there is a 60% chance of rain on any one day. Determine: (i) the probability that there will be no rain on any two successive days, (ii) the probability that it will rain on both days, and (iii) that it will rain on only one of the two days.
- 22 In a certain river, a flood discharge of 2000 cumec was exceeded 48 times during a period of 27 years and a flood of 8000 cumec exceeded twice. Determine their annual probability and average recurrence interval.
 (80%, 0.56-yr, 7%, 14-yr)
- 23 What return period a Municipal Engineer should adopt in the design of a culvert on a drain, if he is willing to accept only a 10% risk of being flooded during the 25 years of the expected life of the culvert?
 [238 yr]
- 24 A 45 min storm produces 30 mm of rain over a catchment of 120 ha. If the time of concentration is 30 min and runoff coefficient is 0.3, estimate the resulting peak flow rate.
 [Hint Use eqs. 8.9 & 8.10.] (Ans. 4.663 cumec)
- 25 The annual floods of a basin were statistically analysed using Gumbel's distribution which yielded $\bar{Q} = 32000$ cumec, and $\sigma = 6000$ cumec. Determine
 (a) the recurrence interval of a flood of magnitude 40000 cumec.
 (b) the probability of the above flood occurring in the next 5 years. (Ans. 33.33 yr, 14.1%)
- 26 The annual floods of River Chambal at Gandhisagar dam were statistically analysed which yielded the 50-yr and 100-yr floods as 40.8 tcm and 46.3 tcm, respectively. Estimate the 500-yr flood magnitude. What is the probability that this flood may occur in the next 100 years.
 (tcm = 1000 cumec) (Ans. 59 tcm)
- 27 The annual floods of a river at a particular site were analysed by Gumbel's method which yielded $\bar{Q} = 1200$ cumec and $\sigma = 650$ cumec. For what discharge you design the structure at this site for 95% assurance that the structure would not fail in the next 50 years. (Ans. 4200 cumec)

Chapter 9

FLOOD ROUTING

9.1 RESERVOIR ROUTING

Flood routing is the process of determining the reservoir stage, storage volume of the outflow hydrograph corresponding to a known hydrograph of inflow into the reservoir; this is called reservoir routing. For this, the capacity curve of the reservoir, *i.e.*, 'storage vs pool elevation', and 'outflow rate vs. pool elevation', curves are required. Storage volumes for different pool elevations are determined by planimetry of the contour map of the reservoir site. For example, the volume of water stored (V) between two successive contours having areas A_1 and A_2 (planimetered) and the contour interval d , is given by

$$\text{Cone formula,} \quad V = \frac{d}{3} (A_1 + A_2 + \sqrt{A_1 A_2}) \quad \dots(9.1)$$

$$\text{Prismoidal formula,} \quad V = \frac{d}{6} (A_1 + A_2 + 4A_m) \quad \dots(9.2)$$

where $A_m = \frac{A_1 + A_2}{2}$, *i.e.*, area midway between the two successive contours. The prismoidal formula is more accurate. The outflow rates are determined by computing the discharge through the sluices and the spillway discharge for different water surface elevations of the reservoir. (*i.e.*, pool elevations):

$$\text{Discharge through sluices,} \quad Q_{sl} = C_d A \sqrt{2gh} \quad \dots(9.3)$$

$$\text{Discharge over spillway crest,} \quad Q_{sp} = CLH^{3/2} \quad \dots(9.4)$$

$$\text{Outflow from the reservoir} \quad O = Q_{sl} + Q_{sp}$$

where h = height of water surface of reservoir above the centre of sluice

H = height of water surface of reservoir above the crest of spillway

C_d = coefficient of discharge for the sluice

C = coefficient of spillway

A = area of sluice opening

L = length of spillway

The problem in flood routing is to determine the relation between the inflow, the outflow and the storage as a function of time. The problem can be solved by applying the hydrologic equation

$$I = O + \Delta S \quad \dots(9.5)$$

where I = inflow rate

O = outflow rate

ΔS = incremental storage, at any instant.

Taking a small interval of time, t (called the routing period and designating the initial and final conditions by subscripts 1 and 2 between the interval, Eq. (9.5) may be written as

$$\left(\frac{I_1 + I_2}{2}\right)t - \left(\frac{O_1 + O_2}{2}\right)t = S_2 - S_1 \quad \dots(9.6)$$

The routing period, t selected should be sufficiently short such that the hydrograph during the interval 1-2 can be assumed as a straight line, *i.e.*, $I_{\text{mean}} = \frac{I_1 + I_2}{2}$.

Eq. (9.6) can be rearranged as

$$\left(\frac{I_1 + I_2}{2}\right)t + S_1 - \frac{O_1 t}{2} = S_2 + \frac{O_2 t}{2} \quad \dots(9.7)$$

After selecting a routing period t , curves of O vs. S , and O vs. $S \pm Ot/2$ on either side of O - S curve are drawn. At the beginning of the routing period all the terms on the left side of Eq. (9.7) are known and the value of the right side terms is found out. Corresponding to this O_2 and $(S - Ot/2)$ are read from the graph, which become the initial values for the next routing period and so on.

This method of flood routing was developed by LG Puls of the US Army Corps of Engineers and is called the ISD (Inflow-storage-discharge) method. Here it is assumed that the outflow (*i.e.*, discharge) from the reservoir is a function of the pool elevation provided that the spillway and the sluices have no gates (*i.e.*, uncontrolled reservoirs) or with constant gate openings, if provided with control gates for which pool elevation vs. discharge curves are drawn.

Eq. (9.6) may be rearranged as

$$(I_1 + I_2) + \left(\frac{2S_1}{t} - O_1\right) = \frac{2S_2}{t} + O_2 \quad \dots(9.8)$$

After selecting a routing period t , a curve of ' $\frac{2S}{t} + O$ ' vs. O' can be drawn since $\left(\frac{2S}{t} + O\right) - 2O = \frac{2S}{t} - O$, a curve of ' $\frac{2S}{t} - O$ ' vs. O' can also be drawn.

At the beginning of the routing period all terms on the left of Eq. (9.8) are known. This method is called modified puls or Storage Indication Method.

Example 9.1 For a reservoir with constant gate openings for the sluices and spillway, pool elevation vs storage and discharge (outflow) curves are shown in Fig. 9.1. The inflow hydrograph into the reservoir is given below:

| | | | | | | | | |
|----------------|-----|-----|-----|-----|-----|-----|-----|-----|
| Time (hr) | 0 | 6 | 12 | 18 | 24 | 30 | 36 | 42 |
| Inflow (cumec) | 50 | 70 | 160 | 300 | 460 | 540 | 510 | 440 |
| Time (hr) | 48 | 54 | 60 | 66 | 72 | 78 | 84 | 90 |
| Inflow (cumec) | 330 | 250 | 190 | 150 | 120 | 90 | 80 | 70 |

Pool elevation at the commencement = 110 m

Discharge at the commencement = 124 cumec

Route the flood through the reservoir by (a) ISD method, and (b) modified Puls method, and compute the outflow hydrograph, the maximum pool elevation reached, the reduction in the flood peak and the reservoir lag.

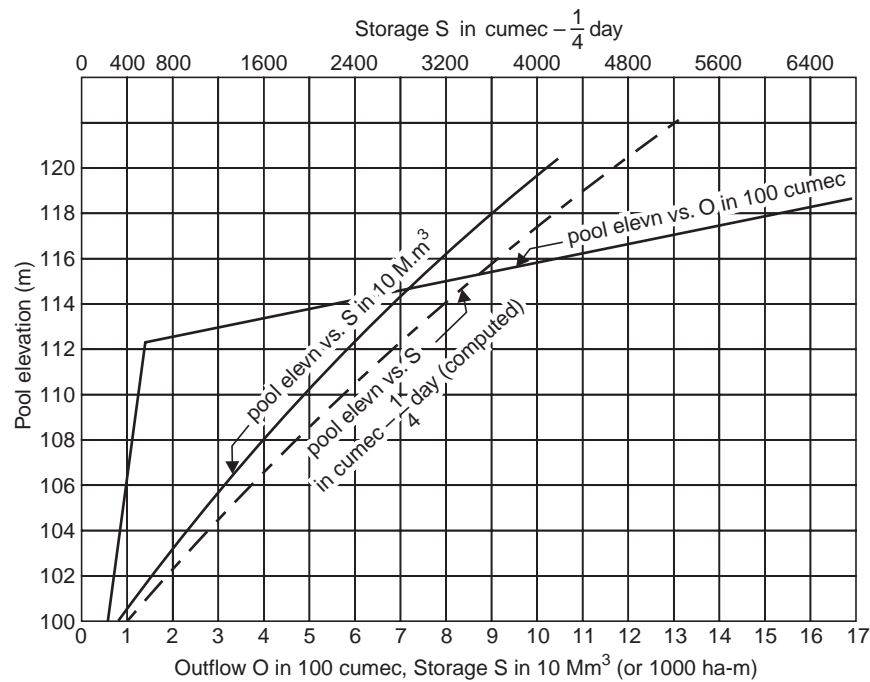

Fig. 9.1 Pool elevation vs. storage and discharge (Example 9.1)

Solution (a) Flood routing by ISD method Take the routing period as 6 hr or $\frac{1}{4}$ day. It is easier to work the flow rates in cumec and the storage volumes in terms of cumec $-\frac{1}{4}$ day. Hence, the storage in Mm^3 is converted to cumec $-\frac{1}{4}$ day by multiplying by 46.3, Table 9.1. Corresponding to an initial pool elevation of 110 m, $O = 124$ cumec, $S = 49.1 Mm^3 = 49.1 \times 46.3 = 2270$ cumec $-\frac{1}{4}$ day, $\frac{Ot}{2} = \frac{O}{2} \times t = \frac{124}{2} \text{ cumec} \times \frac{1}{4} \text{ day} = 62 \text{ cumec} - \frac{1}{4} \text{ day}$, $S + \frac{Ot}{2} = 2270 + 62 = 2332$ cumec $-\frac{1}{4}$ day, and $S - \frac{Ot}{2} = 2270 - 62 = 2208$ cumec $-\frac{1}{4}$ day. First 'O vs. S' curve is drawn. For a particular O on the S curve, $\frac{O}{2}$ abscissa units may be set off on either side of the S curve and this is repeated for other values of O. The points obtained on either side of S curve plot $S + \frac{Ot}{2}$ and $S - \frac{Ot}{2}$ curves as shown in Fig. 9.2.

Table 9.1 Tabulation for drawing (i) $S \pm \frac{Ot}{2}$ and (ii) $\frac{2S}{t} \pm 0$ curves for routing the flood through the reservoir (Example 9.1)

| Pool elevation | Outflow O | Storage S | Computation for I.S.D. method ($t = 6hr = \frac{1}{4}$ day) | | | Computation for modified Puls method | | | |
|----------------|-------------|-------------|---|---------------------------------------|---|---|---|---|---|
| | | | (Mm^3) | $(cumec - \frac{1}{4} \text{ day}^*)$ | $\frac{Ot}{2}$ ($\frac{cumec}{\frac{1}{4} \text{ day}}$) | $S + \frac{Ot}{t}$ ($\frac{cumec}{\frac{1}{4} \text{ day}}$) | $S - \frac{Ot}{2}$ ($\frac{cumec}{\frac{1}{4} \text{ day}}$) | $\frac{2S}{t}$ ($\frac{cumec}{\frac{1}{4} \text{ day}}$) | $\frac{2S}{t} + O$ ($\frac{cumec}{\frac{1}{4} \text{ day}}$) |
| 100 | 60 | 8.7 | 400 | 30 | 430 | 370 | 800 | 860 | 740 |
| 102 | 70 | 15.1 | 700 | 35 | 735 | 665 | 1400 | 1470 | 1330 |
| 104 | 86 | 23.4 | 1480 | 43 | 1123 | 1037 | 2160 | 2246 | 2074 |
| 106 | 100 | 32.0 | 1480 | 50 | 1530 | 1430 | 2960 | 3060 | 2860 |
| 108 | 110 | 40.0 | 1850 | 55 | 1905 | 1795 | 3700 | 3810 | 3590 |
| 110 | 124 | 49.1 | 2270 | 62 | 2332 | 2208 | 4540 | 4664 | 4416 |
| 112 | 138 | 58.3 | 2700 | 69 | 2769 | 2631 | 5400 | 5538 | 5262 |
| 113 | 310 | 63.0 | 2920 | 155 | 3075 | 2765 | 5840 | 6150 | 5530 |
| 114 | 550 | 68.3 | 3160 | 275 | 3435 | 2885 | 6320 | 6870 | 5770 |
| 115 | 800 | 73.5 | 3400 | 400 | 3800 | 3000 | 6800 | 7600 | 6000 |
| 116 | 1030 | 78.8 | 3650 | 515 | 4165 | 3135 | 7300 | 8330 | 6270 |
| 117 | 1280 | 83.8 | 3880 | 640 | 4520 | 3240 | 7760 | 9040 | 6480 |
| 118 | 1520 | 90.0 | 4160 | 760 | 4920 | 3400 | 8320 | 9840 | 6800 |
| 120 | — | 101.0 | 4680 | — | — | — | — | — | — |

*1 cumec - $\frac{1}{4}$ day = $1 \times 6 \times 60 = 21600 \text{ m}^3$. 1 million m^3 (Mm^3) = $10^6/21600 = 46.3$ cumec - $\frac{1}{4}$ day.

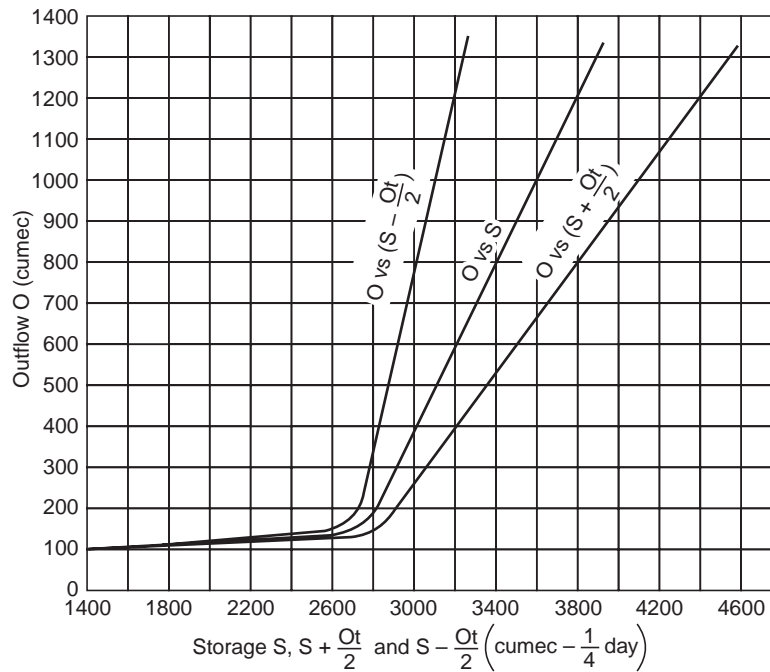

Fig. 9.2 Reservoir routing by ISD method (Example 9.1)

For routing the flood by the I.S.D. method, Table 9.2, for the known outflow at the commencement of 124 cumec, $S - \frac{Ot}{2}$ is read from the curve as 2208 cumec - $\frac{1}{4}$ day and to this

$$\frac{I_1 + I_2}{2} t = \frac{50 + 70}{2} \text{ cumec} \times \frac{1}{4} \text{ day} = 60 \text{ cumec} - \frac{1}{4} \text{ day}$$

is added to get the right hand side of Eq. (9.7); i.e., $S + \frac{Ot}{2} = 2268$ and corresponding to this $O = 120$ cumec is read from the graph which

is the outflow at the beginning of the next routing period. Corresponding to this $O = 120$ cumec, the pool elevation of 109.2 m is read from the 'pool elevations vs. O ' curve. Corresponding to this $O = 120$ cumec, $S - \frac{Ot}{2} = 2040$ is read from the graph and $\frac{I_1 + I_2}{2} t = \frac{70 + 160}{2} t$

$$= 115 \text{ cumec} - \frac{1}{4} \text{ day}$$

is added to get $S + \frac{Ot}{2} = 2155$ for which O is read as 116 cumec and pool elevation as 108.4 m. Thus the process is repeated till the flood is completely routed through the reservoir and the outflow hydrograph is obtained as shown in Fig. 9.3.

(b) Flood routing by modified Puls method: Corresponding to the initial pool elevation of 110 m, $O = 124$ cumec, $S = 2270$ cumec - $\frac{1}{4}$ day, $\frac{2S}{t} = \frac{2 \times 2270 \text{ cumec} - \frac{1}{4} \text{ day}}{\frac{1}{4} \text{ day}} = 4540$ cumec,

$$\frac{2S}{t} + O = 4540 + 124 = 4664 \text{ cumec}$$

and $\frac{2S}{t} - O = 4540 - 124 = 4416$ cumec. Thus, for other

values of O , values of $\frac{2S}{t} + O$ and $\frac{2S}{t} - O$ are computed and ‘ O vs. $\frac{2S}{t} + O$ and $\frac{2S}{t} - O$ ’ curves are drawn as shown in Fig. 9.4.

Table 9.2 Reservoir routing—ISD method [Eq. 9.7] (Example 9.1)

| <i>Time</i> (hr) | <i>Inflow</i> <i>I</i> (cumec) | $\frac{I_1 + I_2}{2} t$ (cumec- $\frac{1}{4}$ day) | <i>Outflow O</i> (cumec) | $S - \frac{Ot}{2}$ (cumec- $\frac{1}{4}$ day) | $S + \frac{Ot}{2}$ (cumec- $\frac{1}{4}$ day) | <i>Pool</i> elevation (m) |
|---------------------|--------------------------------------|--|-----------------------------|---|---|---------------------------------|
| 0 | 50 | | 124 | | | 110.0 |
| | | 60 | + 120 | 2208 | 2268 | |
| 6 | 70 | | 120 | | | 109.2 |
| | | 115 | + 116 | 2040 | 2155 | |
| 12 | 160 | | 116 | | | 108.4 |
| | | 230 | + 119 | 1960 | 2190 | |
| 18 | 300 | | 119 | | | 109.1 |
| | | 380 | | 2020 | 2400 | |
| 24 | 460 | | 122 | | | 109.6 |
| | | 500 | | 2080 | 2580 | |
| 30 | 540 | | 130 | | | 110.8 |
| | | 525 | | 2380 | 2905 | |
| 36 | 510 | | 195 | | | 112.5 |
| | | 475 | | 2730 | 3205 | |
| 42 | 440 | | 395 | | | 113.4 |
| | | 385 | | 2820 | 3205 | |
| 48 | 330 | | 395 | | | 113.4 |
| | | 290 | | 2920 | 3110 | |
| 54 | 250 | | 335 | | | 113.1 |
| | | 220 | | 2790 | 3010 | |
| 60 | 190 | | 265 | | | 112.8 |
| | | 170 | | 2760 | 2930 | |
| 66 | 150 | | 210 | | | 112.6 |
| | | 135 | | 2740 | 2875 | |
| 72 | 120 | | 170 | | | 112.4 |
| | | 105 | | 2720 | 2825 | |
| 78 | 90 | | 145 | | | 112.3 |
| | | 85 | | 2700 | 2785 | |
| 84 | 80 | | 132 | | | 111.2 |
| | | 75 | | 2650 | 2725 | |
| 90 | 70 | | 130 | | | 110.8 |

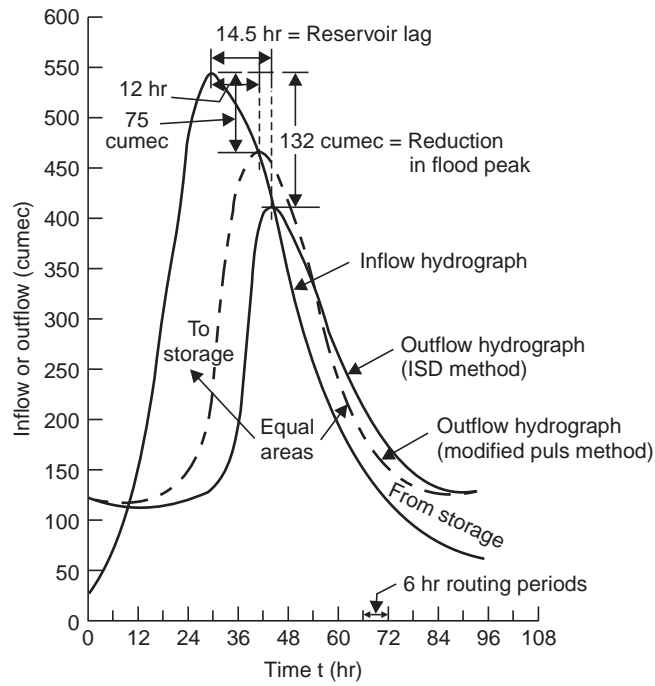

Fig. 9.3 Reservoir routing (Example 9.1)

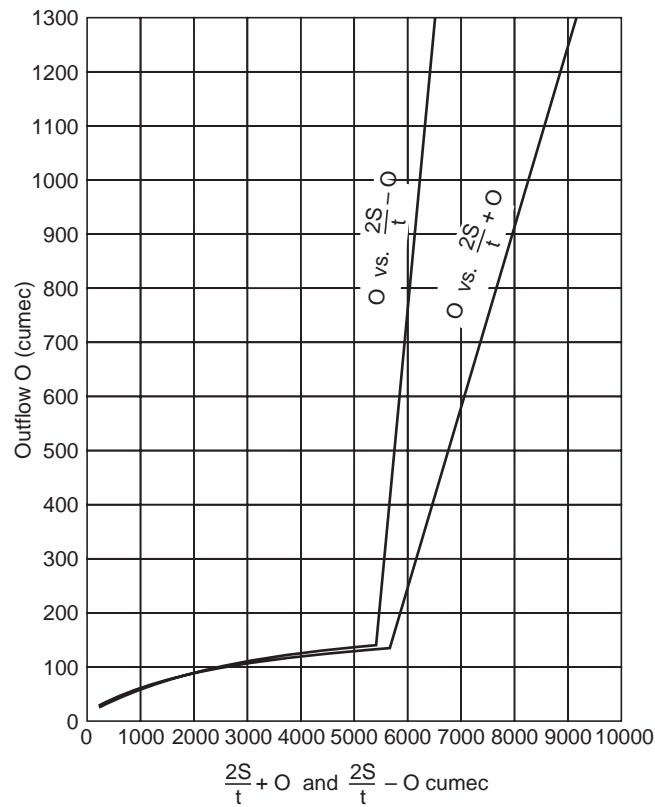

Fig. 9.4 Reservoir routing by modified Puls method (Example 9.1)

For routing the flood by the modified Puls method, Table 9.3, corresponding to the initial pool elevation of 110 m, $O = 124$ cumec, $\frac{2S}{t} + O = 4664$ cumec and $\frac{2S}{t} - O = 4416$ cumec are read off. For this $\frac{2S}{t} - O = 4416$ cumec, $I_1 + I_2 = 50 + 70 = 120$ cumec is added to get the right hand side of Eq. (9.8), i.e., $\frac{2S}{t} + O = 4416 + 120 = 4536$ cumec. For this value of $\frac{2S}{t} + O, O = 123$ cumec, and $\frac{2S}{t} - O = 4290$ cumec are read off from the curves. For $O = 123$ cumec, the pool elevation of 109.8 m is read off from the 'O vs pool elevation curve'. These values become the initial values for the next routing period. Again, for $\frac{2S}{t} - O = 4290$ cumec, $I_1 + I_2 = 70 + 160 = 230$ cumec is added to get the right hand side of Eq. (9.8), i.e., $\frac{2S}{t} + O = 4290 + 230 = 4520$ cumec for which O and $\frac{2S}{t} - O$ values are read off and pool elevation obtained, which become the initial values for the next routing period. Thus the process is repeated till the flood is completely routed through the reservoir and the outflow hydrograph is obtained as shown in Fig. 9.3 by dashed line.

Table 9.3 Reservoir routing–modified Puls method [Eq. 9.8]. (Example 9.1)

| Time (hr) | Inflow O (cumec) | $\frac{2S}{t} - O^*$ (cumec) | $\frac{2S}{t} + O$ (cumec) | Outflow O (cumec) | Pool elevation (m) |
|-----------|-----------------------|---------------------------------|-------------------------------|------------------------|-----------------------|
| 0 | 50 | 4416 | 4464 | 124 | 110.0 |
| 6 | 70 | 4290 | 4536 | 123 | 109.8 |
| 12 | 160 | 4276 | 4520 | 122 | 109.6 |
| 18 | 300 | 4482 | 4736 | 126 | 111.8 |
| 24 | 460 | 4986 | 5248 | 131 | 111.0 |
| 30 | 540 | 5506 | 5986 | 240 | 112.7 |
| 36 | 510 | 5696 | 6556 | 430 | 113.5 |
| 42 | 440 | 5716 | 6646 | 465 | 113.6 |
| 48 | 330 | 5666 | 6486 | 410 | 113.4 |
| 54 | 250 | 5586 | 6246 | 330 | 113.0 |
| 60 | 190 | 5526 | 6026 | 250 | 112.7 |
| 66 | 150 | 5466 | 5866 | 200 | 112.5 |
| 72 | 120 | 5436 | 5736 | 150 | 112.3 |
| 78 | 90 | 5476 | 5646 | 135 | 111.6 |
| 84 | 80 | 5278 | 5546 | 134 | 111.4 |
| 90 | 70 | | 5428 | 130 | 110.8 |

$$* \frac{2S}{t} - O = \left(\frac{2S}{t} + O \right) - 2O$$

Results.

| | <i>ISD method</i> | <i>Modified Puls method</i> |
|---------------------------------|-----------------------------|-----------------------------|
| (i) Maximum pool elevn. reached | $\approx 113.5 \text{ m}^*$ | 113.6 m |
| (ii) Reduction in flood peak | 132 cumec | 75 cumec |
| (iii) Reservoir lag | $14\frac{1}{2} \text{ hr}$ | 12 hr |

*To pass the crest of the outflow hydrograph.

9.2 STREAM FLOW ROUTING

In a stream channel (river) a flood wave may be reduced in magnitude and lengthened in travel time *i.e.*, attenuated, by storage in the reach between two sections. The storage in the reach may be divided into two parts—prism storage and wedge storage, Fig. 9.5, since the water surface is not uniform during the floods. The volume that would be stored in the reach if the flow were uniform throughout, *i.e.*, below a line parallel to the stream bed, is called ‘prism storage’ and the volume stored between this line and the actual water surface profile due to outflow being different from inflow into the reach is called ‘wedge storage’. During rising stages the wedge storage volume is considerable before the outflow actually increases, while during falling stages inflow drops more rapidly than outflow, the wedge storage becoming negative.

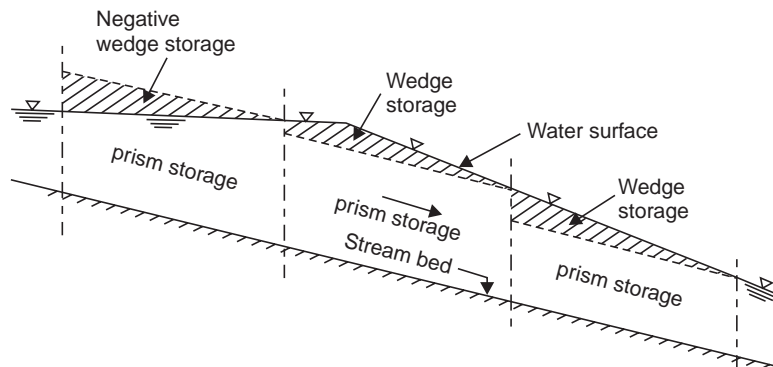

Fig. 9.5 Storage in a stream channel during a flood wave

In the case of stream-flow routing, the solution of the storage equation is more complicated, than in the case of reservoir routing, since the wedge storage is involved. While the storage in a reach depends on both the inflow and outflow, prism storage depends on the outflow alone and the wedge storage depends on the difference ($I - O$). A common method of stream flow routing is the Muskingum method (McCarthy, 1938) where the storage is expressed as a function of both inflow and outflow in the reach as

$$S = K [xI + (1 - x) O] \quad \dots(9.9)$$

where K and x are called the Muskingum coefficients (since the Eq. (9.9) was first developed by the U.S. Army Corps of Engineers in connection with the flood control schemes in the Muskingum River Basin, Ohio), K is a storage constant having the dimension of time and x is

a dimensionless constant for the reach of the river. In natural riverchannels x ranges from 0.1 to 0.3. The Eq. (9.9) in most flood flows approaches a straight line. Trial values of x are assumed and plots of 'S vs. $[xI + (1 - x) O]$ ' are in the form of storage loops; for a particular value of x , the plot is a straight line and the slope of the line gives K . If S is in cumec-day and I, O are in cumec, K is in day.

After determining the values of K and x , the outflow O from the reach may be obtained by combining and simplifying the two equations.

$$\left(\frac{I_1 + I_2}{2}\right) t - \left(\frac{O_1 + O_2}{2}\right) t = S_2 - S_1 \tag{9.10}$$

same as (9.6)

and
$$S_2 - S_1 = K [x (I_2 - I_1) + (1 - x) (O_2 - O_1)] \tag{9.11}$$

(Eq. 9.11 is the same as Eq. (9.9)); for a discrete time interval the following equation may be obtained

$$O_2 = C_0 I_2 + C_1 I_1 + C_2 O_1 \tag{9.12}$$

where

$$C_0 = -\frac{Kx - 0.5t}{K - Kx + 0.5t} \tag{9.12 a}$$

$$C_1 = \frac{Kx + 0.5t}{K - Kx + 0.5t} \tag{9.12 b}$$

$$C_2 = \frac{K - Kx - 0.5t}{K - Kx + 0.5t} \tag{9.12 c}$$

Combining Eq. (9.12 a, b, c) gives

$$C_0 + C_1 + C_2 = 1 \tag{9.12 d}$$

where t is the routing period. The routing period should be less than the time of travel for the flood wave through the reach, otherwise it is possible that the wave crest may pass completely through the reach during the routing period. Usually the routing period is taken as about 1/3 to 1/4 of the flood wave travel time through the reach (obtained from the inflow-hydrograph).

If there is a local inflow due to a tributary entering the mainstream, it should be added to I or O accordingly as it enters the reach at the upstream or downstream end, or the local inflow may be divided, a portion added to I and another portion added to O .

A number of methods have been developed for flood routing. The numerical method of solution of the routing equations is tedious but has the advantage of easy checking and filling. The Sorensen's graphical method of reservoir routing has the advantage that variable time periods can be used. Cheng's graphical method is used for stream flow routing. Quite a number of mechanical instruments, flood routing slide rules and electronic computers, etc. have been used to facilitate computations.

Example 9.2 *The inflow and outflow hydrographs for a reach of a river are given below. Determine the value of the Muskingum coefficients K and x for the reach.*

| | | | | | | | | | | |
|-----------------|----|-----|-----|-----|-----|-----|-----|-----|-----|-----|
| Time (hr) | 0 | 24 | 48 | 72 | 96 | 120 | 144 | 168 | 192 | 216 |
| Inflow (cumec) | 35 | 125 | 575 | 740 | 456 | 245 | 144 | 95 | 67 | 50 |
| Outflow (cumec) | 39 | 52 | 287 | 624 | 638 | 394 | 235 | 142 | 93 | 60 |

Solution From the daily readings of the inflow and outflow hydrographs, a routing period $t = 24 \text{ hr} = 1 \text{ day}$ is taken. The mean storage is determined from Eq. (9.10) and then the cumulative storage S is tabulated. For trial values of $x = 0.2, 0.25$ and 0.3 , the values of $[xI + (1 - x)O]$ are computed in Table 9.4. Storage loops for the reach, *i.e.*, curves of S vs. $[xI + (1 - x)O]$ for each trial value of x are plotted as shown in Fig. 9.6. By inspection, the middle value of $x = 0.25$ approximates a straight line and hence this value of x is chosen. K is determined by measuring the slope of the median straight line which is found to be 0.7 day. Hence, for the given reach of the river, the values of the Muskingum coefficients are

$$x = 0.25, K = 0.7 \text{ day}$$

Example 9.3 The inflow hydrograph readings for a stream reach are given below for which the Muskingum coefficients of $K = 36 \text{ hr}$ and $x = 0.15$ apply. Route the flood through the reach and determine the reduction in peak and the time of peak of outflow.

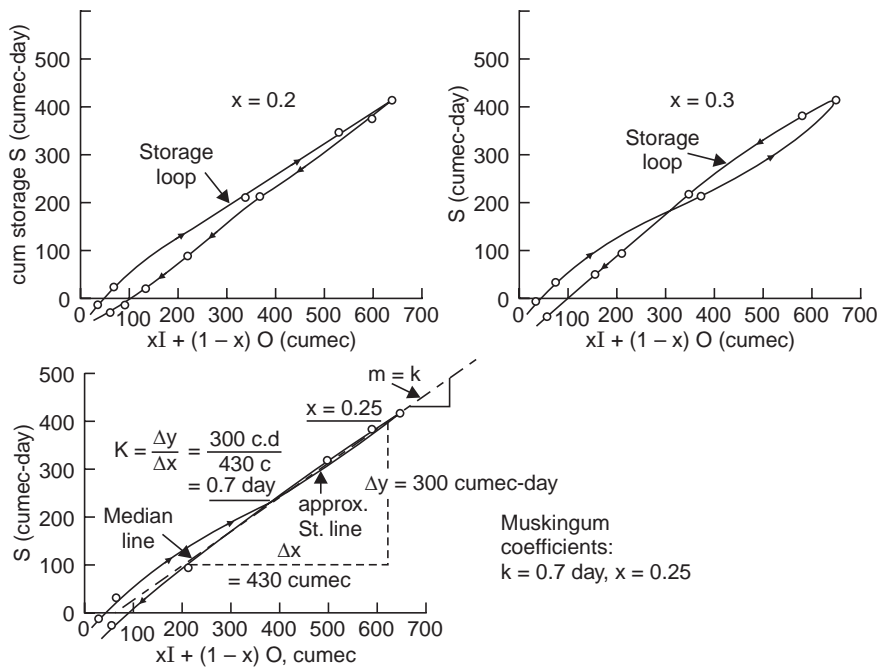

Fig. 9.6 Storage loops for the reach of the river (Example 9.2)

Outflow at the beginning of the flood may be taken as the same as inflow.

| | | | | | | | | | | | |
|-----------------|-----|-----|-----|-----|-----|-----|-----|-----|-----|-----|-----|
| Time (hr) | 0 | 12 | 24 | 36 | 48 | 60 | 72 | 84 | 96 | 108 | 120 |
| Inflow (cumecc) | 42 | 45 | 88 | 272 | 342 | 288 | 240 | 198 | 162 | 133 | 110 |
| Time (hr) | 132 | 144 | 156 | 168 | 180 | 192 | 204 | 216 | 228 | 240 | |
| Inflow (cumecc) | 90 | 79 | 68 | 61 | 56 | 54 | 51 | 48 | 45 | 42 | |

Solution Eq. 9.12: $O_2 = C_0 I_2 + C_1 I_1 + C_2 O_1$

$x = 0.15, K = 36 \text{ hr} = 1.5 \text{ day}$; take the routing period (from the inflow hydrograph readings) as $12 \text{ hr} = \frac{1}{2} \text{ day}$. Compute C_0, C_1 and C_2 as follows:

Table 9.4 Determination of the Muskingum coefficients K and x for a reach of the river. (Example 9.2)

| Time (hr) | Inflow I (cumec) | Outflow O (cumec) | I-O (cumec) | Mean storage (cumec- day) | cumulative storage (cumec- day) | x = 0.2 | | X = 0.25 | | X = 0.3 | | |
|--------------|------------------------|-------------------------|----------------|------------------------------------|--|---------|---------------------------|----------|----------------------------|---------|---------------------------|-------|
| | | | | | | 0.2 I | 0.8 O Total (cumec) | 0.25 I | 0.75 O Total (cumec) | 0.3 I | 0.7 O Total (cumec) | |
| 0 | 35 | 39 | -4 | -2 | -2 | 7 | 31.2 | 8.75 | 29.25 | 10.5 | 27.3 | 37.8 |
| 24 | 125 | 52 | 73 | 34 | 32 | 25 | 41.6 | 31.25 | 39.0 | 37.4 | 36.4 | 73.9 |
| 48 | 575 | 287 | 288 | 180 | 212 | 115 | 229.6 | 143.75 | 215 | 172.5 | 200.9 | 373.4 |
| 72 | 740 | 624 | 116 | 202 | 414 | 148 | 499.2 | 185.0 | 468 | 222.0 | 436.8 | 658.8 |
| 96 | 456 | 638 | -182 | -33 | 381 | 91.2 | 510.4 | 114.0 | 478 | 136.8 | 446.6 | 583.4 |
| 120 | 245 | 394 | -149 | -165 | 216 | 49 | 315.2 | 61.25 | 295.5 | 73.5 | 275.8 | 349.3 |
| 144 | 144 | 235 | -91 | -120 | 96 | 28.8 | 188.0 | 36.0 | 176.3 | 43.2 | 164.5 | 207.7 |
| 168 | 95 | 142 | -47 | -69 | 27 | 19.0 | 113.6 | 23.75 | 101.64 | 28.5 | 99.4 | 127.9 |
| 192 | 67 | 93 | -26 | -37 | -10 | 13.4 | 74.4 | 16.75 | 69.7 | 20.1 | 65.1 | 85.2 |
| 216 | 50 | 60 | -10 | -18 | -28 | 10 | 48.0 | 12.5 | 45.0 | 15.0 | 42.0 | 57.0 |

$$C_0 = -\frac{Kx - 0.5t}{K - Kx + 0.5t} = -\frac{15 \times 0.15 - 0.5 \times \frac{1}{2}}{1.5 - 1.5 \times 0.15 + 0.5 \times \frac{1}{2}} = -\frac{-0.025}{1.525} = 0.02$$

$$C_1 = \frac{Kx + 0.5t}{K - Kx + 0.5t} = \frac{15 \times 0.15 + 0.5 \times \frac{1}{2}}{1.525} = 0.31$$

$$C_2 = \frac{K - Kx - 0.5t}{K - Kx + 0.5t} = \frac{1.5 - 1.5 \times 0.15 - 0.5 \times \frac{1}{2}}{1.525} = 0.67$$

Check: $C_0 + C_1 + C_2 = 0.02 + 0.31 + 0.67 = 1$

$\therefore O_2 = 0.02 I_2 + 0.31 I_1 + 0.67 O_1$

In Table 9.5, I_1, I_2 are known from the inflow hydrograph, and O_1 is taken as I_1 at the beginning of the flood since the flow is almost steady.

Table 9.5 Stream flow routing—Muskingum method
[Eq. 9.12]. (Example 9.3)

| Time (hr) | Inflow I (cumec) | 0.02 I_2 (cumec) | 0.31 I_1 (cumec) | 0.67 O_1 (cumec) | Outflow O (cumec) |
|--------------|--------------------------|-----------------------|-----------------------|-----------------------|---------------------------|
| 0 | 42 | — | — | — | 42* |
| 12 | 45 | 0.90 | 13.0 | 28.2 | 42.1 |
| 24 | 88 | 1.76 | 14.0 | 28.3 | 44.0 |
| 36 | 272 | 5.44 | 27.3 | 29.5 | 62.2 |
| 48 | 342 | 6.84 | 84.3 | 41.7 | 132.8 |
| 60 | 288 | 5.76 | 106.0 | 89.0 | 200.7 |
| 72 | 240 | 4.80 | 89.2 | 139.0 | 233.0 |
| 84 | 198 | 3.96 | 74.4 | 156.0 | 234.0 |
| 96 | 162 | 3.24 | 61.4 | 157.0 | 221.6 |
| 108 | 133 | 2.66 | 50.2 | 148.2 | 201.0 |
| 120 | 110 | 2.20 | 41.2 | 134.5 | 178.9 |
| 132 | 90 | 1.80 | 34.1 | 119.8 | 155.7 |
| 144 | 79 | 1.58 | 27.9 | 104.0 | 133.5 |
| 156 | 68 | 1.36 | 24.4 | 89.5 | 115.3 |
| 163 | 61 | 1.22 | 21.1 | 77.4 | 99.7 |
| 180 | 56 | 1.12 | 18.9 | 66.8 | 86.8 |
| 192 | 54 | 1.08 | 17.4 | 58.2 | 76.7 |
| 204 | 51 | 1.02 | 16.7 | 51.4 | 69.1 |
| 216 | 48 | 1.00 | 15.8 | 46.3 | 63.1 |
| 228 | 45 | 0.90 | 14.8 | 42.3 | 58.0 |
| 240 | 42 | 0.84 | 13.9 | 38.9 | 53.6 |

* O_1 is assumed equal to $I_1 = 42$ cumec

$$\therefore O_2 = 0.02 \times 45 + 0.31 \times 42 + 0.67 \times 42 = 42.06 \text{ cumec}$$

This value of O_2 becomes O_1 for the next routing period and the process is repeated till the flood is completely routed through the reach. The resulting outflow hydrograph is plotted as shown in Fig. 9.7. The reduction in peak is 108 cumec and the lag time is 36 hr, *i.e.*, the peak outflow is after 84 hr ($= 3\frac{1}{2}$ days) after the commencement of the flood through the reach.

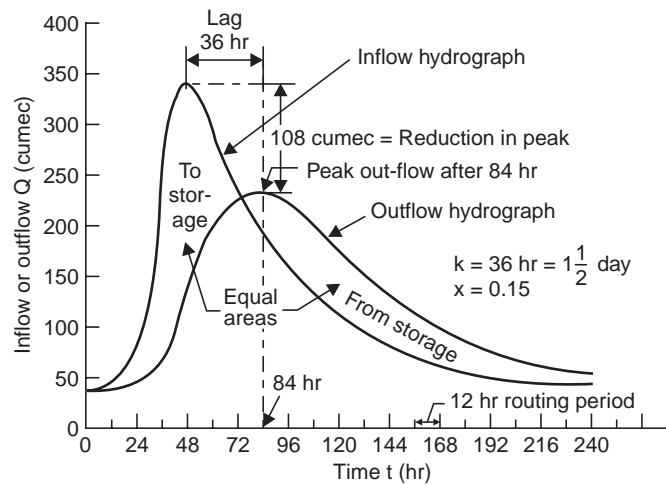

Fig. 9.7 Streamflow routing by Muskingum method (Example 9.3)

QUIZ IX

I Match the items in 'A' with the items in 'B'

A

- (i) Flood routing
- (ii) ISD method
- (iii) Modified Puls method
- (iv) Stream-flow routing
- (v) Wedge storage
- (vi) Prism storage
- (vii) Reservoir routing
- (viii) Streamflow routing

B

- (a) Muskingum method
- (b) $f(I - 0)$
- (c) $f(0)$
- (d) Sorensen's graphical method
- (e) Cheng's graphical method
- (f) $\frac{2S}{t} \pm 0$ curves
- (g) $S \pm \frac{Ot}{2}$ curves
- (h) Outflow hydrograph

II Say 'true' or 'false', if false, give the correct statement:

- (i) In flood routing through reservoir

Given are:

- (a) Pool elevation vs. storage
- (b) Pool elevation vs. outflow (discharge)
- (c) Flood hydrograph of inflow

Required to find at any time after the commencement of flood

- (a) Reservoir stage (pool elevation) (b) Storage volume
 (c) Outflow (d) Reduction in flood peak
 (e) Maximum pool elevation reached (f) Reservoir lag
- (ii) The outflow consists of discharge over the spillway only
 (iii) The routing period should be greater than the time of travel of the flood wave through the reach.
 (iv) The routing period should be sufficiently short such that the hydrograph during this interval can be assumed as a straight line.
 (v) Reservoir routing by modified Puls method is simpler than I.S.D. method.
 (vi) Stream flow routing is more complicated than reservoir routing since the prism storage is involved.
 (vii) While storage is simply a function of discharge in reservoir routing, it (storage) is a function of both inflow and outflow in streamflow routing since wedge storage is involved.
 (viii) Inflow is a parameter in the storage equation of streamflow routing to adequately represent the prism storage.
 (ix) The storage in a reach consists of prism storage and wedge storage, the former is due to the nonuniformity of water surface while the latter is beneath a line parallel to the stream bed.
 (x) The wedge storage volume becomes negative during rising stages.
 (xi) The wedge storage depends on the outflow alone while the prism storage depends on the difference of inflow and outflow.
 (xii) The routing period is taken as about 1/3 to 1/4 of the flood wave travel time through the reach and is obtained from the flood hydrograph of inflow.
 (xiii) Variable time periods can be used in the Sorensen's graphical method of reservoir routing.
 (xiv) Cheng's graphical method is used for reservoir routing.
 (xv) Local inflow due to a tributary poses a problem in streamflow routing.
 (xvi) Though mechanical and electronic devices have been developed for flood routing computations, the numerical methods have the advantage of easy checking and filling.

(false: ii, iii, vi, viii, ix, x, xi, xiv)

III Choose the correct statement/s in the following:

1 Given a hydrograph of inflow into the reservoir, flood routing is the process of determining.

- (i) reservoir pool elevation (ii) reservoir storage
 (iii) hydrograph of outflow from the reservoir
 (iv) discharge over the spillway and through sluice ways
 (v) exclusion of silt-charge from the reservoir
 (vi) head available for the power plant (vii) all the above items

2 Wedge storage in a channel reach is a function of

- (i) inflow into the reach (ii) outflow from the reach
 (iii) difference between the inflow and outflow
 (iv) the routing period (v) prism storage
 (vi) local inflow (from a tributary joining at mid-reach)

(vii) all the above factors

(1 - i, ii, iii; 2 - iii, vi)

QUESTIONS

- 1 (a) Define 'flood routing'. What are the usual assumptions made in routing a flood in a reservoir?
 (b) Explain clearly the I.S.D. curves method of reservoir flood routing. What are the factors to be considered in choosing the routing period?
- 2 (a) Take any two flood routing methods you know of and show that they are only solutions of the continuity equation $I - O = \frac{dS}{dt}$.

- (b) A retarding basin has storage and discharge characteristics as given below. The dam has an ungated sluice 1.5 m dia with its centre at elevation 157.5 m and a spillway at crest elevation 226.5 m. Discharge given below for pool elevations above 226.5 m include both sluice and spillway discharge. The inflow hydrograph is also given below.

Route the flood through the reservoir

(i) by ISD method

(ii) by the modified Puls method

Determine the maximum pool elevation reached, the reduction in flood peak and the reservoir lag. Pool elevation at commencement = 157.8 m (for which the discharge = 5.95 cumec).

(i) 'Pool Elevation vs. Storage' and Discharge data:

| Pool Elvn. (m) | Storage (ham) (= $10^4 m^3$) | Discharge (cumec) |
|-------------------|----------------------------------|----------------------|
| 157.5 | 0.085 | 3.9 |
| 159 | 0.368 | 17.3 |
| 162 | 1.33 | 29.8 |
| 168 | 7.6 | 45.5 |
| 174 | 21.2 | 57.0 |
| 180 | 43.8 | 66.7 |
| 186 | 80.4 | 75.0 |
| 192 | 136.0 | 82.8 |
| 198 | 208 | 89.5 |
| 204 | 297 | 96 |
| 210 | 400 | 102 |
| 216 | 520 | 108 |
| 222 | 655 | 114 |
| 225 | 728 | 116 |
| 226.5 | 764 | 117 |
| 227.4 | 787 | 119 |
| 228.0 | 805 | 289 |

(ii) Inflow hydrograph data

| Time (hr) | Inflow (cumec) | Time (hr) | Inflow (cumec) |
|--------------|-------------------|--------------|-------------------|
| 0 | 15 | 36 | 141 |
| 6 | 57 | 42 | 93 |
| 12 | 159 | 48 | 60 |
| 18 | 258 | 54 | 33 |
| 24 | 246 | 60 | 18 |
| 30 | 198 | | |

(Hint Take routing period $t = 6 \text{ hr} = 1/4 \text{ day}$)

Draw the curves:

- (i) Pool elevation vs. discharge (outflow)
- (ii) Discharge (outflow) in cumec vs. $S \pm \frac{Ot}{2}$ in cumec $- \frac{1}{4}$ day, for ISD method of routing.
- (iii) Discharge (outflow) in cumec vs. $\frac{2S}{t} \pm O$ in cumec, for modified Puls method of routing.

- 3 (a) How does 'stream flow routing' differ from reservoir flood routing?
- (b) The inflow hydrograph readings for a stream reach are given below for which the Muskingum coefficients of $K = 30 \text{ hr}$ and $x = 0.2$ apply. Route the flood through the reach and determine the reduction in peak and the time of peak of outflow. Outflow at the beginning of the flood may be taken as the same as inflow.

| Time (hr) | Inflow (cumec) | Time (hr) | Inflow (cumec) |
|--------------|-------------------|--------------|-------------------|
| 0 | 15 | 132 | 32 |
| 12 | 16 | 144 | 28 |
| 24 | 31 | 156 | 24 |
| 36 | 96 | 168 | 22 |
| 48 | 121 | 180 | 20 |
| 60 | 102 | 192 | 19 |
| 72 | 85 | 204 | 18 |
| 84 | 70 | 216 | 17 |
| 96 | 57 | 228 | 16 |
| 108 | 47 | 240 | 15 |
| 120 | 39 | | |

- 4 (a) Show that storage in a stream reach can be expressed in terms of inflow and outflow in the form:

$$S = K [xI + (1 - x) O]$$

- (b) The inflow and outflow hydrographs for a reach of a river are given below. Determine the best values of the Muskingum coefficients K and x for the reach.

| <i>Time</i> (hr) | <i>Inflow</i> (cumec) | <i>Outflow</i> (cumec) |
|---------------------|--------------------------|---------------------------|
| 0 | 20 | 20 |
| 12 | 191 | 30 |
| 24 | 249 | 120 |
| 36 | 164 | 176 |
| 48 | 110 | 164 |
| 60 | 82 | 135 |
| 72 | 62 | 116 |
| 84 | 48 | 90 |
| 96 | 32 | 68 |
| 108 | 28 | 52 |

Chapter 10

STORAGE, PONDAGE AND FLOW DURATION CURVES

10.1 RESERVOIR MASS CURVE AND STORAGE

During high flows, water flowing in a river has to be stored so that a uniform supply of water can be assured, for water resources utilisation like irrigation, water supply, power generation, etc. during periods of low flows of the river.

A mass diagram is a graphical representation of cumulative inflow into the reservoir versus time which may be monthly or yearly. A mass curve is shown in Fig. 10.1 for a 2-year period. The slope of the mass curve at any point is a measure of the inflow rate at that time. Required rates of draw off from the reservoir are marked by drawing tangents, having slopes equal to the demand rates, at the highest points of the mass curve. The maximum departure between the demand line and the mass curve represents the storage capacity of the reservoir required to meet the demand. A demand line must intersect the mass curve when extended forward, otherwise the reservoir is not going to refill. The vertical distance between the successive tangents represent the water wasted over the spillway. The salient features in the mass curve of flow in Fig. 10.1 are:

- a-b*: inflow rate exceeds the demand rate of x cumec and reservoir is overflowing
- b*: inflow rate equals demand rate and the reservoir is just full
- b-c*: inflow rate is less than the demand rate and the water is drawn from storage
- c*: inflow rate equals demand rate and S_1 is the draw off from the reservoir (Mm^3)
- c-d*: inflow rate exceeds demand rate and the reservoir is filling
- d*: reservoir is full again
- d-e*: same as *a-b*
- e*: similar to *b*
- e-f*: similar to *b-c*
- f*: inflow rate equals demand rate and S_2 is the draw off from the reservoir
- f-g*: similar to *c-d*

To meet the demand rate of x cumec the departure $S_2 > S_1$; hence, the storage capacity of the reservoir is $S_2 \text{ Mm}^3$. If the storage capacity of the reservoir, from economic considerations, is kept as $S_1 \text{ Mm}^3$, the demand rate of x cumec can not be maintained during the time *e-f* and it can be at a lesser rate of y cumec ($y < x$).

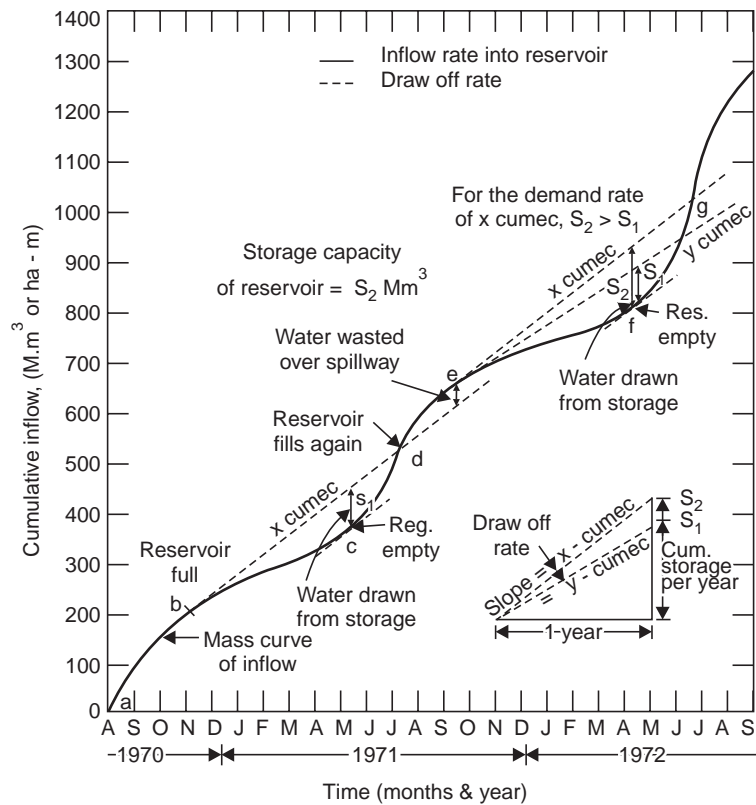

Fig. 10.1 Storage capacity of reservoir from mass curve

The use of mass curve is to determine:

- (i) the storage capacity of the reservoir required to meet a particular withdrawal rate.
- (ii) the possible rate of withdrawal from a reservoir of specified storage capacity.

The observed inflow rates have to be adjusted for the monthly evaporation from the reservoir surface, precipitation, seepage through the dam, inflow from adjacent basins, required releases for downstream users, sediment inflow, etc. while calculating the storage capacity of the reservoir.

The average flow figures for the site of a proposed dam are collected for about 10 years. From this record the flow figures for the driest year are used for drawing the mass flow curve. Graphical analysis is enough for preliminary studies. Final studies are made by tabular computation. If tangents are drawn to the crest and trough of the mass curve such that the departure of the lines represents the specified reservoir capacity, the slope of the tangent at the crest gives the continuous flow that can be maintained with the available storage capacity. From this the greatest continuous power output for the available fall at the site for a given plant efficiency and load factor can be determined.

From the daily flow data a hydrograph or a bar graph is drawn for the maximum flood during the period of 10 years and the spillway capacity to pass this flood with the available storage capacity is determined. Thus, the power and the flood control potentialities of the site are investigated. Also see Appendix-C.

The mass curve of water utilisation need not be a straight line. The dashed curve in Fig. 10.2 shows the cumulative requirements of water use in different months as compared with monthly cumulatively inflow. The maximum draft in the reservoir (*i.e.*, maximum departure of the water use and inflow curves) occurs by the end of April. The reservoir again becomes full by the end of September when the two curves intersect.

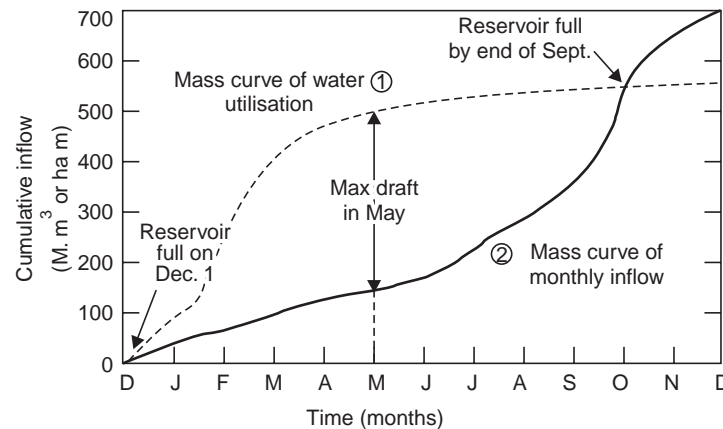

Fig. 10.2 Mass curves of water utilisation and monthly inflow

Example 10.1 The following is a record of the mean monthly discharges of a river in a dry year. The available fall is 80 m. Determine

(i) the minimum capacity of a reservoir if the entire annual inflow is to be drawn off at a uniform rate (with no flow going into waste over the spillway).

(ii) the amount of water which must be initially stored to maintain the uniform draw off.

(iii) the uniform power output assuming a plant efficiency of 70%.

(iv) If the amount of water initially stored is 125 Mm^3 , the maximum possible draw off rate and the amount of water wasted over the spillway (assuming the same reservoir capacity determined in (i) above).

(v) if the largest reservoir that can be economically constructed is of capacity 125 Mm^3 , the maximum possible output and the amount of water wasted over the spillway.

(vi) the capacity of the reservoir to produce 22.5 megawatts continuously throughout the year.

| Month | Mean flow (cumec) | Month | Mean flow (cumec) |
|-------|----------------------|-------|----------------------|
| Jan. | 29.7 | July | 68.0 |
| Feb. | 75.3 | Aug. | 50.2 |
| March | 66.8 | Sept. | 74.5 |
| April | 57.2 | Oct. | 66.8 |
| May | 23.2 | Nov. | 40.5 |
| June | 26.3 | Dec. | 26.3 |

Solution Take each month as 30 days for convenience; 1 month = 30 days \times 86400 sec = 2.592 \times 10⁶ sec. Inflow volume in each month = monthly discharge \times 2.592 Mm³; and monthly inflow and cumulative inflow are tabulated in Table 10.1.

Table 10.1 Cumulative inflow into reservoir

| Month | Mean flow (cumec) | Inflow volume (Mm ³) | cumulative inflow (Mm ³) | Month | Mean flow (cumec) | Inflow volume (Mm ³) | cumulative inflow (Mm ³) |
|-------|----------------------|--|--|-------|----------------------|--|--|
| Jan. | 29.7 | 77 | 77 | July | 68.0 | 176 | 897 |
| Feb. | 75.3 | 195 | 272 | Aug. | 50.2 | 130 | 1027 |
| Mar. | 66.8 | 173 | 445 | Sept. | 74.5 | 193 | 1220 |
| April | 57.2 | 148 | 593 | Oct. | 66.8 | 173 | 1393 |
| May | 23.2 | 60 | 653 | Nov. | 40.5 | 105 | 1498 |
| June | 26.3 | 68 | 721 | Dec. | 26.3 | 68 | 1566 |

Plot the mass curve of flow as cumulative inflow vs month as shown in Fig. 10.3.

(i) Join OA by a straight line; the slope of OA , *i.e.*, 1566 Mm³/yr or (1566 \times 10⁶)m³/(365 \times 86400) sec = 49.7 cumec is the uniform draw off throughout the year with no spill over the spillway. Draw $BC \parallel OA$, $GH \parallel OA$, B , G being the crests of the mass curve; $EH = FG$

Minimum capacity of reservoir = $DE + EH = 150 + 20 = 170 \text{ Mm}^3$

Note If the capacity is less than this, some water will be wasted and if it is more than this, the reservoir will never get filled up.

(ii) Amount of water to be initially stored for the uniform draw off of 49.7 cumec = $DE = 150 \text{ Mm}^3$

(iii) Continuous uniform power output in kW, $P = \frac{\rho_w g QH}{1000} \times \eta_0$

where ρ_w = mass density of water, 1000 kg/m³

Q = discharge into turbines

H = head on turbines (\approx available fall)

η_0 = overall or plant efficiency

$$\begin{aligned} \therefore P &= \frac{1000 \times 9.81 \times 49.7 \times 80}{1000} \times 0.70 \\ &= 27400 \text{ kW} \end{aligned}$$

or

$$= 27.4 \text{ MW}$$

(iv) If the amount of water initially stored is only 125 M.m³, measure $DI = 125 \text{ M.m}^3$, join BI and produce to J . The slope of the line BJ is the maximum possible draw off rate. Let the line BJ intersect the ordinate through O (*i.e.*, the cumulative inflow axis) at K . The vertical intercept $KJ' = 1430 \text{ Mm}^3$ and the slope of this line = 1430 Mm³/yr = 45.4 cumec which is the maximum possible draw off rate.

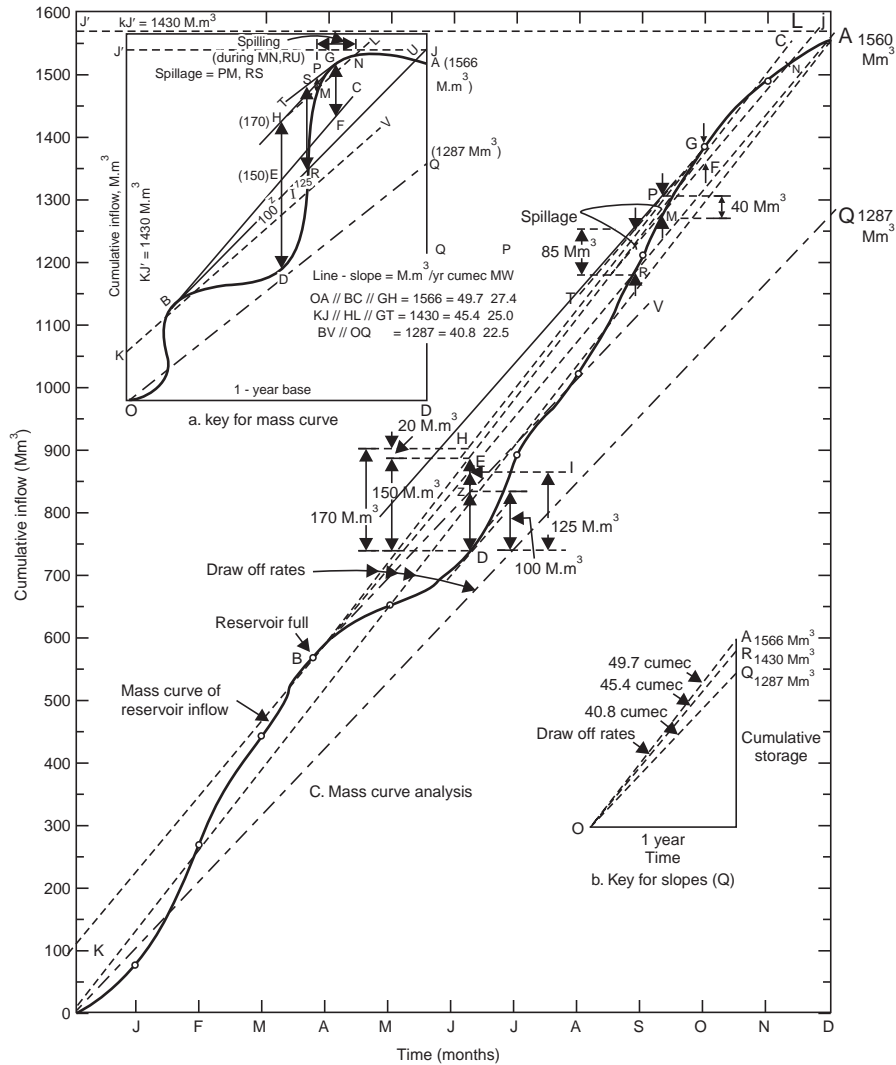

Fig. 10.3 Mass curve studies in reservoir design (Example 10.1)

To maintain the same reservoir capacity of 170 M.m^3 , draw the straight line $HL \parallel KJ$ intersecting the mass curve of flow at M and N . Draw the straight line $GT \parallel HL$. The vertical intercept PM gives the amount of water wasted over the spillway (during the time period MN) which is 40 M.m^3 .

(v) If the reservoir capacity is limited to 125 M.m^3 from economic considerations, the line KJ intersects the mass curve of flow at R . Let the vertical at R meet the line GT ($GT \parallel KJ$) at S . In this case the amount of water wasted over the spillway = $RS = 85 \text{ M.m}^3$. The maximum possible output in this case for a uniform draw off rate of 45.4 cumec is

$$P' = 27.4 \times \frac{45.4}{49.7} = 25 \text{ MW}$$

(vi) For a continuous power output of 22.5 MW the uniform draw off rate can be determined from the equation

$$22500 \text{ kW} = \frac{1000 \times 9.81 \times Q \times 80}{1000} \times 0.70$$

$$Q = 40.8 \text{ cumec}$$

which can also be calculated as $49.7 \times \frac{22.5}{27.4} = 40.8 \text{ cumec} = 40.8 (365 \times 86400 \text{ sec}) = 1287 \text{ Mm}^3/\text{yr}$.

On the 1-year base, draw the ordinate at the end of December = 1287 M.m³ and join the line *OQ* (dashed line). The slope of this line gives the required draw off rate (40.8 cumec) to produce a uniform power output of 22.5 mW. Through *B* and *D*, *i.e.*, the crest and the trough draw tangents parallel to the dashed line *OQ* (*BV* ∥ *OQ*). The vertical intercept between the two tangents *DZ* gives the required capacity of the reservoir as 100 Mm³.

10.2 FLOW DURATION CURVES

Flow duration curves show the percentage of time that certain values of discharge weekly, monthly or yearly were equalled or exceeded in the available number of years of record. The selection of the time interval depends on the purpose of the study. As the time interval increases the range of the curve decreases, Fig. 10.4. While daily flow rates of small storms are useful for the pondage studies in a runoff river power development plant, monthly flow rates for a number of years are useful in power development plants from a large storage reservoir. The flow duration curve is actually a river discharge frequency curve and longer the period of record, more accurate is the indication of the long term yield of a stream. A flat curve indicates a river with a few floods with large ground water contribution, while a steep curve indicates frequent floods and dry periods with little ground water contribution. Since the area under the curve represents the volume of flow, the storage will affect the flow duration curve as shown by the dashed line in Fig. 10.5; *i.e.*, reducing the extreme flows and increasing the very low flows.

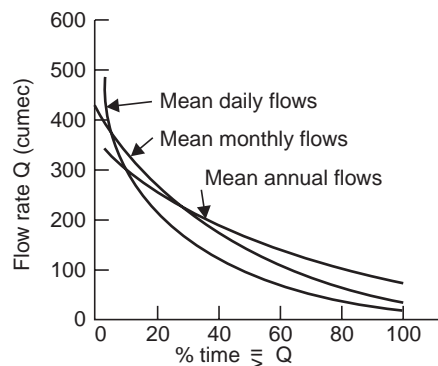

Fig. 10.4 Flow duration curves—effect of observation period

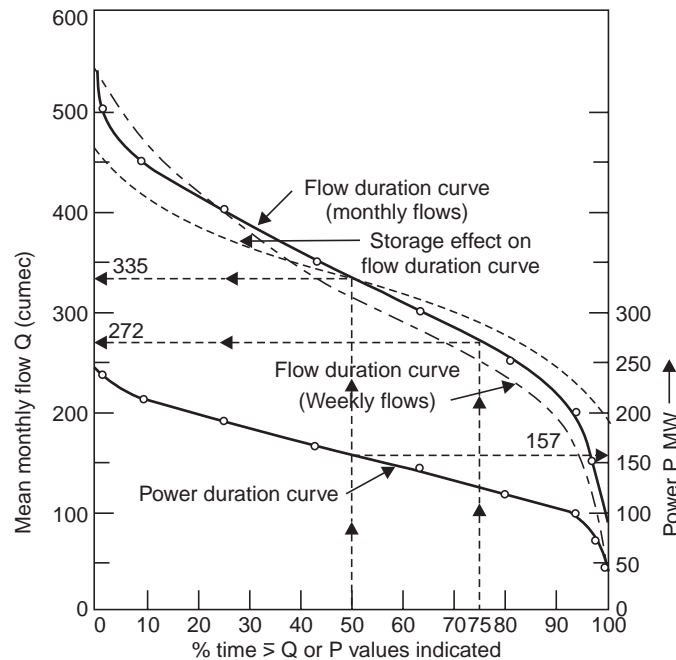

Fig. 10.5 Flow duration and power duration curves (Example 10.2)

Since drought is often defined in terms of a fixed period of time with less than some minimum amount of rainfall, the flow duration curves are useful for determining the duration of floods or droughts, the latter being of prime importance in the semi-arid regions. Duration curves for long periods of runoff are also useful for deciding the flow rates to be used for particular purposes, say, for power development.

The usual procedure is to arrange the flow values (or range of flow values weekly, monthly or yearly) in the available period of record (usually a minimum of 10 years) in the ascending order of magnitude and the number of occurrences of each flow value (or range of flow values). From this the number of times and the percent of time each flow value (or range of flow values) has been equalled or exceeded in the period of record may be obtained. The duration curve is constructed by plotting each flow value (or lower value of the class interval) against the percent of time it has been equalled or exceeded. The power duration curve is the same as the flow duration curve, the discharge scale being converted to power units corresponding to the available head (assuming the head constant) since

$$\text{Power in kW,} \quad P = \frac{\rho_w g QH}{1000} \times \eta_0$$

$$\text{or,} \quad P = a \text{ constant} \times Q$$

where Q is the flow value being equalled or exceeded during a certain percent of time.

Flow duration curves are useful in the studies relating to navigation problems, water power, water supply, irrigation and sanitation.

Example 10.2 The following data are obtained from the records of the mean monthly flows of a river for 10 years. The head available at the site of the power plant is 60 m and the plant efficiency is 80%.

| Mean monthly flow range (cumec) | No. of occurrences (in 10-yr period) |
|------------------------------------|---|
| 100-149 | 3 |
| 150-199 | 4 |
| 200-249 | 16 |
| 250-299 | 21 |
| 300-349 | 24 |
| 350-399 | 21 |
| 400-499 | 20 |
| 450-499 | 9 |
| 500-549 | 2 |

(a) Plot

(i) The flow duration curve (ii) The power duration curve

(b) Determine the mean monthly flow that can be expected and the average power that can be developed.

(c) Indicate the effect of storage on the flow duration curve obtained.

(d) What would be the trend of the curve if the mean weekly flow data are used instead of monthly flows.

Solution (a) The mean monthly flow ranges are arranged in the ascending order as shown in Table 10.2. The number of times that each mean monthly flow range (class interval, C.I.) has been equalled or exceeded (m) is worked out as cumulative number of occurrences starting from the bottom of the column of number of occurrences, since the C.I. of the monthly flows, are arranged in the ascending order of magnitude. It should be noted that the flow values are arranged in the ascending order of magnitude in the flow duration analysis, since the minimum

Table 10.2 Flow duration analysis of mean monthly flow data of a river in a 10 yr period (Example 10.2)

| Mean monthly flow class interval C.I. (cumec) | No. of occurrences (in 10-yr period) | No. of time equalled or exceeded (m) | Percent of time lower value of CI equalled or exceeded $= \frac{m}{n} \times 100\%$ | Monthly power $P = 0.472 Q$ (MW) $Q =$ lower value of C.I. |
|--|---|---|---|--|
| 100-149 | 3 | 120 | 100 | 47.2 |
| 150-199 | 4 | 117 | 97.5 | 70.8 |
| 200-249 | 16 | 113 | 94.2 | 94.4 |
| 250-299 | 21 | 97 | 80.8 | 118 |
| 300-349 | 24 | 76 | 63.3 | 142 |
| 350-399 | 21 | 52 | 43.3 | 165 |
| 400-499 | 20 | 31 | 25.8 | 189 |
| 450-499 | 9 | 11 | 9.2 | 212 |
| 500-549 | 2 | 2 | 1.7 | 236 |
| Total $n = 120$ | | | | |

Note: For drought-duration studies, $m =$ No. of times equal to or less than the flow value and has to be worked from the top; percent of time \leq the flow value is $\frac{m}{n} \times 100$. In this example, $m = 3, 7, 23, 44, \dots$ and % of time $\leq Q$ are 2.5, 5.83, 19.2, 36.7., respectively (from top).

continuous flow that can be expected almost throughout the year (*i.e.*, for a major percent of time) is required particularly in drought duration and power duration studies, while in flood flow analysis the CI may be arranged in the descending order of magnitude and m is worked out from the top as cumulative number of occurrences since the high flows are of interest. The percent of time that each CI is equalled or exceeded is worked out as the percent of the total number of occurrences (m) of the particular CI out of the 120 (= 10 yr \times 12 = n) mean monthly

flow values, *i.e.*, = $\frac{m}{n} \times 100$. The monthly power developed in megawatts,

$$P = \frac{gQH}{1000} \times \eta_0 = \left(\frac{9.81 \times 60}{1000} \times 0.80 \right) Q$$

$$P = 0.472 Q$$

where Q is the lower value of the CI. Thus, for each value of Q , P can be calculated.

(i) The flow duration curve is obtained by plotting Q vs. percent of time, Fig. 10.5, (Q = lower value of the CI).

(ii) The power duration curve is obtained by plotting P vs. percent of time, Fig. 10.5.

(b) The mean monthly flow that can be expected is the flow that is available for 50% of the time *i.e.*, 357.5 cumec from the flow duration curve drawn. The average power that can be developed *i.e.*, from the flow available for 50% of the time, is 167 MW, from the power duration curve drawn.

(c) The effect of storage is to raise the flow duration curve on the dry weather portion and lower it on the high flow portion and thus tends to equalise the flow at different times of the year, as indicated in Fig. 10.5.

(d) If the mean weekly flow data are used instead of the monthly flow data, the flow duration curve lies below the curve obtained from monthly flows for about 75% of the time towards the drier part of the year and above it for the rest of the year as indicated in Fig. 10.5.

In fact the flow duration curve obtained from daily flow data gives the details more accurately (particularly near the ends) than the curves obtained from weekly or monthly flow data but the latter provide smooth curves because of their averaged out values. What duration is to be used depends upon the purpose for which the flow duration curve is intended.

10.3 PONDAGE

While storage refers to large reservoirs to take care of monthly or seasonal fluctuations in the river flow, pondage usually refers to the small storage at the back of a weir, in run-of-river plants, for temporarily storing water during non-working hours, idle days and low load periods for use during hours of peak load demand. Run-of-river plants are feasible for streams which have a minimum dry weather flow or receive flow as regulated by any storage reservoir upstream.

Pondage factor is the ratio of the total inflow hours in a week to the total number of hours of working of the power plant in that week. For example, assuming constant stream flow, if a power plant operates for 6 days in a week at 8 hours per day, then the pondage factor would be $\frac{7 \times 24}{6 \times 8} = 3.5$, and if the plant works only for 5 days in a week, the pondage factor

would be $\frac{7 \times 24}{5 \times 8} = 4.2$ and the pondage required in the latter case would be $\frac{48 + 16}{24} \times$ daily flow volume = $\frac{8}{3}$ of daily flow-volume. Thus the pondage factor serves as a rough guide of the amount of pondage required when the stream flow is constant and the plant works only for a part of the period. Pondage is needed to cover the following four aspects:

- (i) To store the idle day flow.
- (ii) For use during hours of peak load.
- (iii) To balance the fluctuations in the stream flow.
- (iv) To compensate for wastage (due to leakage) and spillage.

Example 10.3 *The available flow for 97% of the time (i.e., in a year) in a river is 30 cumec. A run-of-river plant is proposed on this river to operate for 6 days in a week round the clock. The plant supplies power to a variable load whose variation is given below:*

| Period (hr) | 0–6 | 6–12 | 12–18 | 18–24 |
|---|-----|------|-------|-------|
| $\frac{\text{Load during period}}{\text{24-hr average load}}$ ratio | 0.6 | 1.4 | 1.5 | 0.5 |

The other relevant data are given below:

| | |
|---|-----------------------------|
| Head at full pond level | = 16 m |
| Maximum allowable fluctuation of pond level | = 1 m |
| Plant efficiency | = 80% |
| Pondage to cover inflow fluctuations | = 20% of average daily flow |
| Pondage to cover wastage and spillage | = 10% |

Determine:

- (i) the average load that can be developed
- (ii) daily load factor
- (iii) plant capacity
- (iv) weekly energy output
- (v) pondage required and the surface area of the pond for satisfactory operation

Solution (i) 7 days flow has to be used in 6 days

\therefore Average flow available for power development

$$Q = 30 \times \frac{7}{6} = 35 \text{ cumec}$$

Since maximum allowable fluctuation of pond level is 1 m, average head

$$H = \frac{16 + 15}{2} = 15.5 \text{ m}$$

The average load that can be developed

$$\begin{aligned} P &= \frac{gQH}{1000} \times \eta_0 \\ &= \frac{9.81 \times 35 \times 15.5}{1000} \times 0.8 = 4.27 \text{ MW} \end{aligned}$$

$$(ii) \text{ Daily load factor} = \frac{\text{average load}}{\text{peak load}} = \frac{1}{1.5} = \mathbf{0.67}$$

$$(iii) \text{ Plant capacity} = 4.27 \times 1.5 = \mathbf{6.4 \text{ MW}}$$

$$(iv) \text{ Weekly energy output} = \text{Average load in kW} \times \text{No. of working hours} \\ = (4.27 \times 1000)(6 \times 24) = \mathbf{6.15 \times 10^5 \text{ kWh}}$$

It should be noted that the installed capacity has to be equal to the peak load and the number of units (kWh) generated will be governed by the average load.

(v) Pondage required

$$(a) \text{ to store the idle day's flow} = 30 \times 86400 = 2.592 \times 10^6 \text{ m}^3, \text{ or } 2.592 \text{ Mm}^3$$

(b) to store the excess flow during low loads to meet the peak load demand. Since power developed is proportional to discharge (assuming constant average head of 15.5 m), flow required during peak load periods of 6.00 to 12.00 hr is (1.4 – 1) 35 cumec and from 12.00 to 18.00 hr is (1.5 – 1) 35 cumec.

$$\therefore \text{ pondage to meet peak load demand} \\ = (0.4 + 0.5) 35 \text{ cumec for 6 hr} \\ = (0.9 \times 35)(6 \times 60 \times 60) \\ = 6.81 \times 10^5 \text{ m}^3, \text{ or } 0.681 \text{ Mm}^3$$

$$(c) \text{ pondage to cover inflow fluctuations} \\ = (0.20 \times 30) 86400 \\ = 5.18 \times 10^5 \text{ m}^3, \text{ or } 0.518 \text{ Mm}^3$$

$$\text{Total of (a), (b) and (c)} = 3.791 \text{ Mm}^3$$

$$\text{Add 10\% for wastage and spillage} = \mathbf{0.379 \text{ Mm}^3}$$

$$\text{Total pondage required} = 4.170 \text{ Mm}^3$$

Since the maximum fluctuation of pond level is 1 m

$$\text{the surface area of pond} = 4.170 \times 10^6 \text{ m}^2$$

$$\text{or } 4.17 \text{ km}^2, \text{ or } \mathbf{417 \text{ ha}}$$

Example 10.4 A run-of-river hydroelectric plant with an effective head of 22 m and plant efficiency of 80% supplies power to a variable load as given below:

| | Time (hr) | Load (1000 kW) | | Time (hr) | Load (1000 kW) |
|----|-----------|----------------|--|-----------|----------------|
| MN | 0-2 | 11.4 | | 12-14 | 44.2 |
| | 2-4 | 5.6 | | 14-16 | 44.4 |
| | 4-6 | 25.6 | | 16-18 | 74.2 |
| | 6-8 | 53.2 | | 18-20 | 37.8 |
| | 8-10 | 44.8 | | 20-22 | 30.0 |
| N | 10-12 | 39.4 | | 22-24 | 18.0 |

Draw the load curve and determine:

- (i) the minimum average daily flow to supply the indicated load.
- (ii) pondage required to produce the necessary power at the peak.
- (iii) the plant load factor.

Solution (i) The load curve is shown in Fig. 10.6.

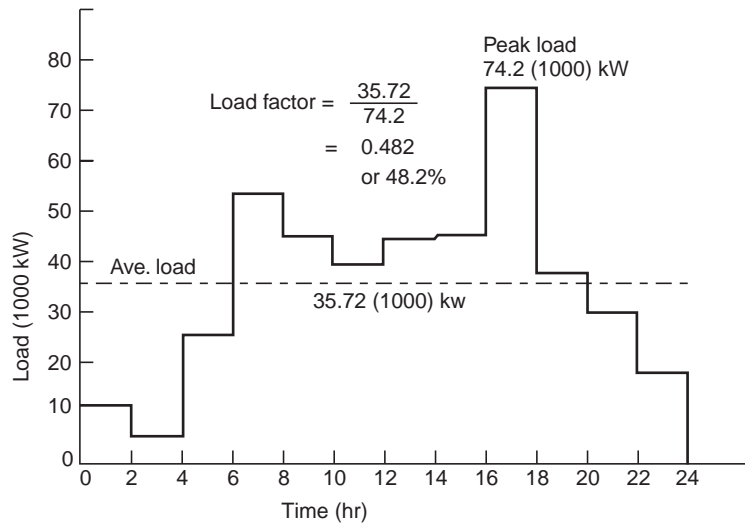

Fig. 10.6 Daily load curve (Example 10.4)

Total of loads at 2 hr intervals = 428.6 kW

$$\text{Average load} = \frac{428.6 \times 1000 \text{ kW} \times 2\text{hr}}{24 \text{ hr}} = 35.72 \times 1000 \text{ kW}$$

Flow (Q) required to develop the average load

$$\frac{1000 \times 9.81 \times Q \times 22}{1000} \times 0.8 = 35.72 \times 1000$$

$$\therefore Q = 207 \text{ cumec}$$

(ii) Flow required to produce the required load demand

$$Q = \frac{207}{35.72} \times \text{Load in 1000 kW}$$

$$\therefore Q = 5.8 \times \text{Load in 1000 kW}$$

To determine the pondage capacity the following table is prepared:

| | Time (hr) | Load (1000 kW) P | Required flow (cumec) $5.8 P$ | Deviation from the average flow of 207 cumec | |
|-----|--------------|--------------------------|--|---|-------------------|
| | | | | Deficiency (cumec) | Excess (cumec) |
| MN: | 0-2 | 11.4 | 66.10 | | 140.90 |
| | 2-4 | 5.6 | 32.46 | | 174.54 |
| | 4-6 | 25.6 | 148.40 | | 58.60 |
| | 6-8 | 53.2 | 308.20 | 101.20 | |
| N: | 8-10 | 44.8 | 260.00 | 53.00 | |
| | 10-12 | 39.4 | 228.50 | 21.50 | |
| | 12-14 | 44.2 | 256.00 | 49.00 | |
| | 14-16 | 44.4 | 257.40 | 50.40 | |

(Contd.)...page 292

| | | | | |
|--------|--------------|--------|---------------|---------------|
| 16-18 | 74.2 | 430.00 | 223.00 | |
| 18-20 | 37.8 | 219.40 | 12.40 | |
| 20-22 | 30.0 | 174.00 | | 33.00 |
| 22-24 | 18.0 | 104.30 | | 102.70 |
| Total: | <u>428.6</u> | | <u>510.50</u> | <u>509.74</u> |

From the above table

Total deficiency = total excess = 510 cumec

$$\therefore \text{Pondage capacity required} = 510 \text{ cumec for 2 hr} \\ = 510 (2 \times 60 \times 60) = \mathbf{3.67 \text{ Mm}^3}$$

$$(iii) \text{ Plant Load factor} = \frac{\text{average load}}{\text{peak load}}$$

$$\text{L.F.} = \frac{35.72}{74.20} = 0.482 \text{ or } \mathbf{48.2\%}$$

QUIZ X

I Choose the correct statement/s in the following:

- 1 From a reservoir mass curve the following information may be obtained:
 - (i) the storage capacity required for a uniform discharge and power output.
 - (ii) the maximum discharge possible and power output for a specified storage capacity.
 - (iii) the month when the reservoir is empty or just full.
 - (iv) the months during which water is overflowing over the spillway.
 - (v) the reservoir pool elevation at any time.
 - (vi) all the above.
- 2 A flow duration curve indicates
 - (i) the stream flow available for different percent of time
 - (ii) the firm power
 - (iii) the duration of floods or droughts
 - (iv) the effect of storage
 - (v) the power available for different percent of time
 - (vi) all the above times.
- 3 Pondage is required across a river
 - (i) which becomes dry in summer
 - (ii) which gets occasional releases from an upstream reservoir
 - (iii) which has a sustained dry weather flow
 - (iv) to take care of seasonal fluctuations of streamflow
 - (v) to store water during off-hours, idle day and low load periods, for use during hours of peak load
 - (vi) to compensate for the losses due to evaporation, leakage and spillage
 - (vii) for all the above cases.

(1. vi; 2. vi; 3. iii, iv, v, vi)

II Match the items in 'A' with items in 'B'

A

- (i) Storage
- (ii) Pondage
- (iii) Minimum hydrorate
- (iv) Drought-duration

B

- (a) 97% of time on power-duration curve
- (b) Arid region
- (c) Run-of-river plant
- (d) Reservoir mass curve

III Say 'true' or 'false'; if false, give the correct statement:

- (i) A mass curve is a graphical representation of cumulative inflow into the reservoir versus time.
- (ii) The vertical distance between the successive tangents to the mass curve peaks (the slopes of the tangents = demand rates) represents the storage capacity of the reservoir.
- (iii) The slope of the mass curve at any point gives the inflow rate at that time into the reservoir.
- (iv) The draw-off rates are marked by drawing tangents at the peaks, having slopes equal to the demand rates.
- (v) The maximum departure between the demand line and the mass curve gives the water wasted over the spillway.
- (vi) A demand line must intersect the mass curve when extended forward, otherwise the reservoir is not going to refill.
- (vii) The maximum departure of the mass curve of water use and mass curve of inflow indicates the month of maximum draft in the reservoir.
- (viii) The weekly flow duration curve lies above that of the monthly flow for about 75% of the time (towards the drier part of the year) and below it for the rest of the year.
- (ix) Though the daily flow duration curve gives the details more accurately (particularly near the ends), the weekly or monthly flow duration curves plot smooth curves (because of their averaged out values).
- (x) Larger the period of record, more accurate and flatter is the flow duration curve.
- (xi) The effect of storage is to lower the flow duration curve on the dry weather portion and raise it on the high flow portion, thus depicting marked variation in the flow at different times of the year.
- (xii) The pondage factor for a constant river discharge into a pond with 8-hour plant operation per day for 6 days in a week is 3.5, neglecting Sunday (idle-day) and the pondage required is $\frac{5}{3}$ of the daily-flow volume.
- (xiii) Run-of-river plants are feasible for streams, which do not have a sustained dry weather flow or receive flow releases occasionally as regulated by an upstream reservoir.
- (xiv) The flow-duration curves are useful for drought-duration studies particularly in semi-arid regions. (false: *ii, v, vii, x, xi, xii*)

QUESTIONS

- 1 (a) Sketch a mass curve of run-off and explain how it is helpful in determining:
- (a) the storage required to satisfy a given constant demand.
 - (b) the safe yield available from a given storage.
- (b) The estimated monthly flow in a river is as follows:

| <i>Month</i> | <i>Flow (Mm³)</i> | <i>Month</i> | <i>Flow (Mm³)</i> |
|--------------|----------------------------------|--------------|----------------------------------|
| Jan. | 7.6 | July | 10.7 |
| Feb. | 19.5 | Aug. | 13.0 |
| March | 17.3 | Sept. | 19.2 |
| April | 10.5 | Oct. | 17.2 |
| May | 5.9 | Nov. | 10.5 |
| June | 6.8 | Dec. | 6.8 |

The available fall is 42 m. What size of reservoir will be necessary to give the greatest continuous uniform output and what will be this power if the plant efficiency is 70%. If the largest reservoir, which can be economically constructed has a capacity of 8.8 Mm^3 , what will be then the greatest output?

- 2 (a) Give the method of finding out the size of reservoir using stream flow records and demand.
(b) The following is a record of mean monthly discharges of a river in a dry year:

| <i>Month</i> | <i>Mean flow (cumec)</i> | <i>Month</i> | <i>Mean flow (cumec)</i> |
|--------------|------------------------------|--------------|------------------------------|
| April | 56.6 | Oct. | 161.5 |
| May | 62.2 | Nov. | 133.0 |
| June | 119.0 | Dec. | 190.0 |
| July | 258.0 | Jan. | 212.3 |
| Aug. | 234.0 | Feb. | 184.0 |
| Sept. | 201.5 | March | 127.5 |

The average net head available is 30.5 m and the average efficiency of a hydro-electric plant may be taken as 85%. Estimate the storage required to produce a firm power of 40 MW and the maximum firm power available.

- 3 The monthly inflow into a reservoir is as follows:

| <i>Month</i> | <i>Flow (Mm^3)</i> | <i>Month</i> | <i>Flow (Mm^3)</i> |
|--------------|--|--------------|--|
| Jan. | 340 | July | 400 |
| Feb. | 360 | Aug. | 300 |
| March | 300 | Sept. | 310 |
| April | 270 | Oct. | 330 |
| May | 240 | Nov. | 350 |
| June | 290 | Dec. | 320 |

The water turbines have an output of 22.5 MW working under a net head of 24 m and overall efficiency of 80%.

Determine the minimum capacity of the reservoir to satisfy the uniform demand for water and the total quantity of water wasted during the year assuming that at the beginning of January, the reservoir is full.

- 4 The quantity of water flowing in a river during each successive month is given below in Mm^3 .
4.2, 5.1, 8.5, 27.5, 45.3, 30.6, 14.2, 11.1, 10.2, 9.3, 8.8.

Determine the minimum capacity of a reservoir, if the above water is to be drawn off at a uniform rate and there should be no loss by flow over the spillway.

Also estimate the amount of water, which must be initially stored to maintain the uniform draw off.

Also calculate the electrical energy that could be generated per year, if the average available head is 36.5 m and the plant efficiency is 80%.

- 5 The following is a record of the power demand and of the streamflow taken in a day, for every 2-hr intervals (the record gives the average for the two hour periods).

| | <i>Time (hr)</i> | <i>Power demand (1000 kW)</i> | <i>Stream flow (cumec)</i> |
|-----|----------------------|-----------------------------------|--------------------------------|
| MN: | 0-2 | 11.4 | 59.5 |
| | 2-4 | 5.6 | 57.4 |
| | 4-6 | 25.6 | 55.2 |
| | 6-8 | 53.2 | 53.8 |
| | 8-10 | 44.8 | 52.4 |
| N: | 10-12 | 39.4 | 51.0 |
| | 12-14 | 44.2 | 49.6 |
| | 14-16 | 44.4 | 51.0 |
| | 16-18 | 74.2 | 52.4 |
| | 18-20 | 37.8 | 53.8 |
| | 20-22 | 30.0 | 55.2 |
| | 22-24 | 18.0 | 56.6 |

The average net head available is 109.3 m. The average plant efficiency is 85%. Determine the necessary storage, if the demand is to be just met.

- 6** Explain the significance of the terms; flow-duration curves, mass curves, pondage and storage. State the limiting conditions for economic storage and utilization of water resources in a country where the majority of rivers are not perennial?

Sketch one in which the power potential can be augmented further downstream.

- 7** Construct a mass curve from the following data of flow for a given site.

| <i>Weeks</i> | <i>Weekly flow (cumec)</i> |
|--------------|--------------------------------|
| 1-6 | 600 |
| 7-12 | 700 |
| 13-18 | 300 |
| 19-24 | 400 |
| 25-30 | 1700 |
| 31-36 | 1300 |
| 37-42 | 900 |
| 43-48 | 600 |
| 49-52 | 300 |

Estimate the size of reservoir and the possible maximum rate of flow that could be available from it. (5500 Mm³, 773 cumec)

- 8 The average weekly discharge as measured at a given site is as follows:

| <i>Week</i> | <i>Flow (cumec)</i> | <i>Week</i> | <i>Flow (cumec)</i> |
|-------------|-------------------------|-------------|-------------------------|
| 1 | 1000 | 14 | 1200 |
| 2 | 900 | 15 | 1000 |
| 3 | 909 | 16 | 900 |
| 4 | 800 | 17 | 800 |
| 5 | 800 | 18 | 500 |
| 6 | 600 | 19 | 400 |
| 7 | 500 | 20 | 400 |
| 8 | 500 | 21 | 300 |
| 9 | 800 | 22 | 300 |
| 10 | 800 | 23 | 400 |
| 11 | 1000 | 24 | 400 |
| 12 | 1100 | 25 | 500 |
| 13 | 1100 | 26 | 500 |

Plot

- (a) the hydrograph of weekly flow.
 (b) the flow-duration curve.
 (c) the power-duration curve if the head available is 50 m and the efficiency of the turbine-generator set is 85%.

Determine the power that can be developed per cumec, the maximum power, average power, and total energy produced during 26 weeks. (417 kW, 485 MW, 300 MW, 1.31 GWh)

- 9 Average daily flows in a river in typical low water week are given below. A run-of-river plant is proposed on this river to operate for 6 days in a week round the clock. The full pond effective head on turbines is 20 m and the plant efficiency is 80%. Maximum allowable fluctuation of pond level is 1 m.

Determine

- (i) the capacity of the pond required to give a maximum uniform output.
 (ii) the surface area of pond for satisfactory operation.
 (iii) the weekly energy output (KWH) from the plant.

| <i>Day:</i> | Sun. | Mon. | Tues. | Wed. | Thurs. | Fri. | Sat. |
|----------------------|------|------|-------|------|--------|------|------|
| <i>Flow (cumec):</i> | 26 | 35 | 40 | 50 | 45 | 40 | 30 |

- 10 Typical weekly and daily releases of water from an upstream reservoir on a river are given below. Estimate the pondage capacity to operate a run-of-river plant at downstream location so that a steady uniform power output is available from the plant.

Weekly release pattern

| <i>Day:</i> | Sun. | Mon. | Tues. | Wed. | Thurs. | Fri. | Sat. |
|--------------|------|------|-------|------|--------|------|------|
| <i>Flow:</i> | 25 | 30 | 40 | 50 | 40 | 35 | 25 |

release (cumec)

Daily release pattern

| | | | | |
|-------------------------------------|-----|------|-------|-------|
| <i>Time (hr):</i> | 0-6 | 6-12 | 12-18 | 18-24 |
| <i>% of ave. daily flow volume:</i> | 5 | 35 | 50 | 10 |

(**Hint** Pondage reqd. = weekly fluctuations + daily fluctuations)

- 11** During a low water week, the average daily flow in a river is 30 cumec and the pondage required for the daily fluctuation is about 20% of the average daily flow. A run-of-river plant to be located on the river is to operate 6 days a week, round the clock and is connected to a variable load with a daily load factor of 50%. The pondage required for the daily load fluctuation may be taken as about one-fifth of the mean flow to the turbine.

If the effective head on the turbine when the pond is full is 20 m and the maximum allowable fluctuation in pond level is 1 m, determine

(i) the capacity of the pond and its surface area.

(ii) the weekly energy output (KWH).

Assume a plant efficiency of 80%.

Chapter 11

RESERVOIR SEDIMENTATION

11.1 SEDIMENT MOVEMENT AND DEPOSITION

As the silt originates from the water shed, the characteristics of the catchment such its areal extent, soil types, land slopes, vegetal cover and climatic conditions like temperature, nature and intensity of rainfall, have a great significance in the sediment production in the form of sheet erosion, gully erosion and stream, channel erosion. In regions of moderate rainfall, *sheet erosion* is the dominant source of total sediment load while in arid and semi-arid regions, gullying and stream-channel erosion furnish the greater part of the load.

Experiments have shown that the erosive power of water, flowing with a velocity V , varies as V^2 while the transporting ability of water varies as V^6 . Sediment moves in the stream as suspended load (fine particles) in the flowing water, and as bed load (large particles), which slides or rolls along the channel bottom. Sometimes, the particles (small particles of sand and gravel) move by bouncing along the bed, which is termed as 'saltation', which is a transitional stage between bed and suspended load. The material, which moves as bed load at one section may be in suspension at another section.

The suspended sediment load of streams is measured by sampling the water, filtering to remove the sediment, drying and weighing the filtered material.

$$\text{Sediment load, (ppm)} = \frac{\text{weight of sediment in the sample}}{\text{weight of sediment laden water sample}} \times 10^6$$

The samplers may be of 'depth-integrating type' or 'point samplers'. Point samplers are used only where it is not possible to use the depth integrating type because of great depth of high velocity, or for studies of sediment distribution in streams. The sample is usually collected in 'pint bottle' held in a sample of stream-lined body so as not to disturb the flow while collecting a representative sample.

The relation between the suspended-sediment transport Q_s and stream flow Q is given by

$$Q_s = KQ^n \quad \dots(11.1)$$

$$\therefore \log Q_s = \log K + n \log Q \quad \dots(11.1 a)$$

and is often represented by a logarithmic plot of Q_s vs. Q (Fig. 11.1); $Q_s = K$ when $Q = 1$, and n is the slope of the straight line plot and ≈ 2 to 3.

The sediment rating curve from a continuous record of stream flow provides a rough estimate of sediment inflow to reservoirs and the total sediment transport may be estimated by adding 10-20% to the suspended sediment transport to allow for the bed load contribution.

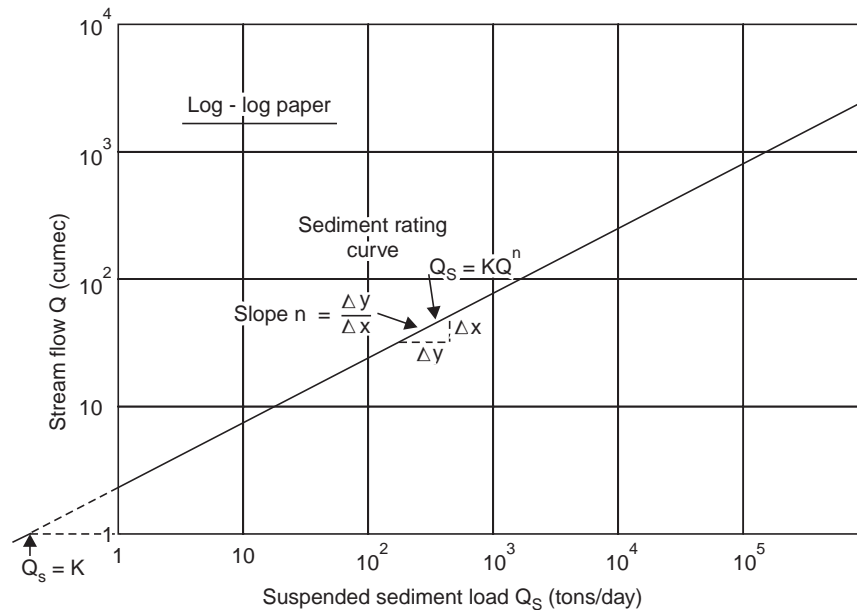

Fig. 11.1 Sediment rating curve

When the sediment-laden water reaches a reservoir, the velocity and turbulence are greatly reduced. The dense fluid-solid mixture along the bottom of the reservoir moves slowly in the form of a density current or stratified flows, *i.e.*, a diffused colloidal suspension having a density slightly different from that of the main body of reservoir water, due to dissolved minerals and temperature, and hence does not mix readily with the reservoir water (Fig. 11.2). Smaller particles may be deposited near the base of the dam. Some of the density currents and settled sediments near the base of the dam can possibly be flushed out by operating the sluice gates. The modern multipurpose reservoirs are operated at various water levels, which are significant in the deposition and movement of silt in the reservoir.

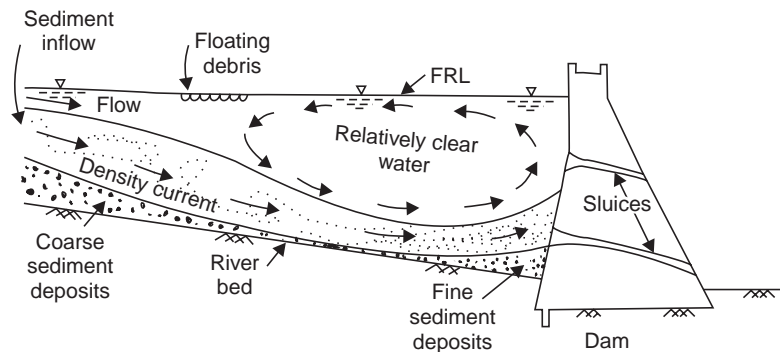

Fig. 11.2 Sediment accumulation in a reservoir

The total amount of sediment that passes any section of a stream is referred to as the *sediment yield* or *sediment production*. The mean annual sediment production rates generally range from 250-2000 tons/km² or 2.5-18 ha-m/100 km² and the Indian reservoirs are losing a storage capacity of 0.5-1% annually.

The following figures give a general idea of the silt carried by some of the big rivers in the world during floods:

| <i>River</i> | <i>Silt content (% by weight)</i> |
|----------------------------|-----------------------------------|
| Colorado (USA) | 1.00 |
| Mississippi-Missouri (USA) | 0.20 |
| Yangatze (China) | 0.04 |
| Yellow river (China) | 4.00 |
| Indus (Pakistan) | 0.42 |
| Sutlej (India) | 1.67 |
| Nile (Egypt) | 0.15 |
| Krishna (India) | 1.00 |
| Cauvery (India) | 0.14 |
| Tungabhadra (India) | 0.67 |
| Sone (India) | 0.56 |

The sedimentation rate worked out by experts for different projects in India are given below:

| <i>Project</i> | <i>Annual sedimentation rate (ham/100 km²)</i> |
|----------------|---|
| Bhakra | 6.00 |
| Hirakund | 3.89 |
| Gandhisagar | 10.05 |
| Nizamsagar | 6.57 |
| Panchet | 9.92 |
| Maithon | 13.02 |
| Ramganga | 17.30 |
| Tungabhadra | 6.00 |
| Mayurakshi | 20.09 |
| Tawa | 8.10 |
| Dantiwada | 6.32 |
| Manchkund | 2.33 |

11.2 REDUCTION IN RESERVOIR CAPACITY

The useful life of a reservoir gets reduced due to sediment deposition causing a decrease in its storage capacity. The factors affecting the pattern of sediment deposition in reservoirs are:

- (i) sediment load (*i.e.*, sediment inflow rate)
- (ii) sediment size (*i.e.*, gradation of silt)
- (iii) compaction of sediment
- (iv) river inflow pattern
- (v) river valley slope
- (vi) shape of reservoir
- (vii) capacity of reservoir (its size and storage period)

- (viii) vegetal growth at the head
- (ix) outlets in the dam (their types, location and size)
- (x) reservoir operation
- (xi) upstream reservoirs, if any.

It has been found by experience that a low sediment inflow rate, large fraction of fine particles, steep slope, no vegetation at head of reservoir, low flow detention time in the reservoir (by operation of outlets of suitable size at different levels), possibly series of upper tanks or reservoir upstream (where deposition occurs) do not favour sediment deposition and compaction. The silt carried in the rainy season may be excluded from the reservoir by means of scouring sluices slightly above the deep river-bed, which discharge the heavily silt-laden water at high velocity. The percent of the inflowing sediment, which is retained in a reservoir is called the *trap efficiency* and it is a function of the ratio of reservoir capacity to total annual sediment inflow, since a small reservoir on a large stream passes most of its inflow quickly (giving no time for the silt to settle) while a large reservoir allows more detention time for the suspended silt to settle. The relation between trap efficiency of reservoir vs. capacity-inflow ratio is shown in Fig. 11.3 (Brune, 1953), on the basis of data from surveys of existing reservoirs. The rate at which the capacity of a reservoir is reduced by sediment deposition depends on

- (i) the rate of sediment inflow, *i.e.*, sediment load.
- (ii) the percentage of the sediment inflow trapped in the reservoir, *i.e.*, trap efficiency.
- (iii) the density of the deposited sediment.

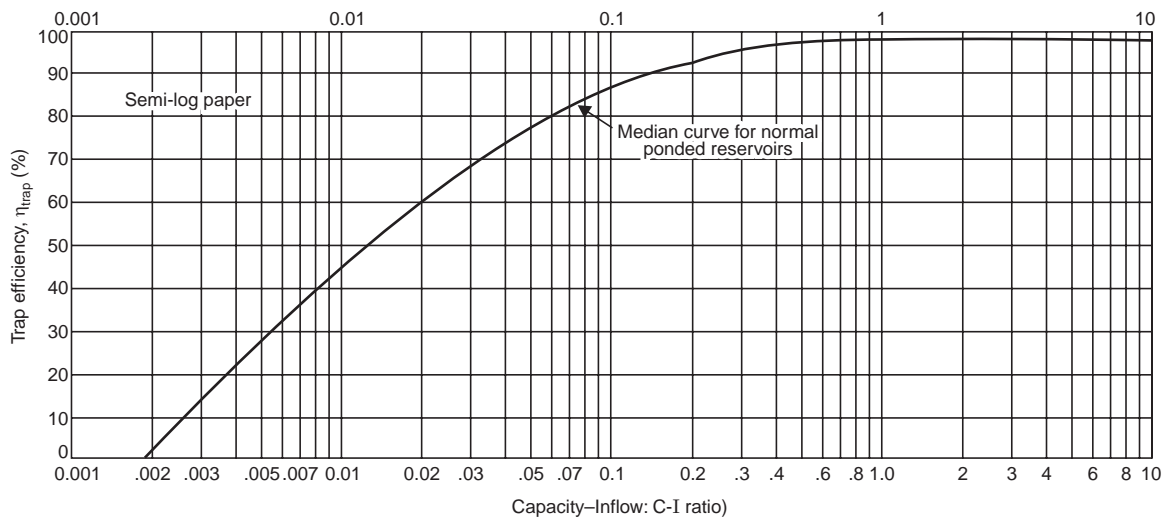

Fig. 11.3 Reservoir trap efficiency vs. capacity-inflow ratio (after Brune, 1953)

In estimating the useful life of a reservoir, the correct prediction of the density of the deposited sediment is an important factor. Lane and Koelzer (1943) gave the equation for the dry specific weight γ_t after time t years as

$$\gamma_t = \gamma_i + K \log_{10} t \quad \dots(11.2)$$

where γ_i = initial specific weight

K = a constant for the rate of compaction

If the deposited sediment consists of a mixture of materials like sand, silt and clay, a weighted average specific weight is calculated as (Lane and Koelzer).

$$\gamma_t = \gamma_1 x_1 + (\gamma_2 + K_2 \log t) x_2 + (\gamma_3 + K_3 \log t) x_3 \quad \dots(11.2 a)$$

where γ_t = average specific weight of reservoir sediment after t years

$\gamma_{1,2,3}$ = specific weight of sand, silt and clay after t years

$K_{1,2,3}$ = constant for the rate of compaction of sand, silt and clay, respectively ($K_1 \approx 0$, for sand)

$x_{1,2,3}$ = fractional part of total sediment, of sand, silt and clay, respectively

t = time in years (≥ 1 yr)

The useful capacity of reservoir lost each year by sediment deposition is

$$V_s = Q_s \eta_{\text{trap}} \quad \dots(11.3)$$

where V_s = volume of useful capacity of reservoir lost each year

Q_s = annual sediment inflow into the reservoir

η_{trap} = trap efficiency of the reservoir

while allocating space for the dead storage in the reservoirs (*i.e.*, to provide space for sediment deposition during the life of the project) the trap efficiency is taken as at least 95% and rarely below 90%. Sediment deposits in the upper end of the reservoirs generally become covered by vegetation resulting in heavy evapotranspiration loss of the available water, which is more critical in arid regions.

Example 11.1 A proposed reservoir has a capacity of 400 ha-m. The catchment area is 130 km² and the annual stream flow averages 12.31 cm of runoff. If the annual sediment production is 0.03 ha-m/km², what is the probable life of the reservoir before its capacity is reduced to 20% of its initial capacity by sediment deposition. The relation between trap efficiency and capacity-inflow ratio is given below.

| Capacity-inflow ratio, $\frac{C}{I}$ | Trap efficiency, η_{trap} (%) | Capacity-inflow ratio, $\frac{C}{I}$ | Trap efficiency, η_{trap} (%) |
|---|---|---|---|
| 0.1 | 87 | 0.002 | 2 |
| 0.2 | 93 | 0.003 | 13 |
| 0.3 | 95 | 0.004 | 20 |
| 0.4 | 95.5 | 0.005 | 27 |
| 0.5 | 96 | 0.006 | 31 |
| 0.6 | 96.5 | 0.007 | 36 |
| 0.7 | 97 | 0.008 | 38 |
| 1.0 | 97.5 | 0.01 | 43 |
| | | 0.015 | 52 |
| | | 0.02 | 60 |
| | | 0.03 | 68 |
| | | 0.04 | 74 |
| | | 0.05 | 77 |
| | | 0.06 | 80 |
| | | 0.07 | 82 |

Solution The useful life may be computed by determining the number of years required for each incremental loss of reservoir capacity (*i.e.*, for the decreasing values of capacity-inflow ratios) upto the critical storage volume of $400 \times 0.20 = 80$ ha-m as tabulated below:

| Capacity C (ha-m) | Capacity* inflow ratio $\frac{C}{I}$ | Trap efficiency η_{trap} (%) | | Annual** sediment trapped $V_s = Q_s \times \eta_{trap}$ | Loss of reservoir capacity ΔC (ha-m) | No. of years for the capacity loss $\Delta C \div V_s$ |
|---------------------------|---|--------------------------------------|------------------------|---|--|--|
| | | for the $\frac{C}{I}$ ratio | Ave. for *increment | | | |
| 400 | 0.25 | 94 | | | | |
| 320 | 0.20 | 93 | 93.5 | 3.64 | 80 | 22.0 |
| 240 | 0.15 | 90 | 91.5 | 3.57 | 80 | 22.4 |
| 160 | 0.10 | 87 | 88.5 | 3.45 | 80 | 23.2 |
| 80 | 0.05 | 77 | 82.0 | 3.20 | 80 | 25.0 |
| | | | | | | Total = 92.6 say, 93 yr |

$$* \text{Average annual inflow, } I = \frac{12.31}{100} \times \frac{130 \times 10^6}{10^4} = 1600 \text{ ha-m}$$

$$\text{For reservoir capacity } C = 400 \text{ ha-m, } \frac{C}{I} = \frac{400}{1600} = 0.25$$

**Annual sediment inflow into the reservoir

$$Q_s = 0.03 \times 130 = 3.9 \text{ ha-m}$$

Note: If the average annual sediment inflow Q_s is given in tons, say $Q_s = 43600$ tons and for $\eta_{trap} = 93.5\%$ (for the first incremental loss), assuming a specific gravity of 1.12 for the sediment deposits, annual sediment trapped $W_s = 43600 \times 0.935 = 40750$ tons.

$$V_s = \frac{W_s}{\gamma_s} = \frac{40750 \times 1000 \text{ kg}}{1.12 \times 1000 \text{ kg/m}^3} = \frac{40750}{1.12} \text{ m}^3 = 3.64 \text{ ha-m.}$$

Usually the specific gravity of sediments deposits ranges from 1 to 1.4.

11.3 RESERVOIR SEDIMENTATION CONTROL

Sediment deposition in reservoirs can not be actually prevented but it can be retarded by adopting some of the following measures:

- (i) Reservoir sites, which are prolific sources of sediment should be avoided.
- (ii) By adopting soil-conservation measures in the catchment area, as the silt originates in the watershed. See art 8.7 in Chapter 8.
- (iii) Agronomic soil conservation practices like cover cropping, strip cropping, contour farming, suitable crop rotations, application of green manure (mulching), proper control over graze lands, terracing and benching on steep hill slopes, etc. retard overland flow, increase infiltration and reduce erosion.

(iv) Contour trenching and afforestation on hill slopes, contour bunding gully plugging by check dams, and stream bank stabilisation by the use of spurs, rivetments, vegetation, etc. are some of the engineering measures of soil conservation.

(v) Vegetal cover on the land reduces the impact force of rain drops and minimises erosion.

(vi) Sluice gates provided in the dam at various levels and reservoir operation, permit the discharge of fine sediments without giving them time to settle to the bottom.

(vii) Sediment deposits in tanks and small reservoirs may be removed by excavation, dredging, draining and flushing either by mechanical or hydraulic methods and sometimes may have some sales value.

QUIZ XI

I Match the items in 'A' with the items in 'B'

| A | B |
|--|---------------------------|
| (i) Gullying and stream Channel erosion | (a) V^6 |
| (ii) Measurement of suspended sediment | (b) V^2 |
| (iii) Erosive power of water | (c) Capacity-inflow ratio |
| (iv) Transporting capacity of water | (d) Soil conservation |
| (v) Saltation | (e) Bouncing along bed |
| (vi) Trap efficiency | (f) Semi-arid regions |
| (vii) Sedimentation control | (g) Point samplers |

II Say 'true' or 'false'; if false, give the correct statement:

- (i) While sheet erosion is dominant in regions of moderate rainfall, gullying and stream channel erosion are characteristic of arid and semi-arid regions.
- (ii) Density current is a stratified flow along the bottom of the reservoir and mixes readily with the reservoir water.
- (iii) The per cent of the inflowing sediment in a stream retained by a reservoir is called the *trap efficiency* of the reservoir.
- (iv) The trap efficiency of a reservoir is a function of the ratio of the reservoir capacity to the average annual sediment inflow, and as this ratio decreases the trap efficiency increases.
- (v) Silting of reservoirs can be controlled by
 - (a) proper agronomic practices.
 - (b) adopting soil-conservation measures.
 - (c) by providing sluice gates at various levels in the dam and proper reservoir operation.

(false: ii, iv)

III Choose the correct statement/s:

- Siltation of reservoir can be reduced by
- (i) proper reservoir operation.
 - (ii) providing sluice gates at different levels.
 - (iii) land management.

- (iv) gully plugging, check dams and contour bunds in the catchment area.
 (v) strip cropping, contour farming and afforestation of hill slopes.
 (vi) providing dead storage.
 (vii) all the above steps. (except vi)

QUESTIONS

- 1 (a) What are the factors which contribute for silt in a natural stream?
 (b) How will you determine the quantity of silt deposited in a reservoir?
 (c) Recommend the measures for controlling the silt entry into reservoirs.
- 2 (a) How would you determine the sediment load carried by a stream?
 (b) What do you understand by density current?
 (c) Explain the terms:

| | |
|----------------|---------------------|
| (i) Saltation | (ii) Suspended load |
| (iii) Bed load | (iv) Contact load |
- 3 (a) Briefly give the theory of distribution and transportation of suspended material and derive the formula connecting the concentration of sediment and settling velocity under equilibrium conditions.
 (b) Explain how sedimentation in a reservoir can be controlled.
 (**Hint:** for Q 3 (a) supplementary reading)
- 4 (a) Describe a method by which silt accumulation in a reservoir can be computed and its useful life determined.
 (b) An impounding reservoir had an original storage capacity of 740 ha-m. The catchment area of the reservoir is 100 km², from which the annual sediment discharge into the reservoir is at the rate 0.1 ha-m/km². Assuming a trap efficiency of 80%, find the annual capacity loss of the reservoir in percent per year. (1.3%/year)
- 5 A proposed reservoir has a capacity of 600 ha-m. The catchment area is 147 km² and the annual streamflow averages 17 cm of runoff. If the annual sediment production is 0.035 ha-m/km² what is the probable life of the reservoir before its capacity is reduced to 20% of its initial capacity by sediment deposition. The relation between trap efficiency and capacity-inflow ratio is given below:

| $\frac{\text{Capacity}}{\text{Inflow}}$ ratio | Trap efficiency (%) | $\frac{\text{Capacity}}{\text{Inflow}}$ ratio | Trap efficiency (%) |
|---|---------------------|---|---------------------|
| 0.1 | 87 | 0.01 | 43 |
| 0.2 | 93 | 0.02 | 60 |
| 0.3 | 95 | 0.03 | 68 |
| 0.4 | 95.5 | 0.05 | 77 |
| 0.5 | 96.0 | 0.07 | 82 |
| 0.6 | 96.5 | | |
| 0.7 | 97 | | |
| 1.0 | 97.5 | | |

(97 yr)

Chapter 12

ARID, SEMI-ARID AND HUMID REGIONS

Climates can be classified on the basis of temperature, barometric pressure, humidity, sunshine, evaporation, rainfall and prevailing winds in a particular place or region. From the viewpoint of irrigation, the classification based on rainfall is reasonable, *i.e.*, if

- a.a.r. < 40 cm —arid climate
- a.a.r. = 40–75 cm —semi-arid climate
- a.a.r. > 75 cm —humid climate

We have all the three classes of climatic zones (regions) in India and the hydro meteorological processes peculiar to each climate have to be studied in detail for optimum water resources utilisation and irrigation (crop) planning or agricultural practice. Some of the characteristic features of each type of climatic region are enumerated below:

12.1 ARID REGIONS

(i) a.a.r. < 40 cm; a drought is a normal state of affairs, and while calculating runoff each fall of rain has to be considered as a separate unit.

(ii) A little rainfall occurs once in a while with a wide variability with respect to time and space.

(iii) A very high temperature and hot climate; there is scarcity of water; unfit for irrigation and no regular crops can be grown.

(iv) Evaporation losses are very high. Any slight precipitation will be lost by evaporation; water has to be applied to crops by special methods like ‘drip’ and ‘sprinkler irrigation’; salt-concentration problems occur in irrigated soils near root zones.

(v) Rainfall is mostly during summer and is given by

$$R < (T + 14)$$

where R = annual rainfall in cm

T = average annual temperature in °C

The arid zone of Rajasthan receives ≈ 40 cm of rainfall per year.

(vi) Streams carry only surface runoff and flow immediately following periods of intense rainfall; hence, they are intermittent.

(vii) The ground water table if at all exists, is very deep and is always below the bed of the stream; most of the streams are ephemeral.

(viii) The infiltration capacity of the soil is nearly constant throughout the year. All the infiltration may be considered as a water loss and the water once infiltrated never reaches the stream draining the basin nor the ground water storage has any significance.

(ix) From the records of a number of intense storms and their hydrographs of surface runoff, the average infiltration capacity of a basin can be determined. This average value can be applied to each intense storm and the resulting runoff can be found.

(x) Afforestation provides a mechanical obstacle to the free sweep of wind, reducing in the process the wind velocity, soil erosion and evaporation from soil.

(xi) Sand dune stabilisation is considered an important work in the arid regions of Rajasthan, as sand dunes with varying frequency are spread over 58% of the arid zone of Rajasthan. The Central Arid Zone Research Institute (CAZRI) at Jodhpur has directed its efforts towards control of desertification through afforestation and sand dune stabilisation (since wind-swept sand from deserts can bury anything coming in the way).

(xii) *Reduction in grazing land*—In the arid parts, like those of Rajasthan, the population density is 48 persons per km² compared to 3 per km² in most other deserts of the world. Along with the rise in the human population, the livestock population too is on the increase (\approx 200 per ha). The result has been over use of the grazing land and depletion of natural vegetation resources. More and more marginal land is being brought under the plough, reducing the area of grazing land, trees and shrubs. The increase in rainfed farming on marginal lands has not only resulted in decline in crop productivity per unit area, but also enhanced soil erosion, degraded soil fertility and led to over-exploitation of ground waters. The CAZRI's efforts are to be viewed against this background.

(xiii) *Exotic species*—The CAZRI has shown that about 25% of the area now under cultivation should be brought under cover of grass and trees. CAZRI has focussed its efforts on the introduction of exotic fast-growing tree and shrub species from iso-climatic regions of the world. The species *Acacia Tortilis* (Israeli Babool) has been found to be the best fuel-cum-fodder species for dry zones. *Ber* is one of the main fruit plants of the region and CAZRI has developed the technology to cut short the time required to raise a *Ber Orchard* from the normal one year to just four months.

The grafted plants of improved varieties are raised in polythene tubes. To make it popular, a programme of budding of two improved varieties on the root stock of the common local bush has been undertaken.

12.2 SEMI-ARID REGIONS

(i) The a.a.r. = 40 to 75 cm; a semi-arid region usually receives precipitation during winter and spring.

(ii) Rainfall occurs during a particular season of the year and it may be virtually non-existent in other parts of the year.

(iii) Only during the rainy season, the stream flow is continuous; during the dry season the stream becomes dry most of the time and carries water intermittently after an occasional heavy storm. The stream flows are usually of too short duration to develop a stable channel section and occasional high flood flows may change the cross-section radically.

(iv) Moderate precipitation and temperature higher than normal. The usual methods of determining mean precipitation by constructing Thiessen Polygons or by arithmetic mean are impracticable. Isohyetal maps should be used as the precipitation varies with time and area.

Average elevation-precipitation curves from precipitation data will be more useful for semi-arid regions.

$$R \text{ lies between } (T + 14) \text{ and } 2(T + 14) \quad \dots(12.2)$$

where R = annual rainfall in cm

T = annual average temperature in °C

(v) Major loss of water is by evapotranspiration and the evapotranspiration losses range from 40 cm/year for barren rocky areas to 90 cm/year for heavy forest areas.

(vi) The ground water table occurs at moderate depth.

(vii) Wide variability of hydrologic factors with respect to time and space are a characteristic feature; for example, vegetative cover may vary radically across a basin—thick vegetation in higher altitudes and barren land in lower reaches.

A high elevation zone of a river basin may get precipitation regularly while other parts of the basin may not get; 90% of runoff may result from 10% of the drainage area. Runoff values expressed as flow per km² of drainage area may be inapplicable.

Hydrologic factors occurring in one season may be virtually non-existent during another season.

As geology of the basin differs from place to place, the infiltration rate too differs.

(viii) Seasonal crops like jowar, ragi etc. can be grown.

(ix) Probability and duration studies (flow duration, drought duration) are essential to determine the available flow or drought period in a long term climatological cycle (or swing).

(x) A drought occurs at least once in a year except in abnormal years,

(xi) Even in a single river basin, the hydrological processes in semi-arid regions differ from area to area.

(xii) *Mean depth of precipitation.* In semi-arid regions where the precipitation is controlled by the topography, the pattern of rainfall distribution can be studied by 'isopercentral map'. Such maps should be prepared for individual and isolated storms. By adopting isoper-central method, a comparatively small number of stations can be used to develop a quite detailed isohyetal map. This method of finding the mean precipitation over the basin will avoid errors caused by imperfect distribution of rain gauge stations.

Because of the characteristic variability of precipitation in semi-arid mountainous regions, direct transposition of either isohyetal pattern or depth-area values from one river basin to another may lead to quite unreasonable results.

(xiii) The unit hydrograph technique can not be used in semi-arid regions, as it requires constancy of hydrologic factors over a river basin.

(xiv) *Semi-arid and desert regions of Rajasthan.* Rajasthan (*n-w* India) has a total area of ≈ 330000 km², which is sandy and unproductive with scanty rainfall and very low water table. About 90% of the rainfall occurs during the monsoon period, June to September. The evaporation is very high of the order of 300 cm and much of the rainfall is quickly evaporated, though some portion of it sinks into the earth to replenish the ground water.

The conditions in the semi-arid regions are better than the desert lands. Some portion, particularly the Luni basin, can probably be improved if suitable conservation, storage and irrigation methods are adopted. For planning the reclamation of the desert and semi-desert regions of Rajasthan, it is necessary to have proper study of meteorological conditions based on detailed observations of rainfall, evaporation, humidity and other meteorological elements.

(xv) *Silting*. While sheet erosion is dominant in regions of moderate rainfall, gullying and stream channel erosion are characteristic of arid and semi-arid regions. Sediment deposits in the upper end of reservoirs generally become covered by vegetation resulting in heavy evapotranspiration loss of the available water, which is more critical in arid regions.

12.3 HUMID REGIONS

(i) High intensity of rainfall (a.a.r. > 75 cm) with not much variability with respect to time and space.

(ii) High precipitation, low temperature and minimum loss of water. Transpiration is the major water loss amounting upto 80%.

(iii) Flow in streams is continuous and the ground water table is always above the bed level of the stream, *i.e.*, the streams are mostly perennial.

(iv) The ground water table is usually at very high elevation and the ground water contributes to streamflow. The change in ground water storage becomes significant.

(v) Average annual yield can be satisfactorily determined from a comparatively short period of records.

(vi) Best suited for irrigation and agriculture. Crops can be grown throughout the year due to availability of water supply throughout.

(vii) A drought does not occur in ordinary years.

QUIZ XII

I Choose the correct statement/s in the following:

1 In an arid region

- | | |
|--|---|
| (i) rainfall is mostly during summer | (ii) each fall of rain is considered as a separate unit |
| (iii) drought-duration studies are essential | (iv) major loss is by transpiration |
| (v) 'drip irrigation' is preferred | (vi) ephemeral streams are common |
| (vii) seasonal crops can be grown | (viii) all the above characteristics |

2 In a semi-arid region

- (i) precipitation is only during winter or spring
- (ii) rainfall is only seasonal
- (iii) Intermittent streams are common
- (iv) 'isopercental maps' are prepared for individual or isolated storms
- (v) seasonal crops like jowar, ragi, etc. can be grown
- (vi) flow-duration and drought-duration studies are essential
- (vii) Unit hydrograph method can be applied
- (viii) Gullying and stream-channel erosion is a characteristic feature
- (ix) all the above characteristics

3 In a humid region

- | | |
|-------------------------------------|--|
| (i) uniformly high rainfall occurs | (ii) transpiration is the major water loss |
| (iii) streams are mostly perennial | (iv) intensive irrigation is possible |
| (v) drought normally does not occur | (vi) change in ground water storage is significant |

(vii) high evaporation losses occur

(viii) all the above characteristics.

[1—(v), (vi); 2—except (vii); 3—except (vii)]

II Match the items in 'A' with items in 'B' (more than one item in 'B' may fit):

A

- (i) Semi-arid region
- (ii) Arid region
- (iii) Drip irrigation
- (iv) Seasonal crops
- (v) Probability and duration studies
- (vi) Humid region

B

- (a) Arid region
- (b) Semi-arid region
- (c) Normally drought conditions
- (d) Transpiration—major water loss
- (e) GWT very high
- (f) High temperature
- (g) Low temperature
- (h) Isopercentral map
- (i) Ephemeral streams
- (j) High evaporation losses
- (k) a.a.r. = 40–75 cm
- (l) a.a.r. < 40 cm

III Say 'true' or 'false', if false, give the correct statement:

- (i) High evaporation losses are significant in arid regions while transpiration is the major water loss in humid regions.
- (ii) In arid regions, the rainfall occurs mostly during summer and the rainfall (R) in cm is given by: $R = T + 14$, while in semi-arid regions, the rainfall is mostly during winter and spring and R lies between $(T + 14)$ and $2(T + 14)$, where T is the annual average temperature in °C.
- (iii) In arid regions, the infiltration capacity of the soil varies throughout the year.
- (iv) Ephemeral streams are quite common in semi-arid regions.
- (v) Salt-concentration problems occur in irrigated soils and hence water has to be applied to crops by 'drip' or 'sprinkler irrigation' methods, in arid regions.
- (vi) Seasonal crops like jowar, ragi, etc., can not be grown in semi-arid regions.
- (vii) Probability and duration studies (drought duration and flow duration) are essential to determine the available flow or drought period in a long-term climatological cycle (or swing) in arid and semi-arid regions.
- (viii) Non-variability of hydrological factors with respect to time and space are characteristic features of arid and semi-arid regions.
- (ix) In arid regions, the pattern of rainfall distribution (development of isohyetal map) can be studied by 'isopercentral map'.
- (x) Transposition of either the isohyetal pattern or depth-area values from one river basin to another may give erroneous results in semi-arid mountainous regions.
- (xi) Unit hydrograph technique can be used for semi-arid regions.
- (xii) High precipitation (a.a.r. > 75 cm) and low temperature are characteristic of humid regions and crops can be grown throughout the year.
- (xiii) While drought is a usual state of affairs in an arid region, it does not occur in ordinary years in a humid region.
- (xiv) A drought occurs at least once in a year in a semi-arid region, except in abnormal years.

(false: iii, iv, vi, viii, ix, xi)

QUESTIONS

- 1 Discuss the hydrological processes peculiar to arid and semi-arid regions. Explain the method of computing mean depth of precipitation in semi-arid zones.
- 2 (a) Explain 'arid and semi-arid regions'.
(b) Explain briefly the surface-drainage characteristics that are peculiar to arid and semi-arid regions.
(c) What parts of India can be classified as semi-arid?

**THIS PAGE IS
BLANK**

PART B

ADVANCED TOPICS

**THIS PAGE IS
BLANK**

Chapter 13

LINEAR REGRESSION

13.1 FITTING REGRESSION EQUATION

The fitting of a straight line may be done objectively by one of the following statistical methods:

- (a) The method of least squares
- (b) The method of moments
- (c) The method of maximum likelihood

In this chapter, the method of least squares is used. Two variables y (dependent) and x (independent) can be correlated by plotting them on x - and y -axis. If they are plotted on a straight line, there is a close linear relationship; on the other hand, if the points depart appreciably (without a definite trend), the graph is called a *scatter diagram* or plot.

If the trend is a straight line, the relationship is linear and has the equation

$$y = a + bx \quad \dots(13.1)$$

Number of lines can be obtained depending on the values of a and b . The method of least squares is used to select the line that fits the data best. The principle of least squares states that the best line for fitting a series of observations is the one for which the sum of the squares of the departures is minimum. A departure is the difference between the observed value and the line. Since x is the independent variable, the departures of y are used.

The least squares line Eq. (13.1) may be obtained by solving for a and b , the two normal equations

$$\begin{aligned} \Sigma y &= na + b \Sigma x \\ \Sigma xy &= a \Sigma x + b \Sigma x^2 \end{aligned} \quad \dots(13.2)$$

where n = number of pairs of observed values of x and y .

The most commonly used statistical parameter for measuring the degree of association of two linearly dependent variables x and y , is the correlation coefficient

$$r = \frac{\Sigma(\Delta x \cdot \Delta y)}{\sqrt{\Sigma(\Delta x)^2 \cdot \Sigma(\Delta y)^2}} \quad \dots(13.3)$$

$$= \frac{\Sigma xy - n\bar{x}\bar{y}}{(n-1)\sigma_x\sigma_y} \quad \dots(13.3 a)$$

where $\Delta x = x - \bar{x}$, $\Delta y = y - \bar{y}$

σ_x, σ_y = standard deviations of x and y , respectively

x, y = middle of each class interval, respectively

If $r = 1$, the correlation is perfect giving a straight line plot (regression line).

$r = 0$, no relation exists between x and y (scatter plot).

$r \rightarrow 1$, indicates a close linear relationship.

If a linear regression can not be fitted, a quadratic parabola can be used as the fitting curve, given by

$$y = a + bx + cx^2 \quad \dots(13.4)$$

From the principles of least squares, a , b and c can be obtained by solving the three normal equations

$$\begin{aligned} \Sigma y &= na + b\Sigma x + c \Sigma x^2 \\ \Sigma xy &= a\Sigma x + b \Sigma x^2 + c \Sigma x^3 \\ \Sigma x^2y &= a\Sigma x^2 + b \Sigma x^3 + c \Sigma x^4 \end{aligned} \quad \dots(13.5)$$

where n = number of pairs of observed values of x and y .

Regardless of the type of curve fitted, the correlation coefficient r is given by Eq. (13.3). The variables x and y , for instance, may be precipitation and the corresponding runoff, or gauge height and the corresponding stream flow, and like that.

$$\text{For the exponential function } y = cx^m \quad \dots(13.6)$$

it can be transformed to a straight line by using logarithms of the variables as

$$\log y = \log c + m \log x \quad \dots(13.7)$$

By putting $\log x = X$, $\log y = Y$, $\log c = a$ and $m = b$ the function becomes similar to Eq. (13.1), can be solved for a and b from Eq. (13.2) and the exponential function can be determined.

Whichever fitting gives $r \rightarrow 1$ by Eq. (13.3), that curve fitting is adopted. Statistical method can be applied to many kinds of meteorological data, such as precipitation, temperature, floods, droughts, and water quality.

13.2 STANDARD ERROR OF ESTIMATE

A measure of the scatter about the regression line of y on x in Eq. (13.1) is given by

$$S_{y.x} = \sqrt{\frac{\Sigma(y - y_{est})^2}{n - 2}} \quad \dots(13.8)$$

which is called the *standard error* of estimate of y with respect to x ; and y_{est} is the value of y for the given value of x in Eq. (13.1). $S_{y.x}$ can also be determined by the expressions

$$S_{y.x} = \sigma_y \sqrt{1 - r^2} \quad \dots(13.9)$$

$$S_{y.x} = \sqrt{\frac{\Sigma y^2 - a\Sigma y - b \Sigma xy}{n - 2}} \quad \dots(13.10)$$

$$S_{y.x} = \sqrt{\frac{n - 1}{n - 2} (\sigma_y^2 - b^2 \sigma_x^2)} \quad \dots(13.11)$$

Eq. (13.10) can be extended to non-linear regression equations.

Example 13.1 Annual rainfall and runoff data for the Damodar river at Rhondia (east India) for 17 years (1934-1950) are given below. Determine the linear regression line between rainfall and runoff, the correlation coefficient and the standard error of estimate.

| Year | Rain fall (mm) | Runoff (mm) |
|------|-------------------|----------------|
| 1934 | 1088 | 274 |
| 35 | 1113 | 320 |
| 36 | 1512 | 543 |
| 37 | 1343 | 437 |
| 38 | 1103 | 352 |
| 39 | 1490 | 617 |
| 40 | 1100 | 328 |
| 41 | 1433 | 582 |
| 42 | 1475 | 763 |
| 43 | 1380 | 558 |
| 44 | 1178 | 492 |
| 45 | 1223 | 478 |
| 46 | 1440 | 783 |
| 47 | 1165 | 551 |
| 48 | 1271 | 565 |
| 49 | 1443 | 720 |
| 1950 | 1340 | 730 |

Solution The regression line computations are made in Table 13.1 and is given by

$$R = 0.86 P - 581$$

where P = rainfall (mm) and R = runoff (mm)

The correlation coefficient $r = 0.835$, which indicates a close linear relation and the straight line plot is shown in Fig. 13.1, the relation is very close.

Standard error of estimate

$$S_{y.x} = \sigma_y \sqrt{1 - r^2}$$

$$\sigma_y = \sqrt{\frac{\Sigma(y - \bar{y})^2}{n - 1}} = \sqrt{\frac{\Sigma(\Delta y)^2}{n - 1}} = \sqrt{\frac{40.10 \times 10^4}{17 - 1}} = 160 \text{ mm}$$

$$\therefore S_{y.x} = 160 \sqrt{1 - (0.835)^2} = \mathbf{90.24 \text{ mm}}$$

As an assignment problem, the relation between the staff gauge reading (water stage) 'h' and the stream discharge 'Q', for the stage-discharge data given in Example 6.2 may be established by the method of least squares.

Table 13.1 Regression line for the Rainfall-runoff data for river Damodar (1934-1950). (Example 13.1)

| Rainfall (mm) x | Runoff (mm) y | $x^2 \times 10^4$ | $xy \times 10^4$ | $\Delta x = x - \bar{x}$ | $\Delta y = y - \bar{y}$ | $(\Delta x)^2 \times 10^4$ | $(\Delta y)^2 \times 10^4$ | $\Delta x \cdot \Delta y \times 10^4$ | Working |
|----------------------|--------------------|--------------------|----------------------|--------------------------|--------------------------|----------------------------|----------------------------|---------------------------------------|---|
| 1088 | 274 | 118.4 | 29.8 | -212 | -261 | 4.50 | 6.81 | 5.54 | $\bar{x} = \frac{\Sigma x}{n} = \frac{22097}{17} = 1300$ mm |
| 1113 | 320 | 124.0 | 35.6 | -187 | -215 | 3.50 | 4.63 | 4.02 | $\bar{y} = \frac{\Sigma y}{n} = \frac{9093}{17} = 535$ mm |
| 1512 | 543 | 229.0 | 82.2 | +212 | +8 | 4.50 | 0.01 | 0.17 | Normal equations:* Eqs. (13.2) |
| 1343 | 437 | 180.2 | 58.8 | +43 | -98 | 0.18 | 0.96 | 0.42 | 9093 = 17 a + 22097 b (i) |
| 1103 | 352 | 122.0 | 38.9 | -197 | -183 | 3.88 | 3.35 | 3.61 | 1213.3 $\times 10^4 = 22097 a$ |
| 1490 | 617 | 222.0 | 92.0 | +190 | +82 | 3.62 | 0.67 | 1.56 | Dividing throughout by 10^4 , |
| 1100 | 328 | 121.0 | 36.0 | -200 | -207 | 4.00 | 4.28 | 4.14 | 1213 = 2.2 a + 2910 b (ii) |
| 1433 | 582 | 205.0 | 83.5 | +133 | +47 | 1.77 | 0.22 | 0.65 | Solving (i) and (ii) |
| 1475 | 763 | 217.0 | 112.6 | +175 | +228 | 3.06 | 5.10 | 3.99 | $a = -581, b = 0.86$ |
| 1380 | 558 | 190.5 | 77.0 | +80 | +23 | 0.64 | 0.05 | 0.18 | \therefore Regression line is |
| 1178 | 492 | 138.6 | 57.8 | -122 | -43 | 1.49 | 0.19 | 0.52 | $y = 0.86x - 581$ |
| 1223 | 478 | 149.8 | 58.5 | -77 | -57 | 0.59 | 0.33 | 0.44 | or $R = 0.86P - 581$ |
| 1140 | 783 | 207.0 | 112.8 | +140 | +248 | 1.96 | 6.15 | 3.48 | where R and P are in mm |
| 1165 | 551 | 136.0 | 64.2 | -135 | +16 | 1.82 | 0.03 | 0.22 | |
| 1271 | 565 | 162.0 | 71.8 | -29 | +30 | 0.08 | 0.09 | 0.09 | |
| 1443 | 720 | 208.0 | 104.0 | +143 | +185 | 2.05 | 3.43 | 2.65 | |
| 1340 | 730 | 179.5 | 97.8 | +40 | +195 | 0.16 | 3.80 | 0.78 | |
| $\Sigma = 22097$ | 9093 | 2910×10^4 | 1213.3×10^4 | | | 37.81×10^4 | 40.09×10^4 | 32.46×10^4 | |

*Matrix form for computer solution of Eqs. (13.2):

$$y = a + bx \quad \dots \text{Eqn. (13.1)}$$

$$\begin{bmatrix} \Sigma i \\ \Sigma x \end{bmatrix} \begin{bmatrix} a \\ b \end{bmatrix} = \begin{bmatrix} \Sigma y \\ \Sigma xy \end{bmatrix}, \quad \Sigma i = n \text{ (or } m \text{)}$$

$$b = \frac{\Sigma x \cdot \Delta y}{\sqrt{\Sigma \Delta x^2 \cdot \Sigma \Delta y^2}} = \frac{32.46 \times 10^4}{\sqrt{37.81 \times 10^4}} = 0.86$$

$$a = \bar{y} - b\bar{x} = 535 - 0.86 \times 1300 = -581$$

See Example 13.4.

Correlation coefficient

$$r = \frac{\Sigma \Delta x \cdot \Delta y}{\sqrt{\Sigma \Delta x^2 \cdot \Sigma \Delta y^2}} = \frac{32.46 \times 10^4}{\sqrt{37.81 \times 40.09 \times 10^8}} = 0.835$$

$$\text{also, } b = r \left(\frac{\sigma_y}{\sigma_x} \right) = r \sqrt{\frac{\Sigma \Delta y^2}{\Sigma \Delta x^2}}$$

$$0.86 = r \sqrt{\frac{40.09 \times 10^4}{37.81 \times 10^4}} \quad r = 0.835$$

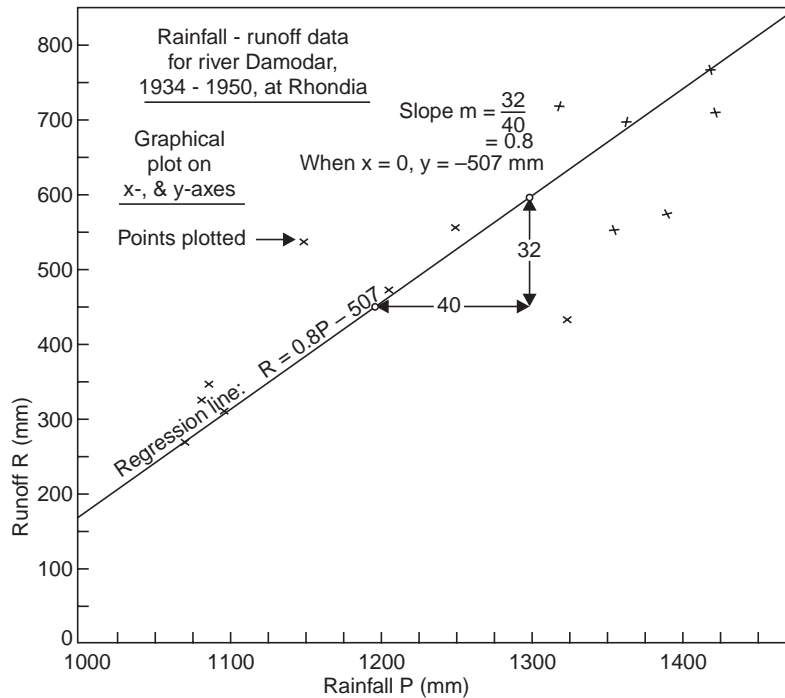

Fig. 13.1 Linear regression of Rainfall-Runoff (Example 13.1)

13.3 LINEAR MULTIPLE REGRESSION

A regression equation for estimating a dependent variable, say x_1 , from independent variables x_2, x_3, \dots is called a regression equation of x_1 on x_2, x_3, \dots and like that; for three variables, it is given by

$$x_1 = a + bx_2 + cx_3 \quad \dots(13.12)$$

The constants, a, b and c can be determined by the method of least squares. The least square regression plane of x_1 on x_2 and x_3 can be determined by solving simultaneously the three normal equations

$$\begin{aligned} \Sigma x_1 &= an + b \Sigma x_2 + c \Sigma x_3 \\ \Sigma x_1 x_2 &= a \Sigma x_2 + b \Sigma x_2^2 + c \Sigma x_2 x_3 \\ \Sigma x_1 x_3 &= a \Sigma x_3 + b \Sigma x_2 x_3 + c \Sigma x_3^2 \end{aligned} \quad \dots(13.13)$$

where n is the set of data points (x_1, x_2, x_3)

The standard error of estimate of x_1 , with respect to x_2 and x_3 is given by

$$S_{1.23} = \sqrt{\frac{\Sigma(x_1 - x_{1est})^2}{n - 3}} \quad \dots(13.14)$$

where x_{1est} = value of x_1 for the given value of x_2 and x_3 in Eq. (13.12).

The coefficient of multiple correlation is given by

$$r_{1.23} = \sqrt{\frac{1 - S_{1.23}^2}{\sigma_1^2}} \quad \dots(13.15)$$

where σ_1 = standard deviation of x_1 and $r_{1.23}^2$ is called the coefficient of multiple determination. The value of $r_{1.23}$ lies between 0 and 1. Also

$$r_{1.23} = \sqrt{\frac{r_{12}^2 + r_{13}^2 + 2r_{12}r_{13}r_{23}}{1 - r_{23}^2}} \quad \dots(13.16)$$

$$r_{1.23} = \sqrt{1 - (1 - r_{12}^2)(1 - r_{13}^2)} \quad \dots(13.17)$$

where

$$r_{12} = \frac{\sum x_1 x_2 - n\bar{x}_1 \bar{x}_2}{(n-1)\sigma_1 \sigma_2} \quad \dots(13.18)$$

r_{12} = the linear correlation coefficient between the variables x_1 and x_2 , ignoring the variable x_3 ; and similarly r_{13} and r_{23} . r_{12} , r_{13} , r_{23} are partial correlation coefficients.

From Eq. (13.15)

$$S_{1.23} = \sigma_1 \sqrt{1 - r_{1.23}^2} \quad \dots(13.19)$$

very similar to Eq. (13.9).

Example 13.2 The following are the data of the monthly Ground Water Table (GWT) fluctuations, precipitation and ground water pumping in the Cauvery delta in Thanjavur, TN. Obtain the regression line connecting GWT fluctuations with the precipitation and pumping.

| Month | GWT below MP (m) | Precipitation (mm) | G.W. pumping rate (Mm ³) |
|-------|------------------|--------------------|--------------------------------------|
| Jan. | 3.60 | 30 | 14.0 |
| Feb. | 4.05 | 52 | 23.4 |
| March | 4.12 | 95 | 32.4 |
| April | 4.57 | 90 | 51.2 |
| May | 4.80 | 200 | 62.3 |
| June | 4.95 | 280 | 79.5 |
| July | 5.02 | 168 | 61.4 |
| Aug. | 4.80 | 51 | 47.4 |
| Sept. | 4.42 | 18 | 34.4 |
| Oct. | 4.20 | 27 | 18.9 |
| Nov. | 3.90 | 52 | 1.8 |
| Dec. | 3.30 | 57 | 5.2 |

Solution The regression line computations are made in Table 13.2 and the normal equations are given below:

$$12a + 1120b + 432c = 51.73$$

$$1120a + 17.15 \times 10^4 b + 5.83 \times 10^4 c = 5138.8$$

$$432a + 5.83 \times 10^4 b + 1.68 \times 10^4 c = 1997.1$$

Simultaneous solution of the three equations gives

$$a = 4.02, b = 0.00865, c = -0.0144$$

Table 13.2 Multiple regression of GWT fluctuations w.r.t. precipitation and pumping. (Example 13.2)

| Month | $x_1(m)$ | x_2 Precipitation (mm) | x_3 Pumping (Mm^3) | x_1^2 | x_2^2 | x_3^2 | x_1x_2 | x_1x_3 | x_2x_3 | $x_1 - \bar{x}_1$ | $(x_1 - \bar{x}_1)^2$ | $x_2 - \bar{x}_2$ | $(x_2 - \bar{x}_2)^2$ | $x_3 - \bar{x}_3$ | $(x_3 - \bar{x}_3)^2$ |
|-----------------|----------|--------------------------------|--------------------------------|---------------|---------------|---------------|---------------|---------------|---------------|-------------------|-----------------------|-------------------|-----------------------|-------------------|-----------------------|
| Jan. | 3.60 | 30 | 14.0 | 900 | 196 | 108 | 50.4 | 420 | 420 | -0.71 | 0.504 | -63.33 | 4000 | -22 | 484 |
| Feb. | 4.05 | 52 | 23.4 | 2700 | 550 | 210 | 94.7 | 1217 | 1217 | -0.26 | 0.068 | -41.33 | 1710 | -12.6 | 160 |
| Mar. | 4.12 | 95 | 32.4 | 9030 | 1050 | 391 | 133.3 | 3080 | 3080 | -0.13 | 0.017 | 1.67 | 3 | -3.6 | 13 |
| April | 4.57 | 90 | 51.2 | 8100 | 2620 | 412 | 234 | 4610 | 4610 | 0.26 | 0.068 | -3.33 | 11 | 15.2 | 230 |
| May | 4.80 | 200 | 62.3 | 40000 | 3890 | 960 | 299 | 12460 | 12460 | 0.49 | 0.240 | 106.67 | 11370 | 26.3 | 700 |
| June | 4.95 | 280 | 79.5 | 78500 | 6320 | 1387 | 394 | 22240 | 22240 | 0.64 | 0.410 | 186.67 | 34800 | 43.5 | 1890 |
| July | 5.02 | 168 | 61.4 | 28300 | 377 | 843 | 308 | 10300 | 10300 | 0.71 | 0.504 | 74.67 | 5490 | 25.4 | 640 |
| Aug. | 4.80 | 51 | 47.4 | 2610 | 225 | 244 | 228 | 2420 | 2420 | 0.49 | 0.240 | 42.33 | 1797 | 11.4 | 130 |
| Sept. | 4.42 | 18 | 34.4 | 325 | 1182 | 79.5 | 152 | 620 | 620 | 0.11 | 0.012 | -75.33 | 5670 | -1.6 | 3 |
| Oct. | 4.20 | 27 | 18.9 | 730 | 358 | 113.3 | 79.5 | 510 | 510 | -0.11 | 0.012 | -66.33 | 4400 | 17.1 | 294 |
| Nov. | 3.90 | 52 | 1.8 | 271 | 3.3 | 203 | 7 | 93.5 | 93.5 | -0.41 | 0.168 | -41.33 | 1710 | -34.2 | 1180 |
| Dec. | 3.30 | 57 | 5.2 | 325 | 27.1 | 188 | 17.2 | 296 | 296 | -1.01 | 1.020 | -36.33 | 1320 | -30.8 | 950 |
| $\Sigma n = 12$ | 51.73 | 1120 | 431.9 | 17.15 | 1.68 | 5138.8 | 1997.1 | 5.83 | 5.83 | 3.263 | 72281 | 6674 | | | |
| | | | | $\times 10^4$ | $\times 10^4$ | $\times 10^4$ | $\times 10^4$ | $\times 10^4$ | $\times 10^4$ | | | | | | |

$$\bar{x} = \frac{\Sigma x}{n}, \bar{x}_1 = 4.31, \bar{x}_2 = 93.33, \bar{x}_3 = 36, \sigma = \sqrt{\frac{\Sigma(x - \bar{x})^2}{n - 1}}, \sigma_1 = 0.545, \sigma_2 = 81, \sigma_3 = 24.6$$

and the regression line is given by

$$x_1 = 4.02 + 0.00865x_2 + 0.0144x_3$$

or calling GWT as y (m), precipitation as P (mm) and pumping rate Q (Mm^3), the linear multiple **regression line** is given by

$$\mathbf{y = 4.02 + 0.00865 P + 0.0144 Q}$$

from which the GWT corresponding to a known precipitation and pumping rate can be computed.

To compute the multiple correlation coefficient $r_{1.23}$

$$r_{12} = \frac{\sum x_1x_2 - n\bar{x}_1\bar{x}_2}{(n-1)\sigma_1\sigma_2} = \frac{5138.8 - 12(4.31)(93.33)}{(12-1)(0.545)81} = 0.66$$

$$r_{13} = \frac{\sum x_1x_3 - n\bar{x}_1\bar{x}_3}{(n-1)\sigma_1\sigma_3} = \frac{1997.1 - 12(4.31)36}{(12-1)(0.545)24.6} = 0.92$$

$$r_{23} = \frac{\sum x_2x_3 - n\bar{x}_2\bar{x}_3}{(n-1)\sigma_2\sigma_3} = \frac{5.83 \times 10^4 - 12(93.33)36}{(12-1)81(24.6)} = 0.82$$

$$r_{1.23} = \sqrt{\frac{0.66^2 + 0.92^2 - 2(0.66)(0.92)(0.82)}{1 - (0.82)^2}} = 0.94$$

$$r_{1.23} = 0.94 \text{ indicates a close linear correlation}$$

Also from Eq. (13.17)

$$r_{1.23} = \sqrt{1 - (1 - 0.66^2)(1 - 0.92^2)} = 0.95$$

The standard error of estimate

$$S_{1.23} = \sigma_1 \sqrt{1 - r_{1.23}^2} = 0.545 \sqrt{1 - (0.94)^2}$$

$$\therefore S_{1.23} = 0.2$$

13.4 COAXIAL GRAPHICAL CORRELATION OF RAINFALL RUNOFF

Kohler and Linsley (1951) showed that the rate at which the soil moisture is depleted from a catchment is roughly proportional to the amount of storage and the soil moisture decreases logarithmically with time during periods (days) of no precipitation and

$$I_t = I_0 K^t \quad \dots(13.20)$$

where I_0 = initial value of the antecedent precipitation index (API, rainfall depth)

I_t = reduced value of API t -days later

K = recession factor ranging normally between 0.85 and 0.98

putting $t = 1$ day in Eq. (13.20), gives

$$I_t = I_0 K$$

i.e., the index for any day is equal to that of the previous day multiplied by the factor K . If rain occurs on any day, the amount of rain (rather precipitation minus runoff) is added to the index. Since K is a function of potential evapotranspiration, it should be related to seasons or calendar months. API is a satisfactory concept in estimating of runoff but systematic records of soil moisture are difficult to obtain for large areas.

Example 13.3 The API for a station was 50 mm on 1st July 1995; 40 mm rain fell on 6th July, 25 mm on 8th July and 30 mm on 9th July. Assuming a recession constant of 0.9, compute the API

(i) on 15th July.

(ii) on 15th July, assuming no rainfall during 1-15 July.

Solution (i) $I_t = I_0 K^t$, $I_0 = 50$ mm, $K = 0.9$

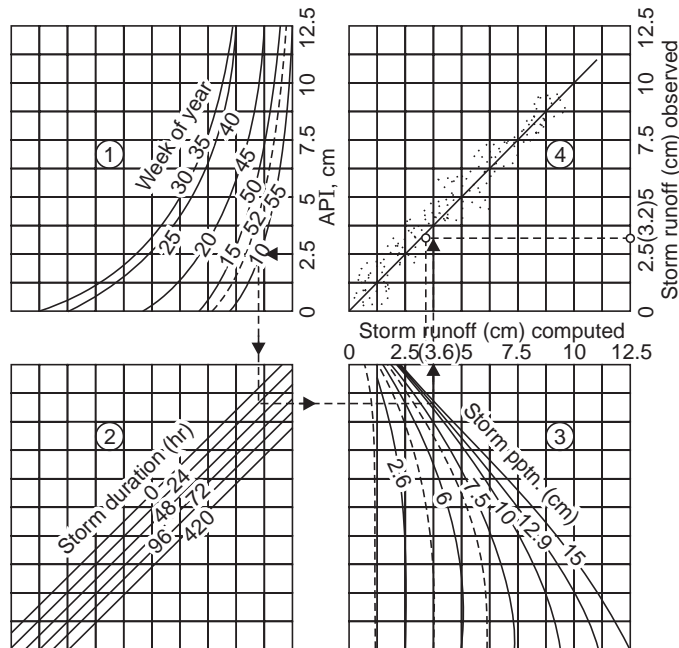

Fig. 13.2 Coaxial correlation for Monocacy river, USA (US National Weather Service)

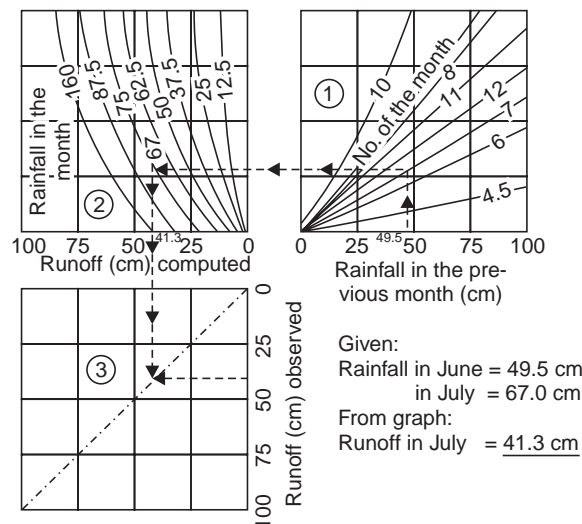

Fig. 13.3 Coaxial correlation for Kallada basin (after NN Pillai, 1964)

$$\begin{aligned}
 \text{on 6-July,} & \quad I_{6-1} = 50 \times 0.9^5 + 40 = 69.52 \text{ mm} \\
 \text{on 8-July,} & \quad I_{8-6} = 69.52 \times 0.9^2 + 25 = 81.31 \text{ mm} \\
 \text{on 9-July,} & \quad I_{9-8} = 81.31 \times 0.9 + 30 = 103.18 \text{ mm} \\
 \text{on 15-July,} & \quad I_{15-9} = 103.18 \times 0.9^6 = \mathbf{54.84 \text{ mm} = \text{API}}
 \end{aligned}$$

$$(ii) I_{15-1} = 50 \times 0.9^{14} = \mathbf{11.44 \text{ mm} = \text{API}}$$

Depending upon the API, the time of the year, duration and magnitude of the storm and the altitude, the estimation of runoff can be made by following the data as indicated by the dotted line on the graphical plot for the Monacacy river, USA (Fig. 13.2). Thus, a catchment with an API of 2.5 cm, in the 10th week of the year with the occurrence of storm of 24 hr duration and 12 cm depth of precipitation, will yield a runoff of 3.6 cm. This graphical approach is called *coaxial correlation* and is preferred to the multivariate linear correlation since many complex characteristics of the basin and storm are involved.

Another coaxial graphical correlation for estimating the monthly runoff from a catchment of the river Kallada in south Kerala (south India) as given by Pillai N.N. (1964) is shown in Fig. 13.3. Here the API has been taken as the precipitation of the previous month and the runoff for a particular month can be read on the graphical plot if the precipitation in the previous month is known. Thus, if the surface runoff in the month of July (7th month) is required, given the rainfalls for the months of June and July as 49.5 cm and 67.0 cm, respectively, then the runoff during the month of July is 41.3 cm, as indicated by the dotted line. If however, the total yield from the catchment is to be found out, the base flow (estimated as 30 cm) is to be added to the cumulative surface runoff of the whole year.

Though the correlation graph was developed for river Kallada (basin area = 874 km²) during 1952-57, it was also applied to compute the yield of river Pamba (basin area = 1700 km²) in 1953 and of river Achenkoil (basin area = 847 km²) in 1955 and was found to be within $\pm 4\%$ of the observed yield.

Example 13.4 Rainfall (P) and Runoff (R) data for a small catchment are given below:

| | | | | | | |
|-----------|----|----|----|---|----|----|
| P (mm): | 22 | 26 | 14 | 4 | 30 | 12 |
| R (mm): | 6 | 12 | 4 | 0 | 18 | 6 |

Develop a linear regression equation and find the coefficient of correlation; write a computer program in C-language.

Solution $R = aP + b$ $x = P$, $y = R$, $m = \text{no. of data pairs} = 6$

$$a = \frac{m \cdot \Sigma xy - \Sigma x \cdot \Sigma y}{m \cdot \Sigma x^2 - (\Sigma x)^2} \quad \dots(i), \quad b = (\Sigma y - a \Sigma x)/m \quad \dots(ii)$$

$$\text{Correlation coefficient, } r = \frac{m \Sigma xy - \Sigma x \cdot \Sigma y}{\sqrt{[m \Sigma x^2 - (\Sigma x)^2] [m \Sigma y^2 - (\Sigma y)^2]}} \quad \dots(iii)$$

$$\Sigma x = 108, \quad \Sigma y = 46, \quad (\Sigma x)^2 = 11664, \quad (\Sigma y)^2 = 1116$$

$$\Sigma x^2 = 484 + 676 + 196 + 16 + 900 + 144 = 2416$$

$$\Sigma y^2 = 36 + 144 + 16 + 0 + 324 + 36 = 556$$

$$\Sigma xy = 132 + 312 + 56 + 0 + 540 + 72 = 1112$$

Substituting these values in (i), (ii) and (iii),

$$a = 0.6, \quad b = -3.16, \quad r = 0.917 \rightarrow 1, \quad \therefore \text{Good fit}$$

Regression equation: $\mathbf{R = 0.6P = 3.16}$.

C-LANGUAGE CODE to fit a linear regression equation, Example 13.4, Chapter-13

```

/* program for a linear fit eqn.  $R = aP + b$  */
#include <stdio.h>
#include <math.h>
#include <conio.h>
main ( )
{
    Float sumx = 0, sumy = 0, sumxx = 0, sumyy = 0, sumxy = 0;
    float x[10], y[10], num, den, dx, dy, a, b, r;
    int i, m;
    printf ("Program LINREG/n");
    scanf ("%d", &m);/* m = No. of data pairs read */
    for (i = 1; i <= m; i ++ )
    {
        scanf ("%f%f", &x[i], &y[i]);
        sumx += x[i];
        sumy += y[i];
        sumxx += x[i]* x[i];
        sumyy += y[i]* y[i];
        sumxy += x[i]* y[i];
    }
    /* compute the parameters */
    num = m * sumxy – sumx * sumy;
    den = m * sumxx – sumx * sumx;
    a = num/den;
    b = (sumy – a * sumx)/m;
    dx = m * sumxx – sumx * sumx;
    dy = m * sumyy – sumy * sumy;
    r = num/sqrt (dx * dy);
    /* Output */
    printf ("\n No. of data pairs (x, y) m = % d\n", m);
    for (i = 1; i <= m; i ++ )
        printf (" % 4.1 f ", x [i]);
    printf ("\n");
    for (i = 1; i <= m; i ++ )
        printf (" % 4.1 f ", y [i]);
    printf ("\n\n");
    printf (" slope a = % 4.2f, intercept b = % 4.2 f\n", a,b);
}

```

```
printf ("Correlation Coefficient r = % 4.3 f ", r);
printf ("\n Regression Eqn. is R = % 4.2 f * P + % 4.2 f\n", a, b);
/* End of main */
```

Example 3.1

INPUT:

| | |
|----|----|
| 6 | |
| 22 | 6 |
| 26 | 12 |
| 14 | 4 |
| 4 | 0 |
| 30 | 18 |
| 12 | 6 |

OUTPUT: Program LINREG

No. of data pairs (x, y)m = 6

| | | | | | |
|------|------|------|-----|------|------|
| 22.0 | 26.0 | 14.0 | 4.0 | 30.0 | 12.0 |
| 6.0 | 12.0 | 4.0 | 0.0 | 18.0 | 6.0 |

Slope $a = 0.60$, intercept $b = -3.16$,

Correlation coefficient $r = 0.917$

Regression Eqn. is $R = 0.60 * P \pm 3.16$.

PROBLEMS

- 13.1** On a small area the rainfall-runoff (P - R) observations are given below. Establish an equation relating them by linear regression. Find the coefficient of correlation. What is the runoff expected for a rainfall of 20 mm?

| | | | | | | |
|-----------|----|----|----|---|----|----|
| P (mm): | 22 | 26 | 14 | 4 | 30 | 12 |
| R (mm): | 6 | 12 | 4 | 0 | 18 | 6 |

[Ans. $R = 0.6 P - 3.13$, $r = 0.92$; 8.87 mm]

- 13.2** The observed annual rainfall (P) and the corresponding runoff (R) for a small catchment are:

| | | | | | | |
|-----------|------|------|------|------|------|------|
| Year: | 1985 | 1986 | 1987 | 1988 | 1989 | 1990 |
| P (cm): | 90 | 110 | 40 | 130 | 146 | 100 |
| R (cm): | 30 | 50 | 6 | 62 | 75 | 40 |

Develop a rainfall-runoff regression equation and find the coefficient of correlation. What is the runoff expected for an annual rainfall of 80 cm? [Ans. $R = 0.657 P - 23.6$, $r = 0.95$; $R = 29$ cm]

- 13.3** The rainfall mass curve of a 3 hr storm gave the following results:

| | | | | | | | | | | | | | |
|-------------|-------|-------|-------|-------|-------|-------|-------|-------|-------|-------|-------|-------|-------|
| Time (hr): | 10.00 | 10.15 | 10.30 | 10.45 | 11.00 | 11.15 | 11.30 | 11.45 | 12.00 | 12.15 | 12.30 | 12.45 | 13.00 |
| Depth (mm): | 0 | 9.5 | 17.0 | 27.0 | 40.5 | 49.0 | 63.0 | 84.0 | 95.0 | 102 | 110 | 112 | 112 |

Develop a maximum intensity-duration relation of the form $i = \frac{a}{(t + b)^n}$ by linear regression.

$$\left[\text{Ans. } i = \frac{300}{(t + 12)^{0.4}} \right]$$

Hint: Find the max. intensities at 15-min intervals; use trial values of 'a'.

- 13.4** For the 'Stage-Discharge Data' of a stream in Example 6.2, develop a relation by linear regression of the form $Q = k(h - a)^n$.

Hint: Use trial values of a .

Chapter 14

STATISTICAL AND PROBABILITY ANALYSIS OF HYDROLOGICAL DATA

14.1 ELEMENTS OF STATISTICS

1. *Population and sample.* Observed values of x (variate) for a finite number of years is known as 'sample' of x . Say annual flood peaks or annual rainfall for 75 years gives the sample; on the other hand, population consists of the values of annual flood peaks from time immemorial to eternity. The 'population parameters' can be estimated by means of parameters obtained from the sample, known as 'sample parameters'. Each phenomena is characterised by a certain value, which varies in time and space. This characterisation is called 'variable' and its particular value is a 'variate'.

If the value of one variate is independent of any other, the variable in question is a 'random variable'. The hydrological processes are mostly random and hence the respective variables are equally random. All the time series (as well as other series) may be characterised by statistical parameters.

2. *Central tendency.* Three types of parameters are generally used to represent measures of central tendency.

(a) *Expected value.* This value of the random variable x is given by

$$\mu = \int_{-\infty}^{\infty} x f(x) dx \quad \dots(14.1)$$

This population parameter can be estimated by the sample parameters as

(i) Arithmetic mean $\bar{x} = \frac{\Sigma x}{n} \quad \dots(14.2)$

for grouped data $\bar{x} = \frac{\Sigma fx}{n} \quad \dots(14.2 a)$

(ii) Geometric mean $\bar{x}_g = (x_1 \cdot x_2 \cdot x_3 \cdot \dots \cdot x_n)^{1/n} \quad \dots(14.3)$

(iii) Harmonic mean $\bar{x}_h = \frac{n}{\Sigma \frac{1}{x}} \quad \dots(14.4)$

where n = the size of the sample, say the number of years of annual flood peaks.

For any set of variates $\bar{x} > \bar{x}_g > \bar{x}_h$

In most cases, the arithmetic mean gives the best estimate of the expected value, *i.e.*, $\mu \approx \bar{x}$.

(b) *Median*. The value of the variate such that half of the variates are below it and the other half above it, is called the *median* of the series, *i.e.*, it is the value of the variate having a 50% cumulative frequency.

(c) *Mode*. The value of the variate having the highest frequency is called the *mode*, Fig. 14.1 (see also Fig. 15.2). For unimodal curves, which are moderately skewed, the empirical relation is

$$\text{Mean} - \text{mode} = 3(\text{mean} - \text{median}) \quad \dots(14.5)$$

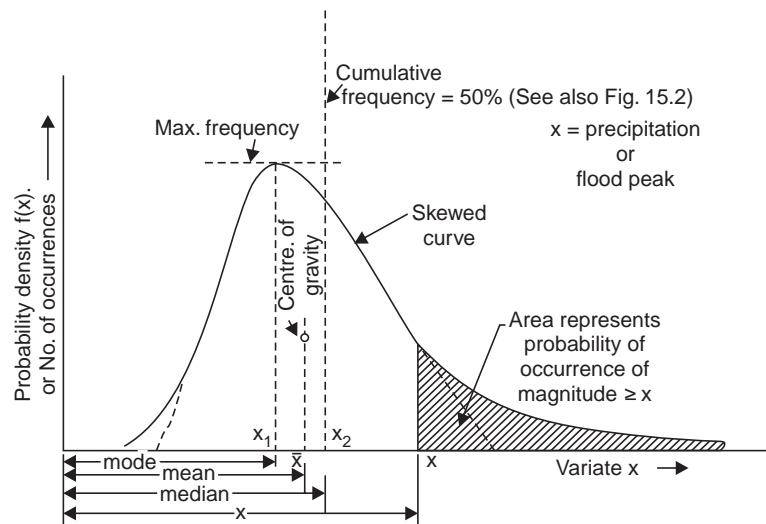

Fig. 14.1 Skewed distribution

3. *Variability*. The measures of variability or dispersion of a probability distribution curve are given by the following parameters.

(a) *Mean deviation*. The mean of the absolute deviations of values from their mean is called mean deviation (MD)

$$\text{MD} = \frac{\sum |x - \bar{x}|}{n} \quad \dots(14.6)$$

(b) *Standard deviation*. It is the square root of the mean-squared deviation of the variates from their mean, and the standard deviation for the population (σ_p) is given by

$$\sigma_p = \sqrt{\frac{\sum (x - \mu)^2}{n}} \quad \dots(14.7)$$

and this is estimated from the standard deviation for the sample (σ) given by

$$\sigma = \sqrt{\frac{\sum (x - \bar{x})^2}{n - 1}} \quad \dots(14.8)$$

$$= \sqrt{\frac{\sum x^2 - \bar{x} \sum x}{n - 1}} \quad \dots(14.8 a)$$

$$= \sqrt{\frac{\sum x^2 - \frac{(\sum x)^2}{n}}{n-1}} \quad \dots(14.8 b)$$

$$= \sqrt{\frac{n}{n-1} (\overline{x^2} - \bar{x}^2)} \quad \dots(14.8 c)$$

where

$$\overline{x^2} = \frac{\sum x^2}{n}$$

for grouped data,

$$\sigma = \sqrt{\frac{\sum f \cdot (x - \bar{x})^2}{n-1}} \quad \dots(14.8 d)$$

The dispersion about the mean is measured by the standard deviation, which is also called the root mean square of the departures from the mean, Fig. 14.2.

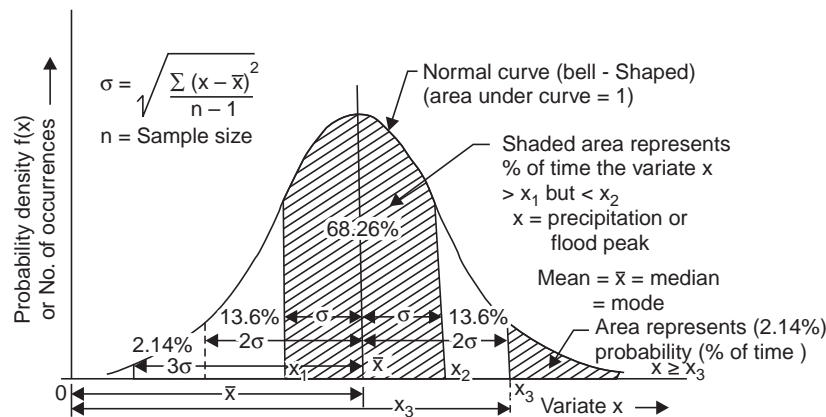

Fig. 14.2 Normal distribution curve

(c) *Variance.* The square of the standard deviation is called variance, i.e., given by σ_p^2 for the population and σ^2 for the sample.

(d) *Range.* The range (R) denotes the difference between the largest and smallest values of the sample and is given by Hurst (1951, 1956) and Klemes (1974) as

$$R = \sigma (n/2)^k, \quad 0.5 < k < 1 \quad \dots(14.9)$$

$$= 1.25 \sigma_p \sqrt{n} \quad \dots(14.9 a)$$

for a random normally distributed time series.

(e) *Coefficient of variation.* The standard deviation divided by the mean is called the coefficient of variation (C_v) and is given by

$$C_v = \frac{\sigma_p}{\mu} \approx \frac{\sigma}{\bar{x}} \quad \dots(14.10)$$

4. *Skewness (asymmetry).* The lack of symmetry of a distribution is called skewness or asymmetry. The population skewness (α) is given

$$\alpha = \frac{\sum (x - \mu)^3}{n} \quad \dots(14.11)$$

This is estimated from the sample skewness (a) given by

$$a = \frac{\Sigma (x - \bar{x})^3}{n - 1} \quad \dots(14.12)$$

For grouped data
$$a = \frac{\Sigma f(x - \bar{x})^3}{n - 1} \quad \dots(14.12 a)$$

The degree of the skewness of the distribution is usually measured by the 'coefficient of skewness' (C_s) and is given by

$$C_s = \frac{\alpha}{\sigma_p^3} \approx \frac{a}{\sigma^3} \quad \dots(14.13)$$

Another measure of skewness often used in practice is Pearson's skewness (S_k) given by

$$S_k = \frac{\mu - \text{mode}}{\sigma_p} \approx \frac{\bar{x} - \text{mode}}{\sigma} \quad \dots(14.14)$$

From Eq. (14.5),
$$S_k = \frac{3(\bar{x} - \text{median})}{\sigma} \quad \dots(14.15)$$

Example 14.1 For the grouped data of the annual floods in the river Ganga at Hardwar (1885-1971), find the mean, median, and mode. Determine the coefficients of skew and the coefficient of variation.

| Class interval (1000 cumec) | Frequency |
|--------------------------------|-----------|
| 0-2* | 0 |
| 2-4* | 17 |
| 4-6 | 27 |
| 6-8 | 18 |
| 8-10 | 18 |
| 10-12 | 3 |
| 12-14 | 0 |
| 14-16 | 2 |
| 16-18 | 1 |
| 18-20 | 1 |

*from 0 to <2.

from 2 to <4, and like that.

Solution The computations are made in Table 14.1

(i) Mean $\bar{x} = 6.6$ tcm

(ii) Standard deviation, $\sigma = 3.16$ tcm

(iii) Median = $L_{md} + \left(\frac{n/2 - CF}{f_{md}} \right) CI$

$$= 4 + \left(\frac{87/2 - 17}{27} \right) 2 = \mathbf{6 \text{ tcm}}$$

$$\begin{aligned}
 \text{(vi) Coefficient of variation, } C_v &= \frac{\sigma}{\bar{x}} \times 100 \\
 &= \frac{3.16}{6.6} \times 100 = 47.8\%
 \end{aligned}$$

Assignment problem

For the grouped data of the partial duration floods ($Q_b > 4333$ cumec) of river Ganga at Hardwar (1885-1971), find the mean, median and mode. Also determine the coefficient/s of skew and coefficient of variation.

| <i>Class interval (1000 cumec)</i> | <i>Frequency (or no. of occurrences)</i> |
|--|--|
| 4-6* | 86 |
| 6-8* | 56 |
| 8-10 | 22 |
| 10-12 | 6 |
| 12-14 | 1 |
| 14-16 | 2 |
| 16-18 | 1 |
| 18-20 | 1 |

*from 4 to <6.

from 6 to <8, and like that.

[Hint See Fig. 15.4]

14.2 PROBABILITY OF HYDROLOGIC EVENTS

Since most hydrologic events are represented by continuous random variables, their density functions denote the probability distribution of the magnitudes. Some of the frequently used density functions used in hydrologic analysis are given below.

(a) *Normal distribution.* The density function of normal probability distribution is given by

$$f(x) = \frac{1}{\sigma_p \sqrt{2\pi}} \exp\left(-\frac{(x-\mu)^2}{2\sigma_p^2}\right), \quad -\infty < x < \infty \quad \dots(14.17)$$

where σ_p and μ are the two parameters, which affect the distribution, Fig. 14.2.

In this distribution, the mean, mode and median are the same and the area under the curve is unity.

(b) *Gamma distribution.* The density function of this distribution is given by

$$\begin{aligned}
 f(x) &= \frac{x^a e^{-x/b}}{a! b^{a+1}}, & \text{for } 0 < x < \infty & \dots(14.18) \\
 &= 0, & \text{elsewhere} &
 \end{aligned}$$

where a and b are the two parameters, which affect the distribution (Fig. 14.3). A change of the parameter b merely changes the scale of the two axes.

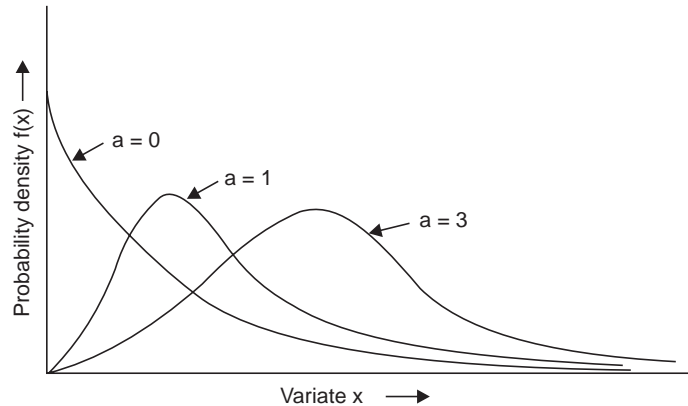

Fig. 14.3 Gamma distribution

Here $\mu = b(a + 1)$ and $\sigma_p^2 = b^2(a + 1)$

(c) *Poisson distribution*. If n is very large and y is very small, such that $y \cdot n = m$ is a positive number, then the probability density function which is in the Poisson distribution is given by

$$y = f(x) = \frac{m^x \cdot e^{-m}}{x!}$$

Under abnormal skewness, the Poisson distribution is useful. The statistical parameters are $\sigma_p = \mu$ and skewness = $\frac{1}{\sqrt{\mu}}$.

(d) *Lognormal distribution*. A random variable x (variate) is said to be in log-normal distribution if the logarithmic values of x is distributed normally. The density function in this distribution is given by

$$f(x) = \frac{1}{\sigma_y \sqrt{2\pi}} \exp\left(-\frac{(y - \mu_y)^2}{2\sigma_y^2}\right) \quad \dots(14.20)$$

where $y = \ln x$, $x =$ variate, $\mu_y =$ mean of y , $\sigma_y =$ standard deviation of y . This is a skew distribution of unlimited range in both directions. Chow has derived the statistical parameters for x as

$$\mu = \exp(\mu_y + \sigma_y^2/2), \quad \sigma = \mu \sqrt{\exp \sigma_y^2 - 1} \quad \dots(14.21)$$

$$C_v = \sqrt{\exp \sigma_y^2 - 1}, \quad C_s = 3C_v + C_v^3$$

(e) *Extremal distribution* This is the distribution of the n extreme values (largest or the smallest), each value being selected out of p values contained in each of n samples, which approaches an asymptotic limit as p is increased indefinitely. Depending on the initial distribution of the $n.p$ values, three asymptotic (types) extremal distributions can be derived.

(i) *Type-I distribution* In this distribution, the density function is given by

$$f(x) = \frac{1}{c} \exp \left[\left(-\frac{a+x}{c} \right) - \exp \left(-\frac{a+x}{c} \right) \right], \quad -\infty < x < \infty \quad \dots(14.22)$$

where x is the variate and a, c are the parameters. By the method of moments the parameters have been evaluated as

$$a = \gamma c - \mu, \quad c = \frac{\sqrt{6}}{\pi} \sigma \quad \dots(14.23)$$

where $\gamma = 0.57721 \dots$ Euler's constant. The distribution has a constant $C_s = 1.139$. The **Gumbel distribution** used in flood frequency analysis is an example of this type.

(ii) *Type-II distribution* In this type, the cumulative probability is given

$$F(x) = \exp [-(\theta/x)^k], \quad -\infty < x < \infty \quad \dots(14.24)$$

where θ and k are the parameters.

(iii) *Type-III distribution*. In this type, the cumulative probability is given by

$$F(x) = \exp \left[-\left(\frac{x-\epsilon}{\theta-\epsilon} \right)^k \right], \quad -\infty < x \leq \epsilon \quad \dots(14.25)$$

where θ and k are the parameters. **Weibull distribution used in draught-frequency analysis** is an example of this type.

(f) *Pearson's Type-III distribution* This is a skew distribution with limited range in the left direction, usually bell shaped. The Pearson curve (Fig. 14.4), is truncated on one side of the axis of the variate, i.e., below a certain value of the variate the probability is zero, but it is infinite converging asymptotically to the axis of the variate. This means even values infinitely large (or small) have a certain probability of occurrence.

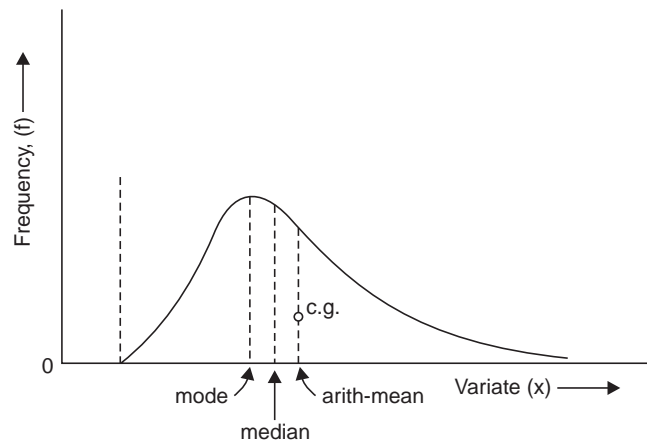

Fig. 14.4 Pearson's Type-III distribution

(g) *Logarithmic Pearson Type-III distribution.* This distribution has the advantage of providing a skew adjustment. If the skew is zero, the Log-Pearson distribution is identical to the log-normal distribution.

The probability density function for type III (with origin at the mode) is

$$f(x) = f_0 \left(1 - \frac{x}{a}\right)^c \exp(-cx/2) \quad \dots(14.26)$$

where
$$c = \frac{4}{\beta} - 1, \quad a = \frac{c}{2} \frac{\mu_3}{\mu_2}, \quad \beta = \frac{\mu_3^2}{\mu_2^2} \quad \dots(14.26 a)$$

$$f_0 = \frac{n}{a} \frac{e^{c+1}}{e^c \Gamma(c+1)} \quad \dots(14.26 b)$$

- μ_2 = the variance,
- μ_3 = third moment about the mean = $\sigma^6 g$
- e = the base of the napierian logarithms
- Γ = the gamma function
- n = the number of years of record
- g = the skew coefficient
- σ = the standard deviation

The US Water Resources Council (1967) adopted the Log-Pearson Type-III distribution (to achieve standardisation of procedures) for use by federal agencies. The procedure is to convert the data series to logarithms and compute.

Mean:
$$\overline{\log x} = \frac{\Sigma \log x}{n} \quad \dots(14.27)$$

Standard deviation:
$$\sigma_{\log x} = \sqrt{\frac{\Sigma (\log x - \overline{\log x})^2}{n - 1}} \quad \dots(14.27 a)$$

Skew coefficient:
$$g = \frac{n \Sigma (\log x - \overline{\log x})^3}{(n - 1)(n - 2)(\sigma_{\log x})^3} \quad \dots(14.27 b)$$

The values of x for various recurrence intervals are computed from

$$\log x = \overline{\log x} + K \sigma_{\log x} \quad \dots(14.28)$$

and the frequency factor K is obtained from Table 14.2 for the computed value of 'g' and the desired recurrence interval (see Example 15.1).

Table 14.2. K-Values for the Log-Pearson Type-III Distribution

| <i>Skew coefficient (g)</i> | <i>Recurrence interval (T-yr)</i> | | | | | | |
|-------------------------------------|--|-----------|-----------|-----------|-----------|------------|------------|
| | <i>2</i> | <i>5</i> | <i>10</i> | <i>25</i> | <i>50</i> | <i>100</i> | <i>200</i> |
| | <i>Per cent chance (annual probability of occurrence P(%))</i> | | | | | | |
| | <i>50</i> | <i>20</i> | <i>10</i> | <i>4</i> | <i>2</i> | <i>1</i> | <i>0.5</i> |
| 3.5 | -0.396 | 0.420 | 1.180 | 2.278 | 3.152 | 4.051 | 4.970 |
| 2.5 | -0.360 | 0.518 | 1.250 | 2.162 | 3.048 | 3.845 | 4.652 |
| 2.0 | -0.307 | 0.609 | 1.302 | 2.219 | 2.912 | 3.605 | 4.298 |
| 1.8 | -0.282 | 0.643 | 1.318 | 2.193 | 2.848 | 3.499 | 4.147 |
| 1.6 | -0.254 | 0.675 | 1.329 | 2.163 | 2.780 | 3.388 | 3.990 |
| 1.4 | -0.225 | 0.705 | 1.337 | 2.128 | 2.706 | 3.271 | 3.828 |
| 1.2 | -0.195 | 0.732 | 1.340 | 2.087 | 2.626 | 3.149 | 3.661 |
| 1.0 | -0.164 | 0.758 | 1.340 | 2.043 | 2.542 | 3.022 | 3.489 |
| 0.9 | -0.148 | 0.769 | 1.339 | 2.018 | 2.498 | 2.957 | 3.401 |
| 0.8 | -0.132 | 0.780 | 1.336 | 1.993 | 2.453 | 2.891 | 3.312 |
| 0.7 | -0.116 | 0.790 | 1.333 | 1.967 | 2.407 | 2.824 | 3.223 |
| 0.6 | -0.099 | 0.800 | 1.328 | 1.939 | 2.359 | 2.755 | 3.132 |
| 0.5 | -0.083 | 0.808 | 1.323 | 1.910 | 2.311 | 2.686 | 3.041 |
| 0.4 | -0.066 | 0.816 | 1.317 | 1.880 | 2.261 | 2.615 | 2.949 |
| 0.3 | -0.050 | 0.823 | 1.309 | 1.849 | 2.211 | 2.544 | 2.856 |
| 0.2 | -0.033 | 0.830 | 1.301 | 1.818 | 2.159 | 2.472 | 2.763 |
| 0.1 | -0.017 | 0.836 | 1.292 | 1.785 | 2.107 | 2.400 | 2.670 |
| 0 | 0.000 | 0.841 | 1.282 | 1.751 | 2.054 | 2.326 | 2.576 |
| -0.1 | 0.017 | 0.846 | 1.270 | 1.716 | 2.000 | 2.252 | 2.482 |
| -0.2 | 0.033 | 0.850 | 1.258 | 1.680 | 1.945 | 2.178 | 2.388 |
| -0.3 | 0.050 | 0.853 | 1.245 | 1.643 | 1.890 | 2.104 | 2.294 |
| -0.4 | 0.066 | 0.855 | 1.231 | 1.606 | 1.834 | 2.029 | 2.201 |
| -0.5 | 0.083 | 0.860 | 1.216 | 1.567 | 1.777 | 1.955 | 2.108 |
| -0.6 | 0.099 | 0.857 | 1.200 | 1.528 | 1.720 | 1.880 | 2.016 |
| -0.7 | 0.115 | 0.857 | 1.183 | 1.488 | 1.663 | 1.806 | 1.926 |
| -0.8 | 0.132 | 0.856 | 1.166 | 1.448 | 1.606 | 1.733 | 1.837 |
| -0.9 | 0.148 | 0.854 | 1.147 | 1.407 | 1.549 | 1.660 | 1.749 |
| -1.0 | 0.164 | 0.852 | 1.128 | 1.366 | 1.492 | 1.588 | 1.664 |
| -1.2 | 0.195 | 0.843 | 1.086 | 1.282 | 1.379 | 1.449 | 1.501 |
| -1.4 | 0.225 | 0.832 | 1.041 | 1.198 | 1.270 | 1.318 | 1.351 |
| -1.6 | 0.254 | 0.817 | 0.994 | 1.116 | 1.166 | 1.197 | 1.216 |
| -1.8 | 0.282 | 0.799 | 0.945 | 1.035 | 1.069 | 1.087 | 1.097 |
| -2.0 | 0.307 | 0.777 | 0.895 | 0.959 | 0.980 | 0.990 | 0.995 |
| -2.5 | 0.360 | 0.710 | 0.771 | 0.793 | 0.798 | 0.799 | 0.800 |
| -3.0 | 0.396 | 0.636 | 0.660 | 0.666 | 0.666 | 0.667 | 0.667 |

Chapter 15

FLOOD FREQUENCY—PROBABILITY AND STOCHASTIC METHODS

15.1 FLOOD FREQUENCY METHODS

For the annual flood data of Lower Tapti River at Ukai (30 years: 1939–1968) in Example 8.5 the flood frequencies of 2-, 10-, 50-, 100-, 200-, and 1000-year floods have been worked out below by the probability methods developed by Fuller, Gumbel, Powell, Ven Te Chow, and stochastic methods, and the flood frequency curves are drawn on a semi-log paper as shown in Fig. 15.1. It can be seen that the Gumbel's method gives the prediction of floods of a particular frequency exceeding the observed floods by a safe margin and can be adopted in the design of the structure.

1. Fuller's formula. $Q_T = \bar{Q} (1 + 0.8 \log T)$... (15.1)

From Table 8.5, $\bar{Q} = 14.21$ thousand cumec (tcm)

| T | $\log T$ | $0.8 \log T$ | $Q_T = \bar{Q} (1 + 0.8 \log T)$ (tcm) |
|------|----------|--------------|---|
| 1000 | 3.0 | 2.4 | 48.3 |
| 200 | 2.3010 | 1.8408 | 40.4 |
| 100 | 2.0 | 1.6 | 37.0 |
| 50 | 1.6990 | 1.3592 | 33.5 |
| 10 | 1.0 | 0.8 | 25.6 |
| 2 | 0.3010 | 0.2408 | 17.35 |

2. Gumbel's method. According to the extreme value distribution, the probability of occurrence of a flood peak $\geq Q$, is given by

$$P = 1 - e^{-e^{-y}} \quad \dots(15.2)$$

the reduced variate y is given by

$$y = -0.834 - 2.303 \log \log \frac{T}{T-1}$$

or, $y = -0.834 - 2.303 X_T$... (15.3)

where $X_T = \log \log \frac{T}{T-1}$... (15.3 a)

The reduced variate y is linear with the variate Q (annual flood peak) itself and is given by

$$y = \sigma_n \left(\frac{Q - \bar{Q}}{\sigma} \right) + \bar{y}_n \quad \dots(15.4)$$

where σ_n (reduced standard deviation) and \bar{y}_n [reduced mean (to mode)] are functions of the sample size n and are given in Table 15.1.

$$\therefore Q_T = \bar{Q} + \left(\frac{y - \bar{y}_n}{\sigma_n} \right) \sigma \quad \dots(15.5)$$

or
$$Q_T = \bar{Q} + K\sigma \quad \dots(15.6)$$

where the frequency factor $K = \frac{y - \bar{y}_n}{\sigma_n}$ and Q_T = annual flood peak, which has a recurrence interval T .

Since the coefficient of variation $C_v = \sigma/\bar{Q}$

$$Q_T = \bar{Q} (1 + KC_v) \quad \dots(15.7)$$

The frequency factor K for the sample size n and the desired recurrence interval T can be directly read from Table 15.2.

There are two approaches to the solution by the Gumbel's method. The first approach is, for a given annual flood peak (Q_T), to find its recurrence interval T and probability of occurrence P , for which the following sequence of tabulation should follow:

Table 15.1 Reduced mean (\bar{y}_n) and reduced standard deviation (σ_n) as functions of sample size n

| Size of sample n | \bar{y}_n | σ_n |
|--------------------|-------------|------------|
| 10 | 0.4952 | 0.2457 |
| 15 | 0.5128 | 1.0206 |
| 20 | 0.5236 | 0.0628 |
| 25 | 0.5309 | 1.6915 |
| 30 | 0.5362 | 1.1124 |
| 35 | 0.5403 | 1.1283 |
| 40 | 0.5436 | 1.1413 |
| 45 | 0.5436 | 1.1518 |
| 50 | 0.5465 | 1.1607 |
| 55 | 0.5504 | 1.1681 |
| 60 | 0.5521 | 1.1747 |
| 65 | 0.5536 | 1.1803 |
| 70 | 0.5548 | 1.1854 |
| 75 | 0.5549 | 1.1898 |

(Contd.)...

| | | |
|------|--------|--------|
| 80 | 0.5569 | 1.1938 |
| 85 | 0.5578 | 1.1973 |
| 90 | 0.5539 | 1.2007 |
| 95 | 0.5553 | 1.2038 |
| 100 | 0.5600 | 1.2065 |
| 200 | 0.5672 | 1.2359 |
| 500 | 0.5724 | 1.2588 |
| 1000 | 0.5745 | 1.2685 |

| Q_T | y from Eq. (15.4) | X_T from Eq. (15.3) | T from Eq. (15.3 a) | $P = \frac{1}{T} \times 100$ (%) |
|-------|------------------------|--------------------------|--------------------------|-------------------------------------|
|-------|------------------------|--------------------------|--------------------------|-------------------------------------|

The second approach is, for a given recurrence interval T , to find the annual flood peak Q_T (which will be equalled or exceeded), for which the following sequence of tabulation should follow; the computations are made for Lower Tapti river at Ukai.

| T (yr) | $X_T = \log \left(\log \frac{T}{T-1} \right)$ | $y = -0.834 - 2.3 X_T$ | $K^* = \frac{y - \bar{y}_n}{\sigma_n}$ | $Q_T^\dagger = \bar{Q} + K\sigma$ (tcm) | $P = \frac{1}{T} \times 100$ % |
|----------|--|------------------------|--|--|-----------------------------------|
| 1000 | -3.361 | 6.907 | 5.67 | 69.21 | 0.1 |
| 200 | -2.662 | 5.295 | 4.23 | 55.51 | 0.5 |
| 100 | -2.360 | 4.600 | 3.61 | 49.21 | 1.0 |
| 50 | -2.056 | 3.901 | 3.02 | 43.51 | 2.0 |
| 10 | -1.339 | 2.250 | 1.52 | 28.96 | 10 |
| 2 | -0.521 | 0.366 | -0.14 | 12.85 | 50 |

*(i) for the sample size $n = 30$, $\bar{y}_n = 0.5362$, $\sigma_n = 1.1124$.

(ii) for the desired T and the number of years of record n , the value of K can be directly read from Table 15.2.

$\dagger \bar{Q} = 14.21$ tcm, $\sigma = 9.7$ tcm

Gumbel's method can be viewed as a modification of the earlier probability methods given by Eqs. (8.11, a and b) as

$$T = \frac{n}{m + c - 1} \quad \dots(15.8)$$

where $c =$ Gumbel's correction, and depends upon the ratio m/n , as given below:

| | | | | | | | | | | | | |
|--------|---|------|------|-------|------|------|------|------|------|-----|------|------|
| $m/n:$ | 1 | 0.9 | 0.8 | 0.7 | 0.6 | 0.5 | 0.4 | 0.3 | 0.2 | 0.1 | 0.08 | 0.04 |
| $c:$ | 1 | 0.95 | 0.88 | 0.845 | 0.78 | 0.73 | 0.66 | 0.59 | 0.52 | 0.4 | 0.38 | 0.28 |

Table 15.2 Frequency factor (K) for Gumbel's method. (extremal value: Type-I distribution)

| Years of record (n) | Recurrence interval (T_{-yr}) | | | | | | | | | | | | | |
|----------------------------|-----------------------------------|-------|-------|-------|-------|-------|-------|-------|-------|-------|-------|------|------|-------|
| | 2 | 5 | 10 | 15 | 20 | 25 | 30 | 50 | 60 | 75 | 100 | 200 | 400 | 1000 |
| 15 | | 0.967 | 1.703 | 2.117 | 2.410 | 2.632 | 2.823 | 3.321 | 3.501 | 3.721 | 4.005 | | | 6.265 |
| 20 | -0.147 | 0.919 | 1.625 | 2.023 | 2.302 | 2.517 | 2.690 | 3.179 | 3.352 | 3.563 | 3.836 | 4.49 | 5.15 | 6.006 |
| 25 | | 0.888 | 1.575 | 1.963 | 2.235 | 2.444 | 2.614 | 3.088 | 3.257 | 3.463 | 3.729 | | | 5.848 |
| 30 | -1.152 | 0.866 | 1.541 | 1.922 | 2.188 | 2.393 | 2.560 | 3.026 | 3.191 | 3.393 | 3.653 | 4.28 | 4.91 | 5.727 |
| 35 | | 0.851 | 1.516 | 1.891 | 2.152 | 2.354 | 2.520 | 2.979 | 3.142 | 3.341 | 3.598 | | | |
| 40 | -0.155 | 0.838 | 1.495 | 1.866 | 2.126 | 2.326 | 2.489 | 2.943 | 3.104 | 3.301 | 3.554 | 4.16 | 4.78 | 5.576 |
| 45 | | 0.829 | 1.478 | 1.847 | 2.104 | 2.303 | 2.464 | 2.913 | 3.078 | 3.268 | 3.520 | | | |
| 50 | -0.156 | 0.820 | 1.466 | 1.831 | 2.086 | 2.283 | 2.443 | 2.889 | 3.048 | 3.241 | 3.491 | 4.08 | 4.56 | 5.478 |
| 55 | | 0.813 | 1.455 | 1.818 | 2.071 | 2.267 | 2.426 | 2.869 | 2.027 | 3.219 | 3.467 | | | |
| 60 | | 0.807 | 1.446 | 1.806 | 2.059 | 2.253 | 2.411 | 2.852 | 3.008 | 3.200 | 3.446 | | | |
| 65 | | 0.801 | 1.437 | 1.796 | 2.048 | 2.241 | 2.398 | 2.837 | 2.992 | 3.183 | 3.429 | | | |
| 70 | | 0.797 | 1.430 | 1.788 | 2.038 | 2.230 | 2.387 | 2.824 | 2.979 | 3.169 | 3.413 | | | 5.359 |
| 75 | | 0.792 | 1.423 | 1.780 | 2.029 | 2.220 | 2.377 | 2.812 | 2.967 | 3.155 | 3.400 | | | |
| 80 | | 0.788 | 1.417 | 1.773 | 2.020 | 2.212 | 2.368 | 2.802 | 2.956 | 3.145 | 3.387 | | | |
| 85 | | 0.785 | 1.413 | 1.767 | 2.013 | 2.205 | 2.361 | 2.793 | 2.946 | 3.135 | 3.376 | | | |
| 90 | | 0.782 | 1.409 | 1.762 | 2.007 | 2.198 | 2.353 | 2.785 | 2.938 | 3.125 | 3.367 | | | |
| 95 | | 0.780 | 1.405 | 1.757 | 2.002 | 2.193 | 2.347 | 2.777 | 2.930 | 3.116 | 3.357 | | | |
| 100 | -0.160 | 0.779 | 1.401 | 1.752 | 1.998 | 2.187 | 2.341 | 2.770 | 2.922 | 3.109 | 3.349 | 3.93 | 4.51 | 5.261 |

3. Powell method. A modification in the value of K in Eq. (15.6) was made by R.W. Powell (1943)

$$K = -\frac{\sqrt{6}}{\pi} \left[\gamma + \ln \ln \frac{T}{T-1} \right] \quad \dots(15.9)$$

where

$$\gamma = \text{Euler's constant} = 0.5772 \dots$$

$$\ln = \log_e$$

Simplifying, $K = -1.1 - 1.795 X_T \quad \dots(15.10)$

Then $Q_T = \bar{Q} + K\sigma \quad \dots(15.11)$

The computations are made for lower Tapi river at Ukai as per Powell method, below:

| T (yr) | $X_T = \log \left(\log \frac{T}{T-1} \right)$ | $K = -1.1$ $- 1.795 X_T$ | $K\sigma^*$ | $Q_T = \bar{Q} + K\sigma$ (tcm) | $P = \frac{1}{T} \times 100$ (%) |
|-------------|--|-----------------------------|-------------|------------------------------------|-------------------------------------|
| 1000 | -3.361 | 4.93 | 47.8 | 62.01 | 0.1 |
| 200 | -2.662 | 3.68 | 35.8 | 50.01 | 0.5 |
| 100 | -2.360 | 3.13 | 30.4 | 44.61 | 1.0 |
| 50 | -2.056 | 2.58 | 25.0 | 39.21 | 2.0 |
| 10 | -1.339 | 1.30 | 12.6 | 26.81 | 10 |
| 2 | -0.521 | -0.164 | -1.6 | 12.62 | 50 |

$$*\bar{Q} = 14.21 \text{ tcm}, \sigma = 9.7 \text{ tcm}$$

4. Ven Te Chow method. Another modification of the Gumbel's method was made by V.T. Chow by using the frequency factor. The equation is

$$Q_T = a + bX_T \quad \dots(15.12)$$

where

$$X_T = \log \left(\log \frac{T}{T-1} \right) \quad \dots(15.12 a)$$

a, b = parameters estimated by the method of moments from the observed data. The following equations are derived from the method of least squares.

$$\begin{aligned} \Sigma Q &= an + b \Sigma X_T \\ \Sigma (QX_T) &= a \Sigma X_T + b \Sigma (X_T^2) \end{aligned} \quad \dots(15.13)$$

from which a and b can be solved.

In this method, a plotting position has been assigned for each value of Q when arranged in the descending order or magnitude of flood peaks. For example, if an annual flood peak Q_T has a rank m , its plotting position

$$T = \frac{n + 1}{m} \quad \dots(15.14)$$

From Eq. (15.12 a),

$$X_T = \log \left(\log \frac{T}{T-1} \right)$$

putting the value of T from Eq. (15.14)

$$X_T = \log \left(\log \frac{n+1}{n+1-m} \right) \quad \dots(15.15)$$

The computation is made in Table 15.3 for Lower Tapi river at Ukai.

Table 15.3 Computation for determining a , b : Ven Te Chow method

| Order no. (m) | Flood peak Q (tcm) | $X_T = \log \left(\log \frac{n+1}{n+1-m} \right)$ | QX_T | X_T^2 |
|----------------------|-------------------------|--|----------|----------|
| 1 | 42.45 | -1.848 | -78.4 | 3.41 |
| 2 | 37.30 | -1.538 | -57.4 | 2.37 |
| 3 | 29.30 | -1.468 | -43.0 | 2.15 |
| 4 | 24.20 | -1.223 | -29.6 | 1.50 |
| 5 | 22.62 | -1.119 | -25.3 | 1.25 |
| 6 | 21.24 | -1.032 | -21.9 | 1.06 |
| 7 | 20.86 | -0.965 | -20.1 | 0.93 |
| 8 | 19.65 | -0.886 | -17.4 | 0.79 |
| 9 | 18.70 | -0.830 | -15.5 | 0.69 |
| 10 | 18.30 | -0.794 | -14.5 | 0.63 |
| 11 | 14.57 | -0.718 | -10.5 | 0.52 |
| 12 | 14.00 | -0.672 | -9.4 | 0.45 |
| 13 | 12.88 | -0.627 | -8.1 | 0.39 |
| 14 | 12.45 | -0.585 | -7.3 | 0.34 |
| 15 | 11.43 | -0.542 | -6.2 | 0.29 |
| 16 | 10.34 | -0.502 | -4.9 | 0.25 |
| 17 | 9.72 | -0.462 | -4.5 | 0.21 |
| 18 | 9.68 | -0.434 | -4.2 | 0.19 |
| 19 | 8.50 | -0.386 | -3.3 | 0.15 |
| 20 | 8.44 | -0.347 | -2.9 | 0.12 |
| 21 | 7.65 | -0.308 | -2.4 | 0.09 |
| 22 | 7.27 | -0.270 | -2.0 | 0.07 |
| 23 | 7.22 | -0.230 | -1.7 | 0.05 |
| 24 | 6.48 | -0.190 | -1.2 | 0.04 |
| 25 | 6.23 | -0.146 | -0.9 | 0.02 |
| 26 | 6.09 | -0.102 | -0.6 | 0.01 |
| 27 | 5.81 | -0.051 | -0.3 | 0.03 |
| 28 | 4.82 | 0.006 | 0.03 | 0.000036 |
| 29 | 4.39 | 0.077 | 0.34 | 0.0059 |
| 30 | 3.68 | 0.174 | 0.64 | 0.0303 |
| $\Sigma n = 30$ | 426.27 | - 16.00 | - 392.30 | 18.04 |

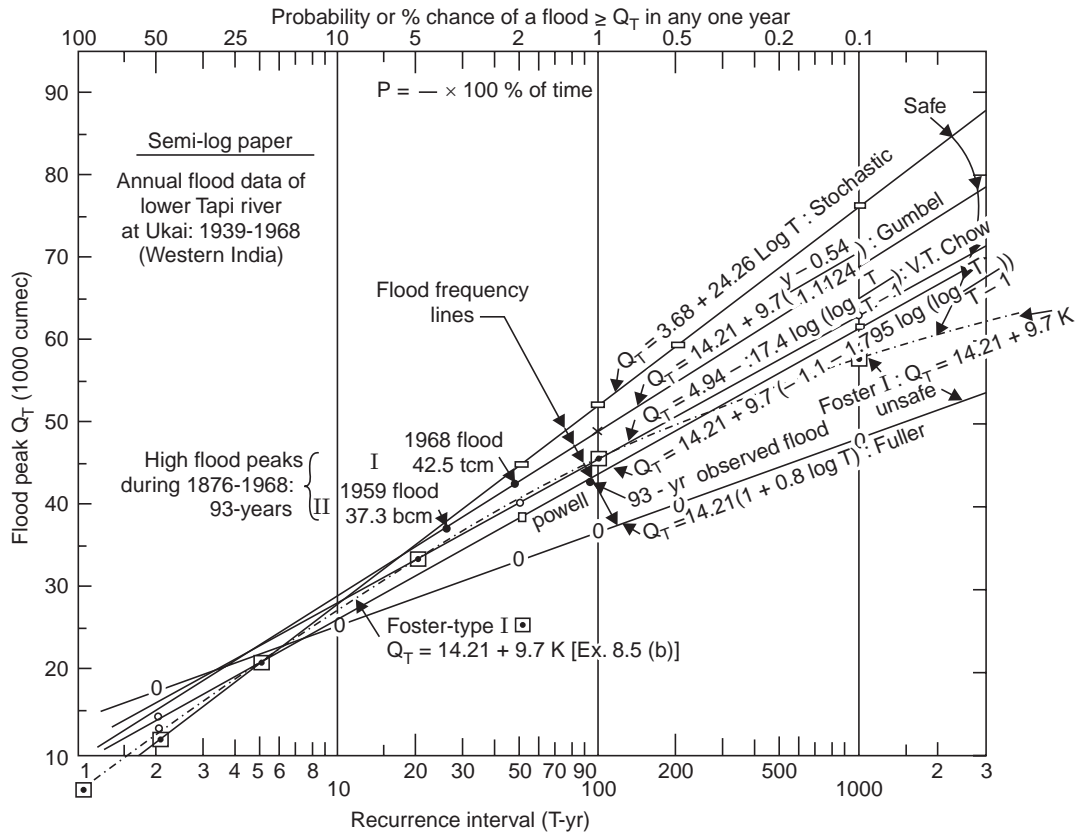

Fig. 15.1 Flood frequency curves of lower Tapi at Ukai (1939-1968)

Substituting the values in Eq. (15.13)

$$426.27 = 30a - 16b$$

$$-392.30 = -16a + 18.04b$$

Solving the equations

$$a = 4.94, b = -17.4$$

Then $Q_T = a + bX_T \quad \therefore \quad Q_T = 4.94 - 17.4 X_T \quad \dots(15.16)$

The computations are made for Lower Tapi river at Ukai as per Ven Te Cow method, below.

| T (yr) | $X_T =$ $\log \left(\log \frac{T}{T-1} \right)$ | $Q_T =$ $4.94 - 17.4 X_T$ (tcm) | $P = \frac{1}{T} \times 100$ (%) |
|-------------|---|---------------------------------------|-------------------------------------|
| 1000 | -3.361 | 63.44 | 0.1 |
| 200 | -2.662 | 51.34 | 0.5 |
| 100 | -2.360 | 46.04 | 1 |
| 50 | -2.056 | 40.64 | 2 |
| 10 | -1.339 | 28.29 | 10 |
| 2 | -0.521 | 14.02 | 50 |

15.2 STOCHASTIC METHOD

Annual Floods: The methods described earlier were either probabilistic or deterministic, and did not consider the element of time which is possible only by the stochastic approach. Work in the field of stochastic hydrology has been introduced in USA by Yevdjevich, Ven Te Chow and others. One of the well known equations based on annual flood data using Poisson probability law and theory of sums of random number of random variables is

$$Q_T = Q_{\min} + 2.3 (\bar{Q} - Q_{\min}) \log \left(\frac{n_f}{n} \cdot T \right) \quad \dots(15.17)$$

where $T = \frac{n}{m}$

n_f = number of recorded floods, counting only one for the same flood peak occurring in different years.

Computations are made by using Eq. (15.17) for the lower Tapti river at Ukai, below. Here $n_f = n = 30$, $\bar{Q} = 14.21$ tcm, $Q_{\min} = 3.68$ tcm

$$\therefore Q_T = 3.68 + 2.3 (14.21 - 3.68) \log \left(\frac{30}{30} \cdot T \right)$$

or, $Q_T = 3.68 + 24.26 \log T \quad \dots(15.18)$

| T (yr) | $\log T$ | $24.26 \log T$ | $Q_T =$ $3.68 + 24.26 \log T$ (tcm) |
|-------------|----------|----------------|---|
| 1000 | 3.0 | 72.78 | 76.46 |
| 200 | 2.3010 | 56.00 | 59.68 |
| 100 | 2.0 | 48.52 | 52.20 |
| 50 | 1.6990 | 41.25 | 44.93 |
| 10 | 1.0 | 24.26 | 27.94 |
| 2 | 0.3010 | 7.32 | 11.00 |

The highest annual flood peak attained in the lower Tapti river during 1876-1968 (93 years) was 42.5 tcm. From Fig. 15.1, the 100-yr flood given by Gumbel's method is 49.21 tcm, 44.61 tcm by Powell's, 45.46 tcm by Foster's-Type I [Ex. 8.5 (b)] 46.04 tcm by Chow's and 52.20 tcm by stochastic method. The Fuller's method gives 37.0 tcm, which is exceeded. Hence the Gumbel's method gives the most probable maximum flood in the life period of structure and can be adopted as Standard Project Flood (SPF) for the design of the structure, while the stochastic method seems to predict to some extent the Maximum Probable Flood (MPF). Actually the SPF and MPF recommended by CWPC, India for the design of Ukai dam, were 48.2 tcm and 59.8 tcm, respectively. The peak of the flood hydrograph obtained by the application of the 6-hr design unit hydrograph in Example 8.4 was also 59.8 tcm.

15.3 STOCHASTIC MODELLING BY THE PARTIAL DURATION SERIES

Sharma et al. (1975) gave a new model using the partial duration series, *i.e.*, flood peaks above a given base level (Q_b), to derive the distribution of the largest floods (peak flows) in a given

time interval $(0, t)$. The magnitude of these peaks are considered as a series of random variables. The base flow Q_b may be taken as the bankfull discharge of the river at the particular station. If Q_i is the flood peak, which has occurred in the time interval $(0, t)$, then the flood exceedance x_i in this interval is

$$x_i = Q_i - Q_b \quad \dots(15.19)$$

The number $n(t)$ of flood exceedances in an interval of time $(0, t)$ as well as the magnitudes of the exceedances $x(t)$, are time, dependent-random variables. The time T_i of occurrence of these exceedances are also random variables. The time T_i is associated with the random variables x_i for $i = 1, 2, 3, \dots n$.

Todorovic and Emir Zelenhasic (1970) have developed the distribution function $F_t(x)$ of the largest exceedance in a given interval of time $(0, t)$ as

$$F_t(x) = \exp(-\lambda t e^{-\beta x}) \quad \dots(15.20)$$

and the probability of occurrence of exceedances x_i during the interval $(0, t)$ as

$$H(x) = 1 - \exp(-\beta x) \quad \dots(15.21)$$

For a particular exceedance x_T for an interval of T years

$$F(x_T) = \exp[-\lambda T e^{-\beta x_T}] \quad \dots(15.22)$$

where λ and β are constants for a particular series of data (λ = average number of exceedances per year).

If $x_T \geq 0$ for $T \geq 0$, then $F(x_T)$ will represent the probability of occurrence of an exceedance x_T and

$$F(x_T) = \frac{1}{\lambda T} \quad \dots(15.23)$$

From eqs. (15.22) and (15.23), the new mathematical model is obtained as

$$x_T = \frac{1}{\beta} [\ln(\lambda T) - \ln\{\ln(\lambda T)\}] \quad \dots(15.24)$$

Then, the design flood Q_T may be obtained as

$$Q_T = Q_b + x_T \quad \dots(15.25)$$

Example 15.1 *Flood data in the form of Partial-Duration Series and Annual-Flood Peaks for the Ganga river at Hardwar for a period of 87 years (1885-1971) are given in Tables 15.4 and 15.5, respectively. The base flow for the partial duration series may be taken as 4333 cumec (which was accepted as the bankfull discharge in the design of weir at Bhimgoda).*

Derive the flood-frequency curves based on the two series by using the stochastic models. Make a comparative study with the other methods based on annual floods discussed earlier.

[**Note** *Partial duration series data for the Lower Tapti river at Ukai could not be obtained and hence flood data for the Ganga river is given here*].

Table 15.4. Partial duration series of floods for the river Ganga at Hardwar during 1885-1971 (87 years).
Base flow, $Q_b = 4333$ cumec, $Q =$ Flood peak, $x =$ Flood peak exceedance. (Example 15.1).

| <i>St. no.</i> | <i>Year</i> | <i>Cumec</i> | <i>June</i> | <i>Dt.</i> | <i>July</i> | <i>Dt.</i> | <i>Aug.</i> | <i>Dt.</i> | <i>Sept.</i> | <i>Dt.</i> | <i>Oct.</i> | <i>Dt.</i> |
|----------------|-------------|--------------|-------------|------------|-------------|------------|-------------|------------|--------------|------------|-------------|------------|
| <i>1</i> | <i>2</i> | <i>3</i> | <i>4</i> | <i>5</i> | <i>6</i> | <i>7</i> | <i>8</i> | <i>9</i> | <i>10</i> | <i>11</i> | <i>12</i> | <i>13</i> |
| 1. | 1885 | Q | | | 5814 | 16 | 7241 | 9 | | | | |
| | | x | | | 1481 | | 2908 | | | | | |
| 2. | 1886 | Q | | | 4665 | 15 | 9163 | 5 | 6018 | 2 | | |
| | | x | | | 332 | | 4831 | | 1685 | | | |
| | | Q | | | 4848 | 22 | | | | | | |
| | | x | | | 515 | | | | | | | |
| | | Q | | | 4369 | 27 | | | | | | |
| | | x | | | 36 | | | | | | | |
| 3. | 1887 | Q | | | | | 5882 | 2 | | | | |
| | | x | | | | | 1549 | | | | | |
| | | Q | | | | | 7407 | 22 | | | | |
| | | x | | | | | 3074 | | | | | |
| 4. | 1888 | Q | | | 5417 | 22 | 4848 | 2 | 5417 | 3 | | |
| | | x | | | 1084 | | 515 | | 1084 | | | |
| | | Q | | | 5034 | 27 | | | 6870 | 20 | | |
| | | x | | | 701 | | | | 2537 | | | |
| | | Q | | | 4909 | 31 | | | | | | |
| | | x | | | 576 | | | | | | | |
| 5. | 1889 | Q | | | 7936 | 7 | 7546 | 3 | 4971 | 9 | | |
| | | x | | | 3603 | | 3213 | | 638 | | | |
| | | Q | | | 4848 | 17 | 9855 | 15 | | | | |
| | | x | | | 515 | | 5522 | | | | | |
| | | Q | | | 8827 | 29 | 7857 | 29 | | | | |
| | | x | | | 4494 | | 3524 | | | | | |

(Contd.)...

| 1 | 2 | 3 | 4 | 5 | 6 | 7 | 8 | 9 | 10 | 11 | 12 | 13 |
|-----|------|---|---|------|--|---------------------|--|---------------------|--------------|----|-------------|----|
| 6. | 1890 | Q | | | 5814 1481 11887 7554 | 19 30 | 6508 2175 9249 4916 5417 1084 8827 4494 5747 1414 7546 3213 | 7 19 31 14 | 4971 608 | 3 | | |
| 7. | 1891 | Q | | | 4786 453 | 26 | | | | | | |
| 8. | 1892 | Q | | | 4605 272 | 26 | 5747 1414 7546 | 15 25 | 4971 608 | 3 | | |
| 9. | 1893 | Q | | 5287 | 5482 1149 | 26 | 6087 1754 6870 2537 | 4 10 | 8498 4165 | 5 | 5128 795 | 19 |
| 10. | 1894 | Q | | | 5160 827 6018 1685 9767 5434 13179 | 8 21 27 30 | 10032 5699 9680 5347 16757 12424 | 6 12 26 | 7376 3043 | 6 | | |
| 11. | 1895 | Q | | | 8846 5747 1414 | 2 | 9680 5347 | 13 | 5034 701 | 8 | | |

(Contd.)...

| 1 | 2 | 3 | 4 | 5 | 6 | 7 | 8 | 9 | 10 | 11 | 12 | 13 |
|-----|------|---|---|------|----|---|-------|----|------|----|----|----|
| 12 | 1896 | Q | | | | | 14336 | 10 | | | | |
| | | x | | | | | 10003 | | | | | |
| 13. | 1897 | Q | | 7623 | 22 | | 7407 | 5 | 4427 | 3 | | |
| | | x | | 3290 | | | 3074 | | 94 | | | |
| | | Q | | | | | 8174 | 23 | | | | |
| | | x | | | | | 3841 | | | | | |
| 14. | 1898 | Q | | 5814 | 10 | | 8953 | 12 | 6366 | 7 | | |
| | | x | | 1481 | | | 4620 | | 2033 | | | |
| | | Q | | 5882 | 24 | | 7241 | 18 | | | | |
| | | x | | 1549 | | | 2908 | | | | | |
| 15. | 1899 | Q | | 7546 | 23 | | | | | | | |
| | | x | | 3213 | | | | | | | | |
| 16. | 1900 | Q | | 4486 | 17 | | 6651 | 11 | 5950 | 6 | | |
| | | x | | 153 | | | 2318 | | 1617 | | | |
| | | Q | | | | | 5097 | 26 | 4786 | 12 | | |
| | | x | | | | | 764 | | 453 | | | |
| 17. | 1901 | Q | | 4427 | 19 | | 7700 | 8 | | | | |
| | | x | | 94 | | | 3367 | | | | | |
| | | Q | | | | | 11409 | 24 | | | | |
| | | x | | | | | 7076 | | | | | |
| 18. | 1902 | Q | | | | | 9163 | 3 | 4848 | 14 | | |
| | | x | | | | | 4830 | | 515 | | | |
| 19. | 1903 | Q | | | | | 7407 | 14 | | | | |
| | | x | | | | | 3074 | | | | | |
| | | Q | | | | | 6296 | 27 | | | | |
| | | x | | | | | 1963 | | | | | |
| 20. | 1904 | Q | | 8579 | 29 | | 7092 | 3 | | | | |
| | | x | | 4246 | | | 2759 | | | | | |

(Contd.)...

| 1 | 2 | 3 | 4 | 5 | 6 | 7 | 8 | 9 | 10 | 11 | 12 | 13 |
|-----|------|---|------|------|-------|----|-------|----|------|----|-------|----|
| | | Q | | | | | 7091 | 12 | | | | |
| | | x | | | | | 2758 | | | | | |
| | | Q | | | | | 7017 | 21 | | | | |
| | | x | | | | | 2684 | | | | | |
| 21. | 1905 | Q | | | | | 9362 | 13 | | | | |
| | | x | | | | | 5029 | | | | | |
| 22. | 1906 | Q | | 7092 | 28 | | 6870 | 3 | 6226 | 16 | | |
| | | x | | 2759 | | | 2537 | | 1893 | | | |
| | | Q | | | | | 5950 | 19 | | | | |
| | | x | | | | | 1617 | | | | | |
| 23. | 1907 | Q | | 7546 | 30 | | 7241 | 3 | | | | |
| | | x | | 3213 | | | 2908 | | | | | |
| 24. | 1908 | Q | | 6651 | 13 | | 11504 | 2 | | | | |
| | | x | | 2318 | | | 7171 | | | | | |
| | | Q | | | | | 5949 | 21 | | | | |
| | | x | | | | | 1616 | | | | | |
| | | Q | | | | | 6018 | 29 | | | | |
| | | x | | | | | 1685 | | | | | |
| 25. | 1909 | Q | | 6870 | 16 | | 7407 | 12 | | | | |
| | | x | | 2537 | | | 3074 | | | | | |
| | | Q | | 8335 | 21 | | 6724 | 20 | | | | |
| | | x | | 4002 | | | 2391 | | | | | |
| | | Q | | | | | 5949 | 27 | | | | |
| | | x | | | | | 1616 | | | | | |
| 26. | 1910 | Q | 4605 | 15 | 10121 | 28 | 7469 | 3 | 6156 | 11 | 15077 | 3 |
| | | x | 272 | | 5788 | | 3136 | | 1823 | | 10744 | |
| | | Q | | | | | 11887 | 13 | | | | |
| | | x | | | | | 7554 | | | | | |

(Contd.)...

| <i>I</i> | <i>2</i> | <i>3</i> | <i>4</i> | <i>5</i> | <i>6</i> | <i>7</i> | <i>8</i> | <i>9</i> | <i>10</i> | <i>11</i> | <i>12</i> | <i>13</i> |
|----------|----------|----------|----------|----------|----------|----------|----------|----------|-----------|-----------|-----------|-----------|
| | | Q | | | | | 7091 | 18 | | | | |
| | | x | | | | | 2759 | | | | | |
| 27. | 1911 | Q | | | | | 6943 | 18 | 4369 | 13 | | |
| | | x | | | | | 2610 | | 36 | | | |
| 28. | 1912 | Q | | | | | 7700 | 16 | 8335 | 2 | | |
| | | x | | | | | 3367 | | 4002 | | | |
| 29. | 1914 | Q | | | 5417 | 2 | | | 9249 | 19 | | |
| | | x | | | 1084 | | | | 4916 | | | |
| | | Q | | | 6018 | 28 | | | | | | |
| | | x | | | 1685 | | | | | | | |
| 30 | 1915 | Q | | | | | 6579 | 2 | | | | |
| | | x | | | | | 2246 | | | | | |
| | | Q | | | | | 7407 | 13 | | | | |
| | | x | | | | | 3074 | | | | | |
| | | Q | | | | | 4725 | 29 | | | | |
| | | x | | | | | 392 | | | | | |
| 31. | 1916 | Q | | | | | 4725 | 26 | | | | |
| | | x | | | | | 392 | | | | | |
| 32. | 1917 | Q | | | 8416 | 11 | 5352 | 5 | 5482 | 9 | | |
| | | x | | | 4083 | | 1019 | | 1149 | | | |
| | | Q | | | 6870 | 25 | 4909 | 23 | | | | |
| | | x | | | 2537 | | 576 | | | | | |
| 33. | 1918 | Q | | | | | 4665 | 22 | | | | |
| | | x | | | | | 332 | | | | | |
| 34. | 1919 | Q | | | 6296 | 13 | | | 5160 | 7 | | |
| | | x | | | 1963 | | | | 827 | | | |
| 35. | 1920 | Q | | | 4848 | 23 | 8174 | 14 | | | | |
| | | x | | | 515 | | 3841 | | | | | |

(Contd.)...

| 1 | 2 | 3 | 4 | 5 | 6 | 7 | 8 | 9 | 10 | 11 | 12 | 13 |
|-----|------|--------|--------------|----|--------------|----|---|----------|-------------------------------|---------|----|----|
| 36. | 1921 | Q x | 5680 1347 | 26 | | | 7623 3290 9079 4746 | 4 18 | 6508 2175 5950 1617 | 9 15 | | |
| 37. | 1922 | Q | | | 5814 1481 | 20 | 7407 3074 5482 1149 | 17 5 | 5034 701 | 3 | | |
| 38. | 1923 | x | | | | | 6087 1754 5097 764 | 3 19 | 4848 515 19136 14803 | 5 29 | | |
| 39. | 1924 | Q x | | | 5160 827 | 27 | | | | | | |
| 40. | 1925 | Q | | | 5160 827 | 21 | 9670 5347 7236 2903 7241 2908 4545 212 | 12 5 | | | | |
| 41. | 1927 | x | | | | | | | | | | |
| 42. | 1929 | Q | | | | | | | | | | |
| 43. | 1930 | x | | | 5443 1110 | 27 | 5997 1664 5532 1199 6155 1822 | 21 14 | | | | |
| 44. | 1932 | Q | | | | | | | | | | |
| 45. | 1933 | Q | | | 4692 359 | 25 | 5267 934 | 15 | | | | |

(Contd.)...

| 1 | 2 | 3 | 4 | 5 | 6 | 7 | 8 | 9 | 10 | 11 | 12 | 13 |
|-----|------|---|---|---|------|----|------|----|------|----|------|----|
| 46. | 1934 | Q | | | | | 6193 | 21 | | | | |
| | | x | | | | | 1860 | | | | | |
| 47. | 1935 | Q | | | | | 5289 | 4 | | | | |
| | | x | | | | | 956 | | | | | |
| 48. | 1942 | Q | | | 4887 | 24 | 6650 | 9 | | | | |
| | | x | | | 554 | | 2317 | | | | | |
| 49. | 1943 | Q | | | | | 4442 | 22 | | | | |
| | | x | | | | | 109 | | | | | |
| 50. | 1945 | Q | | | | | 4836 | 19 | 5101 | 3 | | |
| | | x | | | | | 503 | | 768 | | | |
| 51. | 1946 | Q | | | 4629 | 28 | | | | | | |
| | | x | | | 296 | | | | | | | |
| 52. | 1947 | Q | | | | | | | 4345 | 27 | | |
| | | x | | | | | | | 12 | | | |
| 53. | 1948 | Q | | | | | 4890 | 25 | | | | |
| | | x | | | | | 557 | | | | | |
| 54. | 1950 | Q | | | 4562 | 26 | 5899 | 18 | | | | |
| | | x | | | 229 | | 1566 | | | | | |
| 55. | 1951 | Q | | | | | 4458 | 22 | 4339 | 15 | | |
| | | x | | | | | 125 | | 6 | | | |
| 56. | 1953 | Q | | | | | 5470 | 13 | | | | |
| | | x | | | | | 1137 | | | | | |
| 57. | 1954 | Q | | | | | 5978 | 20 | | | | |
| | | x | | | | | 1645 | | | | | |
| 58. | 1955 | Q | | | | | | | | | 4644 | 5 |
| | | x | | | | | | | | | 311 | |
| 59. | 1956 | Q | | | | | | | | | 6381 | 11 |
| | | x | | | | | | | | | 2048 | |

(Contd.)...

| 1 | 2 | 3 | 4 | 5 | 6 | 7 | 8 | 9 | 10 | 11 | 12 | 13 |
|-----|------|---|---|---|------|----|------|----|------|----|----|----|
| 60. | 1957 | Q | | | | | | | 4548 | 15 | | |
| | | x | | | | | | | 213 | | | |
| 61. | 1959 | Q | | | | | 4493 | 3 | | | | |
| | | x | | | | | 160 | | | | | |
| 62. | 1961 | Q | | | | | 4855 | 17 | | | | |
| | | x | | | | | 522 | | | | | |
| 63. | 1962 | Q | | | 5760 | 28 | | | | | | |
| | | x | | | 1427 | | | | | | | |
| 64. | 1963 | Q | | | | | 5574 | 21 | 9192 | 17 | | |
| | | x | | | | | 1241 | | 4859 | | | |
| 65. | 1966 | Q | | | 4741 | 26 | | | | | | |
| | | x | | | 408 | | | | | | | |
| 66. | 1967 | Q | | | | | 5919 | 27 | | | | |
| | | x | | | | | 1586 | | | | | |
| 67. | 1969 | Q | | | | | 4546 | 20 | | | | |
| | | x | | | | | 213 | | | | | |
| 68. | 1971 | Q | | | | | 4542 | 7 | | | | |
| | | x | | | | | 209 | | | | | |

Table 15.5 Annual Peak discharges for Ganga river at Hardwar
for the period 1885-1971 (87 yrs) (Example 15.1)

| <i>Sl. no.</i> | <i>Year</i> | <i>Ann. Peak Q (cumec)</i> | <i>Log₁₀ Q</i> | <i>Sl. no.</i> | <i>Year</i> | <i>Ann. Peak Q (cumec)</i> | <i>Log₁₀ Q</i> |
|----------------|-------------|----------------------------|---------------------------|----------------|-------------|----------------------------|---------------------------|
| 1. | 1885 | 7241 | 3.8598 | 37. | 1921 | 9079 | 3.9580 |
| 2. | 1886 | 9164 | 3.9621 | 38. | 1922 | 7407 | 3.8696 |
| 3. | 1887 | 7407 | 3.8696 | 39. | 1923 | 5482 | 3.7390 |
| 4. | 1888 | 6870 | 3.8370 | 40. | 1924 | 19136 | 4.2818 |
| 5. | 1889 | 9855 | 3.9936 | 41. | 1925 | 9680 | 3.9859 |
| 6. | 1890 | 11887 | 4.0752 | 42. | 1926 | 3698 | 3.5680 |
| 7. | 1891 | 8827 | 3.9458 | 43. | 1927 | 7241 | 3.8598 |
| 8. | 1892 | 7546 | 3.8777 | 44. | 1928 | 3698 | 3.5680 |
| 9. | 1893 | 8498 | 3.9293 | 45. | 1929 | 4545 | 3.6576 |
| 10. | 1894 | 16757 | 4.2242 | 46. | 1930 | 5998 | 3.7780 |
| 11. | 1895 | 9680 | 3.9859 | 47. | 1931 | 3470 | 3.5403 |
| 12. | 1896 | 14336 | 4.1565 | 48. | 1932 | 6155 | 3.7893 |
| 13. | 1897 | 8174 | 3.9124 | 49. | 1933 | 5267 | 3.7216 |
| 14. | 1898 | 8953 | 3.9518 | 50. | 1934 | 6193 | 3.7919 |
| 15. | 1899 | 7546 | 3.8777 | 51. | 1935 | 5289 | 3.7223 |
| 16. | 1900 | 6652 | 3.8229 | 52. | 1936 | 3320 | 3.5211 |
| 17. | 1901 | 11409 | 4.0573 | 53. | 1937 | 3232 | 3.5095 |
| 18. | 1902 | 9164 | 3.9621 | 54. | 1938 | 3525 | 3.5471 |
| 19. | 1903 | 7404 | 3.8694 | 55. | 1939 | 2341 | 3.3694 |
| 20. | 1904 | 8579 | 3.9335 | 56. | 1940 | 2429 | 3.3854 |
| 21. | 1905 | 9362 | 3.9714 | 57. | 1941 | 3154 | 3.4989 |
| 22. | 1906 | 7092 | 3.8507 | 58. | 1942 | 6650 | 3.8228 |
| 23. | 1907 | 7546 | 3.8777 | 59. | 1943 | 4442 | 3.6476 |
| 24. | 1908 | 11504 | 4.0607 | 60. | 1944 | 4229 | 3.6262 |
| 25. | 1909 | 8335 | 3.9209 | 61. | 1945 | 5101 | 3.7077 |
| 26. | 1910 | 15077 | 4.1783 | 62. | 1946 | 4629 | 3.6654 |
| 27. | 1911 | 6943 | 3.8416 | 63. | 1947 | 4345 | 3.6380 |
| 28. | 1912 | 8335 | 3.9209 | 64. | 1948 | 4890 | 3.6893 |
| 29. | 1913 | 3579 | 3.5538 | 65. | 1949 | 3619 | 3.5586 |
| 30. | 1914 | 9299 | 3.9684 | 66. | 1950 | 5899 | 3.7708 |
| 31. | 1915 | 7407 | 3.8696 | 67. | 1951 | 4458 | 3.6492 |
| 32. | 1916 | 4726 | 3.6744 | 68. | 1952 | 3919 | 3.5932 |
| 33. | 1917 | 8416 | 3.9251 | 69. | 1953 | 5470 | 3.7380 |
| 34. | 1918 | 4668 | 3.6698 | 70. | 1954 | 5978 | 3.7766 |
| 35. | 1919 | 6296 | 3.7991 | 71. | 1955 | 4644 | 3.6669 |
| 36. | 1920 | 8174 | 3.9124 | 72. | 1956 | 6381 | 3.8049 |

(Contd.)...

| | | | | | | | |
|-----|------|------|--------|-----|------|------|--------|
| 73. | 1957 | 4548 | 3.6579 | 81. | 1965 | 2509 | 3.3994 |
| 74. | 1958 | 4056 | 3.6081 | 82. | 1966 | 4741 | 4.6759 |
| 75. | 1959 | 4493 | 3.6525 | 83. | 1967 | 5919 | 3.7725 |
| 76. | 1960 | 3884 | 3.5893 | 84. | 1968 | 3798 | 3.5795 |
| 77. | 1961 | 4855 | 3.6861 | 85. | 1969 | 4546 | 3.6577 |
| 78. | 1962 | 5760 | 3.7604 | 86. | 1970 | 3842 | 3.5845 |
| 79. | 1963 | 9192 | 3.9634 | 87. | 1971 | 4542 | 3.6573 |
| 80. | 1964 | 3024 | 3.4806 | | | | |

Solution The histogram of annual flood peaks for the Ganga river at Hardwar for the period 1885-1971, 87 years, is shown in Fig. 15.2. The computation of the cumulative frequency curve is made in Table 15.6.

It is seen that the distribution of floods do not have the normal bell-shaped curve but they are skewed. However, the data can be transformed by plotting the common logarithm of the flood peaks so that the distribution density curve is approximately normal as shown in Fig. 15.3. This is then called a *log normal distribution* and the standard deviation is in logarithmic units. The histogram of the partial-duration series of the flood peaks above the selected base of 4333 cumec is shown in Fig. 15.4, which also represents skewed data.

Table 15.6 Computation of the cumulative frequency curve

| <i>Annual flood peak</i> C.I. (1000 cumec) | <i>No. of occurrences</i> or <i>frequency, f</i> | <i>Cumulative occurrences</i> or <i>frequency, CF</i> | <i>Probability</i> $\left(= \frac{CF}{\Sigma f} \times 100 \right) \%$ |
|--|--|---|--|
| 0-2* | 0 | 87 | 100 |
| 2-4* | 17 | 87 | 100 |
| 4-6 | 27 | 70 | 80.5 |
| 6-8 | 18 | 43 | 49.5 |
| 8-10 | 18 | 25 | 28.8 |
| 10-12 | 3 | 7 | 8.05 |
| 12-14 | 0 | 4 | 4.6 |
| 14-16 | 2 | 4 | 4.6 |
| 16-18 | 1 | 2 | 2.3 |
| 18-20 | 1 | 1 | 1.15 |
| | $\Sigma f = 87$ | | |

*0-<2.

2- <4, and like that.

(a) **Partial duration series.** There are 175 flood exceedances (above Q_b) during 87 years. Average number of exceedances per year.

$$\lambda = \frac{175}{87} = 2.01$$

Parameter β is estimated in the following Table.

| Sl. no. | Flood peak exceedance x_i (cumec) | | Observed frequency | Cumulative frequency | $H(x) = \frac{CF}{175}$ | $1 - H(x)$ | $\beta = \frac{-\ln\{1 - H(x)\}}{x \dots \times 10^{-4}}$ |
|---------|-------------------------------------|----------|--------------------|----------------------|-------------------------|------------|---|
| | CI | Variable | | CF | | | |
| 1. | below-2500 | 2500 | 107 | 107 | 0.6114 | 0.3886 | 3.362 |
| 2. | 2500-5000 | 5000 | 51 | 158 | 0.9029 | 0.0971 | 4.649 |
| 3. | 5000-7500 | 7500 | 10 | 168 | 0.9600 | 0.0400 | 4.282 |
| 4. | 7500-10000 | 10000 | 3 | 171 | 0.9771 | 0.0229 | 3.762 |
| 5. | 10000-12500 | 12500 | 3 | 174 | 0.9443 | 0.0057 | 4.119 |
| 6. | 12500-15000 | 15000 | 1 | 175 | 1.0000 | 0.0000 | — |

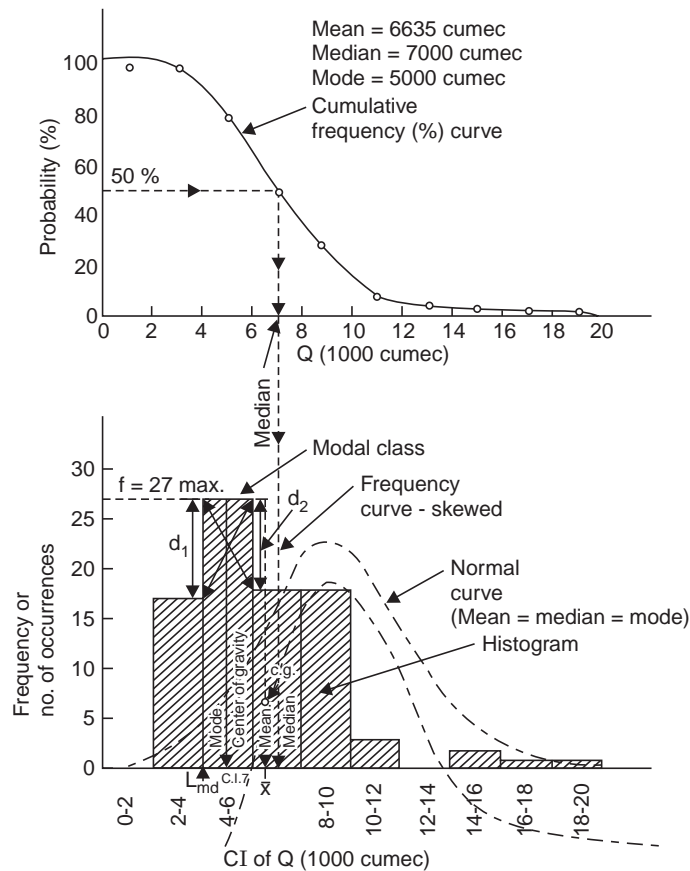

Fig. 15.2 Histogram of annual floods of river Ganga (1885-1971)

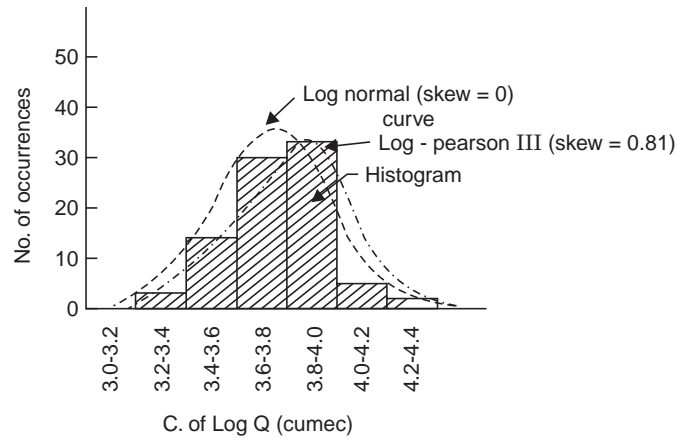

Fig. 15.3 Histogram of logarithm of annual floods of river Ganga (1885-1971)

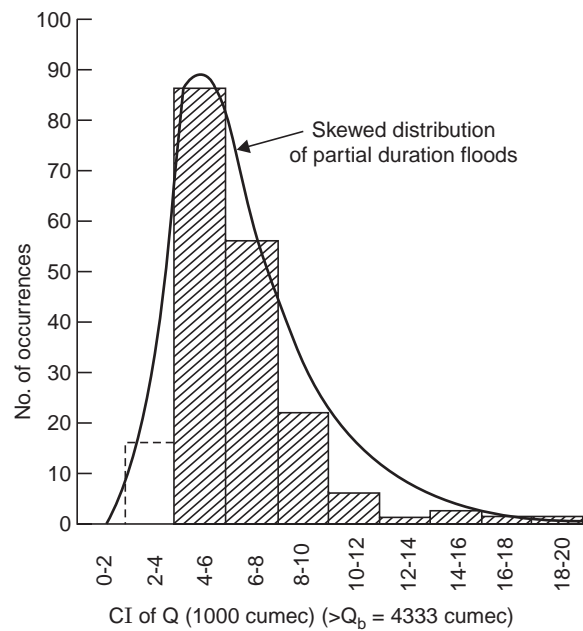

Fig. 15.4 Histogram of partial duration floods in river Ganga (1885–1971)

The average value of $\beta = \hat{\beta} = 4.05 \times 10^{-4}$

Estimation of design flood can now be done from Eqs. (15.24) and (15.25)

$$Q_T = Q_b + x_T$$

$$\therefore Q_T = 4333 + \frac{10^4}{4.05} [\ln (2.01 T) - \ln \{\ln (2.01 T)\}] \quad \dots(15.26)$$

| | | | | | |
|--------------------------------|-------|-------|-------|-------|-------|
| T -yr: | 1000 | 500 | 200 | 100 | 50 |
| Q_T (cumec): | 18103 | 16605 | 14728 | 13296 | 11938 |
| Q_T by $T = \frac{n+1}{m}$: | 23600 | 21600 | 18900 | 17000 | 15100 |

15.4 ANNUAL FLOOD PEAKS—RIVER GANGA

(i) Gumbel's method Eq. (15.6):

$$Q_T = \bar{Q} + K\sigma$$

$$\bar{Q} = 6635.63 \text{ cumec}, \sigma = 3130.8 \text{ cumec}$$

$$K = \frac{y - \bar{y}_n}{\sigma_n}$$

From Table 15.5 for $n = 87$, $\bar{y}_n = 0.55815$, $\sigma_n = 1.1987$

| $T\text{-yr}$ | $X_T = \log \left(\frac{T}{T-1} \right)$ | $Y = -0.834 - 2.3 X_T$ | $K = \frac{y - \bar{y}_n}{\sigma_n}$ | $Q_T = \bar{Q} + K\sigma$ |
|---------------|---|------------------------|--------------------------------------|---------------------------|
| 1000 | - 3.361 | 6.907 | 5.29 | 23185 |
| 500 | - 3.060 | 6.213 | 4.7 | 21335 |
| 200 | - 2.662 | 5.295 | 3.95 | 19005 |
| 100 | - 2.360 | 4.600 | 3.36 | 17155 |
| 50 | - 2.056 | 3.901 | 2.79 | 15365 |

(ii) Stochastic Method Eq. (15.17):

$$Q_{\min} = 2341 \text{ cumec}; \bar{Q} = 6635.63 \text{ cumec}; n_f = 77$$

$$Q_T = Q_{\min} + 2.3 (\bar{Q} - Q_{\min}) \log \left(\frac{n_f \cdot T}{n} \right)$$

$$= 2341 + 2.3 (6635.63 - 2341) \log \left(\frac{77}{87} \cdot T \right)$$

$$\therefore Q_T = 2341 + 9890 \log (0.885 T) \quad \dots(15.27)$$

| $T\text{-yr}$ | $0.885 T$ | $\log (0.885 T)$ | $9890 \log (0.885 T)$ | Q_T cumec |
|---------------|-----------|------------------|-----------------------|----------------|
| 1000 | 885 | 2.947 | 29200 | 31541 |
| 500 | 442.5 | 2.646 | 26200 | 28541 |
| 200 | 177 | 2.248 | 22200 | 24541 |
| 100 | 88.5 | 1.947 | 19200 | 21541 |
| 50 | 44.25 | 1.646 | 16260 | 18601 |

(iii) Log-Pearson Type III distribution. For the grouped data of annual floods in Table 15.7, computations are made in Table 15.5 to obtain the statistical parameters of the Log-Pearson Type-III distribution [see Eqs. (14.27 a, b, c)].

$$\text{Mean:} \quad \overline{\log x} = \frac{\Sigma f(\log x)}{\Sigma f} = \frac{67.3856}{87} = 0.7750$$

$$\text{Std. dev:} \quad \sigma_{\log x} = \sqrt{\frac{\Sigma f(\log x - \overline{\log x})^2}{n - 1}} = \sqrt{\frac{3.3315}{87 - 1}} = 0.1962$$

Table 15.7. Log-Pearson Type-III distribution for the annual floods of river Ganga (1885-1971) (Example 15.1)

| CI (1000 cumec) | Mid-pt. of CI <i>x</i> (1000 cumec) | Frequency <i>f</i> | <i>log x</i> | <i>f log x</i> | $\frac{\log x}{-\overline{\log x}}$ | $\frac{(\log x)^2}{-\overline{\log x}^2}$ | $\frac{(\log x)^3}{-\overline{\log x}^3}$ | $\frac{f(\log x)^2}{-\overline{\log x}^2}$ | $\frac{f(\log x)^3}{-\overline{\log x}^3}$ |
|-----------------------|---|-----------------------|------------------------------------|----------------|-------------------------------------|---|---|--|--|
| 0-2 | 1 | 0 | 0 | 0 | 0 | 0 | 0 | 0 | 0 |
| 2-4 | 3 | 17 | 0.4771 | 8.1000 | -0.2979 | -0.0890 | -0.0265 | 1.5120 | -0.4500 |
| 4-6 | 5 | 27 | 0.6990 | 18.9000 | -0.0760 | 0.0058 | -0.00044 | 0.1560 | -0.0119 |
| 6-8 | 7 | 18 | 0.8451 | 15.2000 | 0.0701 | 0.0049 | 0.0003 | 0.0885 | 0.0062 |
| 8-10 | 9 | 18 | 0.9542 | 17.2000 | 0.1792 | 0.0340 | 0.0057 | 0.5790 | 0.1025 |
| 10-12 | 11 | 3 | 1.0414 | 3.1242 | 0.2664 | 0.0710 | 0.0190 | 0.2130 | 0.0570 |
| 12-14 | 13 | 0 | 1.1139 | 0.0000 | 0.3389 | 0.1150 | 0.0390 | 0.0000 | 0.0000 |
| 14-16 | 15 | 2 | 1.1761 | 2.3522 | 0.4011 | 0.1610 | 0.0644 | 0.3220 | 0.1288 |
| 16-18 | 17 | 1 | 1.2304 | 1.2304 | 0.4554 | 0.2070 | 0.0940 | 0.2070 | 0.0940 |
| 18-20 | 19 | 1 | 1.2788 | 1.2788 | 0.5038 | 0.2540 | 0.1280 | 0.2540 | 0.1280 |
| Σ | | $n = \Sigma f = 87$ | $\Sigma f \cdot \log(x) = 67.3856$ | | | | | 3.3315 | 0.5165 |

For grouped data: $\overline{\log x} = \frac{\Sigma f \cdot \log(x)}{\Sigma f} = \frac{67.3856}{87} = 0.7750$

Skew:
$$g = \frac{n \Sigma f(\log x - \overline{\log x})^3}{(n-1)(n-2)(\sigma_{\log x})^3} = \frac{87(0.5165)}{(87-1)(87-2)(0.1962)^3} = 0.81$$

Putting variate $x =$ flood peak $Q(1000 \text{ cumec})$, the distribution Eq. (14.28) becomes

$$\log Q_T = \overline{\log Q} + K\sigma_{\log Q} \quad \dots(15.28)$$

and Q_T for any desired T can be computed by knowing the value of K for $g = 0.81$ and desired T from Table 14.2.

| T -yr | $K = f(g, T)$ from Table 14.2 | $K \cdot \sigma_{\log Q}$ ($\sigma_{\log Q} = 0.1962$) | $\log Q_T$ $= \overline{\log Q} + K\sigma_{\log Q}$ ($\overline{\log Q} = 0.7750$) | Q_T (1000 cumec) |
|---------|-------------------------------------|---|--|-----------------------|
| 2 | -0.132 | -0.0259 | 0.7491 | 5.611 |
| 5 | 0.779 | 0.1530 | 0.9280 | 8.472 |
| 10 | 1.336 | 0.2620 | 1.0370 | 10.89 |
| 25 | 1.996 | 0.3910 | 1.1660 | 14.66 |
| 50 | 2.458 | 0.4820 | 1.2570 | 18.07 |
| 100 | 2.898 | 0.5670 | 1.3420 | 21.98 |
| 200 | 3.321 | 0.6500 | 1.4250 | 26.61 |

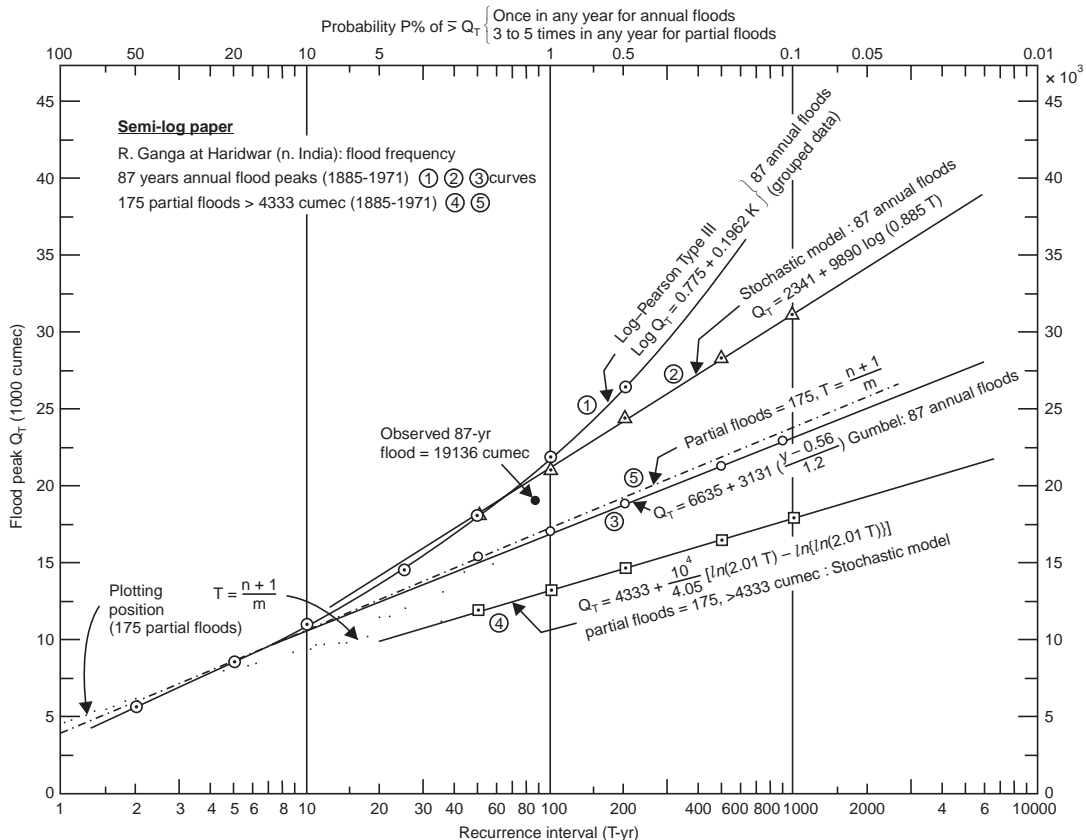

Fig. 15.5 Flood-frequency curves of River Ganga at Hardwar (1885-1971)

The frequency curve Q_T vs. T is drawn on log-log paper (Fig. 15.6) and also compared with other well known distributions in Fig. 15.5. Chow (1951) has shown that most frequency distributions can be generalised as

$$Q_T = \bar{Q} + K\sigma_Q \quad \dots(15.29)$$

where K is the frequency factor.

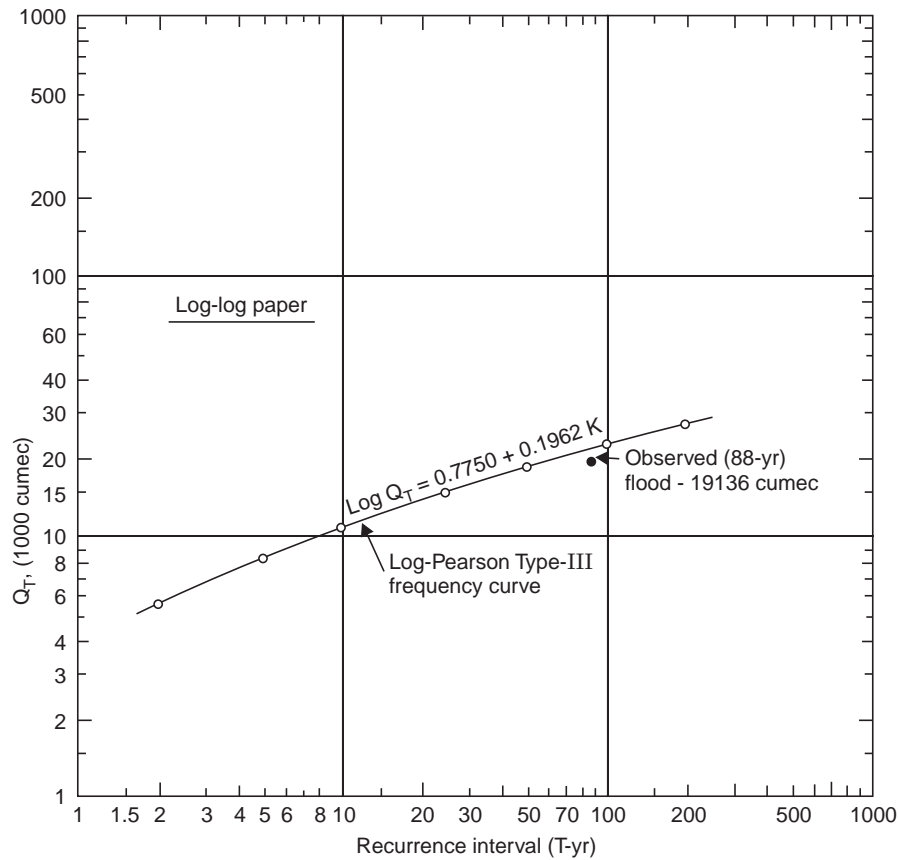

Fig. 15.6 Log-Pearson Type-III distribution, Ganga floods (1885-1971)

The flood frequency curves by the above four methods have been plotted on semi-log paper, (Fig. 15.5). It can be seen that the highest annual flood peak of 19136 cumec during a period of 87 years $\left(T = \frac{87 + 1}{1} = 88 - \text{yr}\right)$ has exceeded the 100-yr flood given by Gumbel's method and that computed by the new stochastic model based on the partial duration series. However, in this case, the stochastic method using annual flood data and Log-Pearson Type-III distribution give safe design values.

15.5 REGIONAL FLOOD-FREQUENCY ANALYSIS (RFFA)

A regional analysis becomes necessary when the available data on a catchment are too short for making a frequency analysis. Data for a long period available from neighbouring catchments are statistically tested for homogeneity. A group of stations satisfying the test are identified

which constitute a region. All the available data at various stations of this region are analysed to establish the frequency characteristics of the region. The mean annual flood (\bar{Q}) corresponding to $T = 2.33$ yr is used for non-dimensionalising the results. The variation of mean flood (\bar{Q}) with the drainage area (A), and the variation Q_T/\bar{Q} (called *growth factor*, GF) with the return period (T), are the basic plots prepared in such analysis.

RFFA for catchments of north Brahmaputra*

For estimation of floods of desired return period (T) for small and moderate size **gauged catchments** of north Brahmaputra river system, using the GEV-distribution, etc., the relationship is established as

$$Q_T = \bar{Q} \left[-11.67 + 12.48 \left\{ -\ln \left(1 - \frac{1}{T} \right) \right\}^{-0.025} \right] \quad \dots(15.30)$$

Flood-frequency estimates may be obtained by multiplying the mean annual flood peak (\bar{Q}) of the gauged catchment by the corresponding value of the growth factor, Fig. 15.7.

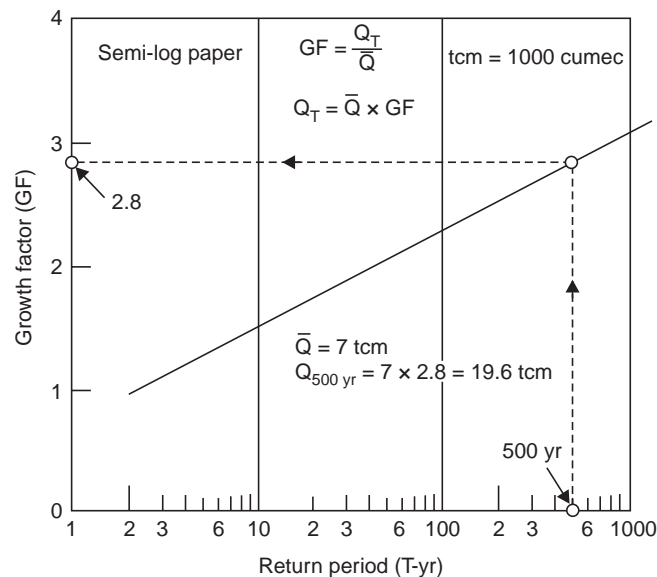

Fig. 15.7 Growth factor for gauged catchments for T-yr flood

For ungauged catchments, while there are no flow data and an estimation of a T -yr flood is required at a site for which an estimate of \bar{Q} is required.

For gauged catchments in the region of similar pertinent physiographic and climatic characteristics, in north Brahmaputra, a regional relationship has been developed in terms of catchment area (A (km^2)), for estimation of \bar{Q} for ungauged catchments as

$$\bar{Q} = 4.375 A^{0.72} \quad \dots(15.31)$$

*Rakesh kumar, et. al., "Development of Regional Flood Formulae using L-moments for Gauged and Ungauged Catchments of North Brahmaputra River System." Journ. of Inst. of Engrs. (India), Vol. 84, May 2003, P 57–63.

Substituting this in Eq. (15.30),

$$Q_T = A^{0.72} \left[-51.05 + 54.6 \left\{ -\ln \left(1 - \frac{1}{T} \right) \right\}^{-0.025} \right] \quad \dots(15.32)$$

which gives a T -yr flood (Q_T cumec) for ungauged catchments of area A km². This is graphically represented in Fig. 15.8.

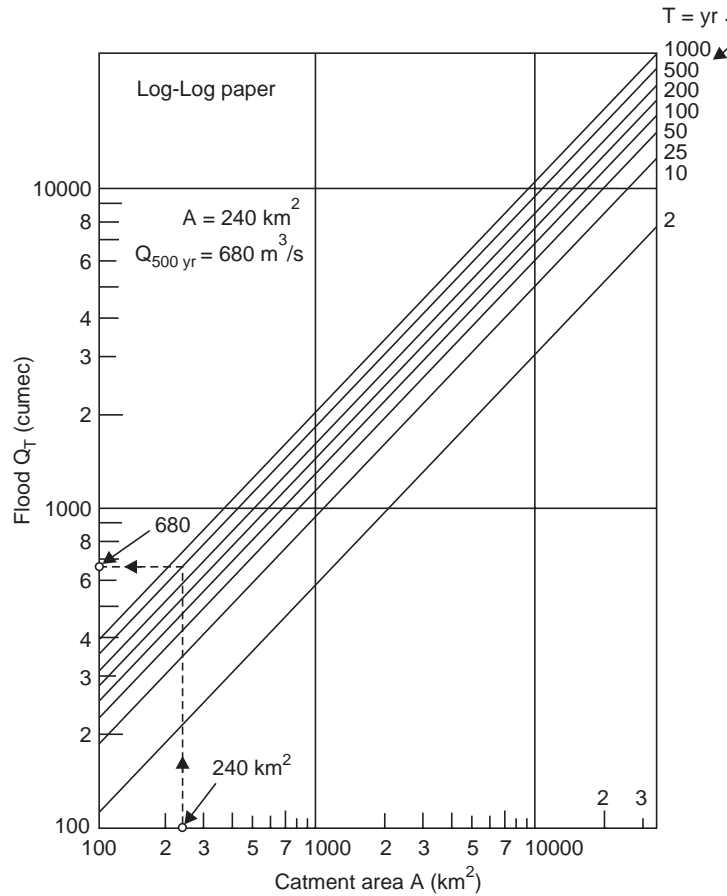

Fig. 15.8. Q_T for unguaged catchments of area A

In this RFFA screening of data is done by using the Discordancy measure (D_i), the L -moment homogeneity test, *i.e.*, Heterogeneity measure (H) and various distributions like GEV etc., for which regional parameters are estimated using L-moments approach.

PROBLEMS

- 1 For the annual floods of Lower Tapti river at Ukai, 30 years (1939-1968) given in Example 8.5, determine the 2, 10, 50, 100, 200 and 1000-yr flood magnitudes assuming Log-Pearson Type-III distribution. Draw the frequency line in Fig. 15.1 and compare with the other well-known frequency distributions.

- 2 Repeat problems in question No. 4, 5, 6, 7 and 18 at end of Chapter 8.
- 3 For the readings of Gauge height and Discharge for a stream, given in question no. 6 at the end of Chapter 6, obtain the Linear regression equation and find the discharge for the gauge readings of 1.6 m and 2.5 m.
- 4 For the annual floods of the river Ganga at Hardwar for 87 years (1885-1971) given in Example 15.1, determine the Foster's Type-III flood-frequency curve and plot on the semi-log paper in Fig. 15.5; compare it with the other well-known flood-frequency distributions.
- 5 Given below are the flood records for 15 years at Bhakra dam site on Sutlej river, determine by any frequency method:
- The 60-100-and 200-year floods
 - The flood magnitude having a 1% chance of occurrence in any one year
 - The recurrence interval of flood peaks of 6000 and 12000 cumec
- Comment on the limitations of flood-frequency analysis on such short records.

| <i>Year</i> | <i>Flood peak (cumec)</i> | <i>Year</i> | <i>Flood peak (cumec)</i> |
|-------------|---------------------------|-------------|---------------------------|
| 1937 | 3110 | 1945 | 2380 |
| 38 | 5800 | 46 | 3810 |
| 39 | 3090 | 47 | 7800 |
| 40 | 1723 | 48 | 4525 |
| 41 | 3630 | 49 | 3250 |
| 42 | 6600 | 50 | 4980 |
| 43 | 5260 | 1951 | 9200 |
| 44 | 2290 | | |

[Ans. *i.* 13.5, 15, 16.9 tcm; *ii* 1% = 100 yr = 15 tcm; *iii* $4\frac{1}{2}$ yr, 36 yr, not a true distribution series for extrapolation]

- 6 The annual flood peaks for 32 years (1948-1979) in the river Narmada at Garudeshwar are given below (tcm = 1000 cumec). Obtain the 500-yr and 1000-yr floods by (a) Gumbel's EV Type-I, (b) Log normal, and (c) Log-Pearson Type-III, methods.

| <i>Year</i> | <i>Flood peak (tcm)</i> | <i>Year</i> | <i>Flood peak (tcm)</i> |
|-------------|-------------------------|-------------|-------------------------|
| 1948 | 25.3 | 1964 | 19.5 |
| 1949 | 26.8 | 1965 | 15.2 |
| 1050 | 45.5 | 1966 | 13.0 |
| 1951 | 10.4 | 1967 | 22.6 |
| 1952 | 14.1 | 1968 | 58.0 |
| 1953 | 17.1 | 1969 | 31.2 |
| 1954 | 28.4 | 1970 | 69.4 |

(Contd.)...

| | | | |
|------|------|------|------|
| 1955 | 29.0 | 1971 | 20.0 |
| 1956 | 12.8 | 1972 | 48.0 |
| 1957 | 26.7 | 1973 | 61.2 |
| 1958 | 19.7 | 1974 | 27.3 |
| 1959 | 38.8 | 1975 | 33.7 |
| 1960 | 21.3 | 1976 | 19.5 |
| 1961 | 43.2 | 1977 | 22.7 |
| 1962 | 38.8 | 1978 | 34.2 |
| 1963 | 15.2 | 1979 | 38.1 |

[Ans. 103.4, 114; 120, 134; 127, 144 tcm
(\bar{x} = 29.6 tcm, σ = 14.86 tcm)
(MPF = 125 tcm)]

Chapter 16

MATHEMATICAL MODELS IN HYDROLOGY

16.1 TYPE OF MATHEMATICAL MODELS

The mathematical models in Hydrology can be classified as:

- (a) Stochastic models
- (b) Deterministic models

In the stochastic model, the chance of occurrence of the variable is considered thus introducing the concept of probability. A stochastic model is time-dependent while the probabilistic model is time-independent. For the time-independent probabilistic process, the sequence of occurrence of the variates involved in the process, is ignored and the chance of their occurrence is assumed to follow a definite probability distribution in which the variables are considered pure random. For the time-dependent stochastic process, the sequence of occurrence of the variates is observed and the variables may be either, pure random or non-pure random, but the probability distribution of the variables may or may not vary with time. For example, the flow duration curve procedure is probabilistic, whereas the flood routing through a reservoir is a stochastic procedure.

In the deterministic models, the chance of occurrence of the variables involved is ignored and the model is considered to follow a definite law of certainty but not any law of probability. For example, the mathematical formulation of the unit-hydrograph theory is a deterministic model.

Both the stochastic and deterministic models can be sub-classified as

- (i) Conceptual models
- (ii) Empirical models

In conceptual models, a mathematical function is conceived based on the consideration of the physical process, which when subjected to input variables, produces the output variables. For example, a conceptual catchment model of rainfall-runoff relationship can be described by

$$\phi[i(t)] = Q(t) \quad \dots(16.1)$$

where $i(t)$ = input, *i.e.*, rainfall

$Q(t)$ = output, *i.e.*, runoff

ϕ = system operator, *i.e.*, it represents the operation performed by the system to yield the output for the given input.

Empirical models are based on empirical relationships or formulae like Dickens, Ryves, Inglis, etc., where one composite coefficient takes into account all the variables affecting

possible flood peaks in a catchment; all the complex physical laws involved may not be considered here.

Examples of mathematical models. A conceptual or empirical model could be either deterministic or stochastic or a combination of these. For example, the model for predicting sediment transport is a combination of deterministic and stochastic components, which are often based on empirical relationships, whereas models based on regression analysis are stochastic conceptual models with a strong deterministic approach. Models concerning the propagation of flood wave and Nash model (cascade of linear reservoirs) are the examples of deterministic conceptual models, while models based on synthetic unit hydrograph are the examples of deterministic empirical models.

Optimisation of model and efficiency of model. A system is a set of elements organised to perform a set of designated function in order to achieve desired results. The project formulation of the system may be called *system design*. The objective of system design is to select the combination of system units or variables that maximises net benefits in accordance with the requirement of the design criteria. The design so achieved is known as the optimal design. The optimisation is subject to the requirements of the design criteria or constraints that are imposed. The constraints may be technical, budgetary, social or political and the benefits may be real or implied. When an objective is translated into a design criterion, it may be written in the form of a mathematical expression known as the *objective function*.

For mathematical model, the objective function which should be optimised is given by the equation

$$F = \sum_{i=1}^n (Q'_i - Q_i)^2 \quad \dots(16.2)$$

where Q'_i = actual observed value

Q_i = value predicted by model

The objective of the optimisation procedure is to obtain such sets of parameter values, which reduce the least squares objective function F to zero. For testing the significance and reliability of the optimised parameter values, statistical tests, predictive tests and sensitivity tests are often employed. Nash, et al (1970) have suggested the use of model efficiency (R^2) to evaluate the performance of the model.

$$R^2 = \frac{F_0 - F}{F_0} \quad \dots(16.3)$$

where

$$F_0 = \sum_{i=1}^n (Q_i - \bar{Q})^2 \quad \dots(16.3a)$$

$$\bar{Q} = \frac{\sum_{i=1}^n Q'_i}{n} = \text{mean of } n \text{ observed values}$$

R^2 is analogous to the coefficient of variation and is proportional to initial variation accounted by the model. The efficiency of a separable model part (r^2) can be judged by a change in the value of R^2 resulting by the insertion of that part or by the proportion of residual variance accounted for by its insertion.

$$r^2 = \frac{R_2^2 - R_1^2}{1 - R_1^2} = \frac{F_1 - F_2}{F_1} \quad \dots(16.4)$$

Predictive testing on a split sample basis is adopted in which the available data is divided into two parts; the first part is used to estimate the optimised parameter values and then, these are used to predict or reconstruct the second part of the data record. Sensitive tests generally test the effect of varying the optimised parameter value or the data on the objective function. This gives an idea of stability of the optimised parameter values or data error effects. Two studies on these lines are given below.

Excess rainfall-direct-runoff model—A model study was done at Roorkee (1976) using the data of a small catchment. Fig. 16.1, having a non-uniform-rainfall distribution. The values of n and K obtained by the method of moments in a Nash Model (1957)* were not able to

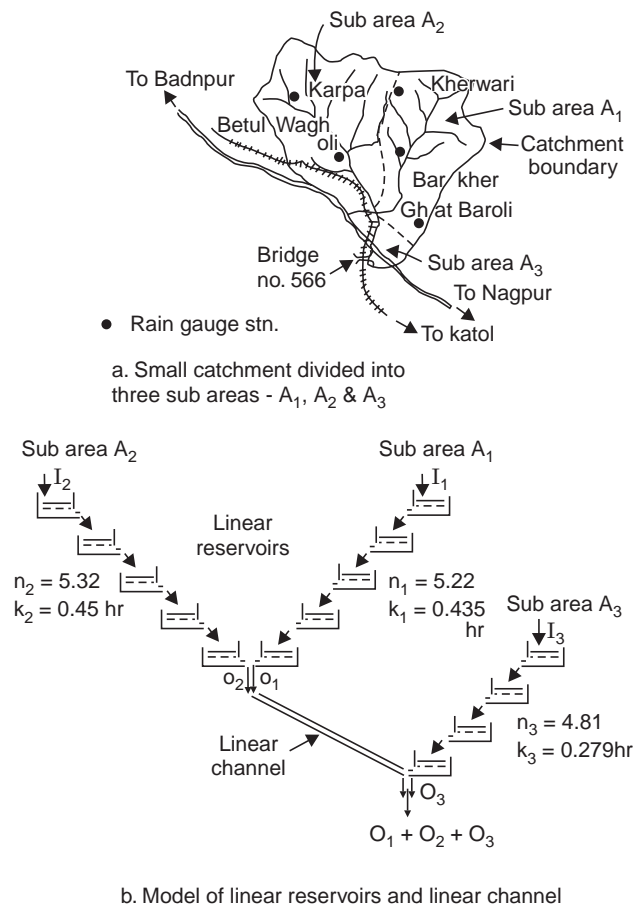

Fig. 16.1 Rainfall-runoff model (Roorkee, 1976)

simulate the peak of the observed hydrograph, though the values of the model efficiencies $R^2 = 83.7\%$ and 82.3% were obtained for the hydrograph used to derive the values of n and K , and the hydrograph of direct runoff, respectively. Then the catchment was divided into three sub-areas and each sub-area was modelled by means of cascade of linear reservoirs of equal storage coefficient. The values of n and K for each sub-area were obtained by using physiographic

*Nash (1957) used a series of n linear reservoirs of equal storage coefficient K , to obtain the instantaneous unit hydrograph assuming a lumped input and linear, time-invariant, deterministic system.

features of the catchment. The outflow from sub-areas A_1 and A_2 was combined together and then led through a linear channel having a translation constant T ; it was then combined with outflow of sub-area A_3 to obtain the values of direct runoff for the whole catchment. The model efficiency $R^2 = 82.3\%$ and 90% for the first and second hydrographs, respectively. However, further analysis had to be made for investing the effect of loss assumptions and non-uniform rainfall distribution, and possibly inclusion of translation concept by dividing the sub-areas by means of isochrones and representing them by combination of linear channel and linear reservoir in series.

Rainfall-runoff model based on retention concept. The retention concept of dividing the rainfall into runoff and non-runoff volumes is based on the physical processes of soil moisture retention. Model based on the retention concept was used by Seth (1972) for simulating the rainfall-runoff process of a small catchment. Its main components were those used to represent the retention capacity Y and evapotranspiration capacity E . Retention storage S was defined as that volume of water present in a natural watershed, which is not runoff storage. The maximum storage volume V of the retention storage of the catchment was subdivided into V_1 and V_2 for the upper and lower layer of soil, respectively. The moisture storage at any time, *i.e.*, retention storage in the upper and lower layers were S_1 and S_2 , respectively, and the ratio of S_1/V_1 and S_2/V_2 characterised the moisture status of the upper and lower layers, respectively

$$V = V_1 + V_2 \quad \dots(16.5)$$

$$S = S_1 + S_2 \quad \dots(16.5a)$$

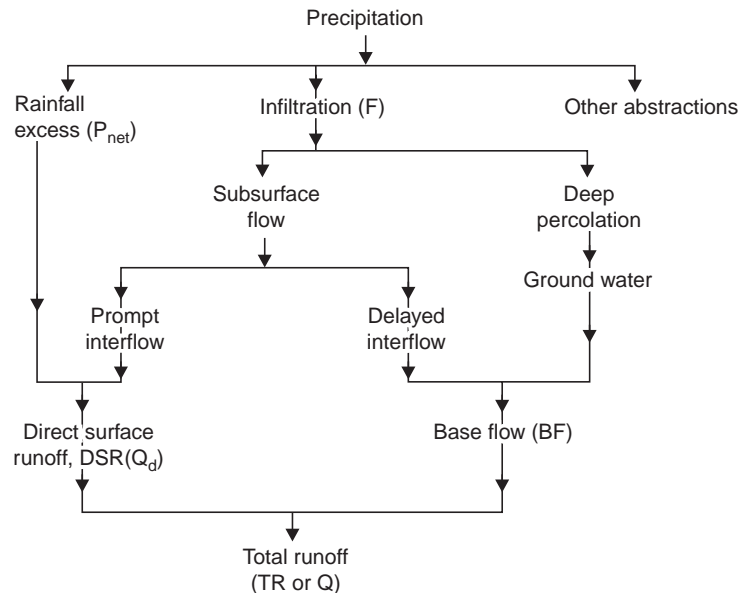

Fig. 16.2 Rainfall-runoff system

These components together with other components of the model gave a good performance when about a year's data of 2560 data pieces of 3 hourly values of rainfall, runoff and potential evaporation of Grendon Underwood Catchment of Institute of Hydrology (UK), were used. The values of $F = 14.07 \text{ mm}^2$ and $R^2 = 0.912$ obtained after optimisation run, compared quite favourably with those obtained by using the Stanford Model for the same data. The model values of soil moisture retained in soil gave almost a similar pattern as the observed soil

moisture. However, to take into account the full range of seasonal variations, it would be desirable to include a wide range of antecedent and storm period conditions existing perhaps over several years.

Rainfall-runoff system model. The rainfall to runoff transformation as a system is shown in Fig. 16.2.

A famous computer model is the Stanford Watershed Model (Crawford and Linsley, 1966). This model is refined progressively and is now a very comprehensive model based on water budgeting. By using hourly precipitation data and daily evapotranspiration as the main inputs, the model is programmed to produce hourly streamflow. Soil, vegetation, land use, etc., are all accounted for by a set of parameters, the values for which are progressively optimised by search technique. The flow diagram for the model is shown in Fig. 16.3 a which is, typical flow chart for a rainfall-runoff model of the explicit soil moisture accounting type, ESMA, redrawn from Linsley and Crawford (1974).

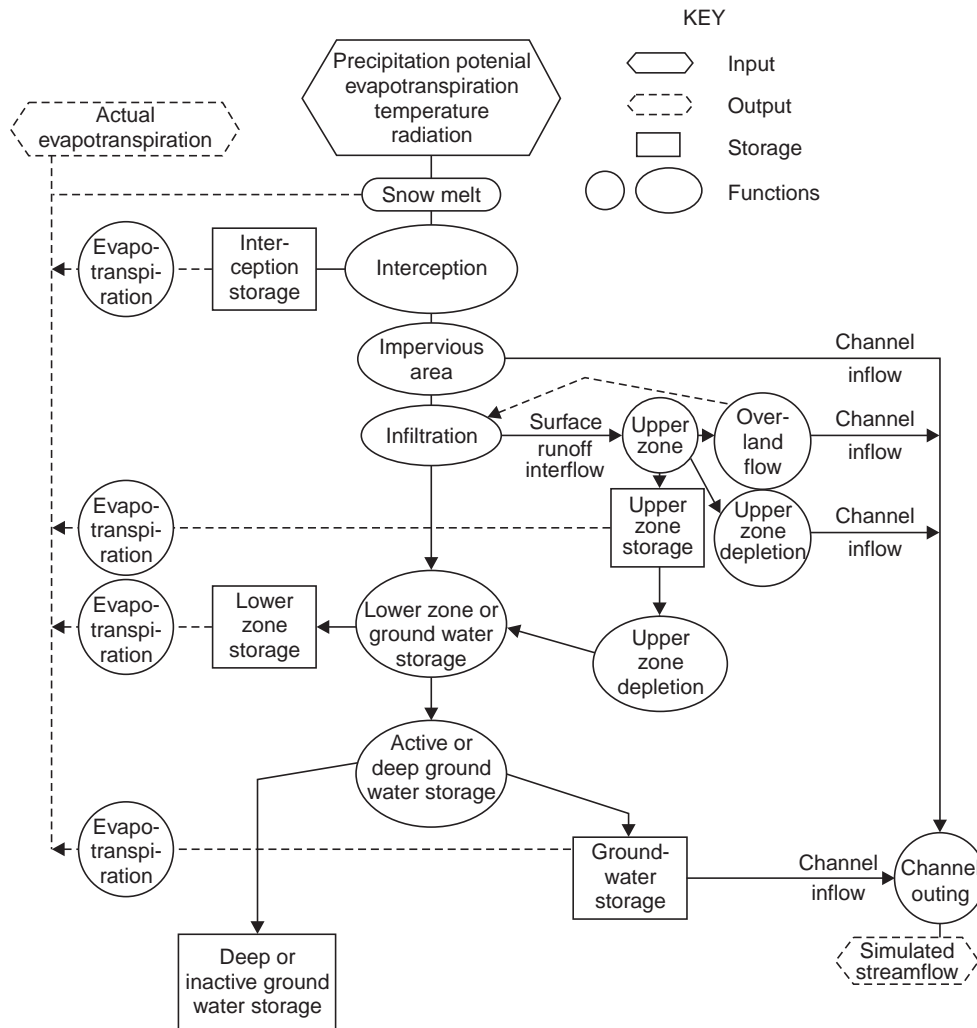

Fig. 16.3 Flow diagram of stanford watershed Model IV, ESMA (after Linsley and Crawford, 1974)

16.2 METHODS OF DETERMINING IUH

1. By the S-Curve Hydrograph

In Fig. 16.4, S_t is the S-curve ordinate at any time t (due to t_r -hr UG) and $S_{t'}$ is the ordinate at time t of the S-curve lagged by t'_r -hr, then the t'_r -hr UGO at time t can be expressed as

$$U(t'_r, t) = (S_t - S_{t'}) \frac{t_r}{t'_r} \quad \dots(16.6)$$

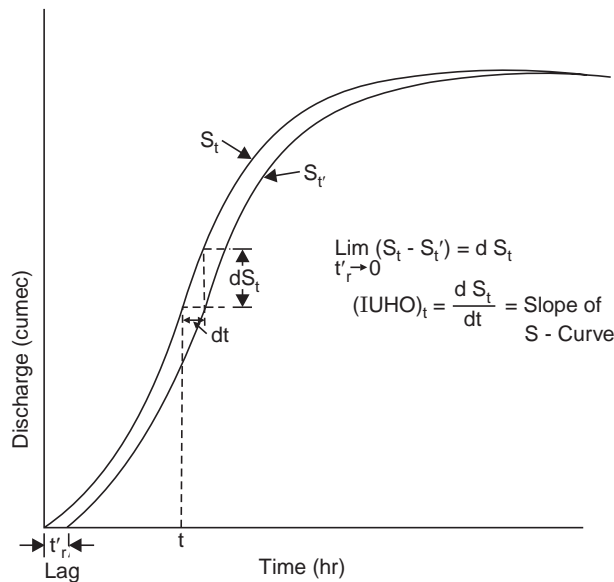

Fig. 16.4 IUH as S-curve derivative

As t'_r progressively diminishes, *i.e.*, $t'_r \rightarrow 0$, Eq. (16.6) reduces to the form (as can be seen from Fig. 16.4)

$$U(0, t) = \frac{dS_t}{dt} \quad \dots(16.7)$$

i.e., the ordinate of the IUH at any time t is simply given by the slope of the S-curve at time t ; in other words, the S-curve is an integral curve of the IUH. Since the S-curve derived from the observed rainfall-runoff data can not be too exact, the IUH derived from the S-curve is only approximate. The IUH, reflects all the catchment characteristics such as length, shape, slope, etc., independent of the duration of rainfall, thereby eliminating one variable in hydrograph analysis. Hence, it is useful for theoretical investigations on the rainfall-runoff relationships of drainage basins. The determination of the IUH is analytically more tedious than that of UG but it can be simplified by using electronic computers.

The t'_r - UGO can be obtained by dividing the IUH into t'_r -hr time intervals, the average of the ordinates at the beginning and end of each interval being plotted at the end of the interval (Fig. 16.5).

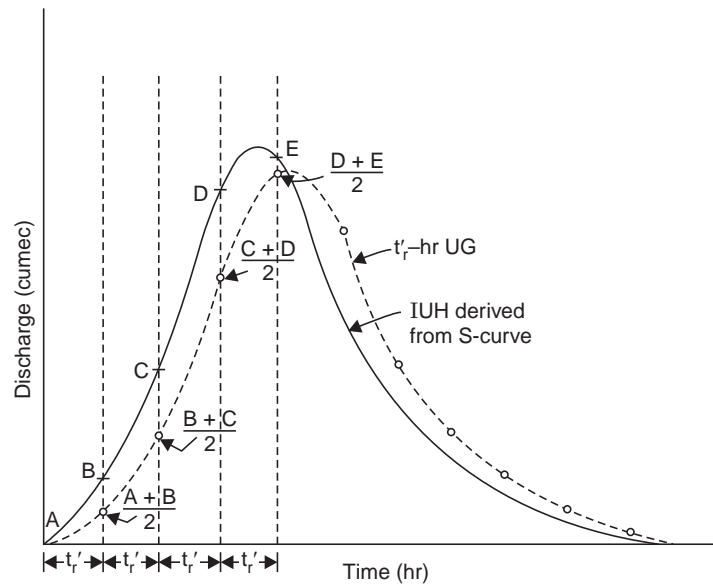

Fig. 16.5 t_r' -hr UG derived from IUH

2. By Using a Convolution Integral

By the principle of superposition in the linear-unit-hydrograph theory, when a net rainfall of function $i(t)$ of duration t_0 is applied, each infinitesimal element of P_{net} will produce a DRO, i.e., $Q(t)$ given by

$$Q(t) = \int_0^{t'} u(t - \tau) \cdot i(\tau) d\tau \quad \dots(16.8)$$

the upper limit t' given by

$$t' = t, \text{ when } t \leq t_0$$

$$t' = t_0, \text{ when } t \geq t_0$$

Eq. (16.8) is called the *convolution integral* (or *Duhamel integral*) in which $u(t - \tau)$ is a *kernel function*, $i(\tau)$ is the *input function*.

The shape of the IUH in Fig. 16.6 resembles a single peaked hydrograph. If the rainfall and runoff in the convolution integral are measured in the same units, the ordinates of the

IUH have the dimension $\frac{1}{\text{time}}$.

The properties of the IUH are given by

$$0 \leq u(t) \leq \text{a positive peak value, for } t > 0$$

$$u(t) = 0 \quad \text{for } t \leq 0$$

$$u(t) \rightarrow 0 \quad \text{for } t \rightarrow \infty \quad \dots(16.9)$$

$$\int_0^\infty u(t)dt = 1.0 \quad \text{and} \quad \int_0^\infty t u(t) dt = t_i$$

where t_i = lag time of IUH = time interval between the centroid of P_{net} and that of direct runoff. See next chapter 17 on IUH.

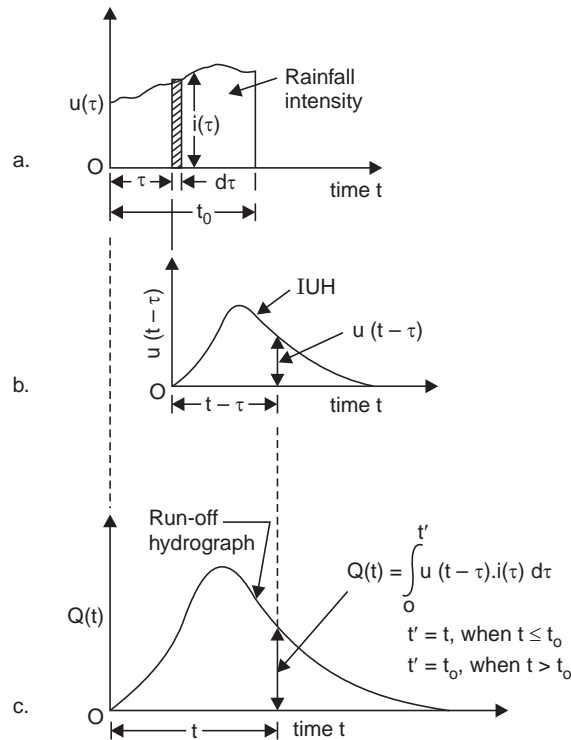

Fig. 16.6 Convolution of $i(\tau)$ and IUH

3. By Conceptual Models

Various conceptual models have been proposed to develop the IUH. They may be of physical analogy or mathematical simulation composed of linear reservoirs, linear channels, or time-area diagrams.

(a) Linear Reservoirs

A mathematical simulation of a drainage basin consisting of a series of linear reservoirs as proposed by J.E. Nash (1957) is discussed below:

A linear reservoir is a fictitious reservoir in which the storage is directly proportional to outflow, *i.e.*, $S = KO$.

From the principle of continuity

$$I - O = \frac{ds}{dt} \quad \dots(16.10)$$

From the condition $O = 0$ when $t = 0$, and that $S = KO$,

$$O = I(1 - e^{-t/k}) \quad \dots(16.11)$$

when $t = \infty$, $O = I$, *i.e.*, the outflow approaches an equilibrium condition and equals inflow. If the inflow terminates at time t_0 since outflow began, a similar derivation gives the outflow at time t in terms of out flow O_0 at t_0 , as

$$O_t = O_0 e^{-(t-t_0)/K} \quad \dots(16.12)$$

For an instantaneous inflow, which fills the reservoir storage S in time $t_0 = 0$, and since $S = KO$, $O_0 = \frac{S}{K}$, hence from Eq. (16.12)

$$O_i = \frac{S}{K} e^{-t/K} \quad \dots(16.13)$$

For a unit input or $S = 1$, the IUH of the linear reservoir is given by

$$u(t) = \frac{1}{K} e^{-t/K} \quad \dots(16.14)$$

This is represented by the hydrograph for the outflow from the first reservoir as shown in Fig. 16.7.

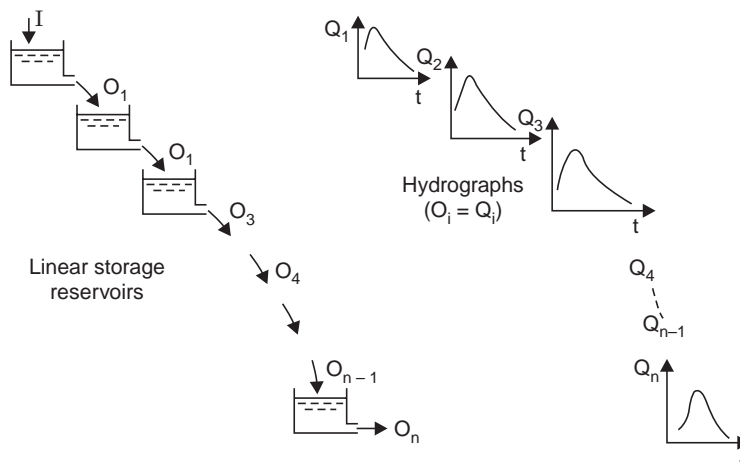

Fig. 16.7 Routing through linear reservoirs (Nash's Model)

(b) Simulation of Linear Channels

A linear channel is a fictitious channel in which the time T required to translate a discharge Q of any magnitude through a given channel reach of length x is constant. Hence, when an inflow hydrograph is routed through the channel, its shape will not change. At a given section, the relation between the water area A and the discharge Q is linear (assuming velocity to be constant), i.e.,

$$A = CQ$$

where $C = f(T)$ called 'translation coefficient' which is constant at a given section.

If a segment of inflow of duration Δt and volume S is routed through a linear channel, Fig. 16.8, the outflow is given by

$$O = S \delta(t, \Delta t) \quad \dots(16.15)$$

where
$$\delta(t, \Delta t) = \frac{1}{\Delta t} \quad \dots(16.16)$$

for $0 \leq \tau \leq \Delta t$ and $t = \tau + T$; it is zero otherwise, where τ is the time measured from the beginning of the segment. Eq. (16.16) is a 'pulse function'. When $\Delta t \rightarrow 0$, this equation becomes an 'impulse function' $\delta(t)$, known as a 'Dirac-delta function', which represents the IUH for the linear channel.

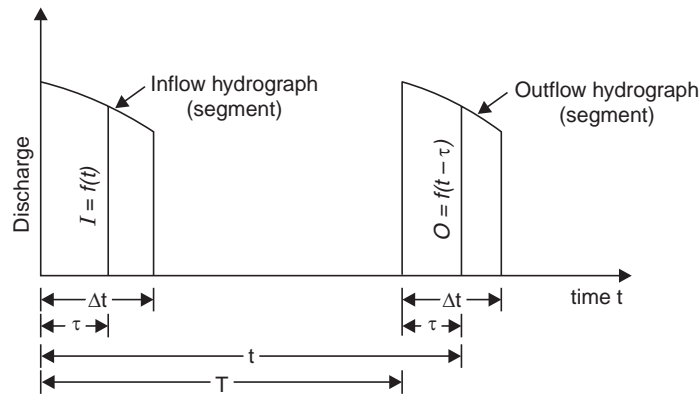

Fig. 16.8 Routing through linear channel

4. Routing Time–Area Curve of Basins

The principles of flood-routing can be used to derive unit hydrographs for a catchment where there are no complete records of rainfall-runoff.

The catchment may be divided into a series of sub-areas, each contributing inflow into drainage channels (which have storage) due to a flash storm. The IUH can be divided into two parts—the first representing inflow of the rain, and second, the gradual withdrawal from the catchment storage, the dividing line being the inflection point on the recession limb, Fig. 16.9.

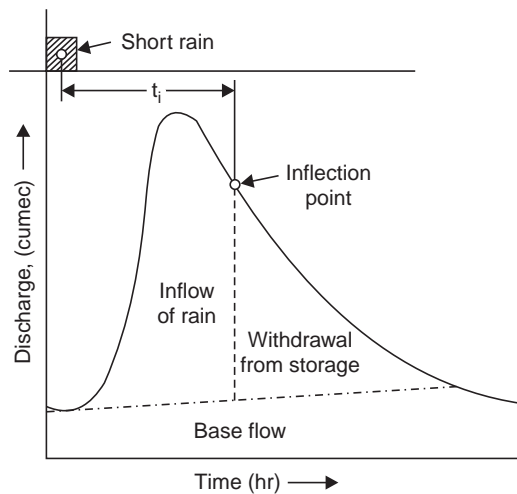

Fig. 16.9 Hydrograph from short rain (IUH)

Assuming that the catchment discharge (O) and the storage (S) are directly proportional

$$S = KO \tag{16.17}$$

where K = storage coefficient.

From the principle of continuity, if I = inflow resulting from the instantaneous rain

$$(I - O) \Delta t = \Delta S \tag{16.18}$$

or
$$\frac{I_1 + I_2}{2} t - \frac{O_1 + O_2}{2} t = S_2 - S_1 \quad \dots(16.19)$$

and
$$S_1 = KO_1, S_2 = KO_2$$

and hence,
$$O_2 = C_0 I_2 + C_1 I_1 + C_2 O_1 \quad \dots(16.20)$$

where
$$C_0 = \frac{0.5t}{K + 0.5t}, \quad C_1 = \frac{0.5t}{K + 0.5t}, \quad C_2 = \frac{K - 0.5t}{K + 0.5t} \quad \dots(16.20a)$$

which are same as Eqs. (9.12 a, b, c) with Muskingum approach, putting $x = 0$.
and when a sub-area distribution or time-area graph is used and $I_1 = I_2$, hence

$$O_2 = C' I + C_2 O_1 \quad \dots(16.21)$$

where
$$C' = \frac{t}{K + 0.5t}, \quad C' + C_2 = 1$$

From Eq. (16.18),
$$I - O = \frac{dS}{dt}$$

$$\therefore S = KO, \quad \frac{dS}{dt} = K \frac{dO}{dt}$$

$$\therefore K \frac{dO}{dt} = I - O$$

Using the condition $O = 0$, when $t = 0$, the equation can be solved as

$$O = I(1 - \exp(-t/K)) \quad \dots(16.22)$$

Since the inflow ceases at the inflexion point at time t_i , the outflow at time t (in terms of the outflow O_{ti} at t_i) is given by

$$Q_t = O_{ti} \exp\left(-\frac{t-t_i}{K}\right)$$

Storage coefficient K can be determined from an observed hydrograph by noting two values of O , unit time apart at the point of inflection (Fig. 16.10).

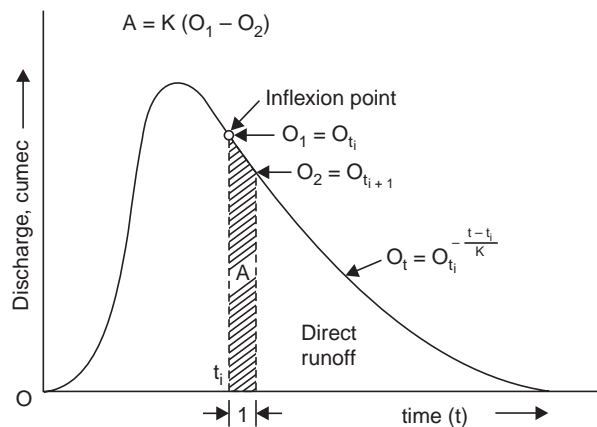

Fig. 16.10 Determination of storage coefficient

$$O_1 = O_{t_i} \text{ and } O_2 = O_{t_i} \exp\left(-\frac{t-t_i}{K}\right)$$

the shaded area $A = \int_{t_i}^{t_i+1} O_{ti} \exp\left(-\frac{t-t_i}{K}\right) dt = -KO_{ti} \exp\left(-\frac{t-t_i}{K}\right) \Big|_0^1 = KO_{ti} - O_{ti} \exp\left(-\frac{1}{K}\right)$
 $\therefore A = K(O_1 - O_2)$... (16.23)

Another observation that is to be made is the catchment lag (t_i), i.e., the maximum travel time through the catchment. This may be taken as the time from the mass centre of the causative rain (flash storm or short rainburst to minimise error) to the inflection point on the recession limb.

The catchment is subdivided into isochrone such that the rain falling in any sub-area has the same time of travel to the outflow point O , (Fig. 16.11). The time-area graph (I) now has instantaneous unit rain applied to it and is routed through to obtain the outflow (O), Eq. (16.21). This outflow represents the IUH for the catchment and may be converted, if required to a t_r -hr unit hydrograph.

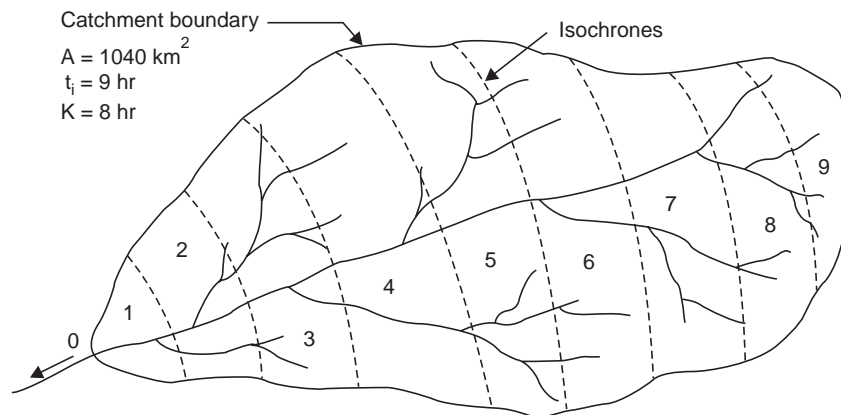

Fig. 16.11 Catchment divided into isochrones

This method is simple and the design rain can be applied directly to the time-area graph, with areal variation and with any desired intensity.

An estimate of K can also be had from data on the recession limbs of the basin hydrographs.

Example 16.1 A catchment of area 1040 km^2 is divided into 9-hourly divisions by isochrones (lines of equal travel time) in Fig. 16.11. From the observation of a hydrograph due to a short rain on the catchment, $t_i = 9 \text{ hr}$ and $K = 8 \text{ hr}$. Derive: (a) the IUH for the catchment. (b) a 3-hr UG.

Solution (i) It will be assumed that the catchment is divided into sub-areas such that all surface runoff from each of these areas will arrive during a 1-hr period at the gauging point. The areas are measured by planimetering each of the hourly areas as:

| | | | | | | | | | |
|-------------------------|----|-----|-----|-----|-----|-----|-----|----|----|
| Hour: | 1 | 2 | 3 | 4 | 5 | 6 | 7 | 8 | 9 |
| Area (km^2): | 40 | 100 | 150 | 180 | 160 | 155 | 140 | 80 | 35 |

(ii) The time-area graph (in full lines) and the distribution graph of runoff (in dotted lines) are drawn as shown in Fig. 16.12. The dotted lines depict the non-uniform areal distribution of rain.

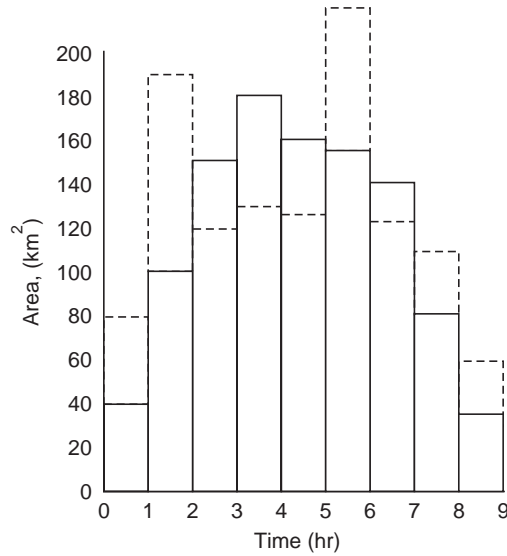

Fig. 16.12 Time-area graph for catchment

Table 16.1 IUH by routing and derivation of 3-hr UG (Example 16.1)

| Time (hr) | Time-area diagram Area (km ²) | 0.1177 I = 2.78 × 0.1177 × col (2) (cumec) | 0.882 × col (5) previous (cumec) | O ₂ = IUH = col (3) + col (4) (cumec) | 3-hr UGO (cumec) |
|-----------|---|--|----------------------------------|--|------------------|
| 1 | 2 | 3 | 4 | 5 | 6 |
| 0 | 0 | 0 | 0 | 0 | 0 |
| 1 | 40 | 13.1 | 0 | 13.10 | |
| 2 | 100 | 32.7 | 11.54 | 44.24 | |
| 3 | 150 | 49.1 | 39.00 | 88.10 | 44.00 |
| 4 | 180 | 58.9 | 77.70 | 136.60 | |
| 5 | 160 | 52.3 | 120.40 | 172.70 | |
| 6 | 155 | 50.7 | 152.00 | 202.70 | 145.40 |
| 7 | 140 | 45.8 | 179.00 | 224.80 | |
| 8 | 80 | 26.2 | 197.00 | 223.20 | |
| 9 | 35 | 11.4 | 196.50 | 208.00 | 205.30 |
| 10 | 0 | 0 | 184.50 | 184.50 | |
| 11 | 0 | 0 | 163.70 | 163.70 | |
| 12 | 0 | 0 | 145.00 | 145.00 | 176.50 |
| 13 | 0 | 0 | 128.60 | 128.60 | |
| 14 | 0 | 0 | 114.00 | 114.00 | |
| 15 | 0 | 0 | 101.00 | 101.00 | 123.00 |

Plot col (1) vs. col (5) to get the IUH, and col (1) vs. col (6) to get the 3-hr UGO, as shown in Fig. 16.13.

(iii) From Eq. (16. 21), $O_2 = C'I + C_2O_1$

$$C' = \frac{t}{K + 0.5t} = \frac{1}{8 + 0.5 \times 1} = \frac{1}{8.5} = 0.1177$$

$$C_2 = \frac{K - 0.5t}{K + 0.5t} = \frac{8 - 0.5 \times 1}{8 + 0.5 \times 1} = \frac{7.5}{8.5} = 0.882, \quad \text{Check: } C' + C_2 = 1$$

Hence, the routing equation becomes

$$O_2 = 0.1177 I + 0.882 O_1$$

O_2 vs. time gives the required synthetic IUH from which the 3-hr UGO are obtained as computed in Table 16.1. The conversion constant for Col (3) is computed as

$$1\text{-cm rain on } 1 \text{ km}^2 \text{ in } 1 \text{ hr} = \frac{10^6 \times 10^{-2}}{3600} = 2.78 \text{ m}^3/\text{s}$$

The 3-hr UGO is obtained by averaging the pair of IUH ordinates at 3-hr intervals and writing at the end of the intervals.

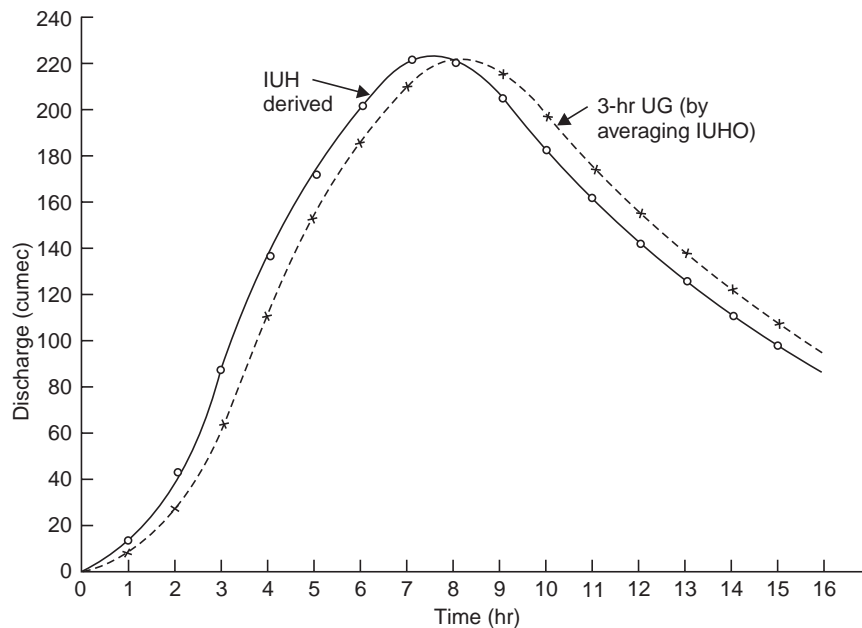

Fig. 16.13 IUH derived and 3-hr UG (Example 16.1)

16.3 SYNTHETIC STREAM FLOW

The probability of occurrence of floods or droughts are more severe than that observed from the available stream flow records has to be known. On the assumption that the streamflow is essentially a random variable, it is possible to develop a synthetic flow record by statistical methods.

It has been found that high flows are likely to follow high flows and the low flows follow low flows, *i.e.*, any event is dependent on the preceding event. This persistence is measured by

a serial lag coefficient. The lag interval may be one or several time units. A simple one lag Markov generating equation for annual flows Q is

$$Q_i = \bar{Q} + r_i(Q_{i-1} - \bar{Q}) + \varepsilon_i \sigma \sqrt{1 - r_i^2} \quad \dots(16.24)$$

where σ = standard deviation of Q

\bar{Q} = mean of Q

i = 1 year to n year (flows in series)

r_i = lag-1 Markov coefficient, which is a portion of the departure from the previous flow from the mean.

The Eq. (16.25) yields a normal synthetic flow that preserves the maximum variance, and first-order-correlation coefficient of the observed record. Statistical streamflow models are assumed stationary, *i.e.*, the mean and variance of the observations (time series) are unchanged with time.

Thomas and Fiering (1962) used the Markov Chain model for generating monthly flows (by serial correlation of monthly flows) by using the following recursion equation.

$$q_{i+1} = \bar{q}_{j+1} + b_j(q_i - \bar{q}_j) + \varepsilon_i \sigma_{j+1} \sqrt{1 - r_j^2} \quad \dots(16.25)$$

where q_i, q_{i+1} = discharges in the i and $i + 1$ months, respectively

\bar{q}_j, \bar{q}_{j+1} = mean monthly discharges in the j and $j + 1$ months of the annual cycle

b_j = regression coefficient for estimating the discharge in the $j + 1$ month from that in the j month

ε_i = a random normal deviate at time i with a zero mean and unit variance.

σ_{j+1} = standard deviation of discharges in the $j + 1$ month

r_j = correlation coefficient between the discharges in the j and $j + 1$ months.

The Eq. (16.25) is called 'Lag-one single period Markov Chain Model, where the period may be day, month or year.

To reflect different seasonal or monthly means, the multi-period Markov model is used, which requires a double indexing subscript as (using Q for annual flows)

$$Q_{i,j} = \bar{Q}_j + b_j(Q_{i-1,j-1} - \bar{Q}_{j-1}) + \varepsilon_i \sigma_j \sqrt{1 - r_j^2} \quad \dots(16.26)$$

where $b_j = r_j \left(\frac{\sigma_j}{\sigma_{j-1}} \right)$, since $\bar{Q}_{j+1} \neq \bar{Q}_j$... (16.26a)

j = number of seasonal periods or months in the year and other terms have been defined in Eq. (16.25) in which $q = Q$ for annual flows.

This model has been used extensively in stream flow analysis. The single-and multi-period Markov generation procedures sometimes result in negative flows. These flows must be retained for generating the next flows in sequence and then they may be discarded.

The procedure assumes that the discharges (or their transform) are normally distributed. A synthetic flow record generated like this can be of any desired length and may well include flow sequences more critical than any in the available observed record. Stochastic analysis can be used to generate a number of synthetic-flow traces of length equal to the expected useful life of project under study.

Stochastic methods may be employed to generate a synthetic record of rainfall, which could be transformed to streamflow (by doing a particular operation), which the available streamflow records are found too short for a stochastic generation. The Markov process for generating a sequence of rainfall data is given by the relation

$$P(X_{t+1} = j | X_t = i) \quad \dots(16.26b)$$

which expresses the conditional probability of ‘transitioning’ from the state i at period t to state j at $(t + 1)$.

Matalas (1967) used a simple matrix representation of the problem, similar to the Markovian model, as

$$X_{t+1} = AX_t + B\varepsilon_{t+1} \quad \dots(16.27)$$

where $X_t = n \times 1$ matrix representing the non-autocorrelated standardised flow at n stations at time t

X_{t+1} = a similar matrix as above at time $(t + 1)$

$\varepsilon_{t+1} = n \times 1$ matrix of non-autocorrelated random numbers with zero mean and unit variance

$A, B = n \times n$ matrices, the elements being so chosen as to preserve time mean \bar{q} , variance σ^2 , lag 1-serial correlation coefficient r and the cross correlation coefficients r_{nm} between all the data elements being modelled.

Data generated by models can be used to design reservoir capacity by using low-flow-frequency mass diagram and other techniques. Several hundred years of records are generated to obtain an adequate number of high-and low-flow sequences.

16.4 FLOW AT UNGAUGED SITES BY MULTIPLE REGRESSION

At sites where streamflow records are not available, the flow can be estimated by a multiple-regression technique using the drainage basin and climatic characteristics as independent variables. The regression constant and coefficient are calculated using streamflow data from gauged streams. By expressing the variables in common logarithms, the equation can be transformed to the linear form as

$$\log Q = a + b_1 \log x_1 + b_2 \log x_2 + \dots + b_n \log x_n \quad \dots(16.28)$$

where Q = annual or monthly peak flow or runoff volume with any assigned probability and duration; the dependent variable, cumec.

a = regression constant

x = an independent variable characteristic of a drainage basin or its climatic factor

b = the regression coefficient for x

Twenty or more sets of data are required to obtain reliable values of the regression constant and coefficients by solving Eq. (16.28), which is usually done by the use of a computer.

16.5 RESERVOIR MASS CURVE

A mass curve (or Rippl diagram, 1882) is a cumulative plotting of net reservoir inflow (Fig. 16.14), and is expressed as

$$V(t) = \int_0^t Q(t)dt \quad \dots(16.29)$$

where $V(t)$ = volume of runoff
 $Q(t)$ = reservoir inflow
 both as functions of time

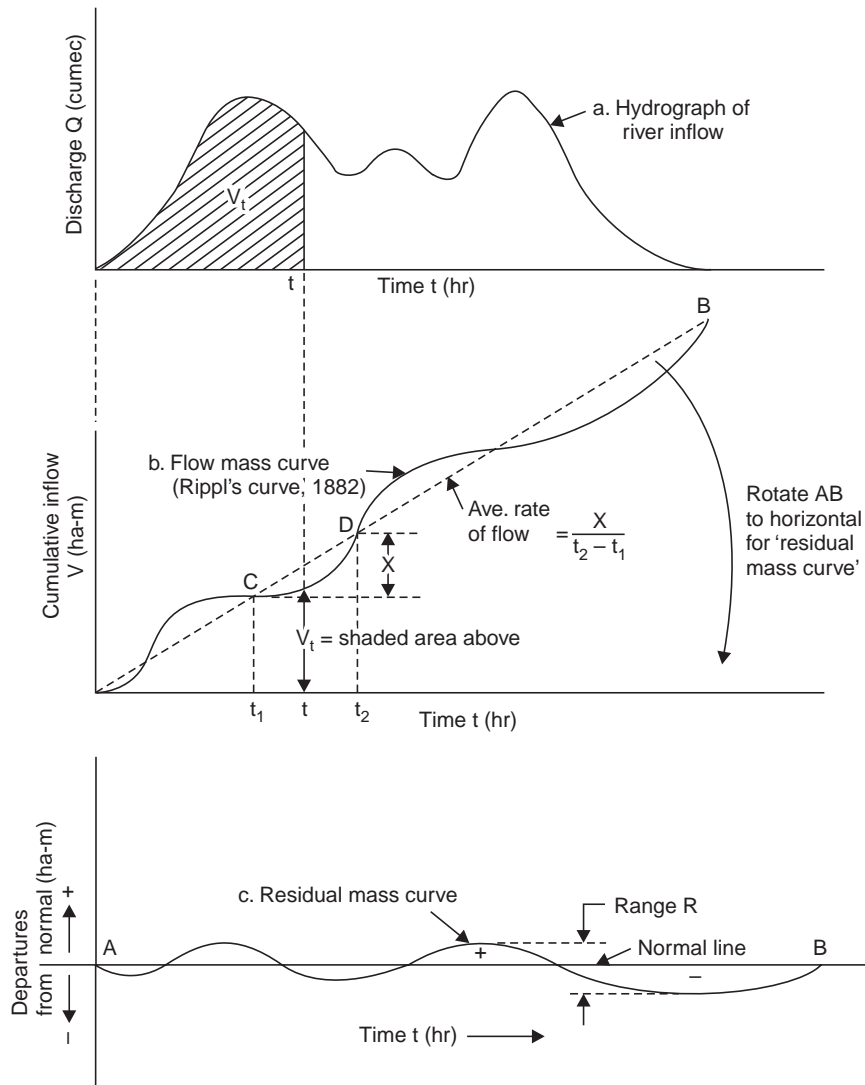

Fig. 16.14 Flow and residual mass curves

The instantaneous rate of flow at any point on the mass curve is given by the slope of the tangent at the point, *i.e.*

$$Q(t) = \frac{dV(t)}{dt} \quad \dots(16.29a)$$

As already discussed, the mass curve has many useful applications in the design of a storage reservoir, such as determination of reservoir capacity, operations procedure and flood routing.

16.6 RESIDUAL MASS CURVE

Instead of plotting a mass curve, the departure of the mass curve from the normal (*AB*) may be plotted against time. In other words, the mass curve is plotted about a horizontal axis obtained by rotating the average slope line *AB* of the mass curve, to the horizontal (Fig. 16.14 (c)). Such a plot is called a ‘residual mass curve’. This method of plotting saves the additional space needed for plotting a continuously rising mass curve and to accentuate more clearly the crests and troughs of the cumulative flow records.

The difference between the maximum and minimum values of a residual mass curve for a given period ‘*n*’ is known as the ‘range’ for the period ‘*n*’. If *R* is the range of a period of *n* years of annual-runoff record-whose sample standard deviation is σ , then according to Hurst (1951, 1956) and Klemes (1974)

$$R = \sigma \left(\frac{n}{2} \right)^k \quad \dots(16.30)$$

where *k* varies from 0.5 to 1 with an average value of 0.73. Here *R* will be the required storage if a steady discharge equal to the mean over a period of *n* years is to be produced. Theoretically, it can be shown that if the runoff record is a normally distributed random time series, then

$$R = 1.25 \sigma_p \sqrt{n} \quad \dots(16.31)$$

where σ_p = the population standard deviation.

16.7 SELECTION OF RESERVOIR CAPACITY

The determination of the required capacity of a storage reservoir is usually called an ‘operation study’ using a long-synthetic record. An operation study may be performed with annual, monthly, or daily time intervals; monthly data are most commonly used.

When the analysis involves lengthy synthetic data, a computer is used and a sequent-peak algorithm is commonly used. Values of the cumulative sum of inflow minus withdrawals taking into account the precipitation, evaporation, seepage, water rights of the downstream users, etc., are calculated, (Fig. 16.15). The first peak and the next following peak, which is greater than the first peak, *i.e.*, the sequent, peak, are identified.

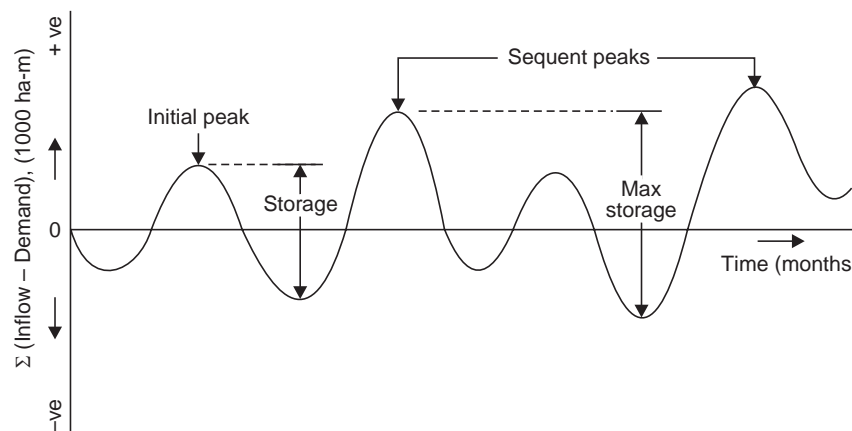

Fig. 16.15 Sequent-peak algorithm

The maximum difference between this sequent peak and the lowest trough during the period under study is taken as the required storage capacity of the reservoir.

Example 16.2 The mean monthly flow data for a proposed reservoir site are given below:

| | | | | | | |
|---------------------------|-------|------|-------|-------|------|------|
| Month | Jan. | Feb. | Mar. | April | May | June |
| Mean monthly flow (cumec) | 6 | 3 | 1 | 2 | 7 | 1 |
| Month | July. | Aug. | Sept. | Oct. | Nov. | Dec. |
| Mean monthly flow (cumec) | 27 | 29 | 30 | 27 | 31 | 15 |

Determine the average discharge that can be expected throughout the year. Draw the residual mass curve and obtain an expression for the range as developed by Hurst on the basis of the monthly flow data.

Solution

| Month | Mean monthly flow, x (cumec) | Monthly flow volume (ha-m) | Cumulative monthly inflow (ha-m) | Cumulative mean flow throughout the year (ha-m) | Residual mass curve (ha-m) |
|----------|--------------------------------|----------------------------|----------------------------------|---|----------------------------|
| 1 | 2 | 3 | 4 | 5 | 6 |
| Jan | 6 | 1575 | 1575 | 3931 | -2356 |
| Feb | 3 | 790 | 2365 | 7862 | -5497 |
| Mar | 1 | 262 | 2627 | 11793 | -9166 |
| April | 2 | 525 | 3152 | 15725 | -12573 |
| May | 7 | 1840 | 4992 | 19656 | -14664 |
| June | 1 | 262 | 5254 | 23587 | -18333 |
| July | 27 | 7100 | 12354 | 27518 | -15164 |
| Aug | 29 | 7750 | 20104 | 31450 | -11346 |
| Spet | 30 | 7880 | 27984 | 35381 | -7397 |
| Oct | 27 | 7100 | 35084 | 39312 | -4228 |
| Nov | 31 | 8150 | 43234 | 43243 | -0009 |
| Dec | 15 | 3940 | 47174 | 47174 | 0 |
| $n = 12$ | 179 | 47174 | | | |

$$\bar{x} = \frac{179}{12} = 15 \text{ cumec} \quad \text{Mean flow (per month) throughout the year} = \frac{47174}{12} = 3931.2 \text{ ha-m}$$

The average discharge that can be expected throughout the year

$$Q = \frac{47174 \times 10^4 \text{ m}^3}{365 \times 86400 \text{ S}} = 15 \text{ cumec} = \bar{x}$$

The residual mass curve is plotted in Fig. 16.16 and the range, $R = 18333$ ha-m, which is the storage capacity of the reservoir to maintain the mean flow of 15 cumec throughout the year.

| | | | | | | | | | | | | |
|-----------------|----|-----|-----|-----|----|-----|----|----|----|----|----|----|
| x : | 6 | 3 | 1 | 2 | 7 | 1 | 27 | 29 | 30 | 27 | 31 | 15 |
| $x - \bar{x}$: | -9 | -12 | -14 | -13 | -8 | -14 | 12 | 14 | 15 | 12 | 16 | 0 |

$(x - \bar{x})^2$: 81 144 196 169 64 196 144 196 225 144 256 0
 $\Sigma (x - \bar{x})^2 = 1815$

$$\sigma = \sqrt{\frac{\Sigma(x - \bar{x})^2}{n - 1}} = \sqrt{\frac{1815}{12 - 1}} = 12.84 \text{ cumec}$$

Let $R = \sigma \left(\frac{n}{2}\right)^k$

$$18333 \times 10^4 = 12.84 (30.4 \times 24 \times 60 \times 60) \left(\frac{12}{2}\right)^k$$

$$6^k = \frac{18333 \times 10^4}{3370 \times 10^4} = 5.44$$

$\therefore k = 0.945$

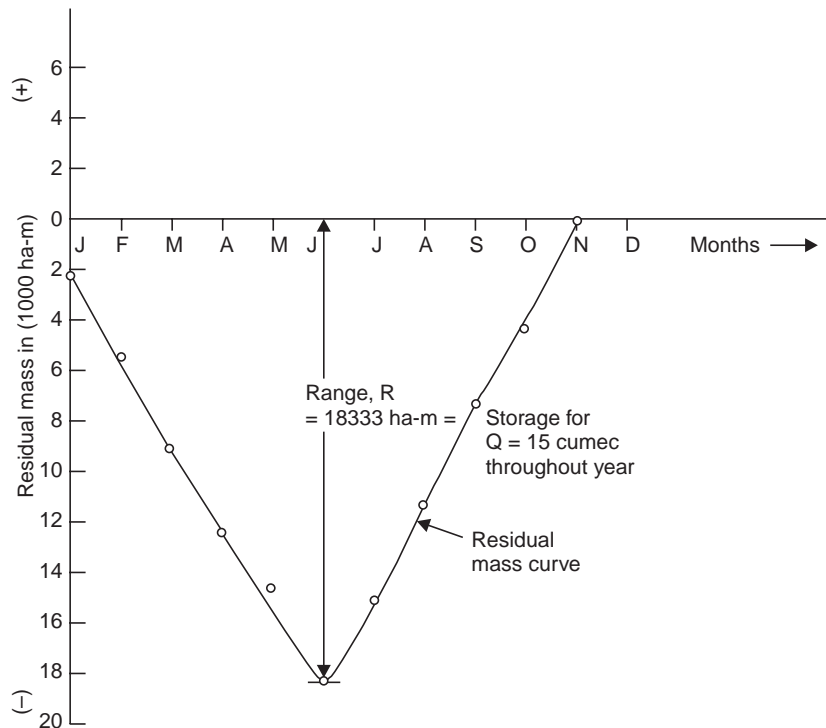

Fig. 16.16 Residual mass curve (Example 16.2)

Thus, the expression for range (on the basis of 12 months data) is

$$R = \sigma \left(\frac{n}{2}\right)^{0.945} \quad \dots(16.32)$$

Usually k varies from 0.5 to 1.0, the average value being 0.73. Usually, a number of years of observation are required.

Example 16.3 Given in Table 16.2 (Col. 1, 2, 3, 5 and 6) are the monthly inflows during low-water period at the site of a proposed dam, the corresponding monthly precipitation and pan

evaporation at a nearby station, and the estimated monthly demand for water. Prior water rights downstream require a special release of 6 cumec or the natural inflow, whichever is less. Assuming that only 24% of the rainfall on the land area to be flooded by the proposed reservoir has reached the stream in the past, reservoir area as 6000 ha on an average, and a pan coefficient of 0.7, construct the sequent peak algorithm and determine the required storage capacity of the reservoir.

Solution Since 24% of the rainfall (P) is runoff, which is already included in the monthly inflows into the reservoir, only $100 - 24 = 76\%$ of the rainfall on the reservoir area is to be included. Reservoir evaporation = $0.7 \times$ pan evaporation (E_p). ($0.76P - 0.7 E_p$) values have to be multiplied by the average reservoir area at the beginning and end of each month.

The monthly change in storage and cumulative storage (at the end of each month) are worked out in Table 16.2 and the sequent peak algorithm is drawn as shown in Fig. 16.17 and the required storage capacity of the Reservoir (difference between the initial peak and the lowest trough in the interval) is 13045 ha-m, which is also indicated in the col. (10) of Table 16.2. Actually this process has to be done for 4-5 consecutive years and the difference between **the highest peak and the succeeding lowest trough** gives the required storage capacity to meet the specified demand. The required storage capacity is also equal to the sum of the negative quantities (Σ Deficit) in Col (8) of Table 16.2, which is less than the sum of the positive quantities (Σ Surplus) col (8), thus ensuring the filler of the reservoir during monsoons.

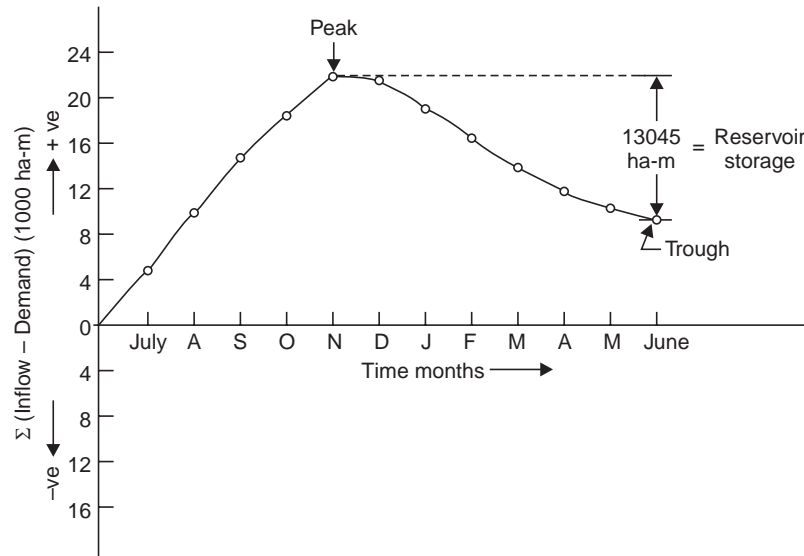

Fig. 16.17 Sequent-peak Algorithm (Example 16.3)

16.8 FLOOD FORECASTING

With the operation of flood forecasting centres in India since 1969, heavy loss of life and suffering of people are greatly minimised due to advance warning. In the country, there are 8 forecasting centres with 25 sub-centres and more than 200 observation sites have been equipped with wireless. In addition to this, rainfall data from 30 ordinary rain gauge stations and 50 self-recording rain gauge stations are also collected to supplement the gauge and discharge data.

Table 16.2 Operation study for a storage reservoir (Example 16.3)

| Month | Mean monthly flow, Q (cumec) | Monthly flow volume (ha-m) | Precipitation, P (mm) | Pan Evaporation, E_p (mm) | Demand (ha-m) | D/s Release (ha-m) | Change in storage, Δs (ha-m) $= (3) + (4) - (5) - (6) - (7)$ | Cumulative storage, $\Sigma \Delta s$ (ha-m) | Reservoir capacity (ha-m) |
|-------|------------------------------|----------------------------|-----------------------|-----------------------------|---------------|--------------------|---|--|---|
| 1 | 2 | 3 | 4 | 5 | 6 | 7 | 8 | 9 | 10 |
| July | 27 | 6998† | 135 | 155 | 650 | 1555† | +4758* | 4758 | Reservoir capacity = 13045 ha-m † = 13045 ha-m ‡ Deficit = 13045 ha-m † Surplus = 22051 ha-m |
| Aug. | 29 | 7257 | 175 | 75 | 975 | 1555 | +5210 | 9968 | |
| Sept. | 30 | 7776 | 140 | 80 | 1200 | 1555 | +5071 | 15039 | |
| Oct. | 27 | 6998 | 25 | 125 | 1750 | 1555 | +3282 | 18321 | |
| Nov. | 31 | 8035 | 5 | 65 | 2500 | 1555 | +3730 | 22051 | |
| Dec. | 15 | 3888 | 0 | 40 | 2500 | 1555 | -335 | 21716 | |
| Jan. | 6 | 1555 | 0 | 50 | 2500 | 1555 | -2710 | 19006 | |
| Feb. | 3 | 777 | 0 | 80 | 2400 | 777 | -2736 | 16270 | |
| March | 1 | 259 | 0 | 100 | 2250 | 259 | -2670 | 13600 | |
| April | 2 | 518 | 20 | 130 | 1500 | 518 | -1955 | 11645 | |
| May | 7 | 1814 | 45 | 195 | 1250 | 1555 | -1605 | 10040 | |
| June | 1 | 259 | 100 | 200 | 650 | 259 | -1034 | 9006 | 13045 |

1. †27 cumec × 30 days = 27(30 × 86400)/10⁴ = 6998 ha-m

2. ‡56 cumec × 30 days = 6 (30 × 86400)/10⁴ = 1555 ha-m

3. *6998 + $\frac{135 \times 0.75 - 155 \times 0.7}{1000} \times 6000 - 650 - 1555 = +4758$ ha-m

4. Reservoir capacity = sum of negative quantities in col. (8).

Factors governing forecasting can be divided into two groups—initial and final. The initial factors govern conditions existing at the time when the forecast is made and can be estimated on the basis of current hydrometeorological observations. The final factors include the future weather conditions and has to be taken into account in hydrological forecasts, if an accurate weather forecast is available. In practice, short-term forecasts of weather elements are being used in compilation of hydrological forecasts and warnings.

The elements of forecasts include forecast of crest stages, discharge and time of occurrence, etc. In some cases, the other basic water regime elements to be known are:

- (i) volume of runoff in respect of various periods of time
- (ii) flow distribution
- (iii) MWL in reservoir and the data of occurrence

The data required for making an accurate forecast are:

- (a) stage and discharge of upstream base station
- (b) stage and discharge of forecasting station
- (c) change in stage and discharge of these stations
- (d) stage and discharge of any tributary joining the main stream between the base station and forecasting site
- (e) the intensity, duration and distribution of rainfall in the main, intercepted or sub-catchment
- (f) topography, nature of vegetation, soil type, land use, population density, depth of GWT etc., of the main or intercepted catchment
- (g) the atmospheric and climatic conditions.

The factors (a) to (d) are the basic parameters used in developing correlation curves or mathematical models; factor (d) can be neglected if its contribution is not appreciable, and factors (e) and (f) are taken into account for introducing rainfall and antecedent precipitation index as additional parameters; however, (g) stands as a future factor.

The forecasting methods currently used in the country are:

- (a) based on laws governing the movement of water in the channel, *i.e.*, using the hydrodynamic methods to determine the movement and transformation of flood waves
- (b) based on the analysis of hydrometeorological data of the river basin, *i.e.*, water balance studies taking into account precipitation, the water equivalent of snow cover, soil moisture, ground water and other factors and estimating runoff, which require the use of a computer.

For small catchments, approximate calculations of flood movement and transformation can be made by:

- (i) multiple correlation between stage and discharge observations
- (ii) streamflow routing on river reaches
- (iii) mathematical model

Multiple correlation has the advantage of using parameters like rainfall or antecedent precipitation index. Streamflow routing method includes the effect of channel storage on the shape and movement of flood wave; Muskingum method is generally used. For example, the routing equation developed between Sikanderpur and Rossera on Burhi Gandak (Bihar) is

$$O_2 = 0.612I_1 + 0.033I_2 + 0.355O_1 \quad \dots(16.33)$$

where $K = 36$ hr, $x = 0.3$ and $t = 24$ hr

16.8 MATHEMATICAL MODEL

A linear reservoir attenuates the peak of an inflow hydrograph and a linear channel translates inflow hydrograph in time, which are representative of the physical action performed by the catchment. Hence, a model of a linear reservoir connected in series with a linear channel may be selected in this study. A linear channel is defined by the delay time or the time of travel of the flood wave and is approximately determined with the help of time to peaks of flood events on the upstream and downstream stations of a river reach. Muskingum equation defines the linear reservoir by its storage-discharge relation as

$$S = K[xI + (1 - x)O] \quad \dots(16.34)$$

From the principle of continuity

$$I - O = \frac{dS}{dt}$$

or

$$S_2 - S_1 = \left(\frac{I_1 + I_2}{2}\right)t - \left(\frac{O_1 + O_2}{2}\right)t \quad \dots(16.35)$$

From Eq. (16.34)

$$S_1 = K[xI_1 + (1 - x)O_1]$$

$$S_2 = K[xI_2 + (1 - x)O_2]$$

$$S_2 - S_1 = K[x(I_2 - I_1) - (1 - x)(O_2 - O_1)] \quad \dots(16.36)$$

From Eqs. (16.35) and (16.36),

$$O_2 = C_0I_2 + C_1I_1 + C_2O_1 \quad \dots(16.37)$$

where $C_0 = -\frac{Kx - 0.5t}{K - Kx + 0.5t}$, $C_1 = \frac{Kx + 0.5t}{K - Kx + 0.5t}$

$$C_2 = \frac{K - Kx - 0.5t}{K - Kx + 0.5t} \quad \dots(16.37a)$$

and

$$C_0 + C_1 + C_2 = 1$$

The routing period t (time interval between O_1 and O_2) should be equal to or less than the time of travel through the reach.

Eq. (16.37) for successive time intervals may be written as

$$O_3 = C_0I_3 + C_1I_2 + C_2O_2 \quad \dots(16.38)$$

$$O_4 = C_0I_4 + C_1I_3 + C_2O_3 \quad \dots(16.39)$$

Eq. (16.38) – (16.37) gives:

$$O_3 - O_2 = C_0(I_3 - I_2) + C_1(I_2 - I_1) + C_2(O_2 - O_1) \quad \dots(16.40)$$

Eq. (16.39) – (16.38) gives:

$$O_4 - O_3 = C_0(I_4 - I_3) + C_1(I_3 - I_2) + C_2(O_3 - O_2) \quad \dots(16.41)$$

Assuming the stage (gauge height)—discharge curves as a straight line (as a first approximation), if the slopes of the curve on upstream and downstream are $1/a$ and $1/b$, Fig. 16.18 (a) then

$$\frac{I_2 - I_1}{H_2 - H_1} = \frac{a}{1} \quad \text{and} \quad \frac{I_3 - I_2}{H_3 - H_2} = \frac{a}{1}$$

$$\frac{O_2 - O_1}{G_2 - G_1} = \frac{b}{1} \quad \text{and} \quad \frac{O_3 - O_2}{G_3 - G_2} = \frac{b}{1}$$

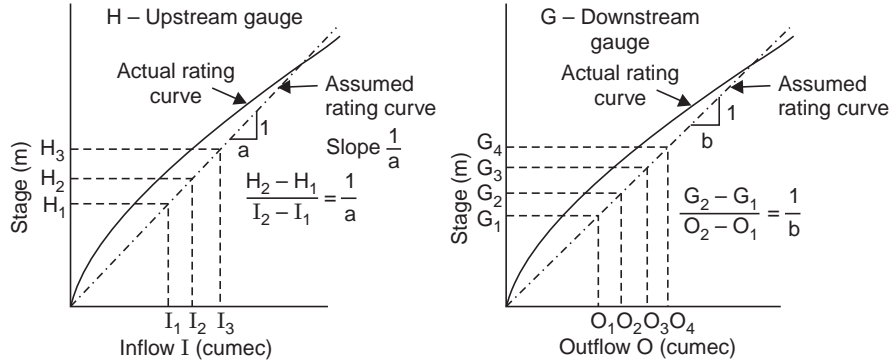

a. Stage – discharge rating curves assumed linear

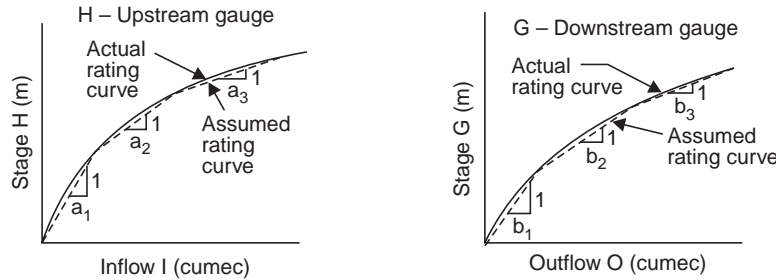

b. Stage–discharge curves divided into three linear parts

Fig. 16.18 Stage-discharge-rating curves Assume

Substituting these in Eq. (16.40)

$$b(G_3 - G_2) = C_0 a(H_3 - H_2) + C_1 a(H_2 - H_1) + C_2 b(G_2 - G_1)$$

or

$$G_3 - G_2 = C_2(G_2 - G_1) + C_0 \frac{a}{b} (H_3 - H_2) + C_1 \frac{a}{b} (H_2 - H_1) \quad \dots(16.42)$$

Similarly, substitution in Eq. (16.41) gives

$$G_4 - G_3 = C_2(G_3 - G_2) + C_0 \frac{a}{b} (H_4 - H_3) + C_1 \frac{a}{b} (H_3 - H_2) \quad \dots(16.43)$$

Eqs. (16.42) and (16.43) may be written as

$$G_3 - G_2 = x_1(G_2 - G_1) + x_2(H_2 - H_1) + x_3(H_3 - H_2)$$

$$G_4 - G_3 = x_1(G_3 - G_2) + x_2(H_3 - H_2) + x_3(H_4 - H_3)$$

where

$$x_1 = C_2, \quad x_2 = C_1 \frac{a}{b}, \quad \text{and} \quad x_3 = C_0 \frac{a}{b}$$

Thus, a number of equations can be obtained from the observed data and solved for x_1 , x_2 and x_3 by the least square technique. Since the number of such equations are very large, from large sets of data, a computer can be used. For example, the equations developed for a straight reach between Muzaffarpur and Rossera on Burhi-Gandak are

Rising stage:

$$G_3 - G_2 = -0.401 (G_2 - G_1) + 2.826 (H_2 - H_1) - 0.94 (H_3 - H_2) \quad \dots(16.44)$$

Falling stage:

$$G_3 - G_2 = - 0.1413(G_2 - G_1) + 0.3018(H_2 - H_1) + 0.6082(H_3 - H_2) \quad \dots(16.45)$$

As a further refinement the stage discharge curves may be divided into linear parts, say three, and the slopes denoted according to the linear ranges in which the stages lie, as shown in Fig. 16.18 (b), and the equations solved by using multiple regression technique.

Contribution due to a major tributary between the base station and the forecasting station has to be taken into account.

The results of flood routing between Sikanderpur (Muzaffarpur) and Rossera by different methods during the 1975 floods are given in Table 16.3 for comparison. It can be seen that the Muskingum method has given more consistent results. A clear picture of forecast and comparison with past values have been found possible only in graphical correlation and minor adjustment based on experience can be done in the predicted value. These are not possible in the mathematical model and also the model cannot give better results in rivers having large scale fluctuations due to existence of control structures, their operation or flashy nature of the stream.

Contribution due to Tributary

Contribution due to a major tributary between the base station and the forecasting station has to be taken into account. For example, three major tributaries of Ganga affect the gauge downstream at Patna, other than its own (Fig. 16.19).

Table 16.3 Comparison of flood forecast results

| Date | Time (hr) | Level upstream (m) | Level downstream (m) | | | | | |
|-----------|-----------|--------------------|----------------------|-----------|-----------------------|------------------|--------------------|----------|
| | | | Date | Time (hr) | Graphical correlation | Muskingum method | Mathematical model | Observed |
| 29.7.1975 | 08-00 | 42.298 | 30.7.1975 | 08-00 | 42.750 | 43.000 | 43.038 | 42.900 |
| 30.7.1975 | 08-00 | 42.903 | 31.7.1975 | 08-00 | 43.600 | 43.750 | 43.527 | 43.623 |
| 31.7.1975 | 08-00 | 43.583 | 01.8.1975 | 08-00 | 44.480 | 44.750 | 44.676 | 44.723 |
| 01.8.1975 | 08-00 | 44.773 | 02.8.1975 | 08-00 | 45.320 | 45.100 | 45.139 | 44.583* |

*The large variation in the last observation is due to number of breaches in the embankment between Muzaffarpur and Rossera.

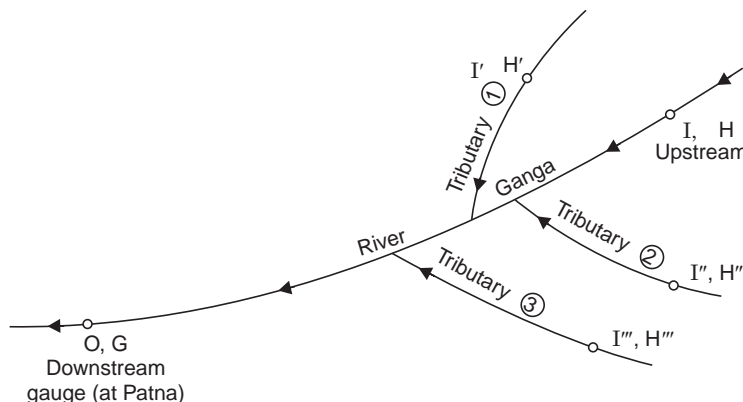

Fig. 16.19 Tributary effect on gauge downstream

In such a case, the modified Muskingum equation can be written as

$$O_2 = C_2 O_1 + C_1 I_1 + C_1' I_1' + C_1'' I_1'' + C_1''' I_1''' + C_0 I_2 + C_0' I_1' + C_0'' I_2'' + C_1''' C_2''' \quad \dots(16.46)$$

Similarly, O_3 can be written and $O_3 - O_2$ can be evaluated. Approximating, its stage (gauge height)-discharge curve, to a straight line, the ultimate equation will be of the form (writing $G_3 - G_2$ as $G_{3,2}$ and so on)

$$G_{3,2} = x_1 G_{2,1} + x_2 H_{2,1} + x_3 H_{3,2} + x_4 H'_{2,1} + x_5 H'_{3,2} + x_6 H''_{2,1} + x_7 H''_{3,2} + x_8 H'''_{2,1} + x_9 H'''_{3,2} \quad \dots(16.47)$$

Number of equations have been formed like this from the observed data and solved for the constants by the least square technique by using a computer. The constants obtained for the forecasting site at Patna for the 1975 floods are given in Table 16.4, and the levels reached in Table 16.5 (compared with values obtained by graphical correlation, which has given better results).

Table 16.4 Constants for forecasting site at Patna

| <i>Constant</i> | <i>Rising stage</i> | <i>Falling stage</i> |
|-----------------|---------------------|----------------------|
| x_1 | 0.5393 | 0.2622 |
| x_2 | 0.1407 | 0.2783 |
| x_3 | -0.0919 | 0.0575 |
| x_4 | -0.1855 | 0.2783 |
| x_5 | 0.1132 | 0.0427 |
| x_6 | -0.0608 | 0.0535 |
| x_7 | -0.1271 | -0.0361 |
| x_8 | 0.0080 | -0.0196 |
| x_9 | 0.1192 | +0.2002 |

Table 16.5 Flood forecast results at Patna during 1975

| <i>Date</i> | <i>Time</i> (hr) | <i>Level</i> upstream (m) | <i>Level downstream (m)</i> | | | | |
|-------------|---------------------|---------------------------------|-----------------------------|---------------------|--|---|-----------------|
| | | | <i>Date</i> | <i>Time</i> (hr) | <i>Graphical</i> <i>correlation</i> | <i>Mathe-</i> <i>matical</i> <i>model</i> | <i>Observed</i> |
| 22.8.1975 | 09-00 | 48.799 | 23.8.1975 | 09-00 | 49.429 | 49.299 | 49.449 |
| 23.8.1975 | 17-00 | 48.679 | 24.8.1975 | 17-00 | 49.929 | 50.089 | 49.969 |
| 24.8.1975 | 01-00 | 49.859 | 25.8.1975 | 01-00 | 49.929 | 55.089 | 49.989 |
| 09.9.1975 | 09-00 | 49.519 | 10.9.1975 | 09-00 | 48.809 | 48.774 | 48.794 |

Chapter 17

INSTANTANEOUS UNIT HYDROGRAPH (IUH)

17.1 IUH FOR A BASIN

An IUH is a direct-runoff hydrograph producing a unit rainfall excess ($P_{\text{net}} = 1 \text{ cm}$) precipitating instantaneously over the catchment; *i.e.*, $i = \frac{1}{t_r}$, $t_r \rightarrow 0$; i increases and the UG becomes more skewed, called IUH, Fig. 16.6 (b). The shape of the IUH resembles a single peaked hydrograph. The properties of the IUH are given by Eq. (16.9); and its time to the peak < time to the centroid of the curve. The main advantage of IUH is that it eliminates the problem of unit duration and restriction of uniform distribution of rainfall in time. It is independent of the duration of the rainfall excess (t_r) and rainfall characteristics, and is indicative of the catchment storage characteristics (like length, shape, slope and storage coefficient), which makes it eminently suitable for theoretical analysis of rainfall-runoff relationship. The IUH is a unique demonstration of a particular catchment response to rain, *i.e.*, 'impulse response'. As the IUH is only an extension of the unit hydrograph concept, it is also based on the principles of linearity and time invariance.

If the IUH of a basin is available, the application of Eq. (16.8) yields the direct runoff due to any storm.

17.2 DERIVATION OF IUH

The IUH can be approximately derived from the S -curve, Eq. (16.7), *i.e.*,

The ordinate of the IUH at any time $t = t_r \times$ Slope of the S -curve derived from the t_r -hr UG at t , *i.e.*,

$$(\text{IUHO})_t = t_r \times \left(\frac{\Delta S}{\Delta t} \right)_t \quad \dots(17.1)$$

The ordinate of the t_r -hr UG at any time $t = \frac{1}{t_r} \times$ area of the IUH between $(t - t_r)$ and t

i.e.,

$$u_t = \frac{1}{t_r} \times \Delta A_t \quad \dots(17.2)$$

If the IUH is assumed **linear** between $(t - t_r)$ and t ,

$$u_t = (\text{IUHO})_{t - \frac{t_r}{2}} \quad \dots(17.3)$$

i.e., average of IUHO at t and $t - t_r$,

which works well only when t_r is small and the peak is not contained within the interval $(t - t_r)$ to t .

Eq. (17.3) can be used to derive a t_r -hr UG from the available IUH, avoiding the construction of the S -curve hydrograph, see Fig. 16.5.

17.3 OTHER METHODS OF DERIVATION OF IUH

Many researchers have made extensive investigation on the derivation of unit hydrograph (UG) since Sherman gave the principle of UG in 1932.

The approaches utilised to develop linear conceptual models of rainfall-runoff relationship may be classified into three groups:

The first group employs a differential equation that supposedly governs the equation of a specified system; **input-output relation**, with rainfall as input and runoff as output (Kulandnia swamy, Chow-1964), see Eq. (16.1).

The second group utilises an arrangement of the so called **conceptual elements** including linear channels and linear reservoirs (Nash 1957), time-area diagrams (Clark 1945), and geomorphological characteristics (Rodriguez-Iturbe and Valdes, 1979).

The third group makes hypothesis about rainfall-runoff relationship more or less on intuitive grounds (Lienhard).

The practical approaches of Nash and Clark are discussed here and other methods proposed by Dooge, Diskin, etc., are not considered here.

Considerable work has been reported in the literature on the non-linear unit hydrograph theory, which is beyond the scope of this book.

17.4 NASH CONCEPTUAL MODEL

Nash considered that the IUH can be obtained by routing the instantaneous inflow through a cascade of linear channels (n numbers) with equal storage coefficient (Fig. 16.7). The out flow from the first reservoir is considered as inflow into the second reservoir, and so on. The outflow from the n^{th} reservoir yields the IUH given by

$$u(t) = \frac{1}{k \Gamma n} e^{-\frac{t}{k}} \left(\frac{t}{k}\right)^{n-1}, \quad \Gamma n = (n-1)! \quad \dots(17.4)$$

The value of the parameter n , which is a **shape parameter**, is a measure of the catchment channel storage, which defines the shape of the IUH. A lower value of n yields a higher peak of IUH because of less storage flow attenuating the peak flow; a higher value of n leads to a lower peak of IUH signifying higher storage for attenuating peak flow. The parameter K (delay time, hr), which is a **scale parameter**, represents the dynamics of rainfall-runoff process in the catchment. A smaller K -value reflects a lower time to peak of the runoff hydrograph and a higher K -value reflects a long time to peak.

The two parameters n and k may be computed by making an analysis of the observed rainfall-runoff data on the catchment as follows:

$$\text{The first moment of the IUH about the origin } (t = 0): M_1 = nk \quad \dots(17.5)$$

The second moment of the IUH about the origin $(t = 0)$:

$$M_2 = n(n+1)k^2 \quad \dots(17.6)$$

By routing through the cascade of n -reservoirs, it can be shown that

$$MQ_1 - MI_1 = nk \tag{17.7}$$

$$MQ_2 - MI_2 = n(n + 1)k^2 + 2nk MI_1 \tag{17.8}$$

where MQ_1, MQ_2 are the first and second moments of direct runoff about the origin and MI_1, MI_2 are the first and second moments of the effective rainfall (rainfall excess P_{net}) about the origin.

The parameters n and k may be evaluated by solving these two equations as illustrated in the Example 17.1. Making use of these two parameters an IUH can be derived for a catchment of area eq. $A \text{ km}^2$; and also a t_r -hr UG, as illustrated in Example 17.2; i.e., from the available rainfall-runoff data on a catchment of area A , and IUH and a t_r -hr UG can be derived, for which the procedure involves the steps of both the Examples, 17.1 and 17.2.

Example 17.1 *The effective rainfall due to a 4-hr storm in the successive hours are: 2.6, 2.5, 2.3 and 2.4 cm. The resulting DRO's in the successive hours are: 3, 15, 26, 40, 50, 35, 25, 20, 15, 10, 7, 4, 3 and 1 cumec. Determine the values of n and k .*

Solution

Step 1 Evaluate the first and second moments of P_{net} about the origin, i.e., $t = 0$ (commencement of P_{net} and DRO)

$$MI_1 = \frac{2.6 \times 0.5 + 2.5 \times 1.5 + 2.3 \times 2.5 + 2.4 \times 3.5}{2.6 + 2.5 + 2.3 + 2.4} = \frac{19.2 \text{ cm} \cdot \text{hr}}{9.8 \text{ cm}} \approx 2 \text{ hr}$$

$$MI_2 = \frac{2.6 \times 0.5^2 + 2.5 \times 1.5^2 + 2.3 \times 2.5^2 + 2.4 \times 3.5^2}{9.8} = \frac{49.75 \text{ cm} \cdot \text{hr}^2}{9.8 \text{ cm}} \approx 5 \text{ hr}^2$$

Step 2 Evaluate the first and second moments of Q_i about the origin;

$$Q_i = DRO_i, \quad Q\bar{t} = \Sigma Q_1 t_1, \quad MQ_1 = \bar{t} = \frac{\Sigma Q_1 t_1}{Q}, \quad Q = \Sigma Q_1 = \Sigma DRO$$

$$\text{Similarly, } Q\bar{t}^2 = \Sigma Q_1 t_1^2; \quad MQ_2 = \bar{t}^2 = \frac{\Sigma Q_1 t_1^2}{Q}$$

Table 17.1 To evaluate MQ_1 and MQ_2

| Time t (hr) | DRO (cumec) (given) = Q | $Q \times t$ (cumec-hr) | $Q \times t^2$ (cumec-hr ²) |
|------------------|---------------------------------|----------------------------|--|
| 0 | 0 | 0 | 0 |
| 1 | 3 | 3 | 3 |
| 2 | 15 | 30 | 60 |
| 3 | 26 | 78 | 234 |
| 4 | 40 | 160 | 640 |
| 5 | 50 | 250 | 1250 |
| 6 | 35 | 210 | 1260 |
| 7 | 25 | 175 | 1225 |
| 8 | 20 | 160 | 1280 |
| 9 | 15 | 135 | 1215 |
| 10 | 10 | 100 | 1000 |

(Contd.)...

| | | | |
|------------------|---|--------------------|------------------------|
| 11 | 7 | 77 | 847 |
| 12 | 4 | 48 | 576 |
| 13 | 3 | 39 | 507 |
| 14 | 1 | 14 | 196 |
| 15 | 0 | 0 | 0 |
| $\Sigma Q = 254$ | | $\Sigma Qt = 1472$ | $\Sigma Qt^2 = 102.93$ |

$$MQ_1 = \bar{t} = \frac{1472}{254} = 5.8 \text{ hr}, \quad MQ_2 = \bar{t}^2 = \frac{10293}{254} = 40.5 \text{ hr}^2$$

Eq. (17.7): $nk = MQ_1 - MI_1 = 5.8 - 2 = 3.8 \text{ hr}$

Eq. (17.8): $MQ_2 - MI_2 = n(n + 1)k^2 + 2 nk MI_1$
 $40.5 - 5 = nk^2(n + 1) + 2 \times 3.8 \times 2$
 $35.5 = n^2k^2 + nk^2 + 15.2$
 $nk^2 = 35.5 - 15.2 - (3.8)^2 = 5.87$

$$k = \frac{nk^2}{nk} = \frac{5.87}{3.8} = 1.55$$

$$n = \frac{nk}{k} = \frac{3.8}{1.55} = 2.45 \approx 2 \text{ (whole number)}$$

Example 17.2 Derive an IUH and a 2-hr UG (UGO at 2-hr intervals) for a catchment of 240 km², having $n = 3$ and $k = 5$ hr.

Solution NASH Model, Eq. (17.4):

$$u(t) = \frac{1}{k\Gamma n} \cdot e^{-\frac{t}{k}} \cdot \left(\frac{t}{k}\right)^{n-1}$$

$$k = 5 \text{ hr}, n = 3 \text{ and } \Gamma n = (n - 1)! = (3 - 1)! = 2! = 2 \times 1 = 2$$

$$u(t) = \frac{1}{5 \times 2} \cdot e^{-\frac{t}{5}} \cdot \left(\frac{t}{5}\right)^{3-1} = \frac{1}{10} e^{-t/5} \left(\frac{t}{5}\right)^2$$

Table 17.2 IUHO and 2-hr UGO computation

| Time | | IUHO | | | 2-hr UGO (cumec) (by averaging) | |
|----------------|---------------|--------------------|------------------------------|--|---------------------------------------|---|
| $t(\text{hr})$ | $\frac{t}{5}$ | $e^{-\frac{t}{5}}$ | $\left(\frac{t}{5}\right)^2$ | $u(t)$ (cm/hr) $= \frac{(3) \times (4)}{10}$ | | $u(t)$ (cumec) $(5) \times 2.78 \times 240$ $= (5) \times 668$ |
| 1 | 2 | 3 | 4 | 5 | 6 | 7 |
| 0 | 0 | 1 | 0 | 0 | 0 | 0 |
| 2 | 0.4 | 0.67 | 0.16 | 0.0107 | 7.17 | $\frac{0 + 7.17}{2} = 3.58$ |
| 4 | 0.8 | 0.45 | 0.64 | 0.0288 | 19.4 | $\frac{19.4 + 7.17}{2} = 13.3$ |

(Contd.)...

| | | | | | | |
|----|-----|---------|-------|--------|------------------|-----------------|
| 6 | 1.2 | 0.30 | 1.44 | 0.0432 | 28.8 | 24.1 |
| 8 | 1.6 | 0.20 | 2.56 | 0.0512 | 34.2 | 31.5 |
| 10 | 2.0 | 0.135 | 4.00 | 0.0542 | 36.2 | 35.2 |
| 12 | 2.4 | 0.091 | 5.76 | 0.0524 | 34.9 peak of IUH | 35.5 peak of UG |
| 14 | 2.8 | 0.061 | 7.84 | 0.0480 | 33.2 | 34.0 |
| 16 | 3.2 | 0.041 | 10.24 | 0.0420 | 28.0 | 30.6 |
| 18 | 3.6 | 0.027 | 12.96 | 0.0350 | 24.4 | 26.2 |
| 20 | 4.0 | 0.0183 | 16.00 | 0.0293 | 19.6 | 22.0 |
| 22 | 4.4 | 0.0122 | 19.36 | 0.0236 | 15.7 | 17.6 |
| 24 | 4.8 | 0.0082 | 23.04 | 0.019 | 12.7 | 14.2 |
| 26 | 5.2 | 0.0055 | 27.04 | 0.0149 | 9.95 | 11.32 |
| 28 | 5.6 | 0.0037 | 31.36 | 0.0116 | 7.75 | 8.85 |
| 30 | 6.0 | 0.0025 | 36.00 | 0.009 | 6.0 | 6.87 |
| 32 | 6.4 | 0.0017 | 40.96 | 0.007 | 4.66 | 5.33 |
| 34 | 6.8 | 0.0011 | 46.4 | 0.005 | 3.34 | 4.00 |
| 36 | 7.2 | 0.00075 | 51.8 | 0.004 | 2.67 | 3.00 |

Nash, from his study on some gauged catchments in UK, established a correlation between the IUH parameters n and k , and the basin parameters like length of main stream (L , miles), slope of the basin (S , parts per 1000) and the area (A , sq. miles), as

$$n = 2.4 L^{0.1}, \quad K = \frac{11 A^{0.3}}{L^{0.1} S^{0.3}}$$

Using the above relations, the IUH of any ungauged basin in a hydrometeorologically homogeneous region can be obtained.

17.5 CLARK'S MODEL

Clark in 1945, was the first to use the concept of IUH. The Clark method requires three parameters to calculate IUH: t_c , the time of concentration for the basin; K , storage coefficient, and a time-area diagram (TAD).

The value of K is usually obtained by using the slope of the recession curve (which is negative) at the point of inflection (Fig. 16.10). At the inflection point, the inflow into the channel has ceased and beyond this point, the flow is entirely due to withdrawal from the channel storage. From the continuity equation:

$$\begin{aligned} I - Q &= \frac{dS}{dt}, & Q &= O, \text{ outflow} \\ I &= 0, & -Q &= \frac{dS}{dt}, \quad S = KQ \\ \therefore & & -Q &= K \frac{dQ}{dt} \quad \text{or} \quad K = - \frac{Q}{dQ/dt} \end{aligned} \quad \dots(17.9)$$

$$\text{For the recession limb, Fig. 16.10, } Q_t = Q_0 e^{-t/k}, \quad k = \frac{t}{\ln(Q_0/Q_t)} \quad \dots(17.9 a)$$

$$\text{Clark gave the empirical relation as } K = \frac{CL}{\sqrt{S}}$$

and Linsley further modified this as
$$K = \frac{bL \sqrt{A}}{\sqrt{S}}$$

K in hr, L in miles, A in sq. miles, constants $C = 0.8$ to 2.2 , $b = 0.04$ to 0.08 . The value of K may be estimated from the above relations in case no hydrograph is available for the basin.

17.6 DRAWING ISOCHRONES AND TIME-AREA DIAGRAM (TAD)

The basin is divided into zones (sub-areas A_r , km²) by drawing **isochrones** (Fig. 16.11). An isochrone is a line joining all points having the same travel time. A water particle on a 8-hr isochrone will take 8 hr to reach the basin outlet.

For drawing the isochrones, the profile of the longest water course (*i.e.*, main water course) is plotted as “elevation vs, distance” from the basin outlet. The total length of the main channel is then divided into N reaches, keeping in mind the slopes in different reaches, since

the time of travel (t) is proportional to L/\sqrt{S} , *i.e.*, $t = \frac{KL}{\sqrt{S}}$, where K is the constant of propor-

tionality. Then the elevation of each portion is transferred to the contour map of the catchment.

An initial estimate of the time of concentration (t_c hr) may be obtained by using Kirpich's formula (L in km)

$$t_c = 0.06628 L^{0.77} S^{-0.385} \quad \dots(17.10)$$

and from this the value of K can be determined.

At the points transferred to the contour map, curves are drawn joining all the points having specified travel times, which are called isochrones. The areas between the successive isochrones are planimetered and the time-area diagram (TAD) is prepared from the isochronal map (Fig. 16.12).

17.7 CLARK'S METHOD

In the Clark's approach, the ordinates of TAD are converted to volume rate of runoff in cumec for unit rainfall excess, *i.e.*, 1 cm, occurring instantaneously and uniformly over the catchment, as

$$I = \frac{1 \text{ cm } (A_r \times 10^6)}{100 t \times 60 \times 60} = 2.78 \frac{A_r}{t} \text{ cumec or m}^3/\text{s} \quad \dots(17.11)$$

where t = Computation time interval, hr of TAD, *i.e.*, isochrone interval or routing period

$$t_c = t \times N, N = \text{No. of inter-isochrone areas or sub areas, } A_r \text{ km}^2$$

$$\text{Catchment area } A = \Sigma A_r$$

$$\text{In Example 16.1, } t_c = 1 \text{ hr} \times 9 \# = 9 \text{ hr} \approx t_i, N = 9$$

Note: 8 Isochrones are drawn to yield 9 zones ($N = 9$) or Subareas A_r .

$$t = \frac{t_c}{N} \quad \dots(17.12)$$

The inflow (I) from the sub area A_r calculated as above, *i.e.*, the resulting translation hydrograph is then routed through a linear reservoir to simulate the storage effects of the basin; Clark's method utilises Muskingum method of routing through a linear reservoir, *i.e.*, $x = 0$ in Eq. (9.9); $S = KQ$, $Q = O$.

The general equations for the linear reservoir is (See Eq. (16.21))

$$\begin{aligned} \text{IUHO} = O_2 = Q = C'I + C_2O_1, \quad O_1 = Q_1 \\ \text{i.e.,} \quad Q_2 = C'I + C_2Q_1, \quad \text{for IUH derivation} \end{aligned} \quad \dots(17.13)$$

The routing coefficients are obtained from (see Eqs. 16.20, 16.20a, 16.21)

$$C' = \frac{t}{k + t/2}, \quad C_2 = \frac{k - t/2}{k + t/2} \quad \therefore C' + C_2 = 1 \quad \dots(17.14)$$

The resulting IUHO (IUH ordinates) are averaged at t_r intervals to produce a t_r -hr UG, Ex. 16.1.

Note: u_t of t_r -hr UG = $u_{\left(t - \frac{t_r}{2}\right)}$ of IUH = $\frac{u_t + u_{t-t_r}}{2}$ of IUH, i.e., by averaging IUHO, assuming linear.

Example 17.3 The recession ordinates of the flood hydrograph (FHO) for the Lakhwar dam site across river Yamuna are given below. Determine the value of K .

| | | | | | | | | | |
|--------------|------|-----|-----|-----|-----|----|----|----|----|
| Time (hr): | 30 | 36 | 42 | 48 | 54 | 60 | 66 | 72 | 78 |
| FHO (cumec): | 1070 | 680 | 390 | 240 | 150 | 90 | 45 | 30 | 20 |

Solution Eq. (5.1) can be expressed in an alternative form of the exponential decay as

$$Q_t = Q_0 e^{-t/k}, \quad \text{when } K = \frac{t}{\ln(Q_0/Q_t)}$$

' Q vs. t ' is plotted on the semi-log paper (Fig. 17.1). K is the slope of the recession-flood-hydrograph plot.

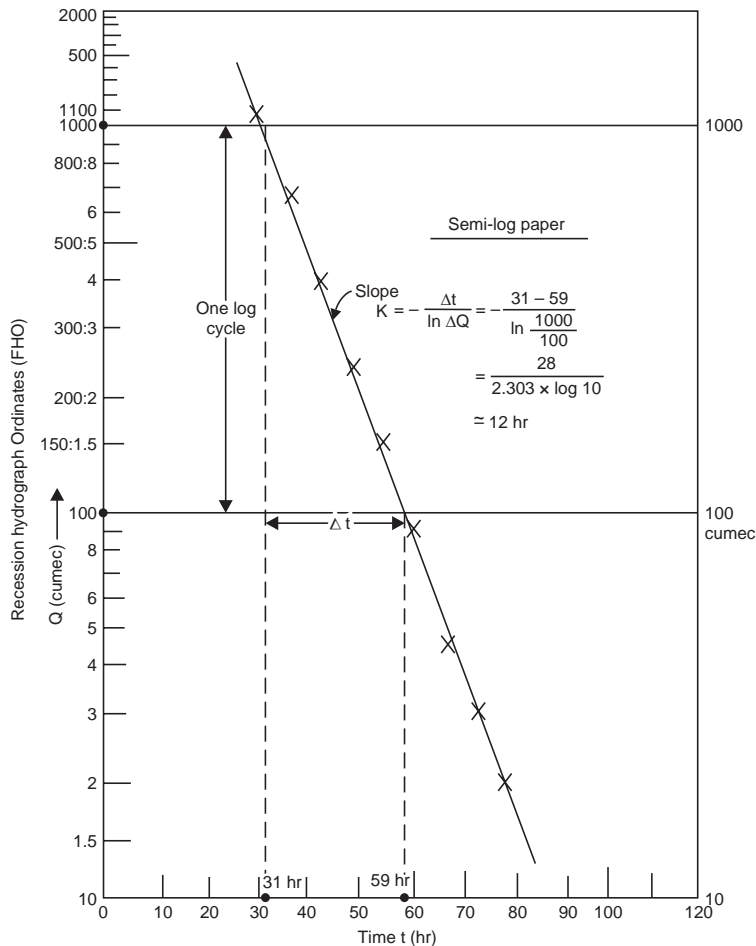

Fig. 17.1 Recession flood hydrograph

$$K = \frac{\Delta t}{\Delta \ln Q} = \frac{\Delta t}{2.303 \log \frac{1000}{100}}, \quad \Delta t = t_{1000} - t_{100} \text{ cumec}$$

$$= 31 \text{ hr} - 59 \text{ hr, from the plot}$$

$$K = \frac{31 - 59}{2.303 \times 1} = -\frac{28}{2.303} = -12.15, \text{ say } \mathbf{12 \text{ hr}}$$

Example 17.4 The isochronal map of Lakhwar damsite catchment, Fig. 17.2 (a) has areas between successive 3 hr isochrones as 32, 67, 90, 116, 135, 237, 586 and 687 km². Taking $k = 12$ hr (as determined in Ex. 17.3), derive the IUH of the basin by Clark’s approach and hence a 3-hr UG.

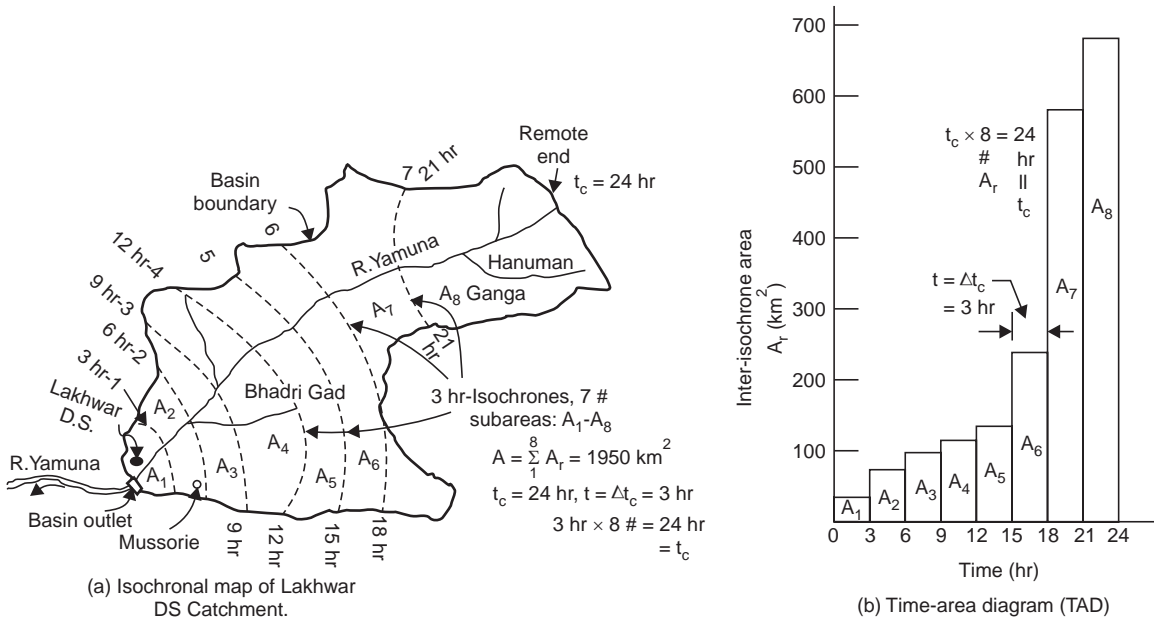

Fig. 17.2 Isochrones and TAD for Lakhwar Dam Site

Solution

Note $A = \Sigma A_r = 1950 \text{ km}^2$

$$t_c = t \times N = 3 \times 8 = 24 \text{ hr}, \quad K = 12 \text{ hr}$$

No. of isochrones = $N - 1 = 8 - 1 = 7\#$

Computation interval $t = \Delta t_c$ between successive isochrones = $3 \text{ hr} = \frac{24}{8} = \frac{t_c}{N}$

Clark’s approach Eq. (17.13):

$$Q_2 = C'I + C_2Q_1$$

$$C' = \frac{t}{k + t/2} = \frac{3}{12 + \frac{3}{2}} = 0.2222, \quad C_2 = \frac{k - t/2}{k + t/2} = \frac{12 - 3/2}{12 + 3/2} = 0.7778$$

Check: $C' + C_2 = 0.2222 + 0.7778 = 1 \quad \therefore \text{O.K.}$

From the sub areas A_r , Eq. (17.11): $I = 2.78 \frac{A_r}{t} = 2.78 \times \frac{A_r}{3} = 0.9267 A_r$

Clark's: $Q_2 = C'I + C_2Q_1$, $C_2Q_1 = 0.7778 Q_1$ $Q_2 = IUHO$

$C'I = 0.2222 \times 0.9267 A_r = 0.203 A_r$

Table 17.3 Computation of IUH by Clark's approach and hence 3-hr UG.

| 1 | 2 | 3 | 4 | 5 | 6 |
|--------------|-------------------------------------|--|---|--|--|
| Time (hr) | A_r , (km^2) (from TAD) | $C'I$ $= 0.203 A_r$ $= (2) \times 0.203$ | C_2Q_1 $= 0.7778 Q_1$ $= (5) \times 0.7778$ previous | $IUHO$ Q_2 (cumec) $= C'I + C_2Q_1$ $= (3) + (4)$ | 3-hr UGO (cumec) (by averaging) |
| 0 | 0 | 0 | | 0 | 0 |
| 3 | 32 | 6.4 + → | 0 ← × 0.78 | 6.4 | $\frac{0 + 6.4}{2} = 3.2$ |
| 6 | 67 | 13.5 + → | 5.1 ← × 0.78 | 18.6 | $\frac{6.4 + 18.6}{2} = 12.5$ |
| 9 | 90 | 18.0 + → | 14.9 ← × 0.78 | 33.0 | 25.3 |
| 12 | 116 | 23.3 | 26.4 | 49.7 | 41.3 |
| 15 | 135 | 27.0 | 39.7 | 66.7 | 58.2 |
| 18 | 237 | 47.5 | 53.0 | 100.5 | 83.6 |
| 21 | 586 | 117 | 80.0 | 197.0 | 148.8 |
| 24 | 687 | 137.5 | 157 | 294.5 peak of IUH | 245.7 |
| 27 | $\Sigma A_r = 1950 km^2$ | 0 | 230 | 230 | 262.2 (peak of UG) |
| 30 | | 0 | 179 | 179 | 204.5 |
| 33 | | 0 | 139.5 | 139.5 | 159.2 |

Plot Col. (5) vs. col (1) to get IUH, and Col (6) vs. col. (1) to get 3-hr UG. Note that the two peaks are staggered by 3 hr; *i.e.*, IUH is more skewed.

QUESTIONS

- 1 Define IUH and state its important properties illustrated in a neat sketch. What are the advantages of IUH over a UG of finite duration?
- 2 Determine the values of n and k , and hence derive an IUH for the drainage basin in Example 5.2. State its peak and time to peak.
- 3 For the IUH obtained in (2) above, derive a 6-hr UG and compare with that obtained in Example 5.2.
- 4 Derive an IUH by Clark's approach and hence a 2-hr UG for a catchment of $140 km^2$, $t_c = 18$ hr, $K = 12$ hr. The catchment was divided into 9 zones by drawing 8 isochrones. The areas planimetered between the successive 2-hr isochrones are 8 (near outlet) 12, 25, 35, 22, 16, 10, 8 and 4 (remote end) in km^2 .

- 5 (a) Explain the concept of Clark's IUH.
- (b) The shape of a catchment can be approximated to a square with diagonal of 60 km. The main channel is nearly along a diagonal; the isochrones may be assumed perpendicular to the main channel. The travel speed along the main channel may be taken as 5 km/hr. Derive the IUH for the basin with $K = 5$ hr
- Hint:** $t_c = 12$ hr. Divide the diagonal into 6 parts to obtain successive 2-hr isochrones.
- 6 The IUH of a basin can be approximated to a triangle of base 36 hr and peak of 30 cumec at 9 hr from the start. Derive a 3-hr UG for this basin.

Chapter 18

CLLOUD SEEDING

18.1 CONDITIONS FOR CLOUD SEEDING

Between the vanishing forests and the reluctant clouds, the draught has advanced menacingly. This is where cloud seeding will help win the battle.

Cloud seeding was discovered as accidentally as most scientific discoveries. In 1946, when Dr. Vincent J. Schaefer working with GE in New York was trying to create artificial clouds in a chilled chamber, he placed dry ice inside to cool the chamber. Water vapour inside formed a cloud around the dry ice. That is pretty much how in a normal cloud ice crystals form when cold water contacts particles of dust, salt or soot.

In cloud seeding, silver iodide or other agents like common salt are introduced, which mimic the ice crystal; the number of these nuclei available is increased and these can take in more moisture in the cloud and form raindrops, which otherwise would not have formed. This increased condensation and freezing releases a large amount of heat that makes clouds more buoyant and extends them sideways and upwards. As clouds grow taller, their updraft increases, they draw in more moist air from the near surface and their size increases further.

Enlarged clouds then encroach over several smaller clouds nearby and grow further, and hence the duration and quantity of rainfall will increase.

Rain clouds 6–9 km high and containing 0.5 mcm (million cubic meter) of water seeded with silver iodide can be raised by 2 km and their water content increased to >1 mcm. Seeding of multi-cell clouds leads to very high precipitation as compared to single cell clouds. Cloud seeding has been carried out quite successfully in several countries including USA, Israel, Russia, Canada, Australia and India. Clouds have been seeded at a height of around 2 km above sea level.

However, it should be known that cloud seeding can only accelerate and increase the amount of rainfall and not create rainfall, when the conditions are not favourable, as what happened when seeding was done in 1975 in Linganamakki area of Sagar (Shimoga Dist., Karnataka); the seeded clouds had drifted away do to wind; also the clouds were floating below 1.2 km level.

Cloud seeding can not be done in the areas where there are no chouds as it can only make the bad clouds to yield more.

The conditions favourable for cloud seeding are:

- (i) the lower surface of the clouds should be within 1 km from the ground surface.

- (ii) the relative humidity must be high, >75% and wind velocity < 15–20 km/hr.
- (iii) the temperature inside the cloud should be less than the freezing point of water.

Cloud seeding can be done either from above or from below, as illustrated in the following.

Seeding from above is resorted when a large area is concerned. This requires special aircraft that can travel to heights where precipitation occurs, and can carry large loads of seeding material. The four major requirements are:

- (i) equipment of cloud-condensation-nuclei measurement,
- (ii) facility for photographing of cloud growth,
- (iii) temperature measurement, and
- (iv) 2-D Doppler Echo measurement of precipitation particles.

The weather radars are setup at land surface at air bases for locating the movements of rain potential clouds and will cover nearly 400 km². A Doppler weather radar with a range of 200–400 km was setup at air bases of Bidar, Hubli and Jakkur (in Karnataka).

The operation of monitoring the rain efficient clouds are done through the computer-aided system on board the cloud seeding aircraft with the support of the communication devices from the base station. The turbo-prop aircraft titled Piper-PA 31 with special equipment and extra fittings arrived from the US-based Weather Modifications Inc. (WMI) for enhancing the rainfall by 25% in the drought-hit districts of Karnataka following the failure of rainfall for the third consecutive year at a cost of Rs. 5.6 crore, in August 2003. The tender proposal was prepared by experts from IITM and IMD.

The WMI, a cloud seeding company based in Fargo, north Dakota in the USA, has carried out cloud seeding operations in fifteen countries and most of their operations were successful. WMI had quoted Rs. 8 crore for the cloud seeding operations in Karnataka in August 2003. WMI's competitor was Atmospheric INC. (AI), which is also a US-based company.

Experts of WMI started the 90-day "Project Varuna" from August 18, 2003. The WMI had the radar and control room at Agni Aerosports in Jakkur Airfield at Bangalore. The radar to scan for rain-bearing clouds in the range of 200 km and give information to the pilot and crew of the aircraft, who in turn fly to the region and carry out the cloud seeding operations.

While the popular form of cloud seeding is through spraying from aircraft, **approach from below** also has been used, as in Hyderabad in July 1993. Using ground generators consisting of hot ovens and a blower, coal is heated to 1200 °C and silver iodide sprinkled. The rising fumes went straight into the sagging clouds. In minutes-there was a downpour for half an hour resulting in increased waterlevel in Osman Sagar Lake (Hyderabad). The samples showed traces of silver iodide proving the rains were due to the seeding.

18.2 CLOUD SEEDING TECHNIQUE

When nature is reluctant to produce ice in super-cooled clouds, it is possible to lend a hand by providing the ice nuclei that nature is lacking. This is commonly called **cloud seeding** and it could be done with a variety of ice-inducing agents like silver iodide or sodium chloride.

When silver iodide is used, small amounts are burned in flares or solution at the cloud top or in the updrafts at the cloud base with the help of aircraft flying, the rapid development of large number of small ice droplets soon follows.

When sodium chloride is sprayed on to the clouds with the help of aircraft, it precipitates the cloud particles, which are usually of 100 microns, μ , ($1000 \mu = 1 \text{ mm}$), into larger

particles upto 6-7 mm. When the particles increase in size, they can not hold together and come down to the earth resulting in rain. This precipitation also happens naturally during normal rains.



Fig. 18.1 A hygroscopic cartridge being burnt to demonstrate the process of cloud seeding, which was inaugurated at the Jakkur airfield in Bangalore on Monday-Aug. 2003

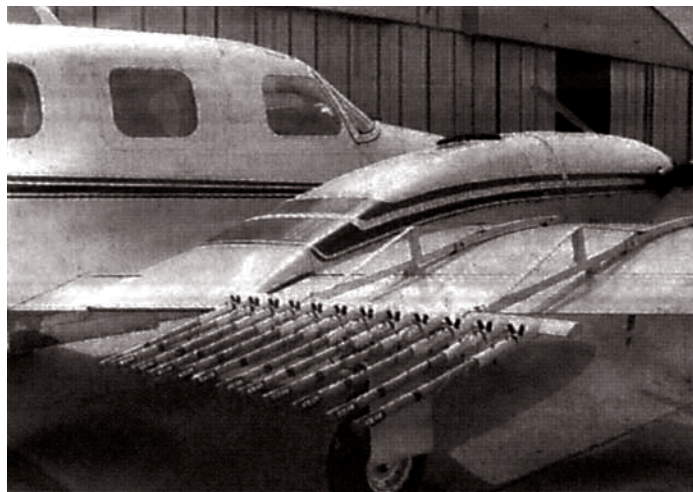

Fig. 18.2 An aircraft fitted with flares containing nuclei used for cloud seeding operation can be seen in this file photo

Cloud seeding however, artificially presses the cloud particles to precipitate and result in rain. The chances of rains increase by about 30% due to cloud seeding.

Though sodium chloride is normally used in the tropical region which gets **Warm rains** (where small cloud particles become bigger resulting in rain), silver iodide is used in **cold rains** (which occur in high altitudes) in which water particles in cloud freeze and in turn result in rain. Silver iodide enhances the chances of water particles freezing.

Both the chemicals were used for cloud seeding in Karnataka during August 2003.

18.3 CLOUD SEEDING OPERATION

To begin with, one has to identify the clouds, which can not yield rains due to shortage of (ice/water) nuclei; after that, the exact number of nuclei to be added to such clouds to make them yield rains, has to be found out.

Then, the technical team will calculate the quantity of silver iodide that has to be added to the clouds to get the required increase in nuclei. This could be done through computer-aided system on board the aircraft with the input as well as communication from the base-station. The addition of nuclei would be facilitated by burning silver iodide flares. The crew may have of six members—two pilots, two meteorologists and two technicians for carrying out the cloud seeding operations. The aircraft should be capable of 6 hr endurance at operational altitudes, having computer-aided control for scientific management of cloud seeding operations.

Cloud seeding is not so costly and the **benefit-cost ratio** may be around 60: 1. Several scientists are still sceptical as to how effective the cloud seeding is! Is the rain in most cases due to the seeding or was it anyway poised to rain, they ask. But one thing they all agree, is that there have been no negative effects from cloud seeding so far with regard to polluting the environment or the chemicals used. The criticisms are about the possibility of creating bad weather or floods; and of course increasing rainfall in one region is at the expense of rainfall in a neighbouring local region.

18.4 RECENT CASE HISTORY

Russian air force's special squad air craft was pressed into service on Monday (9th May 2005) to clear cloud-cover over MOSCOW, so that no rain clouds dampen the Victory Day celebrations (marking the 60th anniversary of the Allied Victory over Nazi Germany in World War II) attended by leaders of 53 nations.

At 5.30 A.M. (local time), 12 Antonov An-12 and Ilyushin IL-18 aircraft took position in the sky over Moscow, divided in 10 zones, as a cyclone from the west advanced towards the capital.

Flying at 3-8 km altitude, the planes sprinkled various chemicals including silver iodide, liquid nitrogen, dry ice (frozen carbon dioxide) and even ordinary cement to seed the clouds at a distance of 50-150 km away. By 10 A.M. sharp at the start of the military parade, rain had stopped in Red Square and the sky was clear for the impressive flypast by Sukhoi and MIG fighters. For the first time in Moscow, computer-designed fireworks were used on Monday night, and the efforts were to keep the sky clear till date in the night.

Appendix A

SNOWMELT RUNOFF

In most parts of the Western Countries, snowmelt produces the major portion of the annual runoff. The high altitudes in the Himalayan range are snow covered and there is an appreciable snowmelt runoff in the rivers, which originate from the Himalayan range.

Snow cover is usually more variable than precipitation within a given area. The hydrologist is concerned with the structure attained by the snow just prior to melting, the area and depth of snow pack, the rates of snowmelt, and the resulting runoff in the stream due to snowmelt and concurrent rainfall. The measurements of snow depths can be done by snow survey, snow gauging, and remote sensing by satellite.

Physics of Snowmelt

The sources of energy to melt snow may be broadly classified as:

- (i) radiant heat from the sun,
- (ii) latent heat of vapourisation released by condensation of water vapour, and
- (iii) heat by conduction from the environment of snow, such as from the ground, rainfall, and air.

The snow pack may also lose heat to its environment by radiation, sublimation and by conductivity. The melting of snow, due to the interactions of the various phenomena of heat exchange, makes it one of the most complex in the field of hydrology.

The most common source is solar radiation. The amount of radiation effective in the melting of snow is dependent on its reflectivity or albedo. About 90 per cent of the radiation incident on clean, fresh snow is reflected (without causing melt), while lesser amounts are reflected from old and dirty snow.

Conduction from still air causes very little melt (due to its low heat conductivity). Turbulence resulting from wind, brings large quantities of warm air into contact with the snow, and heat exchange takes place. If the dew point of the air is less than the snow-surface temperature, the vapour pressure of snow (e_s) is greater than that of the air (e_a) resulting in evaporation from the snow surface; on the other hand, if the dew point is above freezing, condensation on the snow occurs, with consequent release of latent heat.

Snow melt (M_s) due to convection is proportional to the difference in temperature of the air (T_a) and the snow (T_s), while due to conduction the snowmelt is proportional to the vapour pressure gradient ($e_a - e_s$); both the two processes are influenced by the wind speed (V_w) and are given by

$$M_s \text{ (air-convection)} = k_c(T_a - T_s)V_w$$

$$M_s \text{ (vapour-condensation)} = k_v(e_a - e_s)V_w$$

where $T_s = 0^\circ\text{C}$

e_s = saturation vapour pressure in *mb* at 0°C (= 6.11)

k_c, k_v = exchange coefficients

V_w = average wind speed

If the vapour pressure of the air is higher than that of ice at 0°C , the moisture (vapour) brought by turbulence in the air, condenses on the snow surface. Since the condensation of water at 0°C is 596 cal/g and the heat of fusion of ice is 80 cal/g, the condensation of 10 mm of water vapour on the snow surface causes $\frac{596}{80} \times 10 = 7.5 \times 10 = 75$ mm of melt water from the snow. Hence, the wind speed (which causes turbulence) is an important factor in computing snowmelt.

Rainfall, at temperature above freezing, causes snowmelt and is given by the simple calorimetric equation

$$M_s = \frac{PT_w}{80}$$

where

M_s = snowmelt (mm)

P = rainfall (mm)

T_w = wet-bulb temperature ($^\circ\text{C}$)

If $T_w = 20^\circ\text{C}$, 20 mm of rain will cause $\frac{20 \times 20}{80} = 5$ mm of melt water from the snow.

Thus rainfall is less effective in causing snow melt, while the strong winds, warm air and high humidity which accompany rainfall cause appreciable melt during rainstorms.

Forest cover, land slope (topography), influence wind, temperature and humidity of the air, and appreciably affect the amount of radiation incident on snow; hence, the importance of environment on the snowmelt.

If the basin is covered with a fairly uniform depth of snow, the snowmelt can be estimated by the use of the 'degree-day factors'. The degree-day factor is the depth of water melted from the snow in mm per degree-day, *i.e.*, mean daily temperature of 1°C above freezing temperature (0°C), and can be determined by dividing the volume of streamflow as a result of snowmelt during a certain period by the total degree-days for the period. The factor usually ranges from 2-7 mm/degree-day. Since solar radiation, humidity and wind affect snowmelt, some variation in the degree-day factor from day to day may be expected and seems to increase as the melting period progresses*, Fig. A-1. There is a time lag between the snowmelt and the streamflow observed, so that the latter is not a measure of the former.

*Linsley R. K., A Simple Procedure for Day-to-Day Forecasts of Runoff from Snow Melt, Trans. Am. Geophys. Union, Vol. 24, pp. 62-67, 1943.

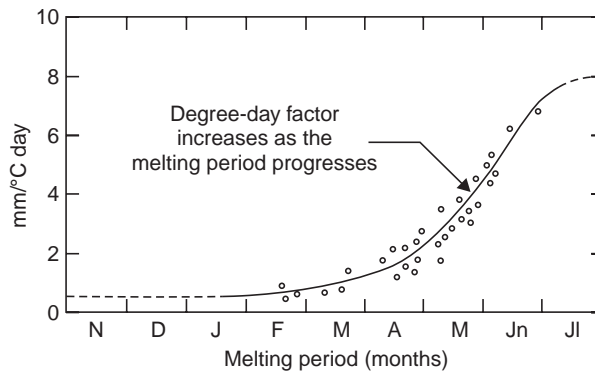

Fig. A-1 Degree-day factor variation (after Linsley, 1943)

Since snowmelt occurs at higher altitudes and the temperature varies with the altitude, the records of a single station do not indicate the actual degree-days unless the station is located at mid-elevation of the range. The snow pack may not be of uniform depth, being shallower at lower elevations. The line of zero snow depth is known as the snow-line. One of the methods of computing snowmelt in mountain ranges is to establish observation stations for the location of snowline and the areas covered by snow. The snowmelt can be computed by estimating the average elevation of the snowline and assuming the variation of temperature with altitude.

The computations of snowmelt can be made with a more reasonable success by computer simulation and the simulated snowmelt is used as input in the runoff simulation model (Fig. 16.3), to determine the stream flow.

Snow Surveying

In snow surveying, a snow traverse is conducted and sampling points are chosen along a representative snow course. At each sampling point, a tube is driven down through the snow and a snow sample is collected. From this sample, the depth of snow, the water equivalent (the depth of water whose weight is equal to that of the snow pack) and the density of snow can be determined. The density is the percentage of snow volume, which its water equivalent would occupy. Freshly fallen snow has a density of about 10 per cent. As time elapses, it becomes more dense and compact due to coarsening of the crystal structure and settling. The quality of snow is the decimal fraction of its total weight, which is in the form of ice and can be determined by the calorimetric principle. The quality of snow usually varies from 0.95 to 0.70, depending on the rate of melting, the structure of the snow pack and the infiltration capacity of the underlying ground surface, which affects drainage.

A pressure pillow gauge is sometimes used to determine the water equivalent of snow. The pillow is made of thin butyl rubber of diameter ranging from 1.5 to 3.5 m ; larger the size, greater is the accuracy. The pillow is filled with a mixture of water and antifreeze. The internal pressure increases as the snow accumulates on the pillow. The weight of snow is determined by measuring the pressure with a manometer or pressure transducer.

Example A-1 During a snow survey, the data of a snow sample collected are given below:

| | |
|---------------------------|------|
| Depth of snow sample | 2 m |
| Weight of tube and sample | 25 N |

| | |
|-----------------------|-------|
| Weight of sample tube | 20 N |
| Diameter of tube | 40 mm |

Determine

- (i) the density of snow
(ii) the water equivalent of snow
(iii) the quality of snow, if the final temperature is 5 °C when 4 lit. of water at 15 °C is added.

Solution (i) Density of snow is the same as its specific gravity

$$\text{Sp. gr. of snow, } G_s = \frac{\gamma_s}{\gamma_w} = \frac{W_s/V_s}{\gamma_w} = \frac{(25 - 20)/\pi(0.020)^2 \times 2}{1000 \times 9.81} = \mathbf{0.203}$$

$$(ii) \text{ Density of snow, } G_s = \frac{\text{Depth of melt water } (d_w)}{\text{Depth of snow } (d_s)}$$

$$\therefore \text{ Water equivalent of snow, } d_w = G_s d_s = 0.203 \times 2 = \mathbf{0.406 \text{ m}}$$

(iii) If the actual weight of ice content in the sample is W_c gm, then

Heat gained by snow = Heat lost by water

Heat required to melt + to rise temperature to 5 °C

$$W_c \times 80 + \frac{5}{9.81} \times 1000 \times 5 = 4000(15 - 5)$$

$$\text{Solving, } W_c = 468.2 \text{ gm} = 0.4682 \times 9.81 = 4.6 \text{ N}$$

$$\therefore \text{ Quality of snow} = \frac{4.6}{5} = \mathbf{0.92}$$

Example A-2 If the density of a snow pack 1.2 m depth is 20%, determine its weight density, mass density, sp. gr. and water equivalent.

Solution The density is the percentage of snow volume, which its water equivalent would occupy.

$$\therefore \text{ Snow density} = \frac{\text{Depth of melt water } (d_w)}{\text{Depth of snow } (d_s)}$$

$$\therefore 0.20 = \frac{d_w}{d_s}$$

$$\text{Water equivalent of snow, } d_w = 0.20 \times 1.2 = \mathbf{0.24 \text{ m}}$$

$$\begin{aligned} \text{Weight density, } \gamma_s &= \frac{W_s}{V_s} = \frac{W_w}{V_s} = \frac{V_w \gamma_w}{V_s} = \frac{d_w}{d_s} \gamma_w \\ &= 0.20 (1000 \times 9.81) = \mathbf{1962 \text{ N/m}^3} \end{aligned}$$

$$\text{Mass density, } \rho_s = \frac{M_s}{V_s} = \frac{W_s/g}{V_s} = \frac{\gamma_s}{g} = \frac{1962}{9.81} = \mathbf{200 \text{ kg/m}^3}$$

$$\text{Sp. gr., } G_s = \frac{\gamma_s}{\gamma_w} = \frac{1962}{1000 \times 9.81} = \mathbf{0.2}$$

Note, that the specific gravity is the same as the snow density.

Example A-3 The average snow line is at 1400 m elevation and a temperature index station located at 1800 m elevation indicated a mean daily temperature of 8 °C on a certain day. Assuming a temperature decrease of 1 °C per 200 m increase in elevation and a degree-day factor of 3 mm/degree-day, compute the snowmelt runoff for the day. An area elevation curve for the sno pack is shown in Fig. A-2.

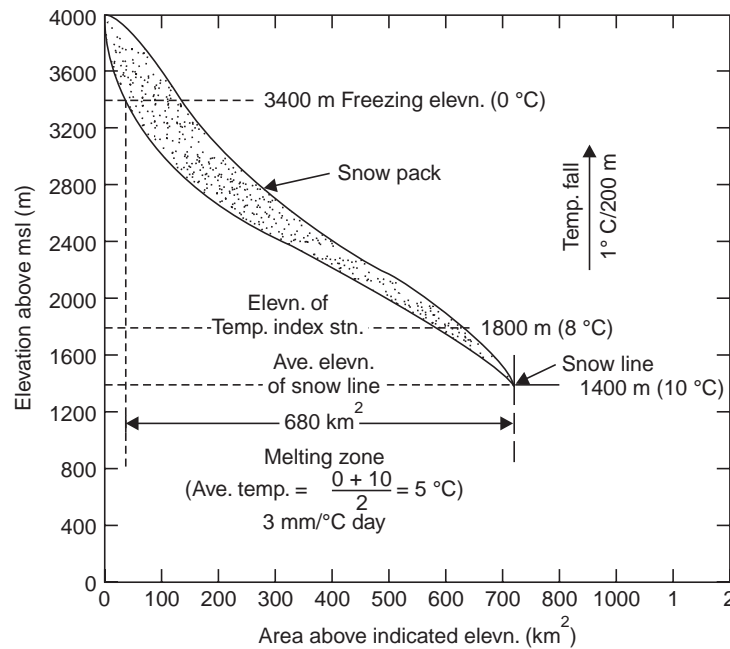

Fig. A-2 Area-elevation curve for snow pack

Solution Freezing occurs at higher altitudes when the temperature falls to 0 °C.

Freezing elevation = $1800 + (8 - 0) \times 200 = 3400$ m. The area between the snow line elevation of 1400 m and the freezing elevation of 3400 m is read out from the area-elevation curve, Fig. A-2 as 680 km². The average temperature over this area is

$$\frac{1}{2} \left[\begin{array}{l} 0^\circ\text{C at} \\ \text{freezing elevn.} \end{array} + \left\{ 8^\circ\text{C} + \frac{1800 - 1400}{200} \right\} \text{ at snow line elevn.} \right]$$

$$= \frac{1}{2} (0 + 10) = 5^\circ\text{C}.$$

Snowmelt runoff for the day

$$= 0.003 \times 5^\circ\text{C} (680 \times 10^6) = 10.2 \times 10^6 \text{ m}^3$$

$$= \mathbf{10.2 \text{ km}^2\text{-m} \text{ or } 1020 \text{ ha-m}}$$

Note: 1 km² = 100 ha.

Assignment Problems

- 1 A snow sample of volume 0.015 m³ weighs 22N and gives a final temperature of 7 °C when mixed with 7 lit. of water at 32 °C. If the depth of snow pack is 0.6 m, calculate the specific gravity, water equivalent, and the quality of snow.

Is the specific gravity same as the snow density? Prove.

$$\left(0.15, 90 \text{ mm}, 0.89, G_s = \frac{d_w}{d_s} \right)$$

- 2 For a certain period in a mountain range, the degree-day factor is $4 \text{ mm}/^\circ\text{C}\text{-day}$. How much the depth of snow pack decreases on a warm spring day with maximum and minimum temperature recorded as 25°C and 7°C , respectively. Assume a sp. gr. of 0.16 for the snow. If the area covered by snow is 450 km^2 , estimate the snowmelt runoff on the day.

Whether this snowmelt and the stream flow observed on the day are concurrent? Explain.

(0.4 m, 28.8 Mm^3)

Appendix B

OVERLAND FLOW

In open-channel hydraulics, overland flow is considered as sheet flow, a spatially varied unsteady flow. Many investigators have made analysis of overland flow and Izzard's method has been found to be more practical.

Laminar Overland Flow

For small plots without defined channels, with short, mild, uniform slopes, such as parking lots, airports, runoff occurs as laminar overland flow for which the critical Reynolds number is given by

$$R_e = \frac{Vd}{\nu} = \frac{q}{\nu} < 1000 \quad \dots(1)$$

where d and q are the uniform depth and discharge per meter width of overland flow, respectively. Izzard has suggested that for rectangular plots, laminar flow occurs if

$$i_{\text{net}} l < 4000 \quad \dots(2)$$

where i_{net} is the net rainfall in mm/hr, and l , b are the length and breadth of the plot in metres. Since $q = i_{\text{net}} l$, Eqs. (1) and (2) in consistent units agree.

Forces under steady, uniform laminar overland flow are shown in Fig. B-1; forces on the element of water $P_1 = P_2$. For steady flow and for $b = 1$

$$\tau(\Delta x \cdot 1) = \Delta W \sin \alpha$$

Putting $\sin \alpha = \tan \alpha = S$

for small values of α , S is the land slope, τ is the shear stress at a depth y above the land surface. Substituting for ΔW ,

$$\tau \Delta x = \Delta x (d - y) \gamma_w S$$

or $\tau = \gamma_w S(d - y)$

Putting $y = 0$, the bed shear $\tau_0 = \gamma_w dS \quad \dots(3)$

From the Newton's law of viscosity,

$$\tau = \mu \frac{dv}{dy}$$

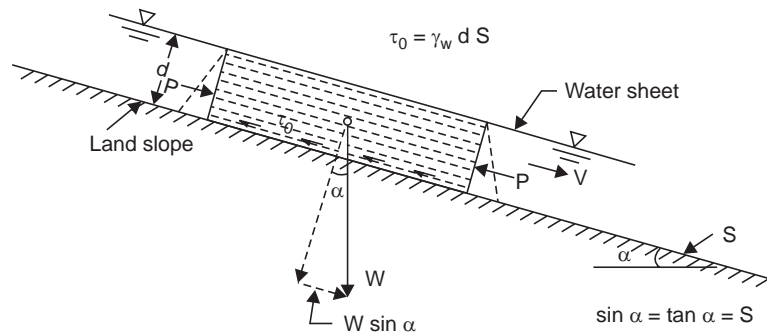

(a) Forces acting on water sheet

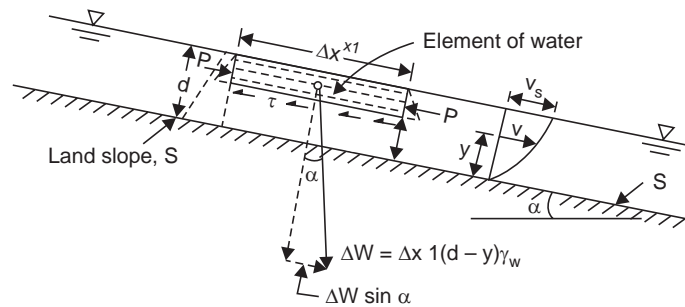

(b) Forces acting on the water element

Fig. B-1 Overland flow analysis

$$\mu \frac{dv}{dy} = \gamma_w S (d - y)$$

$$dv = \frac{\gamma_w S}{\mu} (d - y) dy$$

Integrating both sides,

$$\int dv = \frac{\gamma_w S}{\mu} \int (d - y) dy$$

$$v = \frac{\gamma_w S}{\mu} \left(dy - \frac{y^2}{2} \right) + C$$

At the land surface, $y = 0$, $v = 0$, $\therefore C = 0$.

The velocity at any depth y above the land surface is given by the parabolic equation

$$v = \frac{\gamma_w S}{\mu} \left(dy - \frac{y^2}{2} \right) \quad \dots(4)$$

Mean velocity V is given by

$$V = \frac{1}{d} \int_0^d v dy = \frac{1}{d} \int_0^d \frac{\gamma_w S}{\mu} \left(dy - \frac{y^2}{2} \right) dy, \text{ from Eq. (4)}$$

$$\therefore V = \frac{\gamma_w S}{3\mu} d^2 \quad \dots(5)$$

The discharge, $q = Vd$,

$$q = \frac{\gamma_w S}{3\mu} d^3 \quad \dots(6)$$

Note that $q \sim d^3 S$, so that if q is constant but slope S varies, d and V at another section can be estimated.

The velocity at the water surface v_s is obtained by putting $y = d$ in Eq. (4)

$$v_s = \frac{\gamma_w S}{2\mu} d^2 \quad \dots(7)$$

which is the maximum velocity.

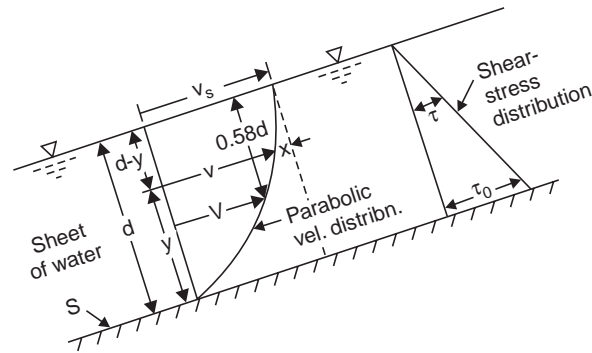

Fig. B-2 Laminar overland flow

From Fig. B-2,

$$v = v_s - x$$

$$\frac{v}{v_s} = 1 - \frac{x}{v_s}$$

$$x = v_s - v$$

$$x = \frac{\gamma_w S}{2\mu} [d^2 - (2dy - y^2)] \quad \text{from Eqs. (4) and (7)}$$

$$\frac{x}{v_s} = \frac{d^2 - 2dy + y^2}{d^2} = \frac{(d-y)^2}{d^2}$$

$$\therefore \frac{v}{v_s} = 1 - \left(\frac{d-y}{d}\right)^2 \quad \dots(8)$$

when $v = V$,
$$\frac{V}{v_s} = 1 - \left(\frac{d-y}{d}\right)^2$$

Since the velocity distribution is parabolic, the mean velocity V is two-thirds of the maximum velocity v_s , *i.e.*, $V = \frac{2}{3} v_s$, or $\frac{V}{v_s} = \frac{2}{3}$

$$\frac{2}{3} = 1 - \left(\frac{d-y}{d}\right)^2 \quad \text{or} \quad \left(\frac{d-y}{d}\right)^2 = \frac{1}{3}$$

$$\therefore d - y = 0.58 d \quad \dots(9)$$

which is in close agreement with the mean velocity position for turbulent stream flow ($\approx 0.6 d$ or mean of the velocities at $0.2 d$ and $0.8 d$).

Turbulent Overland Flow

The equation for the turbulent over land flow can be obtained by using the Manning's equation

$$q = (d \cdot 1)V = (d \cdot 1) \frac{1}{n} R^{2/3} S^{1/2}$$

Since the hydraulic mean radius

$$R \approx d, \text{ for broad surfaces}$$

$$q = \frac{1}{n} d^{5/3} S^{1/2} \quad \dots(10)$$

From Eqs. (6) and (10), for both laminar and turbulent overland flows, from theory and experiments, the equation of flow is of the general form

$$q_e = K d_e^m S^n \quad \dots(11)$$

Where K , m and n are constants varying with the Reynolds number R_e , raindrop impact, and land roughness. For turbulent flow $m = 1.67$, $n = 0.5$ and for laminar flow, $m = 3$, $n = 1$. C.F. Izzard (1946) developed the expression for the laminar overland flow as

$$q_e = K d_e^3 S \quad \dots(12)$$

where $K = \left[\frac{1}{2.8 \times 10^{-5} i + C} \right]^3$

q_e = equilibrium flow in m^3/S per m width of strip at the lower edge of the rectangular area of uniform slope S .

d_e = volume of detention storage, expressed as the average depth over the full length of the strip of unit width, whereas in Eqs. (1) to (10), d is the depth at a particular section where the discharge is q .

i = the actual rainfall intensity in mm/hr, not the net rate, since the term $2.8 \times 10^{-5} i$ is intended to represent the retarding effect of rain-drop impact.

C = a roughness factor depending upon the type of land surface. Experimental values of C reported by Izzard are given below:

| Type of surface | Value of C |
|-----------------------------|------------|
| Concrete pavement | 0.012 |
| Tar and gravel pavement | 0.017 |
| Tar and sand pavement | 0.0075 |
| Smooth asphalt pavement | 0.007 |
| Crushed-slate roofing paper | 0.0082 |
| Dense bluegrass turf | 0.060 |
| Closely clipped sold | 0.046 |

Determination of Overland Flow Hydrograph from Rainfall Data

Eqs. (11) and (12) are for equilibrium flow conditions and will not give correct values for discharge during periods of unsteady flow, which occur during actual storms. Due to time lag

between rainfall and discharge, they give too high values of discharge during the rising stage and too low values during recession time. A simple method is to divide the net-rain hydrograph to a few broad steps, as shown in Fig. B-3 and then draw the discharge hydrograph for each step. The rising hydrograph for the first step is obtained from the empirically derived dimensionless *S*-hydrograph (Fig. B-4). The equilibrium time t_e is taken as the time when the discharge q reaches 97 per cent of the equilibrium discharge q_e and this provides a good keypoint.

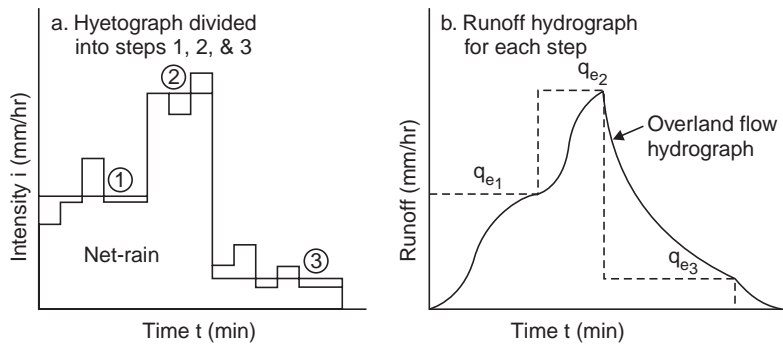

Fig. B-3 Overland flow hydrograph derived from rainfall data

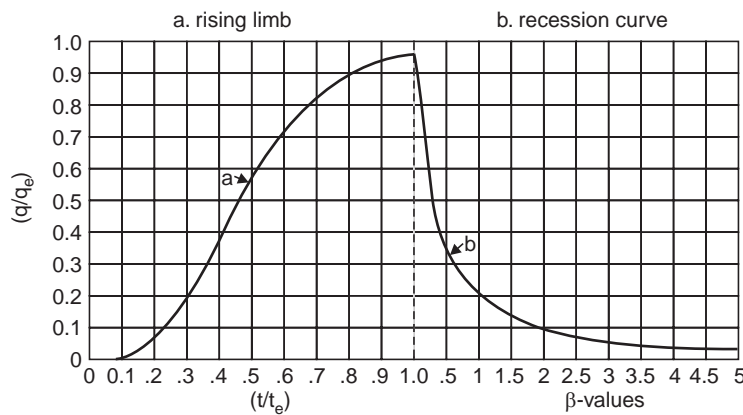

Fig. B-4 Izzard's dimensionless graph (after Izzard, 1946)

Since the *S*-hydrograph divides the graphical plot approximately into two equal parts, the average discharge during the time t_e can be taken as $q_e/2$, which should be equal to the volume divided by the time, *i.e.*,

$$\frac{q_e}{2} = \frac{d_e l}{t_e} \quad \dots(13)$$

from which the equilibrium time t_e can be computed.

Izzard provides techniques for computing the transition hydrographs for higher steps (when water is deeper and faster), shorter steps (when q does not reach q_e) and the recession periods, based on Eq. (12).

The dimensionless recession curve Fig. B-4 defines the shape of the receding limb. At any time t_a after the end of rain, the factor β is given by

$$\beta = \frac{q_e t_a}{d_{e0} l} \quad \dots(14)$$

where in consistent units and $d_{e0} = d_e$ taking $i = 0$.

Example B-1 *Equilibrium overland flow occurs over a rectangular area 100 m long due to a uniform net rainfall of 50 mm/hr. At what distance from the upper edge of the area the flow changes from laminar to turbulent if the temperature is 20 °C and the critical Reynolds number is 800.*

Solution

$$R_e = \frac{vd}{\nu} = \frac{q}{\nu}$$

ν_{water} at 20 °C = 0.01 St = $0.01 \times 10^{-4} \text{ m}^2/\text{S}$ or $1 \times 10^{-6} \text{ m}^2/\text{S}$

$$800 = \frac{q}{1 \times 10^{-6}} \quad \therefore q = 8 \times 10^{-4} \text{ cumec/m}$$

$$q = i_{\text{net}} l, 8 \times 10^{-4} = \frac{50}{1000 \times 60 \times 60} \times l$$

$\therefore l = 57.6 \text{ m}$, beyond which the flow becomes turbulent.

Note: For laminar flow, $i_{\text{net}} l < 4000$ (Izzard)

$$\therefore l < \frac{4000}{50}, \text{ i.e., } l < 80 \text{ m (this assumes critical } R_e = 1000)$$

Example B-2 *A concrete-paved area is 200 m long by 100 m wide and has surface slope of 0.005. The design storm is given by*

$$i = \frac{250}{0.4} \quad (i\text{-mm/hr, } t\text{-min})$$

Construct the outflow hydrograph for a 1-hr storm using Izzard's method.

Solution Equilibrium discharge, $q_e = i_{\text{net}} (l \times 1)$; for $t = 60 \text{ min}$, $i = \frac{250}{60^{0.4}} = 48.5 \text{ mm/hr}$

Assuming $i = i_{\text{net}}$ for the concrete pavement (initially wet),

$$q_e = \frac{48.5}{1000 \times 60 \times 60} (200 \times 1) = 0.0027 \text{ cumec/m}$$

From Eq. (11), $q_e = K d_e^3 S$

$$\text{Depth of flow } d_e = \left[\frac{q_e}{KS} \right]^{1/3}$$

$$K^{1/3} = \frac{1}{(2.8 \times 10^{-5})i + C} = \frac{1}{(2.8 \times 10^{-5})(48.5) + 0.012} = \frac{1}{0.01336}$$

$$\therefore d_e = 0.01336 \left(\frac{0.0027}{0.005} \right)^{1/3} = 0.0131 \text{ m, or } 13.1 \text{ mm}$$

From Eq. (12), the equilibrium time

$$t_e = \frac{2d_e l}{q_e} = \frac{2 \times 0.0131 \times 200}{0.0027} = 1940 \text{ sec} = 32 \text{ min } 20 \text{ sec}$$

Table B-1 To plot the outflow hydrograph using Izzard's dimensionless graph

| <i>Data to plot the rising limb</i> | | | <i>Data to plot the recession curve</i> | | | | |
|-------------------------------------|--|---------|---|-------------|---------------------|----------------------|-----------------------------|
| q/q_e | $Q \times q_e b (\times 0.27) = (m^3/s)$ | t/t_e | $t \times t_e (\times 32.33) = (min)$ | $t_a (min)$ | $\beta = 0.069 t_a$ | q/q_e (from graph) | $(\times 0.27) = Q (m^3/S)$ |
| 0 | 0 | 0 | 0 | 5 | 0.345 | 0.45 | 0.121 |
| 0.2 | 0.054 | 0.31 | 10.0 | 7.5 | 0.517 | 0.30 | 0.081 |
| 0.4 | 0.108 | 0.42 | 13.6 | 10 | 0.690 | 0.27 | 0.073 |
| 0.6 | 0.162 | 0.52 | 16.8 | 15 | 1.035 | 0.18 | 0.049 |
| 0.8 | 0.216 | 0.67 | 21.7 | 20 | 1.38 | 0.13 | 0.035 |
| 0.97 | 0.261 | 1.00 | 32.3 | 25 | 1.72 | 0.11 | 0.030 |
| | | | | 30 | 2.07 | 0.09 | 0.0243 |
| | | | | 40 | 2.76 | 0.06 | 0.0162 |
| | | | | 50 | 3.45 | 0.04 | 0.0108 |
| | | | | 60 | 4.14 | 0.035 | 0.0094 |
| | | | | 65 | 4.50 | 0.03 | 0.0081 |

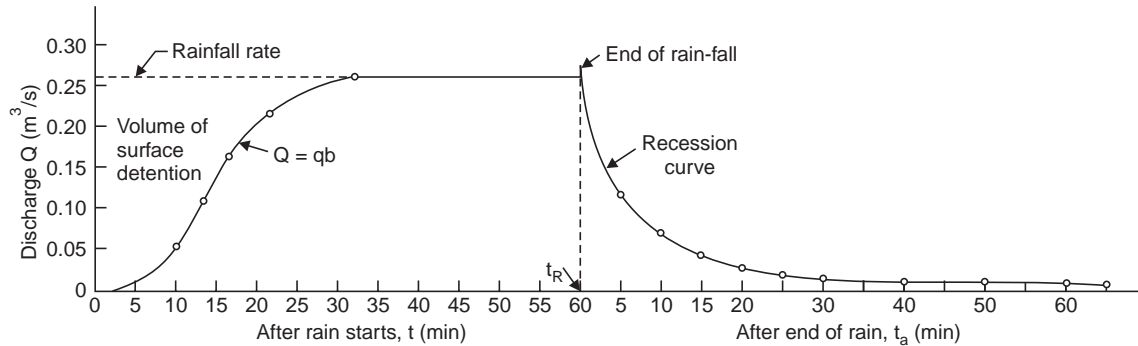

Fig. B-5 Overland flow hydrograph (Example B-2)

Recession factor,

$$\beta = \frac{q_e t_a}{d_{e0} l}, \quad d_{e0} = \left(\frac{q_e}{KS} \right)^{1/3}$$

$$K^{1/3} = \frac{1}{0.012} \quad (\text{with } i = 0)$$

$$d_{e0} = 0.012 \left(\frac{0.0027}{0.005} \right)^{1/3} = 0.01175$$

$$\beta = \frac{0.0027 (t_a \times 60)}{0.01175 \times 200}$$

where t_a = time after the end of rain in min.

$$\therefore \beta = 0.69 t_a$$

From the data in Table B-1, the overland flow hydrograph is constructed as shown in Fig. B-5.

Example B-3 If the depth of surface detention on a smooth surface is 4 mm and the slope is 0.01, determine the wind velocity in the upslope direction required to counterbalance the component of gravity force down slope, if the rainfall rate is 60 mm/hr.

Solution (a) Let the wind velocity be V_w towards upslope (Fig. B-6).

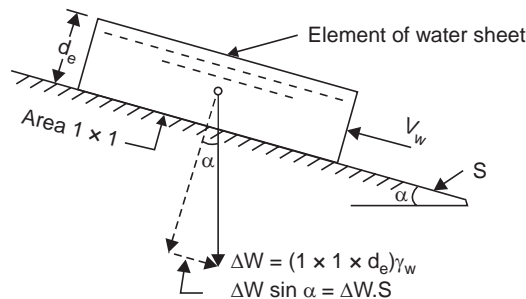

Fig. B-6 Effect of wind on overland flow (Example B-3)

$$Q = iA = \frac{0.060}{60 \times 60} (1 \times 1) = \frac{0.001}{60} \text{ m}^3/\text{S}$$

Force exerted by wind

$$F = \rho Q(\Delta V) = 1000 \times \frac{0.001}{60} V_w = \frac{V_w}{60} N$$

Force downslope due to gravity

$$\begin{aligned} W_s &= \Delta W \sin \alpha = (1 \times 1 \times d_e) \gamma_w \cdot S \\ &= 0.004 (1000 \times 9.81) 0.01 = 0.3924 N \end{aligned}$$

Equating $F = W_s$, velocity of wind

$$V_w = 0.3924 \times 60 = 23.544 \text{ m/s}$$

or

$$\frac{23.544 \times 60 \times 60}{1000} = \mathbf{85 \text{ km/hr}}$$

In the case of moderate slopes, such as airport runway surfaces, wind may play an important part in determining the rate of overland flow.

The raindrop velocity in the direction of wind is equal to the wind speed and the corresponding driving force $F = \rho Q(\Delta V)$ and $Q = iA$. Thus, it is even possible that a considerable portion of the overland flow might be driven up the landslope and over a divide into an adjacent drainage area.

Assignment Problems

- Overland flow of $6 \times 10^{-4} \text{ m}^3/\text{s}$ per metre width occurs over a smooth surface at a temperature of 20°C . Is the flow laminar or turbulent? If the uniform depth is 3 mm, determine the mean velocity, the surface velocity, and the velocity at mid depth.
(Laminar: $R_e = 600, 0.2, 0.3, 0.225 \text{ m/s}$)
- Water is allowed at a steady rate at the upper edge of a sloping surface of constant width and 100 m length. The slope is 0.01 for the first 50 m and 0.05 for the remaining 50 m. If a mean slope for the entire length is assumed, determine the percentage error in the estimation of mean velocity for laminar flow.
- For steady laminar flow along an undulating slope of constant width, if the depth and velocity at one section are 0.3 m/s and 3 mm, respectively, determine the velocity and depth at another section of twice the slope. Determine the Reynolds number for both the sections assuming a temperature of 20°C .
(Hint: $q \sim d^3S, q = dV$) (0.378 m/s, 2.38 mm, 900)
- An area of 4 ha has an average length of overland flow of 60 m on concrete pavement with an average slope of 0.003. The design storm is given by $i = \frac{250}{t^{0.5}}$ where i is in mm/hr and t is in minutes. For a 1-hr storm, find the time of concentration of overland flow. Assuming a flow time of 10 min in the gutter across the slope at lower edge, what is the peak rate of runoff expected?
- Determine the equilibrium time for 50 mm/hr net rainfall on a wet surface of slope 0.01 and length 60 m, if the surface is (a) concrete pavement, and (b) dense bluegrass turf. (14,72 min)
- Comment on the methods of determining peak rate of run-off from (a) small areas, (b) large areas, and (c) areas of all sizes.

Appendix C

RESERVOIR DESIGN STUDIES

The hydrological investigations to be made for the design of a multipurpose reservoir, say for storage, flood control and power generation are given below :

Not only the storage capacity (size) of the reservoir, also the height of dam, crest elevation of the spillway and its length, the sill level of sluices, have to be determined for which

- (i) an estimate for the runoff (yield) at the proposed dam site is required. If the streamflow records at or near the dam site are not available for a number of years, the runoff (yield) have to be obtained from the rainfall data.
- (ii) the hydrograph of MPF (say by the application of PMS over a design unit hydrograph, see Example 8.4) for spillway design and the flood moderating (absorbing) capacity of the reservoir have to be obtained. The peak rate, the volume of flood flow, the time of its occurrence and its duration, all influence the design.

Use of Hydrographs

(i) *Determination of storage capacity* A flow hydrograph for the river at the dam site for a large number of years (25–30 years) has to be obtained (Fig. C-1 (a)) from which a mass curve of inflow can be drawn, (Fig. C-1 (b)) The mass curve of demand is computed from the hydrograph of demand in the same way as mass curve of inflow is computed from the inflow hydrograph, *i.e.*, as cumulative outflow required versus time (months). The demand rate is seldom uniform (as indicated by a straight line in Fig. C-1 (b), and usually varies according to seasons (Fig. C-2).

From an inspection of mass curve in Fig. C-1 (b), *cd* appears to be the driest period on record and *pq* is the volume of storage required to tide over this period. If there are two three dry periods, the maximum departure, among *pq*, is the storage capacity required (to meet the uniform straight line demand). In Fig. C-2, the variable mass curve of demand is superimposed on the mass curve of inflow from the beginning of a severe dry cycle, till the two curves meet again. The ordinate of maximum departure (*mn*) between the two curves is the required storage capacity.

In a reservoir designed primarily for flood control, the capacity of the reservoir does not depend on the pattern of demand to be met during a cycle of dry years but on the maximum flood hydrograph of the river at the dam site and the safe channel capacity down stream.

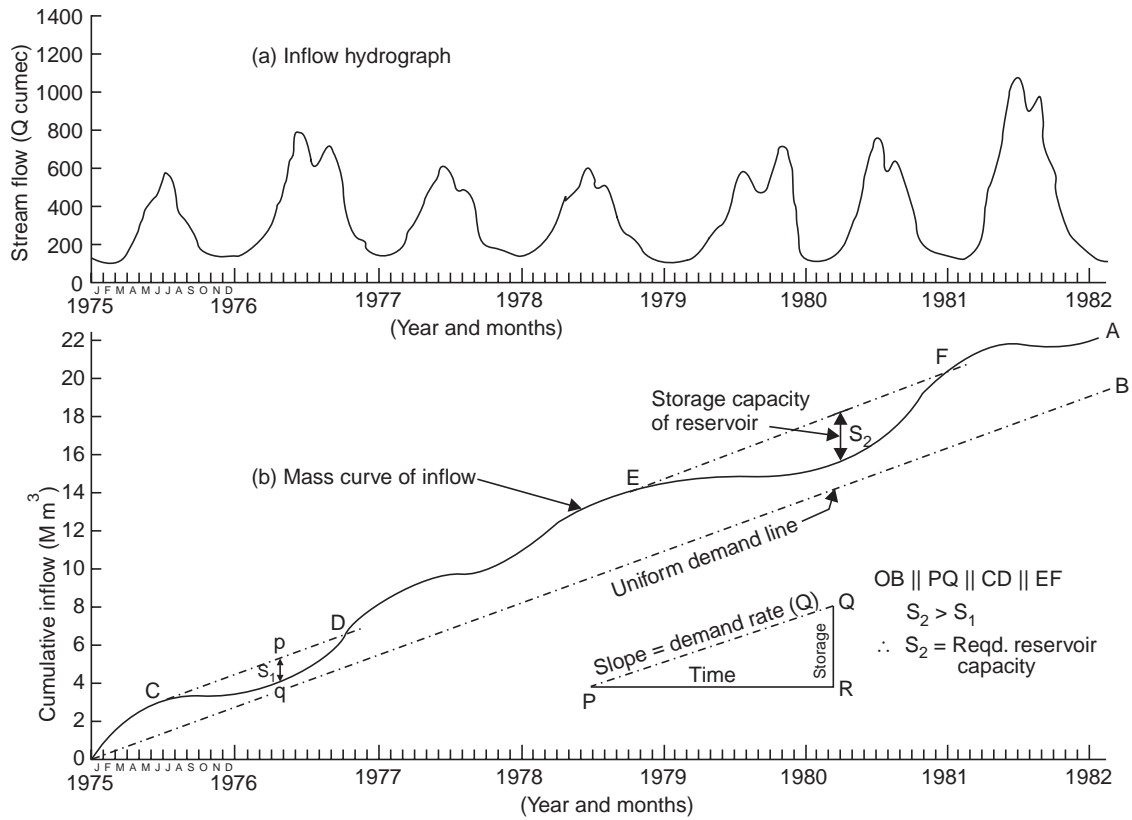

Fig. C-1 Inflow hydrograph and mass curve

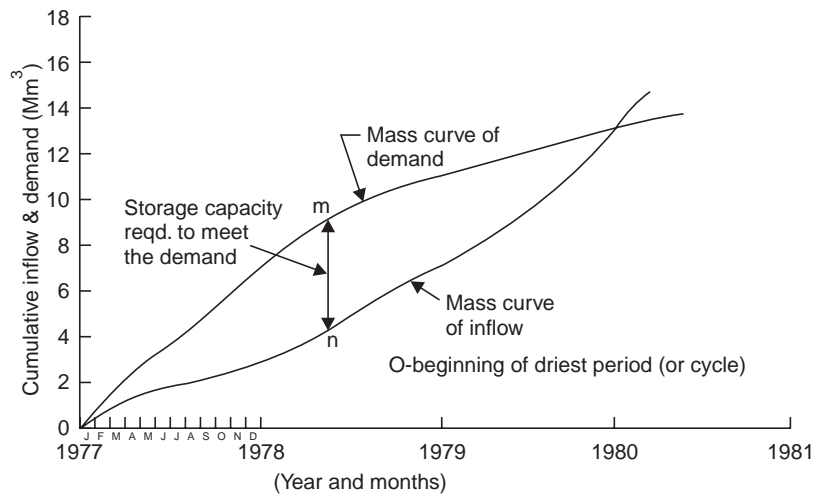

Fig. C-2 Variable demand mass curve

(ii) *Determination of spillway crest level* The principle measures of reservoir economy are

(a) the cost of attaining the given objective/s.

(b) the return on the investment, *i.e.*, on the ratio of benefits to cost (B/C —ratios).

For the objective of flood control, the peak rate of reservoir release (peak of outflow hydrograph) should usually be equal to the maximum safe channel capacity downstream minus a small allowance for local inflow downstream and margin of safety. For the maximum rate of outflow thus established, floods of various magnitudes are routed through the reservoir to determine the storage space required for effective regulation. This is done by trial and involves the capacity curve of the reservoir and discharge curve of the outlets and spillway, *i.e.*, reservoir elevation VS storage capacity and discharge. The costs of providing the various amounts of storage space (by increasing the height of spillway) are compared with the average annual flood-control benefits to be expected (see Table 8.9) in order to determine B/C -ratios. In other words, the inflow hydrograph (of MPF) into the reservoir and the safe peak rate of outflow hydrograph from the reservoir being known (Fig. C-3), the storage space (surcharge storage) required to moderate the former to the safe peak of the latter has to be determined, by trial, for which the B/C ratio is maximum. In Fig. C-3, the peak outflow occurs at the point where the two hydrographs cross, and the storage, and therefore, the hydraulic head, is maximum at this point.

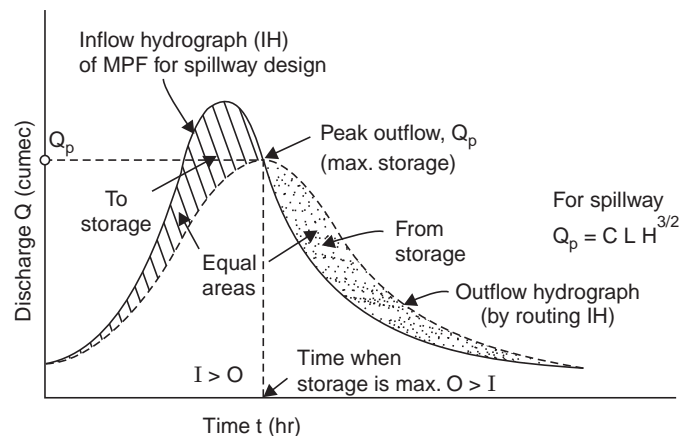

Fig. C-3 Spillway design flood

Allocation of reservoir space For the multipurpose reservoir operation, a space (storage volume) is allocated for each objective. The storage data can be determined from a topographic map of the reservoir site. Cross-sections of the reservoir site are sometimes surveyed and the capacities computed from these vertical cross-sections (area-elevation data) by the use trapezoidal or prismatic formula. The elevation-area and elevation-capacity curves are shown in Fig. C-4.

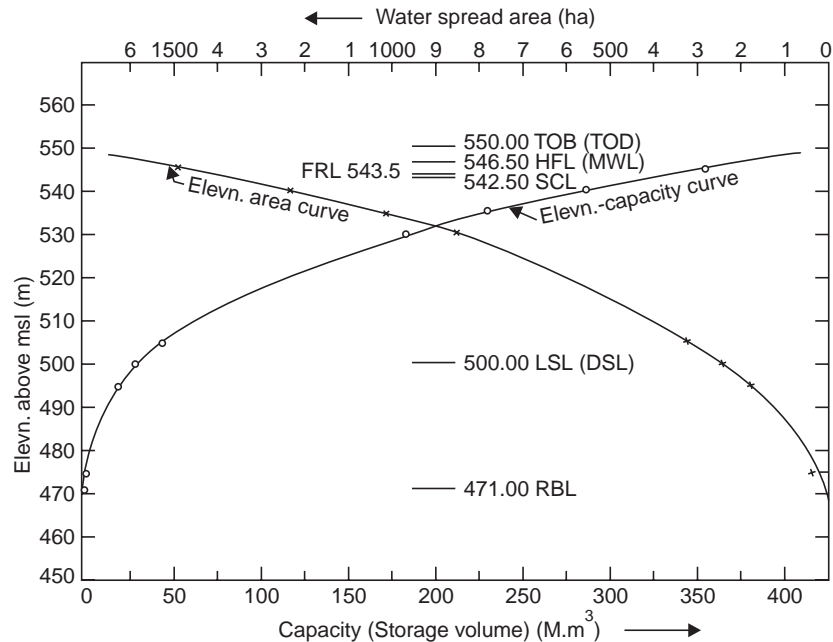

Fig. C-4 Elevation-area-capacity curves for reservoir (Example C-2)

The various control levels in the operation of a multi-purpose reservoir are shown in Fig. C-5. Full reservoir level (FRL) is at the level of the spillway crest or top of the spillway gate. Towards the end of the flood season, the spillway gates are kept closed to store water upto the top of the gate. The spill of the gate is well below the FRL in order to reduce the total length of the spillway (since the head over the crest becomes more) for the passage of the spillway design flood. The low reservoir level (LWL) is at the elevation of the lowest sluice outlet and the water stored below LWL is the dead storage where the silt carried by the stream accumulates and is usually kept at a about 10% of the gross reservoir storage (GS). In the case of hydroelectric projects, the LWL to be maintained is from the point of minimum head required for the operating efficiency of the turbines and to supply firm power (*i.e.*, the power available all the year round ; power available during a part of the year is called *secondary power* and has to be sold at a much lower rate or firmed by thermal installation). The storage volume between the FRL and LWL is called the *useful storage*, which can further be divided into conservation storage and flood control storage, according to the plan of operation of the reservoir. With an adequate flow forecasting system, all or part of the reservoir storage below FRL (say, between FRL and an intermediate reservoir level IRL) can also be made available for flood control and multi-purpose regulation.

During normal flows, the reservoir level will be maintained in the vicinity of FRL and the water will pass through the power conduits. Whenever a flood is forecast, the FRL is drawdown to the extent that the flood runoff will bring the reservoir back to FRL. During low flows, when FRL is reached, the release for power and downstream water requirements will be reduced to minimum.

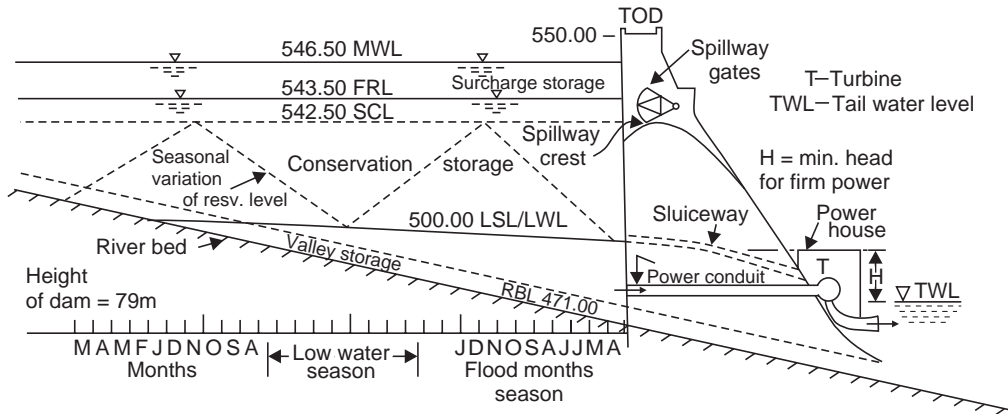

Fig. C-5 Multipurpose reservoir operation (Example C-2)

During high floods, the reservoir level will rise above FRL or well above the spillway crest level. The storage volume between this maximum reservoir level (MWL) and the FRL is called the surcharge storage, which exists only during a flood (where the spillway gates are opened to pass the flood water) and can not be retained for later use. When the floods subside, again the spillway gates are closed to conserve water upto FRL. The spillway has to pass the design flood with the head $H = \text{MWL} - \text{FRL}$.

Water stored during floods in the permeable banks of the reservoir is called 'bank storage' and drains out when the water level is lowered. The water stored in a natural stream-channel is called 'valley storage' and is a variable volume. From the point of flood control, the effective storage in the reservoir = useful storage + surcharge storage – natural valley storage.

In the case of shallow and narrow rivers, the velocity will be high ; the water surface during high flows may be steep (with considerable amount of wedge storage) and the water surface profile (back water curve) can be computed by the non-uniform flow equation (for a given inflow rate and the reservoir elevation at the dam). From this the information regarding the water surface levels at various points along the stream, submergence of lands, roads, bridges, and other strategic structures for which compensation has to be paid, the acquisition of lands, etc., can be obtained.

Example C-1 (a) The runoff data for a river during a lean year along with the probable demands are given below. Can the demands be met with the available river flow ? If so, how ?

(b) What is the maximum uniform demand that can be met and what is the storage capacity required to meet this demand ?

| Month : | J | F | M | A | M | J | J | A | S | O | N | D |
|---------------------------------|-----|----|----|-----|-----|-----|-----|-----|-----|----|----|----|
| River flow (Mm^3) | 135 | 23 | 27 | 21 | 15 | 40 | 120 | 185 | 112 | 87 | 63 | 42 |
| Demand (Mm^3) | 60 | 55 | 80 | 102 | 100 | 121 | 38 | 30 | 25 | 59 | 85 | 75 |

Solution (a) Evaporation losses and the prior water rights of the downstream user are not given and hence not considered. The computation is made in Table C-1. Since the cumulative surplus is more than the cumulative deficit the demands can be met with the available river flows, by constructing a reservoir with minimum storage capacity of 352 Mm^3 , which is also

the maximum departure of the mass curves (from the beginning of the severe dry period) of inflow and demand, Fig. C-6.

Table C-1 Reservoir storage for the variable demand. (Example C-1)

| Month | Inflow (Mm ³) | Cumulative inflow (Mm ³) | Demand (Mm ³) | Cumulative demand (Mm ³) | Surplus (Mm ³) | Cumulative surplus (Mm ³) | Deficit (Mm ³) | Cumulative deficit (Mm ³) | Remarks |
|-------|---------------------------|--------------------------------------|---------------------------|--------------------------------------|----------------------------|---------------------------------------|----------------------------|---------------------------------------|---------------------------------|
| Jan. | 135 | (870) | 60 | (830) | 75 | 75 | | | (Reservoir full by end of Jan). |
| Feb. | 23 | 23 | 55 | 55 | | | 32 | | (Start of dry period) |
| March | 27 | 50 | 80 | 135 | | | 53 | | |
| April | 21 | 71 | 102 | 237 | | | 81 | | |
| May | 15 | 86 | 100 | 337 | | | 85 | | |
| June | 40 | 126 | 121 | 458 | | | 81 | 332 | (Max. draft = storage) |
| July | 120 | 246 | 38 | 496 | 82 | | | | |
| Aug. | 185 | 431 | 30 | 526 | 155 | | | | |
| Sept. | 112 | 543 | 25 | 551 | 87 | | | | |
| Oct. | 87 | 630 | 59 | 610 | 28 | 352 | | | |
| Nov. | 63 | 693 | 85 | 695 | | | 22 | | |
| Dec. | 42 | 735 | 75 | 770 | | | 33 | 55 | |
| Total | 870 | | | | | 427 | | 387 | |

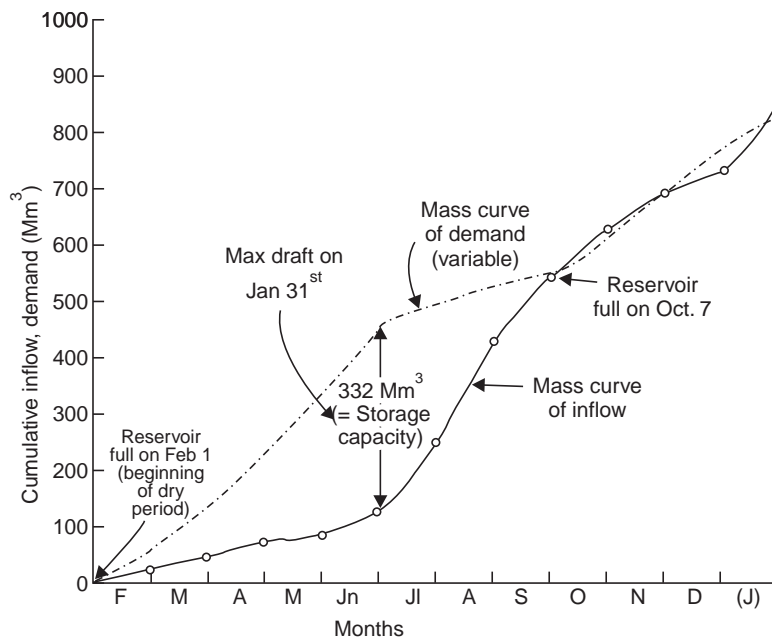

Fig. C-6 Mass curves for storage capacity (Example C-1)

In the bar graph (Fig. C-7), the monthly inflow and demand are shown by full line and dashed line, respectively. The area of maximum deficit (*i.e.*, demand over surplus) is the storage capacity required and is equal to 332 Mm³.

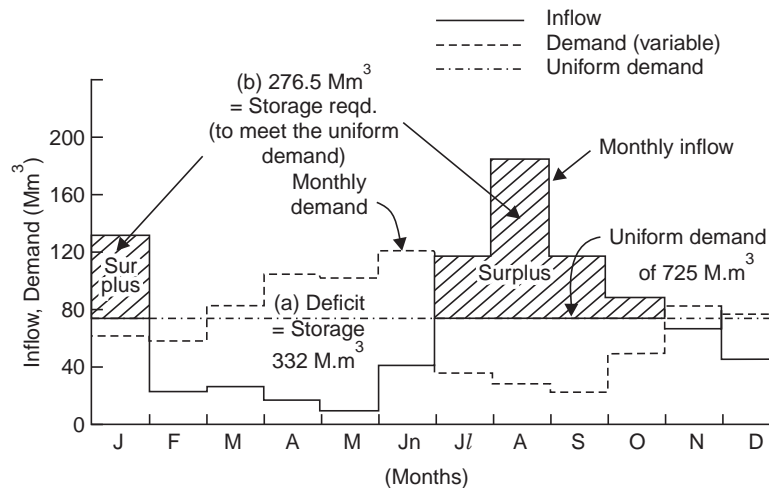

Fig. C-7 Bar-graph for storage capacity (Example C-1)

(b) The cumulative inflow in the lean year is 870 Mm³. The maximum uniform demand that can be met is $\frac{870}{12} = 72.5 \text{ Mm}^3$ per month. In the bar graph (Fig. C-7), the line of uniform demand is drawn at 72.5 M.m³/month. The shaded area represents the surplus over the uniform demand (during the months of January, and July to October), which is the storage capacity required to meet the uniform demand, and is equal to

$$(135) + (120 + 185 + 112 + 87) - 72.5 \times 5 = \mathbf{276.5 \text{ Mm}^3}$$

Example C-2 The following are the data for a proposed medium size reservoir in Maharashtra. Determine LSL, FRL, HFL (MWL). What is the total length of the spillway fitted with crest gates assuming a pier width of 1.5 m (10 m span), flood detention of 4 hr and $C = 2.2$.

| | |
|-------------------------------|----------------------|
| Catchment area | 1200 km ² |
| Rainfall of 75% dependability | 900 mm |
| Gross commanded area | 25000 ha |

Crpping pattern (proposed) and their water requirement (Δ)

- (i) Kharif : Jowar—30% (0.45 m), Cotton—15% (0.75 m),
Rice—10% (1.20 m), Sugar cane—10% (1.90 m)
- (ii) Rabi: Rice—20% (1.20 m), Wheat—20% (0.45 m)
- (iii) Hot Weather: Vegetables—20% (0.60 m)

Area Capacity of Reservoir Site

| | | | | | |
|-----------------------------|-----|------|-------|-------|-------|
| Contour RL (m) | 471 | 475 | 495 | 500 | 505 |
| Area (ha) | 0 | 36 | 178 | 242 | 323 |
| Capacity (Mm ³) | 0 | 0.90 | 19.35 | 29.85 | 43.98 |

| | | | | |
|--|--|--------|--------|--------|
| <i>Contour RL (m)</i> | 530 | 535 | 540 | 545 |
| <i>Area (ha)</i> | 841 | 1002 | 1224 | 1480 |
| <i>Capacity (Mm³)</i> | 186.62 | 232.69 | 288.34 | 355.95 |
| <i>River bed level</i> | 471.0 | | | |
| <i>Top of bund level (TBL)</i> | 550.0 | | | |
| <i>Silt load (expected)</i> | 250 m ³ /km ² /yr with a life of 100-yr. | | | |
| <i>Evaporation losses</i> | 1.5 m over the mean area | | | |
| <i>Empirical formula for yield and flood of the region</i> | Inglis formula. | | | |

Solution (a) Yield from the basin :

$$\text{Dependable runoff } R = \frac{(P - 17.8)P}{254} \quad \text{Inglis formula}$$

$$P = 95 \text{ cm}, R = \frac{(90 - 17.8)90}{254} = 25.6 \text{ cm}$$

$$\begin{aligned} \text{Yield} = AR &= 1200 \times 10^6 (0.256) = 307.2 \times 10^6 \text{ m}^3 \\ &= 307 \text{ Mm}^3. \end{aligned}$$

(b) Irrigation water requirement:

| | |
|-------------------|---------------------------------|
| (i) Kharif: Jowar | 25000 × 0.3 × 0.45 = 3380 ha-m |
| Cotton | 25000 × 0.15 × 0.75 = 2820 ha-m |
| Rice | 25000 × 0.10 × 1.20 = 3000 ha-m |
| Sugarcane | 25000 × 0.10 × 1.90 = 4750 ha-m |
| | 13950 ha-m |
| (ii) Rabi: Rice | 25000 × 0.20 × 1.20 = 6000 ha-m |
| Wheat | 25000 × 0.20 × 0.45 = 2250 ha-m |
| | 8250 ha-m |

(iii) Hot weather:

| | |
|------------|---------------------------------|
| Vegetables | 25000 × 0.20 × 0.60 = 3000 ha-m |
|------------|---------------------------------|

Total for the three crop seasons = 25200 ha-m.

Allowing 20% for conveyance losses, 10% for evaporation and seepage losses in the reservoir, 5% for overlap, and 5% as carryover storage—a total of 40%.

$$\text{Live storage} = 25200 \times 1.40 = 35280 \text{ ha-m or } = 352.8 \text{ Mm}^3$$

While the annual yield is only 307 Mm³ which limits the area irrigated unless supplemented by natural rainfall. Hence, a live storage of 307 M.m³ is possible. Curves of elevn. vs. capacity and elevn. vs. water spread area are shown in Fig. C-4.

$$\text{Dead storage} = 250 \times 1200 \times 100 = 30 \times 10^6 \text{ m}^3 \text{ or } 30 \text{ Mm}^3$$

for which from the elevn-capacity curve, the lowest sill level of the sluice, LSL = **500.00 m**

$$\text{Gross storage} = \text{Dead storage} + \text{Live storage} = 30 + 307 = 337 \text{ Mm}^3$$

for which from the elevn-capacity curve, the full reservoir level

$$\text{FRL} = \mathbf{543.50 \text{ m}}$$

Allowing a flood lift of 3 m, the maximum water level (MWL) or

$$\text{HFL} = 546.50 \text{ m}$$

With a freeboard of 3.5 m, top of bound level or top of dam, TBL or

$$\text{TOD} = 550.00 \text{ m}$$

$$\text{Height of dam} = \text{TOD} - \text{RBL} = 550.00 - 471.00 = 79 \text{ m}$$

Length of spillway

Assuming the crest of the spillway is at FRL, the head on the spillway.

$$\text{HFL} - \text{FRL} = 546.5 - 543.5 = 3 \text{ m}$$

Effective length of spillway per span

$$\begin{aligned} L_e &= L - 0.1 nH \\ &= 10 - 0.1 \times 2 \times 3 = 9.4 \text{ m} \end{aligned}$$

Discharge over spillway per span

$$\begin{aligned} q &= CL_e H^{3/2} \\ &= 2.2 \times 9.4 \times 3^{3/2} = 108 \text{ cumec/span} \end{aligned}$$

Flood absorbing capacity

$$\begin{aligned} \text{FAC} &= \text{Capacity at HFL} - \text{capacity at FRL} \\ &= 374 - 337 = 37 \text{ Mm}^3 \end{aligned}$$

$$\text{Spillway design flood, } Q_D = \text{MPF} - \frac{\text{FAC}}{T}$$

where T = flood detention time in the reservoir and usually varies between $2\frac{1}{2}$ to 16 hr, and here given as $T = 4$ hr. The maximum flood discharge (MPF) may be calculated from the **Inglis formula** applicable for the region.

$$\begin{aligned} \text{MPF} &\approx \frac{124 A}{\sqrt{A + 10.24}} \\ &\approx \frac{124 \times 1200}{\sqrt{1200 + 10.24}} \\ &\approx 4280 \text{ cumec} \end{aligned}$$

$$\therefore Q_D = 4280 - \frac{37 \times 10^6}{4 \times 60 \times 60} = 1710 \text{ cumec}$$

$$\therefore \text{No. of spans required} = \frac{1710}{108} = 15.8, \text{ say, } 16.$$

$$\begin{aligned} \text{Total length of spillway} &= 16 \times 10 + 1.5 \times 15 \\ &\quad \text{spans} \quad \text{piers} \\ &= 182.5 \text{ m} \end{aligned}$$

This length of the spillway can be reduced if the spillway crest (*i.e.*, the sill of the crest gates) is kept at R.L. 542.50 m, so that the crest gates (height = 4 m) conserve water upto R.L. 543.50 m (FRL) or even above this level, as the floods subside (*i.e.*, towards the end of flood season).

$$H = 546.5 - 542.5 = 4 \text{ m}$$

$$q = 2.2 \times 9.4 \times 4^{3/2} = 165.5 \text{ cumec/span}$$

$$\text{FAC} = 374 - 322.5 = 51.5 \text{ M.m}^3$$

(since when the floods are forecast, the FRL is lowered to the spillway crest level by opening the crest gates)

$$Q_D = 4280 - \frac{51.5 \times 10^6}{4 \times 60 \times 60} = 700 \text{ cumec}$$

$$\text{No. of spans required} = \frac{700}{165.5} = 4.23, \text{ say } 5 \text{ spans}$$

$$\text{Total length of spillway} = 5 \times 10 + 1.5 \times 4 = 56 \text{ m}$$

The various control levels are shown in Fig. C-5.

The flood absorption capacity thus reduces the peak of the MPF. Actually the MPF hydrograph into the reservoir (inflow hydrograph) is first obtained and then routed (for an assumed elevn of spillway crest, RL of sluice outlets) by making use of elevn-capacity-discharge relationship, and the peak of the outflow hydrograph thus derived gives the spillway design flood. For small reservoirs (catchment area < 100 km²) the flood absorbing capacity is neglected as additional safety factor.

Assignment Problem

For the peak of the outflow hydrograph obtained by routing (by modified Puls method) the hydrograph of inflow into the reservoir in Example 9.1, determine the length of spillway assuming $C = 2.2$ (**Note:** Max. pool elevn. reached = 113.6 m, and elevn. of spillway crest = 112.3 m).

Appendix D

UNSTEADY GROUNDWATER FLOW

When a well in an extensive confined aquifer is pumped at a constant rate, water is released from storage within the aquifer due to decompression as the piezometric head is reduced and the radius of influence increases, with respect to time. Assuming that the velocity of flow in the aquifer as horizontal, the differential equation in polar coordinates can be written as

$$\frac{\partial^2 h}{\partial r^2} + \frac{1}{r} \frac{\partial h}{\partial r} = \frac{S}{T} \frac{\partial h}{\partial t} \quad \dots(1)$$

Using the analogy of the above equation to heat conduction, Theis (1935) obtained the following solution by assuming that $h = H$ at $t = 0$, and after pumping (at a constant rate Q) starts, $h \rightarrow H$ as $r \rightarrow \infty$. The drawdowns at any distance r from the pumping well is given by

$$s = H - h = \frac{Q}{4\pi T} \int_u^\infty \frac{e^{-u}}{u} du \quad \dots(2)$$

or,

$$s = \frac{Q}{4\pi T} W(u) \quad \dots(3)$$

and,

$$u = \frac{r^2 S}{4Tt} \quad \dots(4)$$

$W(u)$ is called the *well function* and u is called the *argument of the well function*; T and S are the aquifer constants called the *transmissibility and storage coefficients*. The solution of Eq. (2) is

$$s = \frac{Q}{4\pi T} \left[-0.577216 - \ln u + u - \frac{u^2}{2.2!} + \frac{u^3}{3.3!} - \frac{u^4}{4.4!} + \dots \right] \quad \dots(5)$$

The convergent series in brackets is the well function $W(u)$. Both u and $W(u)$ are dimensionless and the plot of $W(u)$ vs. u on log-log paper is called the 'Theis Type Curve' (Fig. D-1). The values of $W(u)$ for different values of u are given in Tables (Ferris et al., 1962). Since $W(u)$ and u are both functions of T and S , Eqs. (3) and (4) can not be solved directly and special procedures are employed.

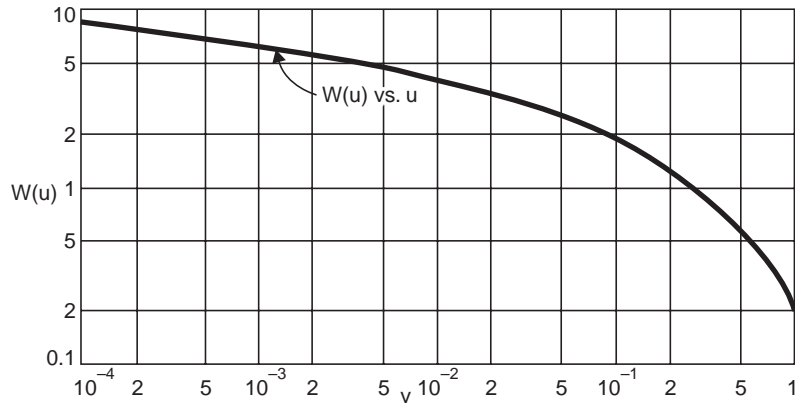

Fig. D-1 Theis Type-curve for the well function

(a) **Theis' Graphical Procedure (Theis 1935, Lohman, 1972)**

Taking logarithms of Eq. (3),

$$\log s = \log \frac{Q}{4\pi T} + \log W(u) \quad \dots(6)$$

From Eq. (4),

$$\frac{r^2}{t} = \frac{4Tu}{S} \quad \dots(7)$$

and taking logarithms of Eq. (7),

$$\log \frac{r^2}{t} = \log \frac{4T}{S} + \log u \quad \dots(8)$$

Since $\frac{Q}{4\pi T}$ and $\frac{4T}{S}$ are constants for a particular pumping test, the Eqs. (6) and (8) are

similar. If the field pump-test curve 's vs. $\frac{r^2}{t}$ ' and the 'type curve' ' $W(u)$ ' vs. u are drawn to the same scale on log-log paper on separate transparent sheets and superimposed with the coordinate axes parallel, so that the two curves coincide for some length AB , an arbitrary match point P is selected, Fig. D-2, and its coordinates are read on both the graphs. From the

match-point coordinates, s , $\frac{r^2}{t}$, $W(u)$, and u , the aquifer constants can be calculated from Eqs.

(3) and (4).

(b) **Cooper-Jacob Solution (Modified Theis)**

From Eq. (4), it is evident that ' u ' decreases as the pumping time t increases. Jacob (1946, 1950) pointed out that for large values of t and small values of r , u becomes small enough so that in the convergent series, Eq. (5), the terms after the first two become negligible. Thus, the drawdown can be expressed as,

$$s = \frac{Q}{4\pi T} \left(-0.577216 - \ln \frac{r^2 S}{4Tt} \right)$$

after changing into logarithm to base 10 and simplifying

$$s = \frac{2.3Q}{4\pi T} \log \frac{2.25 Tt}{r^2 S}, \quad u < 0.01 \quad \dots(9)$$

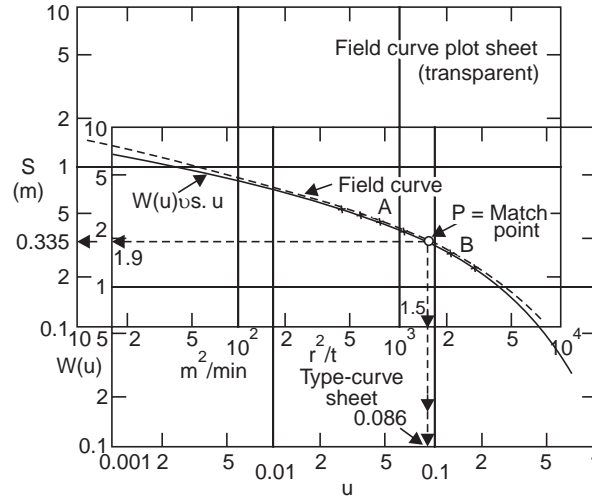

Fig. D-2 Match-point coordinates (Theis)

Hence, a plot of s vs. t on a semi-log paper gives a straight line (Fig. D-3). If the drawdown difference per log-cycle of time is Δs , then T can be determined from

$$\Delta s = \frac{2.3Q}{4\pi T} \quad \dots(10)$$

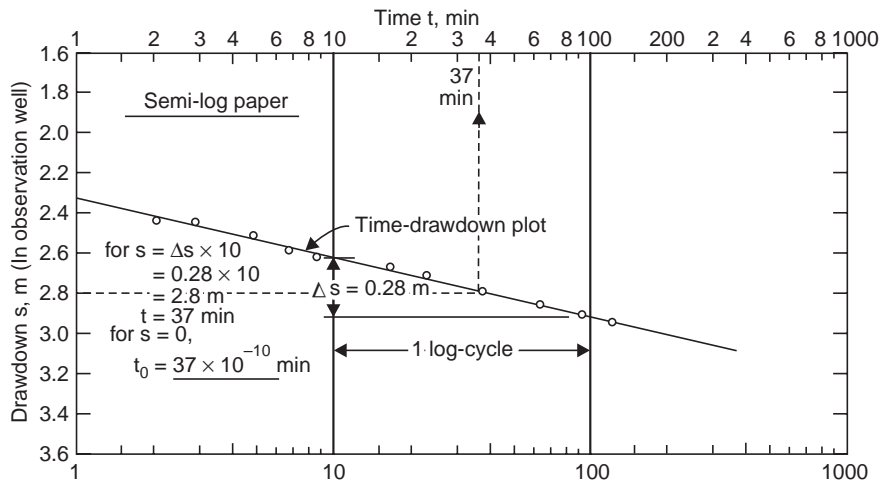

Fig. D-3 Time-drawdown plot (Example D-1)

From Eq. (9), since $s = 0$ when $\frac{2.25 T t}{r^2 S} = 1$

$$S = \frac{2.25 T t_0}{r^2} \quad \dots(11)$$

in which t_0 is the time for $s = 0$, obtained from the semi-log plot by extending the straight line to meet the line of zero-drawdown. Thus, the aquifer constants T and S can be determined from the time drawdown data obtained from a pumping test, on a single well. If there are

several observation wells, by knowing their drawdown after pumping for a certain time t , the aquifer constants T and S can be determined by a plot of a distance-drawdown on a semi-log paper (Fig. D-4). From Eq. (9),

$$s = \frac{2.3Q}{4\pi T} \log \left(\frac{r_1}{r_2} \right)^2$$

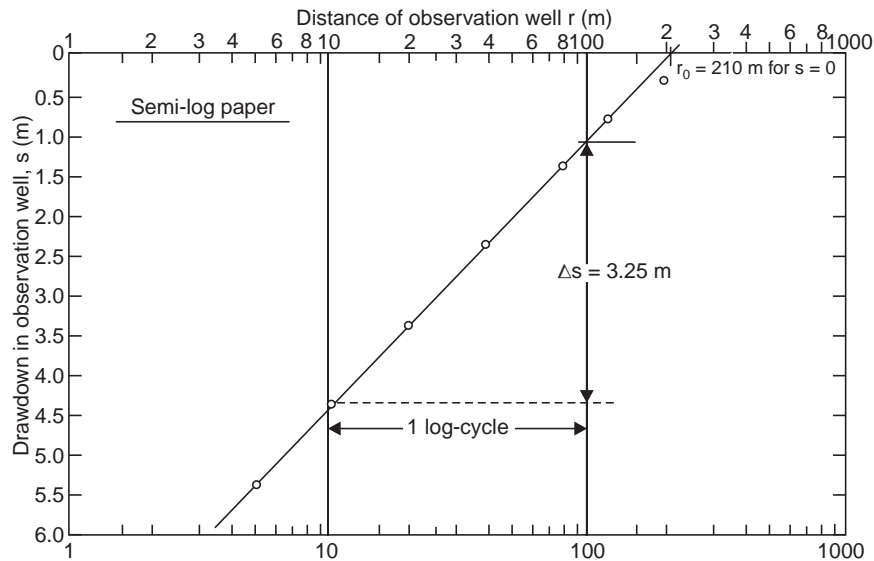

Fig. D-4 Distance drawdown plot (Example D-2)

If the drawdown difference per log-cycle of r is Δs , then T can be determined from

Eq.(10):
$$\Delta s = \frac{2.3Q}{4\pi T} \dots(12)$$

and S from

Eq.(11):
$$S = \frac{2.25 Tt}{r_0^2} \dots(13)$$

where r_0 is the distance for $s = 0$ obtained by extending the straight line plot to meet the line of zero drawdown.

(c) **Theis' Recovery Method**

If a well is pumped for a time t_1 (when the drawdown is s_1) and then stopped, the drawdown goes on decreasing. The residual drawdown s' , at time t' since pumping stopped, or t since pumping started ($t = t_1 + t'$), is equal to the drawdown (s) due to continuous pumping upto t , minus increase in head (s_r) due to an equal recharging well since pumping stopped (Fig. D-5), i.e.,

$$s' = s - s_r \dots(14)$$

For small r and large t' ,

$$s' = \frac{2.3Q}{4\pi T} \log \frac{t}{t'}, \quad u < 0.01 \dots(15)$$

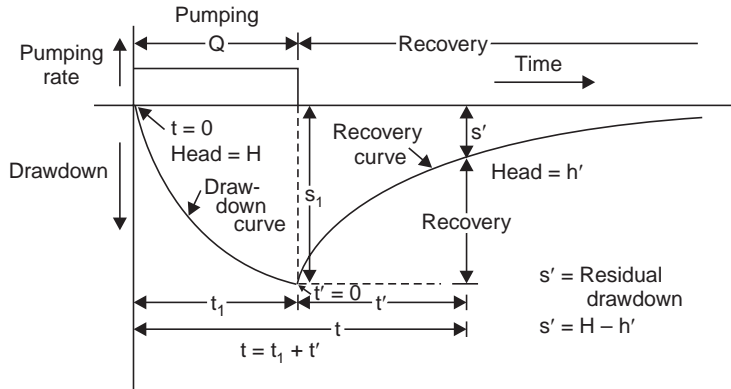

Fig. D-5 Theis' recovery method

A plot of ' s' vs. $\frac{t}{t'}$ ', on a semi-log paper gives a straight line plot (Fig. D-6), and if $\Delta s'$ is the difference in s' per log-cycle of $\frac{t}{t'}$, then T can be determined from

$$\Delta s' = \frac{2.3Q}{4\pi T} \quad \dots(16)$$

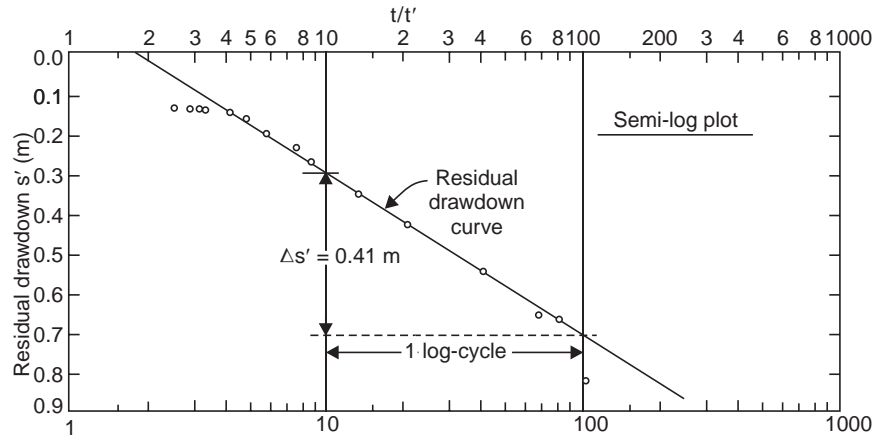

Fig. D-6 Theis recovery curve (Example D-3)

and this value of T can be used as a check on T determined from the drawdown data during pumping; S can be determined from the value of s_1 when pumping stopped, using Eq. (9), as

$$s_1 = \frac{2.3Q}{4\pi T} \log \frac{2.25 T t_1}{r^2 S} \quad \dots(17)$$

In all the above methods, the assumptions made (in addition to those given under steady groundwater flow in Chapter—7) are :

- (i) The water comes from storage and is instantaneously released with reduction of head.
- (ii) The diameter of the pumped well is small, *i.e.*, storage in the well can be neglected. Fairly long time predictions of drawdown (assuming no recharge) can be made from T and S , by the methods of Theis, modified Theis (Jacob, Chow) and other investigators.

Example D-1 A 200 mm-well is pumped at the rate 1150 lpm. The drawdown data on an observation well 12.3 away from the pumped well are given below. Determine the transmissibility and storage coefficients of the equifer. What will be the drawdown at the end of 180 days (a) in the observation well, (b) in the pumped well ? Use the modified Theis method ; under what conditions is this method valid ?

| | | | | | | |
|---------------|------|------|------|------|------|------|
| Time (min): | 2 | 3 | 5 | 7 | 9 | 12 |
| Drawdown (m): | 2.42 | 2.46 | 2.52 | 2.58 | 2.61 | 2.63 |
| Time (min): | 15 | 20 | 40 | 60 | 90 | 120 |
| Drawdown (m): | 2.67 | 2.71 | 2.79 | 2.85 | 2.91 | 2.94 |

Solution The time-drawdown plot is shown in Fig. D-3, from which $\Delta s = 0.28$ m per log-cycle of t , and t_0 (for $s = 0$) is 37×10^{-10} min.

$$\therefore T = \frac{2.3Q}{4\pi\Delta s} = \frac{2.3 \times 1150/60}{4\pi(0.28)} = 0.0125 \text{ m}^2/\text{s}$$

or 10.8×10^5 lpd/m

$$S = \frac{2.25 T t_0}{r^2} = \frac{2.25 (0.0125) 37 \times 10^{-10} \times 60}{(12.3)^2} = 4.12 \times 10^{-11}$$

(a) Drawdown in the observation well after 180 days,

$$s = \frac{2.3Q}{4\pi T} \log \frac{2.25 T t}{r^2 S}, \quad u < 0.01$$

$$s = \frac{2.3(1150/60)}{4\pi(0.0125)} \log \frac{2.25 (0.0125) 180 \times 86400}{(12.3)^2 4.12 \times 10^{-11}} = 3.89 \text{ m}$$

(b) Drawdown in the pumped well after 180 days

$$s_w = \frac{2.3(1150/60)}{4\pi(0.0125)} \log \frac{2.25 (0.0125) 180 \times 86400}{(0.100)^2 4.2 \times 10^{-11}} = 5.06 \text{ m.}$$

The Jacob's method is valid for

$$u < 0.01$$

$$\frac{r^2 S}{4Tt} < 0.01$$

or

$$t > \frac{r^2 S}{0.04T} > \frac{(12.3)^2 4.12 \times 10^{-11}}{0.04 (0.0125)} > 1.25 \times 10^{-5} \text{ sec}$$

i.e., instantaneously after pumping starts.

Example D-2 A production well was pumped for 2 hr at a constant rate of 1600 lpm and the drawdowns in the seven nearby observation wells are given below. Determine the aquifer constants S and T .

| | | | | | | | |
|-------------------------------|------|------|------|------|-----|-----|-----|
| Observation well | A | B | C | D | E | F | G |
| Distance from pumped well (m) | 5 | 10 | 20 | 40 | 80 | 120 | 200 |
| Drawdown (m) | 5.35 | 4.35 | 3.35 | 2.35 | 1.4 | 0.8 | 0.3 |

Solution The distance-drawdown plot is shown in Fig. D-4 from which $\Delta s = 3.25$ m per log-cycle of r , and r_0 (for $s = 0$) is 210 m.

$$T = \frac{2.3 Q}{2\pi\Delta s} = \frac{2.3(1600/60)}{2\pi(3.25)} = \mathbf{0.003 \text{ m}^2/\text{s} \text{ for } 2.6 \times 10^6 \text{ lpd/m}}$$

$$S = \frac{2.25Tt}{r_0^2} = \frac{2.25(0.03)2 \times 60 \times 60}{210^2} = \mathbf{0.0011}$$

Example D-3 A 400-mm well was pumped at the rate of 2000 lpm for 200 min and the drawdown in an observation well 20 m from the pumping well was 1.51 m. The pumping was stopped and the residual drawdowns during recovery in the observation well for 2 hr are given below. Determine the aquifer constants S and T .

| <i>Time since pumping stopped (min)</i> | <i>Residual drawdown (m)</i> | <i>Time since pumping stopped (min)</i> | <i>Residual drawdown (m)</i> |
|---|--------------------------------------|---|--------------------------------------|
| 2 | 0.826 | 45 | 0.180 |
| 3 | 0.664 | 50 | 0.159 |
| 5 | 0.549 | 55 | 0.155 |
| 10 | 0.427 | 60 | 0.149 |
| 16 | 0.351 | 70 | 0.146 |
| 20 | 0.305 | 80 | 0.140 |
| 25 | 0.271 | 90 | 0.134 |
| 30 | 0.241 | 100 | 0.131 |
| 35 | 0.220 | 110 | 0.131 |
| 40 | 0.201 | 120 | 0.131 |

Solution The time-residual drawdown data are processed in Table D-1 and the Theis recovery curve is plotted on a semi-log paper as shown in Fig. D-6.

Table D-1 Theis recovery method, $t_1 = 200$ min.

| <i>Time since pumping stopped t' (min)</i> | <i>Residual drawdown s' (m)</i> | <i>Time since pumping started $t = t_1 + t'$ (min)</i> | <i>Ratio (t/t')</i> |
|---|--|---|--------------------------------------|
| 2 | 0.826 | 202 | 101 |
| 3 | 0.664 | 203 | 68 |
| 5 | 0.549 | 205 | 41 |
| 10 | 0.427 | 210 | 21 |
| 16 | 0.351 | 216 | 13.5 |
| 20 | 0.305 | 220 | 11 |
| 25 | 0.271 | 225 | 9 |
| 30 | 0.241 | 230 | 7.7 |
| 35 | 0.220 | 235 | 6.7 |
| 40 | 0.201 | 240 | 6 |

(Contd.)...

| | | | |
|-----|-------|-----|------|
| 45 | 0.180 | 245 | 5.45 |
| 50 | 0.159 | 250 | 5 |
| 55 | 0.155 | 255 | 4.65 |
| 60 | 0.149 | 260 | 4.33 |
| 70 | 0.146 | 270 | 3.86 |
| 80 | 0.140 | 280 | 3.5 |
| 90 | 0.134 | 290 | 3.22 |
| 100 | 0.131 | 300 | 3.00 |
| 110 | 0.131 | 310 | 2.82 |
| 120 | 0.131 | 320 | 2.66 |

From the recovery plot, $\Delta s' = 0.41$ m per log-cycle of t/t' and

$$T = \frac{2.3 Q}{4\pi\Delta s'} = \frac{2.3(2.000/60)}{4\pi(0.41)} = \mathbf{0.0149 \text{ m}^2/\text{s}}$$

$$= 1.284 \times 10^6 \text{ lpd/m,}$$

and S can be obtained from $s_1 = 1.51$ m after 200 min of pumping as

$$s_1 = \frac{2.3Q}{4\pi T} \log \frac{2.25 T t_1}{r^2 S} \quad \log \frac{2.25 T t_1}{r^2 S} = \frac{4\pi (0.0149) 1.51}{2.3(2.000/60)} = 3.69$$

$$\text{Antilog of } 3.69 = 4898$$

$$\frac{2.25(0.0149) 200 \times 60}{20^2 S} = 4898$$

$$\therefore \mathbf{S = 0.000206}$$

Ground Water Extraction

Excessive lowering of the groundwater table by pumping may result in crop failures, depletion of a nearby stream by increased percolation losses, salt water intrusion in coastal aquifers, and occasionally serious settlement of the ground surface.

The natural recharging of ground water regimen can be supplemented by ponding or water spreading. For confined aquifers or shallow beds where ponding is not practicable, recharging is affected by pumping water down the wells at rates rather less than the corresponding withdrawal rates. Mostly recharge water is excess surface water, but industrial waste water, sewage and uncontaminated cooling water from industrial and airconditioning plants are used in some countries.

Sea water intrusion in coastal aquifers occurs when permeable formations out crop into a body of sea water and when there is landward gradient. Intrusion can be controlled by reducing pumping, by increasing supply or by constructing a physical barrier.

There is need for legislation of groundwater extraction and regulation to check indiscriminate draining of groundwater resources. Precautions should be taken against pollution of surface and subsoil waters by enacting legislation.

Tube well schemes may be integrated with the canal irrigation schemes by suitably spacing them along the drainage lines in the distribution area. The drainage system must be planned as an integral part of the distribution system in the design stage itself. The drainage

water may be used again by pumping in double and triple cropping as is already in practice in Krishna and Godavari deltas.

For a detailed study of ground water *i.e.*, Ground Water Survey, Geohydrology and Tube Wells, and Irrigation Systems, reference may be made for the Author's companion volume '**Ground Water – 3rd Edn.**' by the same Publisher.

Assignment Problems

- 1 A 300 mm production well tapping an artesian aquifer 30-m thick is continuously pumped at constant rate of 100 m³/hr for 1 day and the drawdowns in an observation well at 80 m from the pumped well are given below. Compute the coefficients of transmissibility, permeability, and storage of the aquifer. What is the drawdown in the pumping well after 180 days of continuous pumping assuming no recharge.

| <i>Time (min)</i> | <i>Drawdown (m)</i> | <i>Time (min)</i> | <i>Drawdown (m)</i> |
|-----------------------|-------------------------|-----------------------|-------------------------|
| 1 | 0.14 | 60 | 0.70 |
| 2 | 0.22 | 80 | 0.75 |
| 3 | 0.27 | 100 | 0.80 |
| 4 | 0.31 | 300 | 0.83 |
| 6 | 0.34 | 500 | 1.00 |
| 7 | 0.38 | 700 | 1.03 |
| 8 | 0.40 | 900 | 1.06 |
| 10 | 0.43 | 1000 | 1.08 |
| 30 | 0.60 | 1440 | 1.14 |

(1375 m²/d, 45.8 m/d, 1.35 × 10⁻⁴, ...)

- 2 A 400-mm-production well penetrating a water table aquifer is pumped at a constant rate of 100 m³/hr for a period of 200 days. The drawdowns in three observation wells are given below. Compute the coefficient of storage and transmissibility of the aquifer.

| | | | |
|--------------------------------|------|------|------|
| Observation Well | A | B | C |
| Distance from pumping well (m) | 2 | 20 | 200 |
| Drawdown (m) | 2.75 | 1.80 | 0.90 |

(977 m²/d, 0.11)

Appendix E

FLOOD ROUTING BY CHARACTERISTIC CONCEPTS

The hydrological methods of flood routing discussed in Chapter—9 were based on the continuity equation in a simplified finite form called the storage equation.

$$\bar{I} = \bar{O} + \frac{\Delta S}{\Delta t}$$

where \bar{I}, \bar{O} are the mean values of inflow and outflow, and ΔS is the increment in storage in period Δt .

Flows and elevations within a reservoir were not directly determined but estimated from flow profiles and rating curves.

A more mathematical method exists, based on the principle of continuity (law of conservation of mass) and energy principle (law of conservation of energy), which permit computation of stage or discharge hydrographs at any point in the stream, as well as the water surface profile at any time. The basic differential equations for gradually varied unsteady flow in open channels are

$$\text{Continuity eqn. :} \quad B \frac{\partial H}{\partial t} + \frac{\partial(AV)}{\partial x} = q \quad \dots(2)$$

$$\text{Energy eqn. :} \quad \frac{\partial V}{\partial t} + V \frac{\partial V}{\partial x} + \frac{V}{A} q = g \left(S_0 - S_f - \frac{\partial y}{\partial x} \right) \quad \dots(3)$$

where H = water surface elevation

x = distance along channel

B = width of channel at water surface

S_0 = bed-slope of channel

S_f = friction slope

t = time

y = depth of flow

V = velocity of flow

q = local inflow into channel per unit width

By selecting finite time and space differences and assuming boundary conditions, numerical solutions of the above basic differential equations can be made by the use of electronic

computers (since the computations are very laborious). The method of characteristics (Abbott, 1966) may be used, for example. This method of routing by characteristic concept is called *hydraulic routing*.

Using finite differences, the derivatives in the differential equations are replaced by difference quotients and the approximate solutions are obtained by solving linear equations for the desired quantities like water surface elevation, flow velocity, etc. Thus, for the series of net points shown in Fig. E-1 (a) and substituting in equation (2),

$$H_p = H_e + \frac{1}{B_e} \left[\frac{\Delta t}{\Delta x} (A_A V_A - A_B V_B) + \frac{2 \Delta t q}{B_c} \right] \quad \dots(4)$$

substituting in Eq. (3) and using Manning's formula to define S_f ,

$$V_p = V_c + \frac{\Delta t}{\Delta x} \left[\frac{V_A^2 - V_B^2}{2} + g(H_A - H_B) \right] - \left[\frac{2 \Delta t q_{AB} V_c}{A_c} + \frac{2 \Delta t g V_c |V_c|}{(R^{2/3}/n)^2} \right] \quad \dots(5)$$

where $|V_c|$ = velocity at C ignoring sign

n = Manning's roughness

R = hydraulic mean radius

Knowing the quantities at A, B and C, H_p and V_p (*i.e.*, water surface elevn. and flow velocity at P) can be determined for the interior point P, from Eqs. (4) and (5) by knowing values at $x - \Delta x$ and $x + \Delta x$, *i.e.*, towards left and right of the line x . For a point on the boundary such as a dam different equations must be used.

Applying finite differences to a series of net points shown in Fig. E-1 (b-i), for the right boundary where the discharge Q is prescribed

$$H_p = H_c + H_A - H_E + \frac{1}{B_D} \left[4 \Delta t q_D + \frac{\Delta t}{\Delta x} (A_E V_E + A_A V_A - Q_p - Q_c) \right] \quad \dots(6)$$

$$\text{Assuming } Q = AV \text{ at any point, } V_p = \frac{Q_p}{A_p} \quad \dots(6 a)$$

For the left boundary Fig. E-1 (b-ii) and prescribed discharge Q and following the same procedure

$$H_p = H_c + H_A - H_E + \frac{1}{B_D} \left[4 \Delta t q_D + \frac{\Delta t}{\Delta x} (A_E V_E + A_A V_A - Q_p - Q_c) \right] \quad \dots(7)$$

$$\text{and } V_p = \frac{Q_p}{A_p} \quad \dots(7 a)$$

At boundary points where the water surface elevation H is prescribed, two equations for V are needed, to compute V at each Δt intervals along the x -line, instead of at $2\Delta t$ intervals as can be seen in Fig. E-1 (a) and (b).

For the right-boundary condition shown in Fig. E-1 (c-i) where H is prescribed and which is an even-to-odd line, solution of Eq. (3) for V gives

$$V_p = V_c + \beta_c B_c (H_c - H_p) + \frac{1}{2} \left\{ \left[\frac{V_p^2 - V_c^2}{2} + g(H_A - H_c) \right] + \beta_c (Q_A - Q_c) \right\} \frac{\Delta t}{\Delta x} - \frac{2 \Delta t g V_c |V_c|}{(R^{2/3}/n)^2} + q_{AC} \left(B_c - \frac{V_c}{A_c} \right) \quad \dots(8)$$

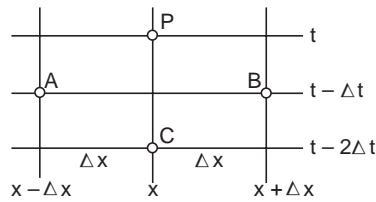

(a) Interior point P: Q-prescribed Eqs. (4) and (5) for H, V

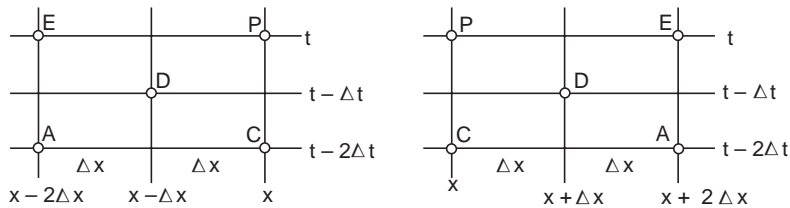

(i) Right boundary point P
Eqs. (6) and (6a) for H, V

(ii) Left boundary point P
Eqs. (7) and (7a) for H, V

(b) Boundary points : Q-prescribed

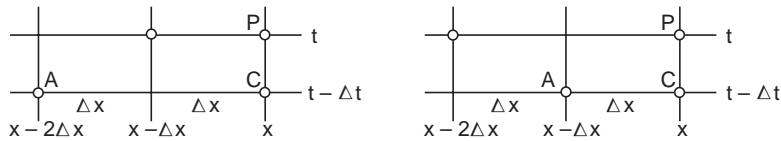

(i) Right boundary point P
even to odd line Eq. (8) for V

(ii) Right boundary point P
odd to even line Eq. (8a) for V

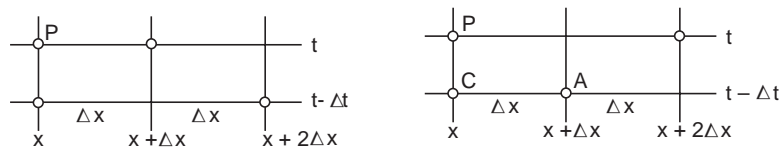

(iii) Left boundary point
even to odd line Eq. (8b) for V

(iv) Left boundary point P
odd to even line Eq. (8c) for V

(b) Boundary points : H-prescribed

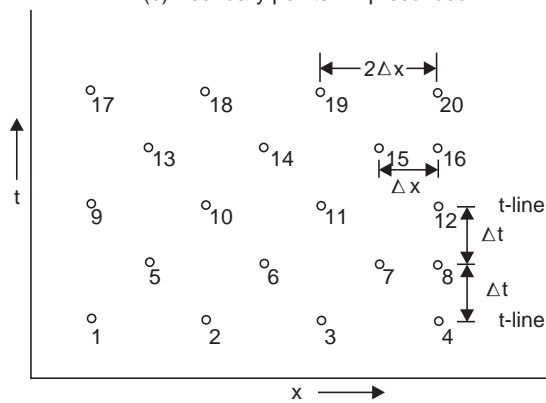

(d) The x-t plane

Fig. E-1 Net points in finite difference schemes

where
$$\beta_c = \sqrt{\frac{g}{A_c B_c}}$$

and for the right boundary odd-to-even line, with H prescribed, Fig. E-1 (c-ii), use Eq. (8)

$$\text{with } \frac{\Delta t}{\Delta x} \text{ replaced by } 2 \frac{\Delta t}{\Delta x} \quad \dots(8a)$$

At the left boundary even-to-odd line with H prescribed, Fig. E-1 (c-iii), use Eq. (8)

$$\text{with } \beta_c \text{ replaced by } -\beta_c \quad \text{and} \quad \frac{\Delta t}{\Delta x} \text{ by } -\frac{\Delta t}{\Delta x} \quad \dots(8b)$$

and for the left-boundary odd-to-even line, with H prescribed, Fig. E-1 (c-iv) use Eq. (8)

$$\text{with } \beta_c \text{ replaced by } -\beta_c \quad \text{and} \quad \frac{\Delta t}{\Delta x} \text{ replaced by } -2 \frac{\Delta t}{\Delta x} \quad \dots(8c)$$

Because of the characteristics of the two basic differential equations used to derive Eqs. (4) to (8c), a maximum permissible ratio for making the computations from time t to $t + \Delta t$, is given by the inequality

$$\frac{\Delta t}{\Delta x} \leq \frac{1}{V + c} \quad \dots(9)$$

where c is the celerity of small waves given by $c = \sqrt{gy_m}$,

where y_m = mean depth of the river. For example, if $y_m = 10$ m, $V = 1.6$ m/s, $c = \sqrt{9.81 \times 10} = 9.92$ m/s and $\frac{\Delta t}{\Delta x} < 0.087$ s/m.

Computational Procedure

Starting with nearly steady conditions, Q and H must be known (or assumed) for all net points along two consecutive t -lines, say point 1–8, in Fig. E-1 (d). Values of V ($= Q/A$) should be computed for the points 1-8.

Suppose for the right boundary H is prescribed, and for the left boundary Q is prescribed. Based on the values of points 2, 5 and 6, values of H and V at point 10 can be computed by Eqs. (4) and (5). Similarly, H and V at point 11 can be computed based on values at points 3, 6 and 7. This procedure can be continued for an indefinite number of interior points along the x -axis for a particular t -line.

At the left boundary where Q is prescribed using values at points 1, 2, 5 and 10, H at point 9 can be computed by Eq. (7) and $V = Q/A$.

At the right boundary where H is prescribed, using values at points 7 and 8, V at point 12 can be computed by using odd-to-even line Eq. (8a). By using values at points 11 and 12, V at point 16 can be computed by using even-to-odd line Eq. (8).

Following the above computational procedure, values of H and V at points on successive t -lines can be computed.

The product $\Delta x \cdot \Delta H$ gives changes in storage for the continuity equation. The Manning's roughness ' n ' can be determined from steady flow profiles. Local inflow can best be determined by stream gauges on tributaries, and from rainfall using unit hydrographs.

Despite the difficulties in the determination of the parameters like A , R , n , c , etc., the methods that have been developed from the characteristic concepts have shown increasing utility.

Appendix F

HYDROLOGIC EQUATION AND WATER BALANCE

The hydrologic equation is nearly a statement of the law of conservation of matter and is given by

$$\text{Inflow} = \text{Outflow} + \Delta \text{Storage}$$

i.e., during a given time the total inflow to a given area must equal the total outflow plus the charge in storage.

The items of inflow (into a basin or sub-basin) are :

- | | |
|-----------------------------------|---|
| (i) Precipitation (P) | (ii) Surface inflow (Q_i) |
| (iii) Subsurface inflow (G_i) | (iv) Imported water or sewage (piped or channeled into the basin) |

The items of outflow (from the basin or sub-basin) are:

- | | |
|-----------------------------------|---|
| (i) Surface outflow (Q_0) | (ii) Subsurface outflow (G_0) |
| (iii) Evaporation | (iv) Transpiration |
| (v) Evapo-transpiration (E_t) | (vi) Exported water or sewage (piped or channeled out of the basin) |

The items of storage are:

- (i) Change in ground-water storage (GWS)
- (ii) Change in soil-moisture storage (SMS)
- (iii) Snow cover (d_s)
- (iv) Surface storage (reservoir)
- (v) Depression storage (puddles or depressions)
- (vi) Detention storage (if not in channels)
- (vii) Channel storage (valley storage)

The water balance of a basin (or sub-basin) states that in a specified period of time all water entering a basin must be consumed, stored or go out as surface or subsurface flow. Water balance for a given basin should be worked out for a sufficiently long period so that the various items approach a steady state average conditions and allow direct determination of as many items in the equation as possible. For example, a study of the water balance of Ganga-

Ramganga Doab (area = 1.63 M.ha) in U.P. was conducted by A Satish Chandra and Saxena (1975) for the year 1971-72 and the results obtained are given below:

Inflow

| | M.ha-m |
|---|-------------|
| (i) Precipitation (P) | 1.77 |
| (ii) Surface and subsurface inflow ($Q_i + G_i$) | <u>0.09</u> |
| Total | 1.86 |

Outflow

| | |
|---------------------------------------|-------------|
| (i) Stream flow (Q_0) | 0.98 |
| (ii) Evapotranspiration (E_t) | 0.80 |
| (iii) Subsurface outflow (G_0) | negligible |
| (iv) Change of storage (ΔS) | 0.07 |
| (v) Other losses | <u>0.01</u> |
| Total | 1.86 |

Appendix G

DISTRIBUTION PERCENTAGES FOR DIFFERENT UNIT PERIODS

Example G-1 Rainfall occurs on a basin of 288 km^2 at a uniform rate of 25 mm/hr for 4 hours. The loss rate may be assumed at an average of 5 mm/hr . The mean values of the streamflow for the successive 4-hr periods are 414, 686, 458, and 238 cumec, respectively. A constant base flow of 50 cumec may be assumed. Determine the set of distribution percentages on the basis of a unit period of: (a) 4-hr, (b) 2-hr.

Solution (a) 4-hr distribution graph percentages (Bernard) : The mean D.S.R. for the successive 4-hr periods may be obtained by deducting the constant base flow of 50 cumec as 364, 636, 408 and 188 cumec.

The percentage which runs off

| | |
|----------------------------|--|
| during the 1st 4-hr period | $= \frac{364}{364 + 636 + 408 + 188} \times 100$ |
| | $= \frac{364}{1596} \times 100 = 22.8\%$ |
| for the 2nd 4-hr period | $= \frac{636}{1596} \times 100 = 39.9\%$ |
| for the 3rd 4-hr period | $= \frac{408}{1596} \times 100 = 25.6\%$ |
| for the 4th 4-hr period | $= \frac{188}{1596} \times 100 = 11.7\%$ |
| | Total 100.0 |

Thus, for a 4-hr distribution graph, the percentages are: 22.8, 39.9, 25.6, 11.7.

(b) 2-hr distribution graph percentages (*S*-curve technique):

First the *S*-hydrograph is derived by applying the 4-hr set of distribution percentages to a succession of 4-unit storms (to produce constant outflow) (Table G-1). The *S*-hydrograph is plotted with mean ordinates of 22.8, 62.7, 88.3, and 100.0 for the successive 4-unit periods (Fig. G-1). The mean ordinates of the *S*-hydrograph for the successive 2-hr periods are measured from the graph. The *S*-hydrograph is lagged by 2-hr (unit period of the required distribution graph). The mean difference between the two *S*-hydrographs for successive 2-hr periods gives the distribution percentages of the required 2-hr distribution graph as 10, 23, 21, 17, 13, 9, 5, 2. See also Example 5.6 and Table 5.7.

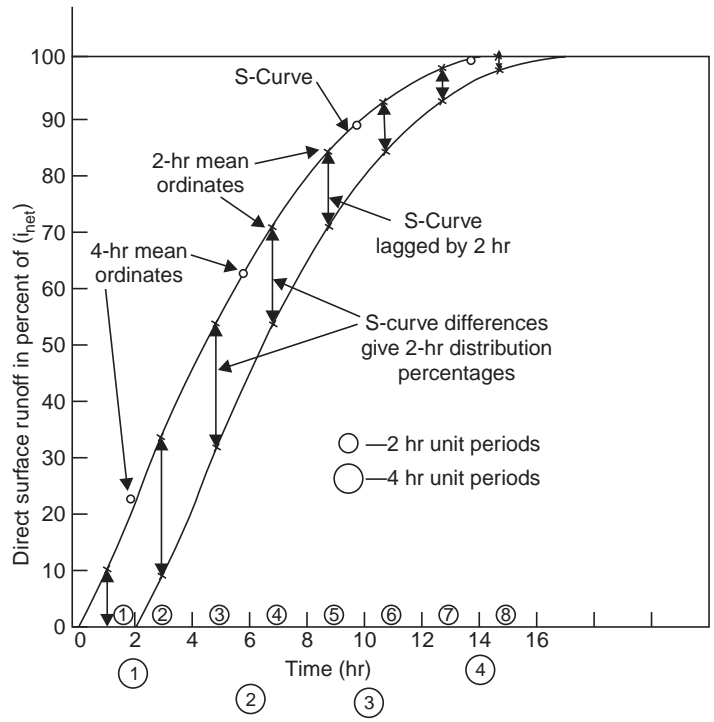

Fig. G-1 Derivation of 2-hr distribution percentages (Example G-1)

Appendix H

UNIT CONVERSION FACTORS

Length

$$1 \text{ in} = 2.54 \text{ cm}$$

$$1 \text{ ft} = 30.48 \text{ cm}$$

$$1 \text{ mi} = 1.609 \text{ km}$$

$$1 \text{ m} = 3.281 \text{ ft}$$

$$1 \text{ km} = 0.6214 \text{ mi}$$
$$= 0.54 \text{ nautical mile}$$

$$1 \text{ naut mile} = 1.852 \text{ km}$$

Volume

$$1 \text{ cft} = 28.32 \text{ lit}$$
$$= 0.02832 \text{ m}^3$$

$$= 6.24 \text{ imp. gal}$$

$$= 7.48 \text{ US gal}$$

$$1 \text{ imp. gal} = 1.2 \text{ US gal}$$
$$= 4.546 \text{ lit}$$

$$1 \text{ US gal} = 0.833 \text{ imp. gal}$$
$$= 3.79 \text{ lit}$$

$$1 \text{ m}^3 = 35.315 \text{ cft}$$
$$= 220 \text{ imp. gal}$$

$$= 264 \text{ U.S. gal}$$

$$= 1000 \text{ lit}$$

$$1 \text{ cc} = 0.061 \text{ in}^3$$

$$1 \text{ acre-ft (aft)} = 43560 \text{ cft}$$
$$= 1233.5 \text{ m}^3$$
$$= 2.71 \times 10^5 \text{ imp. gal}$$

$$1 \text{ km}^3 = 0.811 \text{ million aft (M. aft)}$$

$$1 \text{ ha-cm} = 100 \text{ m}^3$$

$$1 \text{ Mm}^3 = 810.7 \text{ aft}$$

$$1 \text{ aft} = 0.123 \text{ ha-m}$$

$$= 1230 \text{ m}^3$$

$$= 2.71 \times 10^5 \text{ imp. gal}$$

Area

$$1 \text{ in}^2 = 6.452 \text{ cm}^2$$

$$1 \text{ ft}^2 \text{ (sft)} = 0.0929 \text{ m}^2$$

$$1 \text{ cm}^2 = 0.155 \text{ in}^2$$

$$1 \text{ m}^2 = 10.76 \text{ ft}^2$$

$$1 \text{ acre} = 0.4047 \text{ ha}$$

$$= 4047 \text{ m}^2$$

$$= 43560 \text{ sft}$$

$$1 \text{ ha} = 10^4 \text{ m}^2$$

$$= 100 \text{ acres}$$

$$= 2.471 \text{ acres}$$

$$1 \text{ are} = 100 \text{ m}^2$$

$$1 \text{ km}^2 = 100 \text{ ha}$$

$$= 247 \text{ acres}$$

$$1 \text{ mi}^2 = 2.59 \text{ km}^2$$

$$= 640 \text{ acres}$$

Velocity

$$1 \text{ ft/sec (fps)} = 30.48 \text{ cm/s}$$

$$1 \text{ m/sec} = 3.281 \text{ fps}$$

$$1 \text{ mph} = 1.467 \text{ fps}$$

$$= 1.609 \text{ kmph}$$

= 0.8684 knot
 1 knot = 1.69 fps
 = 0.515 m/sec
 1 kmph = 0.2778 m/s
 = 0.9113 fps
 = 0.6214 mph
 1 m/day = 22.9 gpd/sft
Acceleration due to gravity (g)
 $g = 32.2 \text{ ft/s}^2$
 = 981 cm/s²
 = 9.81 m/s²
Flow rate (discharge)
 1 cfs (cusec) = 0.0283 cumec (m³/s)
 = 28.3 lps
 = 449 US gpm
 = 374.03 imp. gpm
 = 1.983 aft/day
 = 724 aft/year
 1 m³/sec = 35.31 cfs
 = 19.01 × 10⁶ imp. gpd
 = 13200 imp. gpm
 = 15800 US gpm
 = 70 aft/day
 1 m³/day = 2190 imp. gpd
 1 mgd (imp.) = 695 imp. gpm
 = 3160 lpm
 = 0.0527 m³/s
 1 aft/day = 188.57 imp. gpm
 = 271542 imp. gpd
 = 1233.5 m³/day
 1 US gpd = 4.38 × 10⁻⁸ m³/s
 1 US gpm = 6.31 × 10⁻⁵ m³/s
 1 imp. gpm = 7.57 × 10⁻⁵ m³/s
 1 cfs ≈ 1 acre-in/hr
Force
 1 kg_f = 9.81 N
 = 2.205 lb
Work or Energy
 1 m·kg_f = 9.81 N·m (Joule)

Power

1 m·kg_f/sec = 9.81 N·m/s (watt)
 1 metric hp = 736 watt
 = 0.736 kW

Dynamic viscosity

1 lb·sec/ft² = 478.8 poise (P)
 1 kg_f·sec/m² = 9.81 N s/m²
 = 98.1 poise
 1 N s/m² = 10 poise
 = 1000 centi-poise (cP)

Kinematic viscosity

1 ft²/sec = 0.093 m²/sec
 = 929 stoke (St)
 1 m²/sec = 10⁴ stoke
 = 10⁶ centi stoke (c St)

Permeability

1 cm/sec = 864 m/day
 1 lpd/m² = 1.16 × 10⁻⁶ cm/sec
 1 m/day = 1.16 × 10⁻³ cm/sec
 = 1000 lpd/m²
 = 20.44 gpd (imp.)/sft
 = 24.54 gpd (US)/sft

Water quality

1 grain/U.S. gal = 17.1 ppm
 1 ppm = 1 mg/l
 1 taf = 735 ppm
 1 me/l = 1 epm
 1 ppm = 1.56 μ mho/cm
 TDS in ppm = 0.64 EC in μ mho/cm

Temperature

$(^{\circ}\text{F} - 32) \frac{5}{9} = ^{\circ}\text{C}$
 460 + °F = °R
 273 + °C = °K

Transmissibility

1 m²/day = 67.05 imp. gpd/ft
 = 80.52 US gpd/ft
 = 0.056 US gpm/ft

Pressure

$$\begin{aligned}
 1 \text{ atm} &= 1 \text{ bar} \\
 &= 1 \text{ kg}_f/\text{cm}^2 \\
 &= 14.5 \text{ psi} \\
 &= 30 \text{ in of Hg} \\
 &= 76 \text{ cm of Hg} \\
 &= 34 \text{ ft of water} \\
 &= 10^5 \text{ Pa} \\
 1 \text{ Pa} &= 1 \text{ N/m}^2 \\
 1 \text{ bar} &= 10^5 \text{ N m}^2 \\
 &= 100 \text{ KN/m}^2 \\
 &= 10^5 \text{ pa} \\
 \text{milli} &= \frac{1}{1000}
 \end{aligned}$$

$$\text{micro} = 10^{-6}$$

$$\text{hecto} = 10^2$$

$$\text{kilo} = 10^3$$

$$\text{mega} = 10^6$$

$$1 \text{ million} = 10^6$$

$$1 \text{ lakh} = 10^5$$

$$1 \text{ micron } (\mu \text{ m}) = \frac{1}{1000} \text{ mm}$$

$$= \text{millionth of a meter}$$

$$\pi = 3.1416 \dots$$

$$e = 2.7183 \dots$$

$$\log_{10} e = 0.4343$$

$$\log_e 10 = 2.303$$

SELECTED REFERENCES

- 1 Buragohain, P.C., M.E. Dissertation, University of Roorkee, U.P., 1976.
- 2 Carter R.W. and Godfrey, R.G., Storage and Flood Routing, USGS Wat. Sup. Paper 1543-B, p. 93, 1960.
- 3 Chander S., et. al., An approach to Flood Stage Forecasting, Water for Human Needs, Proc. of the 2nd World Congr. on Wat. Res., Vol. V-Technology and Ecology, IWRA and CBIP, New Delhi, Dec. 12-16, 1975.
- 4 Clark C.O., Storage and the Unit Hydrograph. Trans. ASCE, Vol. 110, p. 1419, 1945.
- 5 Corps of Engineers. Flood Hydrograph Analysis and Computations. Manuals EM 1110-2-1405, August 1959.
- 6 Crawford N.H. and Linsley R.K., Digital Simulation in Hydrology: Stanford Watershed Model IV, Tech. Rept. 39, Dept. of Civil Engg., Stanford University, 1966.
- 7 Dooge J.C.I. A General Theory of Unit Hydrographs. Journ. of Geoph. Res., Vol. 64, No. 2, pp. 241-256, 1959.
- 8 Emir Zelenhasic Theoretical Probability Distributions for Flood peaks. Hydr. paper No. 42, Colorado State University, Fort Collins, Colorado, 1970.
- 9 Fiering, et al., Synthetic Stream flows. Wat. Res. Manograph No. 1 Am. Geophy. Un. 1971.
- 10 Eleming G., Deterministic Simulation in Hydrology. American Elsevier, New York. 1974.
- 11 Hurst H.E., Long-term Storage Capacity of Reservoirs, Trans. ASCE, Vol. 116, pp. 770-808, 1951.
- 12 Klemes V., The Hurst Phenomenon-a Puzzle ? Wat. Res. Research 10, pp. 675-689, 1974.
- 13 Longbein W.B., Annual Floods and Partial Duration Series. Trans. Am. Geoph. Un., Vol. 30, No. 6, pp. 879-886, Dec. 1949.
- 14 Linsley R. and Crawford N., Continuous Simulation Models in Urban Hydrology. Geoph. Research Letters, 1, 1, pp. 59-62, 1974.
- 15 Matalas N.C., Autocorrelation of Rainfall and Stream Flow Minimums, USGS Prof. Paper 434-B. 1963.
- 16 Matalas N.C., Assessment of Synthetic Hydrology. Wat. Res. Research Vol. 3, No. 4, pp. 937-945, 1967.
- 17 Mc Carthy G.T., The Unit Hydrograph and Flood Routing. Unpublished paper presented at the conference of the North Atlantic Division, Corps of Engineers, US Army, New London, Conn. June 24. 1938. Printed by US Engr. Office, Providence RI.
- 18 Nash J.E., Determining Runoff From Rainfall. Proc. Inst. of Civ. Engrs. Vol. 10, p. 163, 1958.
- 19 Nash J.E., Systematic Determination of Unit Hydrograph Parameters. Journ. Geoph. Res., Vol. 64, p. 111, 1959.
- 20 Nash J.E., A unit Hydrograph Study with particular Reference to British Catchments. Proc. Inst. of Civil Engrs. London, Vol. 17, pp. 249-282, 1960.

- 21 Nash J.E. and Sutcliffe J.V., River Flow Forecasting Through Conceptual Models Part I-A: Discussion of Principles, *Journ. of Hydr.* Vol. 10, pp. 317-329, 1970.
- 22 Rainbird A.F., Methods of Estimating Area Average Precipitation Reports on WMO/IHD Projects, Rept. No. 3, Secretariat of the WMO, Geneva, 1967.
- 23 Sharma H.D. et. al., Stochastic Modelling for Flood Flows. Water for Human Needs. Proc. of the 2nd World Congress on Wat. Res., Vol. V-Technology and Ecology. IWRA & CBIP, New Delhi, pp-51-60, Dec. 1975.
- 24 Sinha U.N., Flood Forecasting in India—A Mathematical Model. Math Modelling for Simul. and Soln. of Wat. Res. Probs., Proc. Symp. Bihar College of Engineering Patna, April 15-17, 1976.
- 25 Snyder F.F., Synthetic Unit Hydrographs. Trans. Am. Groph, Un., Part I, pp. 447-454, 1938.
- 26 Snyder W.M., Hydrograph Analysis by Method of Least Squares Proc. ASCE Vol. 81, Sep. 793, Sept. 1955.
- 27 Soil Conservation Service National Engineering Handbook, Section 4, Hydrology, 1971, 1972.
- 28 Statistical Methods in Hydrology. Proc. of Hydr. Symp., No. 5, Mc Gill University, Feb. 24-25, 1966.
- 29 Tiruvengadachari, S. et. al., Flood in Cauvery Basin. Magnitude and Frequency—Proc. of the National Symp. on Hydr., Nov. 13-15, 1975, University of Roorkee, U.P.
- 30 Todorovic P., On Some Problems Involving Random Number of Random variables. Annals of Mathematical Statistics, Vol. 41, No. 3, 1970.
- 31 Water For Human Needs Proc. of the 2nd World Congr. on Wat. Res., Vol. V-Technology and Ecology. IWRA and CBIP, New Delhi, Dec. 12-16, 1975.
- 32 A Uniform Technique for Determining Flood Flow Frequencies. Hydrol. Comm., Water Resourc. Counc. Washigton, Bull 15, Dec. 1967.
- 33 Chow, V.T., A General Formula for Hydrologic Frequency Analysis, Trans. Am. Geophys. Union, Vol. 32, pp. 231-237, April 1951.
- 34 Foster H.A., Theoretical Frequency Curves and their Application to Engineering Problems. Trans. ASCE, Vol. 87, pp. 142-173, 1924.
- 35 Fuller W.E., Flood Flows. Trans ASCE, Vol. 77, pp. 564–617, 1914 and discussions by Allen Hazen, pp. 628.
- 36 Kohler M.A., and Linsley R.K., Predicting the Runoff from Storm Rainfall, U.S. Weather Bur. Res. Pap. 34, 1951.
- 37 Pearson K., Tables for Statisticians and Biometricians 3rd ed; Cambridge University Press, London 1930.
- 38 Pillai N.N., Journal of Irrigation and Power, pp. 241–248 April 1964, New Delhi.
- 39 Subrahmanyam V.P., Kama Raju M.V. and Ali M.M., Hydrometeorology and Water Balance of Krishna River Basin. Journal of the Inst. of Engrs. (India), Civil Engg. Divn., Vol. 61, Pt. CI 3, Nov. 1980, pp. 146-150.
- 40 Thomas H.A. and Fiering M.B., The Nature of the Storage Yield Function in 'Operations Research in Water Quality Management', Harvard University Water Program, 1963.
- 41 Dalrymple T. Regional Flood Frequency, High Res. Board Res. Rep. 11–B. pp. 4-20, 1950. The USGS has summarised flood data and presented regional frequency methods for the US in Wat. Sup. Pap. 1971–1989, 1994.
- 42 Kimball B.F., On Choise of Plotting Positions on Probability Paper. Jour. Amer. Stats. Assoc., 1960, 55, 291, 546-560.

- 43 Izzard C.F., Hydraulics of Runoff from Developed Surfaces, Proc. Highway Res. Board, Vol. 26, pp. 129–150, 1946.
- 44 Abbott, M.B., An Introduction to the Method of Characteristics, Thames and Hudson, London 1966.
- 45 Satish Chandra and R.S. Saksena, Water Balance Study of a Doab in U.P. (India), Second World Congress on Water Resources, New Delhi, 1975.
- 46 Rakesh Kumar et. al., Development of REgional Flood Formulae using L-moments for Gauged and Ungauged Catchments of North Brahmaputra River System, Journ. Inst. of Engrs. (India), vol. 84, May 2003, pp. 57-63.
- 47 Nash J.E., The form of instantaneous unit hydrograph, Int. Assn. of Sci and Hydrol, pub. vol. 45, no. 3, 1957, pp. 114-121.

BIBLIOGRAPHY

- 1 Butler S.S., Engineering Hydrology. Prentice-Hall, Inc; Englewood Cliffs, N.J., 1959.
- 2 Dandekar M.M. and Sharma K.N., Water Power Engineering. Vikas Publishing House Pvt. Ltd; New Delhi, 1979.
- 3 Davis C.V. and Sorensen K.E., Hand Book of Applied Hydraulics. McGraw-Hill Book Company, New York, 1969.
- 4 Desmukh. M. M., Water Power Engineering. Dhanpat Rai & Sons, Nai Sarak, Delhi, 1978.
- 5 Flood Control and The Use of Water Resources with special reference to Western India. Proc. of the Seminar organised by the south Gujarat University, Surat, Jan. 1969. Ed. R.N. Shelat, Dept. of Civil Engg; S.V. Regional College of Engg. and Tech; Surat. W. India.
- 6 Linsley K., Kohler A. and Paulhus L.H., Hydrology for Engineers. McGraw-Hill Book Company Inc. New York 1975.
- 7 Linsley K., Kohler A., and Paulhus L.H. Applied Hydrology. McGraw-Hill Book Company, Inc. New York, 1949.
- 8 Linsley and Franzini., Water Resources Engineering. McGraw-Hill Book Company, New York, 1979, 3 Ed.
- 9 Nemece, J. Engineering Hydrology. McGraw-Hill Book Company, New York, 1972.
- 10 Varshney R. S., Concrte Dams. Oxford and IBH Publishing Company, New Delhi, 1978.
- 11 Ven Te Chow, Ed. Hand Book of Applied Hydrology. McGraw-Hill Book Company, New York, 1964.
- 12 Wilson E.M., Engineering Hydrology. ELBS and Macmillan, London, 1980.
- 13 Wisler C.O. and Brater E.F., Hydrology. John Wiley & Sons, Inc. New York, 1959.
- 14 Ciriani T.A. et. al., Mathematical Models for Surface Water Hydrology. John Wiley & Sons, New York, 1977.
- 15 Hammer and Mac Kichan. Hydrology and Quality of Water Resources. John Wiley & Sons, New York, 1981.
- 16 Mathematical Modelling for Simulation and Solution of Water Resources Problems. Proc. All India Symp., April 15–17, 1976, Bihar College of Engineering, Patna.
- 17 Varshney R.S., Engineering Hydrology. Nem Chand & Bros., Roorkee, U.P., 1979, 2nd Ed.
- 18 Warren Viessmann. et. al. Introduction to Hydrology. IEP: A Dun-Donnelley Publisher, New York. Copyright by Thomas Y. Crowell Company, Inc., 1977, 2nd Ed.; 3rd Edn. in 1989, Harper & Roe Publishers, Singapore, Rs. 350.
- 19 Allen J. Hjelmfelt, JR. & John J., Cassidy, Hydrology for Engineers and Planners, Iowa State University Press/AMES, Iowa, 1975.
- 20 Mutreja, K.N., Applied Hydrology, Tata McGraw-Hill Pubishing Co., Lte., New Delhi-110002, 1986, Rs. 236. [NBT Rs. 87]
- 21 Reginald W. Herschy, Streamflow Measurement, Elsevier Applied Science Publishers, Ltd., London & New York, 1985.

INDEX

- a.a.r.*, 4, 23, 24
- API, 320
- Aquiclude, 192
- Aquifer, 192
 - confined, 197
 - specific yield, 192
 - storage coefficient, 194
 - types, 192
 - unconfined (water table), 196
- Aquiclude, 192
- Aquifuge, 192
- Aquitard, 192
- Area-velocity method, 172, 176, 179
- Arid climate, 23
 - regions, 306
- Artesian well, 193

- Bank storage, 97, 123, 124
- Base flow, 97, 123, 124
- Basin, 6, 97
 - characteristics, 97
 - compactness coefficient, 99
 - form factor, 99
 - lag, 127, 155
 - mean and median elevation, 101
 - shape—fan, fern, 99
 - slope, 98, 100
 - Snyder's, 151, 155
 - Tapthi, 5, 6
- Bernards distribution graph, 142, 144, 447
- Blaney-Criddle method, 68

- California method, 38
- Catchment characteristics, 97
 - circulating ratio, 101
 - compactness coefficient, 101
 - drainage density, 98
 - elongation ratio, 9, 101
 - fan-shaped, 99
 - fern-shaped, 99
 - form factor, 99
 - Horton's grid, 100
 - isochrones, 104, 109
 - maximum rate of runoff, 111
(flood-rational formula)
 - mean and median elevation, 101
 - runoff, 106
 - from time of concentration, 108
 - slope, 98
 - Snyder's, 151
 - stream density, 98
 - yield, 108, 109, 111
- Causserina trees, 65
- Cavity wells, 200
 - yield of, 200
- Cetyl alcohol, 65
- Check dams, 246
- Channel improvement, 241, 244
- Clark's model, 149, 355, 397, 400
- Climate—arid, semi-arid, humid, 23, 306
- Cloud seeding, 403
 - technique, 404
 - operation, 406
 - case history (2005), 406
- Coaxial correlation (API), 322
- Coefficient of flood, 223, 225, 229
 - of skew, 228, 330
 - of variation, 228, 329, 330, 332
- Correlation coefficient, 317, 318, 324
 - multiple, 322
- Current meter gaugings, 174, 178
 - mean-section method, 177
 - mid-section method, 177

- Current meter rating, 174
Cyclonic storm, 23
- Darcy's law, 195
 validity of, 196
- Density current (reservoirs), 299
- Depression storage, 97
- Depth-area-duration (DAD) Curves, 11, 33, 35, 36
- Design flood, 238
 storm, 49, 217
- Detention storage, 97
- Detention storage, 97
- Distribution percentages, 128
 to composite runoff, 144-149, 160
 computation of stream flow from, 161
- Double mass analysis, 24
- Drainage divide, 98
 density, 98
- Drainage net, characteristics of, 98
- Drought-duration studies, 287, 332
- Dug-cum-borewell, 206
- Dupuit's equation, 196
 assumptions of, 198
- Effluent stream, 103
- Ephemeral stream, 103
- Encounter probability, 225, 235
- Evaporation (lake), 60
 Dalton's law, 61
 estimation, methods of, 62
 Blaney-Criddle, 68
 Index method, 69
 measures to reduce, 64
 pans, 62
 IMD Land pan, 62
 pan coefficient, 63
 piche evaporimeter, 63, 64
 soil (from), 66
- Evapotranspiration, 67
 estimation of, 68
 factors affecting, 70
- Extremal distribution, 333
(EV—I, II, III)
- f_{ave} -index, 82
- Field irrigation requirement (FIR), 69
- Floats, 173
- Floods, 212
 design flood, 216, 238
 empirical formulae, 213
 envelope curves, 214
 maximum probable (MPF), 10, 212, 218, 221, 430
 peak, estimation of, 213
 standard project (SPF), 10, 212, 218, 430
- Flood absorption capacity (FAC), 430, 431
- Flood control economics, 247, 252
 project, 253
- Flood control methods, 238
 Channel improvement, 241, 244
 Cutoff, 244
 Combination of, 249
 deepening, 244
 economics, 247
 levees, 241
 reservoirs, 239
 retarding basins, 240
 soil conservation measures, 245
- Flood forecasting, 251, 386
 by mathematical model, 389
 of R. Tapthi, 253
 warning system, 253
- Flood, maximum, estimation of 213
 Creager's formula, 214, 231
 Empirical formulae, 213
 rational formula, 231
 world enveloping formula, 231
- Flood frequency, 221
 Allen hazen, 38, 222
 annual floods (series), 222
 California, 38, 222
 curves, 341, 358
 encounter probability, 225, 235
- Foster's, 229
- Fuller, 214, 230, 337
 Gumbel, 222, 227, 236, 337
 Log-Pearson Type-III, 360, 361
 partial duration series (PDS), 228, 232
 Powell, 341
 regional, 361

- Stochastic method—
 - annual, 344
 - PDS, 344, 355
 - Ven Te Chow, 341
 - Weibull, 222, 230, 235, 236
- Flood hydrograph
 - of R. Tapthi, 12
 - due to multiple storms, 118, 159
- Flow-duration curves, 285
- Gamma distribution, 333
- Ground water flow, 195
 - radial flow into well (unsteady), 432
 - Jacob's method, 433, 433, 435, 437, 438
 - Dupuit's equation (steady), 196
 - Theis method, 432, 433
 - Theis recovery, 435, 436, 438
 - Reynold's number, for, 196
- Gumbel distribution (EV-I), 222, 227, 236, 334, 337
- Gumbel's probability data, 224
 - paper, 224, 228
- Gumbel's method, 222, 227, 236, 337
- Hazen's method, 38, 222
- Horton's constant, 70, 78
 - determination of, 75, 76
 - curve (infiltration), 71, 72, 74, 79
 - equation, 70, 77, 79
 - grid, 100
 - method, 75
- Hydraulic design, 112
- Hydrologic design, 112
- Hydrograph, 117
 - components, 117
 - distribution percentages, 142, 144, 447
 - flood (R. Tapthi), 12
 - due to multiple storms, 118, 159
 - separation, 122, 125
 - use, 422
- Hydrologic cycle, 11, 12
 - data, 14
 - study of Tapti basic, 5-12, 36
 - of R. Narmada, 9, 36, 364 (Pb. 6)
- Hydrology, 1, 11
 - scope of, 14
- Hydrometeorology, 70
- Hydrometeorological setup, 70
- Hyetograph, 37, 45, 85, 117
- Hypsometric curve, 101
- Humid climate, 23, 306
 - region, 309
- IMD land pan, 62
- Index of wetness, 23
- Indian Meteorological Department (IMD), 22
- Infiltration, 70
 - constants, 70, 76, 79
 - cumulative, 80
 - curve, 71, 72, 74
 - indices, 61
 - f_{ave} -index, 82
 - ϕ -index, 82, 83
 - W-index, 82
 - loss, 82
 - losses, supra rain technique, 83
 - rate(f), 81
 - determination, methods of, 71
- Infiltrometer, double ring, 71, 77
 - tube, 73
- Influent stream, 103
- Inflection point, 117, 123, 127, 375, 376
- Intensity-duration curves, 46
- Intensity-duration-frequency (IDF)
 - of storms, 38, 41, 114
- Intensity of design storm, 114, 215, 216
- Interception loss, 61, 74
- Interflow, 96
- Instantaneous unit hydrograph (IUH), 149, 378, 393
 - determination, methods of, 371, 393
 - Clarks model method, 397, 398, 400, 401
 - storage coefficient (K), 375, 399
 - conceptual models, 373
 - convolution integral, 372
 - isochrones (TAD), 377, 400
 - Nash model, 394
 - S-curve, 371, 393
- Jacob's method, 433-437
- Kimball's method (Weibull), 38

- Lag time, 127, 155
- Lake evaporation, 64
estimation, methods of, 62
measures to reduce, 64
monthly data, 61
- Land pan, 62
- Levees, 241, 249
- Linear regression, 315, 317, 319, 324
multiple, 319, 322
Load curve (power), 291
Load factor, 292
Lognormal distribution, 333
Log-Pearson distribution, 358, 361
- Mass curve, of rainfall, 21, 37, 45
of reservoir, 280, 282, 284, 381
- Mathematical models, 366
deterministic, 366
empirical, 366
rainfall-runoff, 368, 370
stochastic, 366
watershed, 370
- Maximum probable flood (MPF), 10, 212, 218, 221
estimation, methods of, 213
enveloping curves, 215
of R. Tapthi, 217, 221
hydrograph of R. Tapthi, 221
- Mean, median and mode (statistics), 327, 328, 331
- Moisture adjustment factor (MAF), 10, 217
- Multipurpose reservoirs, 424
- Muskingum method, 270, 275
- Nash model, 394
- Normal distribution, 332
- Open (dug) wells, construction of, 206
hydraulics, 202
recuperation test, 203
specific yield, 203
yield tests, 202
- Overland flow, 13, 96
effect of wind, 420
hydrograph (Izzard), 112, 416, 420
laminar, 112, 413
turbulent, 416
- Pan coefficient, 63
- Partial duration, curves, 233, 344, 360
series (PDS), 282, 232, 234, 355
- Pearson's distribution (Type-III), 334
logarithmic, 335, 358
- Phytometer, 67
- Piche evaporimeter, 63, 64
- Piezometric surface, 193
- Plant load factor, 292
- Pondage, 288, 290
factor, 288
- Porosity, 193
- Poisson distribution, 333
- Power duration curve, 286, 287
- Power output, 283, 289
- PMP, 48, 212
- Precipitation, 17
adjustment of records, 23
convectonal, 17
cyclonic, 17
depth-area-duration curves, 11, 33, 35, 36
depth-duration curves, 11, 46
forms of, 13
frontal, 18
intensity duration curves, 38, 42, 46
length of record, 22
mass curve, 45
measurement of, 18
mean and median, 43
mean areal depth, 26
missing data, 23
orographic, 17
probable maximum (PMP), 49, 212
probability of occurrence, 38, 39, 47
non-occurrence, 39
types of, 17
- Radars, 22
- Rainfall, *a.a.r.*, 23, 24
frequency curve, 48
mass curve, 21, 37, 45
mean areal depth, 28
moving averages, 48
points, 27

- Rainfall data, analysis of, 38
 double mass, 24, 26
- Rainfall records, adjustment of, 23
 correlation, 38
 departments, 22
 length of, 22
 missing data, 23
- Rainfall-runoff model, 368, 370
 Correlation, 107, 317, 320
- Raingauge, automatic (recording), 19
 density, 22
 float type, 20
 optimum network, 31, 32
 radio reporting, 21
 recording, 19
 saturated network, 31
 Symon's (non-recording), 18
 tipping bucket, 19, 20
 weighing type, 19, 20
- Range (statistical), 327, 383, 385
- Rational formula (flood), 111, 114, 215, 231
- Rational method for yield, 108, 111
- Recurrence interval (return period), 38, 42, 48, 214, 215, 222, 224, 228, 231, 233, 337, 339, 343, 358, 360, 361
- Recession constant, 118
 time, 127
- Recession curve, 118, 399
- Reservoir, capacity curve, 425
 dead storage, 426, 429
 design studies, 428
 flood absorbing capacity (FAC), 430, 431
 live storage, 426
 mass curve, 280, 282, 284, 381, 423, 427, 428
 multipurpose, 425
 reduction in capacity, 300
 routing (flood), 263, 269
 sedimentation, 298, 300
 control, 303
 storage capacity, 281, 383, 425, 428
 trap efficiency, 301-303
 useful life, 302
- Residual mass curve, 383, 385
- Retarding basins, 240
- Rivers, of India, 3
 perennial, 4
- River basins, of India, 4
- River stage recorder (AWLR), 180
- Runoff, 77, 82, 83, 96
 coefficient, 108
 factors affecting, 104
 peak rate, 43, 114
- Runoff estimation, 106
 time of concentration method, 109
 empirical formulae, 106, 107
 infiltration method, 73, 77, 108
 overland flow method, 112, 413, 416
 rational method, 108, 111
 unit hydrograph method, 113
- Runoff river plant, 289
- Saltation, reservoirs, 298, 299
- Satellite photo, 23
- Sedimentation, of reservoir, 298, 300
 control, 303
- Sediment movement, reservoirs, 298
- Semi-arid climate, 23, 306
 regions, 307
- Sequent peak algorithm, 383, 386
- Soil conservation measures, 245
 Check dams, 246
 Contour farming, 247
 Contour trenching, 247
- Soil evaporation, 66
- Snow, sp. gr., density, 410
- Snow line, 411
 degree-day factor, 409
- Snow melt, 49
 physics of, 407
- Snow pack, 49, 411
- Snow surveying, 409
- Specific capacity, tube well, 199
- Specific yield, aquifer, 192, 194
 open (dug) well, 203
- Spillway, crest level, fixing of, 424
 length, 430
- Spillway design flood, 424
- Standard deviation, 328, 330
- Standard error of estimate, 304, 319, 386
- Standard project flood, 10, 212, 218, 430

- Stage-discharge rating curve, 176, 178, 184
 adjustment of, 181
 extension of, 181
- Statistics, elements, 327
 mean, median, 43, 44, 327, 328, 331
 mode, 328, 331
 skew distribution, 328
 skewness, 329
 coefficient of, 330
 variance, 329
- Station-year method, 24
- Storage capacity, reservoir, 281, 383, 488
- Storage coefficient, aquifer, 194
 basin, 375, 399
- Storm characteristics, correlation of,
 depth-duration, 11, 45
 intensity-duration, 46
 intensity-duration-frequency (IDF), 38, 41, 114
 design, 49, 217
 track, 9
 maximum probable (MPS), 10
- Storm maximisation, 10
 by moisture charge, 10, 217
 by unit hydrograph method, 221
- Streams, classification of, 103
 effluent, 103
 ephemeral, 103
 influent, 103
 intermittent, 104
 perennial, 104
- Stream flow components, 96
 separation of, 120
- Stream flow computation, 171, 185
 contracted area method, 172, 186
 salt concentration method, 172
 slope-area method, 171, 187
- Stream gauging, methods of 171
 area-velocity method, 172, 176, 179
 by current meter, 174, 176
 selection of site, 183
- Supra-rain technique, 83
 curve, 85
 Synthetic stream flow, 379
 Synthetic unit hydrograph, Snyder's, 149
- Tank irrigation, 109
 length of weir, 111
 yield for, 109
- Tapti basin, 6
 hydrological study, 5-12, 36
- Thiessen polygon method, 27, 28
- Time-area diagram (TAD), 378, 398, 400
- Time of concentration, 109, 398
 runoff from, 109, 398
- Transpiration, 67
 ratio, 67
- Transmissibility, 196, 199
- Trap efficiency, 301-303
- Unit hydrograph, 113, 124, 379
 application of, 157, 158, 160
 alteration of duration, 136
 assumptions of, 113
 average, 136
 derivation of, 124, 129
 from complex storms, 130, 132
 dimensionless, 156
 elements of, 126
 instantaneous (IUH), 149, 379, 393, 401
 limitations of, 127
 matrix method, 135
 propositions of, 127
 runoff estimation from, 113
 SCS method, 157
 synthetic (SUH), Snyder's 149
 transposing of, 154
- Unit storm, 127
- Unsaturated flow, 66
- Valley storage, 97, 106
- Variance, 327
- Velocity measurements, 172
- Velocity rods, 172
- Water balance, 87, 445
 of Krishna river basin, 87
- Water bearing formations, 192
- Water losses, 60
- Watershed leakage, 87

-
- Water resources, World's, 1
 - of India, 1
 - Well hydraulics, 196
 - Cavity wells, 200
 - Dupuit's equations, 196-198
 - Jacob's equations, 433-438
 - Open (dug) wells, 202
 - Thies equations, 432-438
 - Well interference, 207
 - Wells spacing, 207
 - W-index, 82
 - Yield (see runoff estimation), 106, 429
 - for tank, 109
 - rational method for, 106, 108